

PROFESSIONAL JAVASCRIPT® FOR WEB DEVELOPERS

FOREWORD.....	xlvi
INTRODUCTION	xlix
CHAPTER 1 What Is JavaScript?	1
CHAPTER 2 JavaScript in HTML	13
CHAPTER 3 Language Basics.....	25
CHAPTER 4 Variables, Scope, and Memory	101
CHAPTER 5 Basic Reference Types	125
CHAPTER 6 Collection Reference Types.....	167
CHAPTER 7 Iterators and Generators.....	225
CHAPTER 8 Objects, Classes, and Object-Oriented Programming	251
CHAPTER 9 Proxies and Reflect	323
CHAPTER 10 Functions	349
CHAPTER 11 Promises and Async Functions	391
CHAPTER 12 The Browser Object Model.....	437
CHAPTER 13 Client Detection.....	465
CHAPTER 14 The Document Object Model	491
CHAPTER 15 DOM Extensions	543
CHAPTER 16 DOM Levels 2 and 3.....	563
CHAPTER 17 Events.....	601
CHAPTER 18 Animation and Graphics with Canvas	671
CHAPTER 19 Scripting Forms	707
CHAPTER 20 JavaScript APIs.....	743
CHAPTER 21 Error Handling and Debugging.....	823
CHAPTER 22 XML in JavaScript.....	849
CHAPTER 23 JSON	861
CHAPTER 24 Network Requests and Remote Resources	871

Continues

CHAPTER 25	Client-Side Storage	919
CHAPTER 26	Modules	945
CHAPTER 27	Workers	969
CHAPTER 28	Best Practices	1035
APPENDIX A	ES2018 and ES2019	1067
APPENDIX B	Strict Mode	1087
APPENDIX C	JavaScript Libraries and Frameworks	1095
APPENDIX D	JavaScript Tools	1101
INDEX		1113

PROFESSIONAL

JavaScript[®] for Web Developers

PROFESSIONAL

JavaScript® for Web Developers

Matt Frisbie



Professional Javascript® for Web Developers

Published by
John Wiley & Sons, Inc.
10475 Crosspoint Boulevard
Indianapolis, IN 46256
www.wiley.com

Copyright © 2020 by John Wiley & Sons, Inc., Indianapolis, Indiana

Published simultaneously in Canada

ISBN: 978-1-119-36644-7
ISBN: 978-1-119-36635-5 (ebk)
ISBN: 978-1-119-36657-7 (ebk)

Manufactured in the United States of America

10 9 8 7 6 5 4 3 2 1

No part of this publication may be reproduced, stored in a retrieval system or transmitted in any form or by any means, electronic, mechanical, photocopying, recording, scanning or otherwise, except as permitted under Sections 107 or 108 of the 1976 United States Copyright Act, without either the prior written permission of the Publisher, or authorization through payment of the appropriate per-copy fee to the Copyright Clearance Center, 222 Rosewood Drive, Danvers, MA 01923, (978) 750-8400, fax (978) 646-8600. Requests to the Publisher for permission should be addressed to the Permissions Department, John Wiley & Sons, Inc., 111 River Street, Hoboken, NJ 07030, (201) 748-6011, fax (201) 748-6008, or online at <http://www.wiley.com/go/permissions>.

Limit of Liability/Disclaimer of Warranty: The publisher and the author make no representations or warranties with respect to the accuracy or completeness of the contents of this work and specifically disclaim all warranties, including without limitation warranties of fitness for a particular purpose. No warranty may be created or extended by sales or promotional materials. The advice and strategies contained herein may not be suitable for every situation. This work is sold with the understanding that the publisher is not engaged in rendering legal, accounting, or other professional services. If professional assistance is required, the services of a competent professional person should be sought. Neither the publisher nor the author shall be liable for damages arising herefrom. The fact that an organization or Web site is referred to in this work as a citation and/or a potential source of further information does not mean that the author or the publisher endorses the information the organization or Web site may provide or recommendations it may make. Further, readers should be aware that Internet Web sites listed in this work may have changed or disappeared between when this work was written and when it is read.

For general information on our other products and services please contact our Customer Care Department within the United States at (877) 762-2974, outside the United States at (317) 572-3993 or fax (317) 572-4002.

Wiley publishes in a variety of print and electronic formats and by print-on-demand. Some material included with standard print versions of this book may not be included in e-books or in print-on-demand. If this book refers to media such as a CD or DVD that is not included in the version you purchased, you may download this material at <http://booksupport.wiley.com>. For more information about Wiley products, visit www.wiley.com.

Library of Congress Control Number: 2018956541

Trademarks: Wiley, the Wiley logo, Wrox, the Wrox logo, Programmer to Programmer, and related trade dress are trademarks or registered trademarks of John Wiley & Sons, Inc. and/or its affiliates, in the United States and other countries, and may not be used without written permission. JavaScript is a registered trademark of Oracle America, Inc. All other trademarks are the property of their respective owners. John Wiley & Sons, Inc., is not associated with any product or vendor mentioned in this book.

*To Jordan, for her unwavering support no matter
how many times she heard “it’s almost done.”*

ABOUT THE AUTHOR

MATT FRISBIE has worked in web development for over a decade. During that time, he's been a startup co-founder, an engineer at a Big Four tech company, and the first engineer at a Y Combinator startup that would eventually become a billion-dollar business. As a Google software engineer, Matt worked on both the AdSense and Accelerated Mobile Pages (AMP) platforms; his code contributions run on most of the planet's web browsing devices. Prior to this, Matt was the first engineer at DoorDash, where he laid the foundation for their driver scheduling, menu management, and order dispatch infrastructure. Matt has written two books and recorded two video series for O'Reilly and Packt, speaks at frontend meetups and webcasts, and is a Level 1 sommelier. He majored in computer engineering at the University of Illinois at Urbana–Champaign. Matt's Twitter handle is @mattfriz.

ABOUT THE TECHNICAL EDITORS

CHAIM KRAUSE is a lover of computers, electronics, animals, and electronic music. He's tickled pink when he can combine two or more of these interests in one project. The vast majority of his knowledge is through self-learning. He jokes with everyone that the only difference between what he does at home and what he does at work is the logon he uses. As a lifelong learner, he is often frustrated with technical errors in documentation that waste valuable time and cause unnecessary frustration. One of the reasons he works as a technical editor on technology books is to help others avoid those same pitfalls.

MARCIA WILBUR is a technical communicator, consulting in the semiconductor field, focusing on Industrial IoT (IIoT) and AI. Marcia holds degrees in computer science, technical communication, and information technology. As Copper Linux User Group president, she is heavily involved with the maker community, leading West Side Linux + Pi, and the East Valley, leading regular Raspberry Pi, Beaglebone, Banana Pi/Pro, and ESP8266 projects. These projects include home automation, gaming consoles, surveillance, network, multimedia, and other "pi fun."

In addition to tinkering, she volunteers for different organizations using Pi units and Linux to provide access to educational content for K–12 schools in rural, underserved, and disaster-stricken areas. For fun, she serves the community as the lead Debian developer for Linux Respin, a backup and distro customization tool.

ACKNOWLEDGMENTS

THANKS TO WILEY FOR allowing me to take on this project. Writing the fourth edition of *Professional JavaScript for Web Developers* has been one of the most profoundly challenging yet rewarding projects I've ever worked on, and the patience and support at Wiley was fundamental to getting the book out the door. Thanks to the Wiley staff, specifically Jim Minatel, who put this project in my hands and saw it through.

I'd like to acknowledge Nicholas C. Zakas, the author of the first three editions, for all the work he put in before I became involved. The book would not have amounted to much without the ironclad foundation he laid. I wish him a continued and speedy recovery.

Special thanks to Adaobi Obi Tulton for her guidance. She was an invaluable resource throughout the entire process, and I could not have done it without her patience and expertise.

I'd also like to thank everyone who provided feedback on the book's drafts: Samuel Kallner, Chaim Krause, Marcia Wilbur, Nancy Rapoport, Athiyappan Lalith Kumar, and Evelyn Wellborn. A book like this would fall apart without your contributions.

Finally, I'd like to thank Zach Tratar for writing the foreword. I was fortunate enough to meet Zach the same day I moved to San Francisco. In the years since, he has proven himself to be a feverishly erudite and eminently likeable fellow—not to mention an uncommonly good software engineer. I am honored that he agreed to contribute to this book.

CONTENTS

<i>FOREWORD</i>	<i>xlvii</i>
<i>INTRODUCTION</i>	<i>xlix</i>
CHAPTER 1: WHAT IS JAVASCRIPT?	1
A Short History	2
JavaScript Implementations	3
ECMAScript	3
ECMAScript Editions	4
What Does ECMAScript Conformance Mean?	5
ECMAScript Support in Web Browsers	5
The Document Object Model	7
Why the DOM Is Necessary	8
DOM Levels	8
Other DOMs	9
DOM Support in Web Browsers	9
The Browser Object Model	10
JavaScript Versions	11
Summary	12
CHAPTER 2: JAVASCRIPT IN HTML	13
The <script> Element	13
Tag Placement	16
Deferred Scripts	17
Asynchronous Scripts	17
Dynamic Script Loading	18
Changes in XHTML	19
Deprecated Syntax	20
Inline Code versus External Files	21
Document Modes	22
The <noscript> Element	23
Summary	24
CHAPTER 3: LANGUAGE BASICS	25
Syntax	25
Case-Sensitivity	26
Identifiers	26

Comments	26
Strict Mode	27
Statements	27
Keywords and Reserved Words	28
Variables	29
The 'var' Keyword	29
var Declaration Scope	29
var Declaration Hoisting	30
'let' Declarations	31
Temporal Dead Zone	32
Global Declarations	32
Conditional Declaration	32
let Declaration in for Loops	34
'const' Declarations	34
Declaration Styles and Best Practices	35
Don't Use var	36
Prefer const Over let	36
Data Types	36
The typeof Operator	36
The Undefined Type	37
The Null Type	39
The Boolean Type	40
The Number Type	41
Floating-Point Values	41
Range of Values	42
NaN	43
Number Conversions	44
The String Type	46
Character Literals	47
The Nature of Strings	48
Converting to a String	48
Template Literals	49
Interpolation	50
Template Literal Tag Functions	51
Raw Strings	53
The Symbol Type	54
Basic Symbol Use	54
Using the Global Symbol Registry	55
Using Symbols as Properties	56
Well-Known Symbols	57
The Object Type	67

Operators	68
Unary Operators	68
Increment/Decrement	68
Unary Plus and Minus	70
Bitwise Operators	72
Bitwise NOT	73
Bitwise AND	74
Bitwise OR	74
Bitwise XOR	75
Left Shift	76
Signed Right Shift	76
Unsigned Right Shift	76
Boolean Operators	77
Logical NOT	77
Logical AND	78
Logical OR	79
Multiplicative Operators	80
Multiply	80
Divide	81
Modulus	82
Exponentiation Operator	82
Additive Operators	82
Add	83
Subtract	84
Relational Operators	85
Equality Operators	86
Equal and Not Equal	86
Identically Equal and Not Identically Equal	87
Conditional Operator	88
Assignment Operators	88
Comma Operator	89
Statements	90
The if Statement	90
The do-while Statement	90
The while Statement	91
The for Statement	91
The for-in Statement	92
The for-of Statement	93
Labeled Statements	93
The break and continue Statements	94

The with Statement	95
The switch Statement	96
Functions	98
Summary	100
CHAPTER 4: VARIABLES, SCOPE, AND MEMORY	101
<hr/>	
Primitive and Reference Values	101
Dynamic Properties	102
Copying Values	103
Argument Passing	103
Determining Type	105
Execution Context and Scope	106
Scope Chain Augmentation	108
Variable Declaration	109
Function Scope Declaration Using var	109
Block Scope Declaration Using let	111
Constant Declaration Using const	112
Identifier Lookup	113
Garbage Collection	114
Mark-and-Sweep	115
Reference Counting	115
Performance	116
Managing Memory	117
Performance Boosts with const and let Declarations	118
Hidden Classes and the delete Operation	118
Memory Leaks	119
Static Allocation and Object Pools	120
Summary	122
CHAPTER 5: BASIC REFERENCE TYPES	125
<hr/>	
The Date Type	126
Inherited Methods	128
Date-Formatting Methods	129
Date/Time Component Methods	129
The RegExp Type	131
RegExp Instance Properties	134
RegExp Instance Methods	135
RegExp Constructor Properties	137
Pattern Limitations	139
Primitive Wrapper Types	139
The Boolean Type	141
The Number Type	141

The isInteger() Method and Safe Integers	143
The String Type	144
The JavaScript Character	144
The normalize() Method	147
String-Manipulation Methods	148
String Location Methods	150
String Inclusion Methods	151
The trim() Method	151
The repeat() Method	152
The padStart() and padEnd() Methods	152
String Iterators and Destructuring	152
String Case Methods	153
String Pattern-Matching Methods	153
The localeCompare() Method	156
HTML Methods	157
Singleton Built-in Objects	157
The Global Object	157
URI-Encoding Methods	158
The eval() Method	159
Global Object Properties	160
The Window Object	161
The Math Object	161
Math Object Properties	162
The min() and max() Methods	162
Rounding Methods	163
The random() Method	163
Other Methods	164
Summary	165
CHAPTER 6: COLLECTION REFERENCE TYPES	167
<hr/>	
The Object Type	167
The Array Type	170
Creating Arrays	170
Array Holes	172
Indexing into Arrays	174
Detecting Arrays	175
Iterator Methods	176
Copy and Fill Methods	176
Conversion Methods	179
Stack Methods	180
Queue Methods	181
Reordering Methods	182

Manipulation Methods	184
Search and Location Methods	186
Strict Equivalence	186
Predicate Search	187
Iterative Methods	188
Reduction Methods	189
Typed Arrays	190
History	190
WebGL	190
Emergence of Typed Arrays	191
Using ArrayBuffers	191
DataViews	192
ElementType	193
Big-Endian and Little-Endian	194
Corner Cases	195
Typed Arrays	196
Typed Array Behavior	197
Merging, Copying, and Changing Typed Arrays	198
Underflow and Overflow	200
The Map Type	201
Basic API	201
Order and Iteration	203
Choosing Between Objects and Maps	206
Memory Profile	206
Insertion Performance	206
Lookup Performance	206
Delete Performance	206
The WeakMap Type	206
Basic API	207
Weak Keys	208
Non-Iterable Keys	209
Utility	209
Private Variables	209
DOM Node Metadata	211
The Set Type	211
Basic API	211
Order and Iteration	213
Defining Formal Set Operations	215
The WeakSet Type	217
Basic API	217
Weak Keys	219
Non-Iterable Values	219

Utility	219
Iteration and Spread Operators	220
Summary	222
CHAPTER 7: ITERATORS AND GENERATORS	225
<hr/>	
Introduction to Iteration	225
The Iterator Pattern	226
The Iterable Protocol	227
The Iterator Protocol	229
Custom Iterator Definition	231
Early Termination of Iterators	233
Generators	236
Generator Basics	236
Interrupting Execution with “yield”	238
Using a Generator Object as an Iterable	239
Using “yield” for Input and Output	240
Yielding an Iterable	242
Recursive Algorithms Using yield*	244
Using a Generator as the Default Iterator	246
Early Termination of Generators	247
The return() Method	247
The throw() Method	248
Summary	249
CHAPTER 8: OBJECTS, CLASSES, AND OBJECT-ORIENTED PROGRAMMING	251
<hr/>	
Understanding Objects	251
Types of Properties	252
Data Properties	252
Accessor Properties	254
Defining Multiple Properties	255
Reading Property Attributes	256
Merging Objects	257
Object Identity and Equality	260
Enhanced Object Syntax	261
Property Value Shorthand	261
Computed Property Keys	262
Concise Method Syntax	263
Object Destructuring	264
Nested Destructuring	266

Partial Destructuring Completion	267
Parameter Context Matching	268
Object Creation	268
Overview	268
The Factory Pattern	269
The Function Constructor Pattern	269
Constructors as Functions	272
Problems with Constructors	272
The Prototype Pattern	273
How Prototypes Work	274
Understanding the Prototype Hierarchy	278
Prototypes and the “in” Operator	281
Property Enumeration Order	283
Object Iteration	284
Alternate Prototype Syntax	285
Dynamic Nature of Prototypes	286
Native Object Prototypes	287
Problems with Prototypes	288
Inheritance	289
Prototype Chaining	289
Default Prototypes	291
Prototype and Instance Relationships	291
Working with Methods	292
Problems with Prototype Chaining	294
Constructor Stealing	294
Passing Arguments	295
Problems with Constructor Stealing	296
Combination Inheritance	296
Prototypal Inheritance	297
Parasitic Inheritance	298
Parasitic Combination Inheritance	299
Classes	302
Class Definition Basics	302
Class Composition	303
The Class Constructor	303
Instantiation	304
Understanding Classes as Special Functions	306
Instance, Prototype, and Class Members	307
Instance Members	307
Prototype Methods and Accessors	308
Static Class Methods and Accessors	309

Non-Function Prototype and Class Members	310
Iterator and Generator Methods	311
Inheritance	312
Inheritance Basics	312
Constructors, HomeObjects, and super()	313
Abstract Base Classes	316
Inheriting from Built-in Types	317
Class Mixins	318
Summary	320
CHAPTER 9: PROXIES AND REFLECT	323
Proxy Fundamentals	324
Creating a Passthrough Proxy	324
Defining Traps	325
Trap Parameters and the Reflect API	326
Trap Invariants	328
Revocable Proxies	329
Utility of the Reflect API	329
Reflect API vs. Object API	330
Status Flags	330
Supplanting Operators with First-Class Functions	331
Safe Function Application	331
Proxying a Proxy	331
Proxy Considerations and Shortcomings	332
'this' Inside a Proxy	332
Proxies and Internal Slots	333
Proxy Traps and Reflect Methods	333
get()	333
Return value	334
Intercepted operations	334
Trap handler parameters	334
Trap invariants	334
set()	334
Return value	335
Intercepted operations	335
Trap handler parameters	335
Trap invariants	335
has()	335
Return value	336
Intercepted operations	336
Trap handler parameters	336

Trap invariants	336
defineProperty()	336
Return value	336
Intercepted operations	336
Trap handler parameters	337
Trap invariants	337
getOwnPropertyDescriptor()	337
Return value	337
Intercepted operations	337
Trap handler parameters	337
Trap invariants	338
deleteProperty()	338
Return value	338
Intercepted operations	338
Trap handler parameters	338
Trap invariants	339
ownKeys()	339
Return value	339
Intercepted operations	339
Trap handler parameters	339
Trap invariants	339
getPrototypeOf()	339
Return value	340
Intercepted operations	340
Trap handler parameters	340
Trap invariants	340
setPrototypeOf()	340
Return value	341
Intercepted operations	341
Trap handler parameters	341
Trap invariants	341
isExtensible()	341
Return value	341
Intercepted operations	341
Trap handler parameters	342
Trap invariants	342
preventExtensions()	342
Return value	342
Intercepted operations	342
Trap handler parameters	342
Trap invariants	342

apply()	342
Return value	343
Intercepted operations	343
Trap handler parameters	343
Trap invariants	343
construct()	343
Return value	343
Intercepted operations	344
Trap handler parameters	344
Trap invariants	344
Proxy Patterns	344
Tracking Property Access	344
Hidden Properties	345
Property Validation	345
Function and Constructor Parameter Validation	346
Data Binding and Observables	347
Summary	348
CHAPTER 10: FUNCTIONS	349
Arrow Functions	350
Function Names	351
Understanding Arguments	353
Arguments in Arrow Functions	355
No Overloading	355
Default Parameter Values	356
Default Parameter Scope and Temporal Dead Zone	358
Spread Arguments and Rest Parameters	359
Spread Arguments	359
Rest Parameter	360
Function Declarations versus Function Expressions	361
Functions as Values	362
Function Internals	364
arguments	364
this	365
caller	366
new.target	367
Function Properties and Methods	367
Function Expressions	370
Recursion	372
Tail Call Optimization	373
Tail Call Optimization Requirements	374
Coding for Tail Call Optimization	375

Closures	376
The this Object	379
Memory Leaks	381
Immediately Invoked Function Expressions	382
Private Variables	384
Static Private Variables	385
The Module Pattern	387
The Module-Augmentation Pattern	388
Summary	389
CHAPTER 11: PROMISES AND ASYNC FUNCTIONS	391
<hr/>	
Introduction to Asynchronous Programming	392
Synchronous vs. Asynchronous JavaScript	392
Legacy Asynchronous Programming Patterns	393
Returning Asynchronous Values	393
Handling Failure	394
Nesting Asynchronous Callbacks	394
Promises	395
The Promises/A+ Specification	395
Promise Basics	395
The Promise State Machine	396
Resolved Values, Rejection Reasons, and Utility of Promises	396
Controlling Promise State with the Executor	397
Promise Casting with Promise.resolve()	398
Promise Rejection with Promise.reject()	399
Synchronous/Asynchronous Execution Duality	399
Promise Instance Methods	400
Implementing the Thenable Interface	400
Promise.prototype.then()	400
Promise.prototype.catch()	403
Promise.prototype.finally()	404
Non-Reentrant Promise Methods	405
Sibling Handler Order of Execution	407
Resolved Value and Rejected Reason Passing	408
Rejecting Promises and Rejection Error Handling	408
Promise Chaining and Composition	410
Promise Chaining	410
Promise Graphs	413
Parallel Promise Composition with Promise.all() and Promise.race()	414
Serial Promise Composition	416

Promise Extensions	418
Promise Canceling	418
Promise Progress Notifications	419
Async Functions	421
Async Function Basics	422
The async keyword	422
The await keyword	424
Restrictions on await	426
Halting and Resuming Execution	427
Strategies for Async Functions	430
Implementing Sleep()	430
Maximizing Parallelization	431
Serial Promise Execution	434
Stack Traces and Memory Management	434
Summary	435
CHAPTER 12: THE BROWSER OBJECT MODEL	437
The window Object	438
The Global Scope	438
Window Relationships	439
Window Position and Pixel Ratio	439
Pixel Ratios	439
Window Size	440
Window Viewport Position	441
Navigating and Opening Windows	442
Popping Up Windows	442
Security Restrictions	445
Pop-up Blockers	445
Intervals and Timeouts	446
System Dialogs	448
The location Object	450
Query String Arguments	451
URLSearchParams	452
Manipulating the Location	452
The navigator Object	454
Detecting Plug-ins	456
Legacy Internet Explorer Plugin Detection	457
Registering Handlers	459
The screen Object	459
The history Object	460

Navigation	460
History State Management	461
Summary	462
CHAPTER 13: CLIENT DETECTION	465
<hr/>	
Capability Detection	466
Safer Capability Detection	467
Using Capability Detection for Browser Analysis	468
Detecting Feature Support	468
Detecting Browser Identity	468
Capability Detection Limitations	469
User-Agent Detection	470
History of User-Agent Composition	470
Early Browsers	470
Netscape Navigator 3 and Internet Explorer 3	471
Netscape Communicator 4 and Internet Explorer 4 Through 8	472
Gecko	473
WebKit	475
Konqueror	476
Chrome	476
Opera	476
iOS and Android	478
Using User-Agent for Browser Analysis	478
Spoofing a User-Agent	479
Using User-Agents for Browser Analysis	479
Software and Hardware Detection	480
Browser and Operating System Identification	481
The navigator.oscpu Property	481
The navigator.vendor Property	481
The navigator.platform Property	481
The screen.colorDepth and screen.pixelDepth Properties	482
The screen.orientation Property	482
Browser Metadata	482
The Geolocation API	483
Connection State and the NetworkInformation API	486
Battery Status API	487
Hardware	489
Processor Cores	489
Device Memory	489
Maximum Touch Points	489
Summary	489

CHAPTER 14: THE DOCUMENT OBJECT MODEL	491
Hierarchy of Nodes	492
The Node Type	492
The nodeName and nodeValue Properties	493
Node Relationships	494
Manipulating Nodes	495
Other Methods	497
The Document Type	498
Document Children	498
Document Information	499
Locating Elements	500
Special Collections	502
DOM Conformance Detection	503
Document Writing	504
The Element Type	506
HTML Elements	507
Getting Attributes	510
Setting Attributes	511
The attributes Property	511
Creating Elements	513
Element Children	513
The Text Type	514
Creating Text Nodes	515
Normalizing Text Nodes	516
Splitting Text Nodes	517
The Comment Type	517
The CDATASection Type	518
The DocumentType Type	518
The DocumentFragment Type	519
The Attr Type	520
Working with the DOM	521
Dynamic Scripts	521
Dynamic Styles	523
Manipulating Tables	525
Using NodeLists	528
Mutation Observers	529
Basic usage	529
The observe() method	529
Working with Callbacks and MutationRecords	530
The disconnect() method	532

Multiplexing a MutationObserver	532
Reusing a MutationObserver	533
Controlling the Observer scope with MutationObserverInit	534
Observing attribute mutations	535
Observing character data mutations	536
Observing child mutations	537
Observing subtree mutations	539
Async Callbacks and the Record Queue	540
Behavior of the Record Queue	540
The takeRecords() method	541
Performance, Memory, and Garbage Collection	541
MutationObserver References	541
MutationRecord References	542
Summary	542
CHAPTER 15: DOM EXTENSIONS	543
Selectors API	544
The querySelector() Method	544
The querySelectorAll() Method	544
The matches() Method	545
Element Traversal	546
HTML5	547
Class-Related Additions	547
The getElementsByClassName() Method	547
The classList Property	548
Focus Management	549
Changes to HTMLDocument	550
The readyState Property	550
Compatibility Mode	550
The head Property	551
Character Set Properties	551
Custom Data Attributes	551
Markup Insertion	552
The innerHTML Property	552
Using innerHTML in Legacy Internet Explorer	553
The outerHTML Property	554
The insertAdjacentHTML() and insertAdjacentText() Methods	555
Memory and Performance Issues	555
Cross-Site Scripting Considerations	556
The scrollIntoView() Method	556
Proprietary Extensions	557
The children Property	557

The contains() Method	557
Markup Insertion	558
The innerText Property	558
The outerText Property	560
Scrolling	560
Summary	560
CHAPTER 16: DOM LEVELS 2 AND 3	563
<hr/>	
DOM Changes	564
XML Namespaces	564
Changes to Node	566
Changes to Document	567
Changes to Element	567
Changes to NamedNodeMap	568
Other Changes	568
Changes to DocumentType	568
Changes to Document	569
Changes to Node	570
Changes to iframes	571
Styles	572
Accessing Element Styles	572
DOM Style Properties and Methods	573
Computed Styles	575
Working with Style Sheets	576
CSS Rules	577
Creating Rules	578
Deleting Rules	579
Element Dimensions	579
Offset Dimensions	579
Client Dimensions	581
Scroll Dimensions	582
Determining Element Dimensions	584
Traversals	584
Nodelerator	585
TreeWalker	588
Ranges	590
Ranges in the DOM	590
Simple Selection in DOM Ranges	591
Complex Selection in DOM Ranges	592
Interacting with DOM Range Content	593
Inserting DOM Range Content	596
Collapsing a DOM Range	597

Comparing DOM Ranges	597
Cloning DOM Ranges	598
Cleanup	598
Summary	599
CHAPTER 17: EVENTS	601
<hr/>	
Event Flow	602
Event Bubbling	602
Event Capturing	603
DOM Event Flow	603
Event Handlers	604
HTML Event Handlers	604
DOM Level 0 Event Handlers	606
DOM Level 2 Event Handlers	607
Internet Explorer Event Handlers	608
Cross-Browser Event Handlers	610
The Event Object	611
The DOM Event Object	611
The Internet Explorer Event Object	615
The Cross-Browser Event Object	617
Event Types	619
UI Events	619
The load Event	620
The unload Event	622
The resize Event	623
The scroll Event	624
Focus Events	624
Mouse and Wheel Events	625
Client Coordinates	627
Page Coordinates	628
Screen Coordinates	628
Modifier Keys	629
Related Elements	630
Buttons	631
Additional Event Information	632
The mousewheel Event	633
Touch Device Support	633
Accessibility Issues	634
Keyboard and Text Events	634
Key Codes	635
Character Codes	636
DOM Level 3 Changes	637

The textInput Event	638
Keyboard Events on Devices	639
Composition Events	640
Mutation Events	641
HTML5 Events	641
The contextmenu Event	641
The beforeunload Event	643
The DOMContentLoaded Event	643
The readystatechange Event	644
The pageshow and pagehide Events	645
The hashchange Event	647
Device Events	647
The orientationchange Event	647
The deviceorientation Event	648
The devicemotion Event	650
Touch and Gesture Events	651
Touch Events	651
Gesture Events	653
Event Reference	654
Memory and Performance	659
Event Delegation	659
Removing Event Handlers	661
Simulating Events	662
DOM Event Simulation	663
Simulating Mouse Events	663
Simulating Keyboard Events	664
Simulating Other Events	667
Custom DOM Events	667
Internet Explorer Event Simulation	668
Summary	669
CHAPTER 18: ANIMATION AND GRAPHICS WITH CANVAS	671
<hr/>	
Using requestAnimationFrame	672
Early Animation Loops	672
Problems with Intervals	673
requestAnimationFrame	673
cancelAnimationFrame	674
Performance Throttling with requestAnimationFrame	674
Basic Canvas Usage	676
The 2D Context	677
Fills and Strokes	677
Drawing Rectangles	677

Drawing Paths	679
Drawing Text	681
Transformations	683
Drawing Images	686
Shadows	687
Gradients	687
Patterns	689
Working with Image Data	689
Compositing	691
WebGL	692
The WebGL Context	693
WebGL Basics	693
Constants	694
Method Naming	695
Getting Ready to Draw	695
Viewports and Coordinates	695
Buffers	696
Errors	697
Shaders	697
Drawing	701
Textures	703
Reading Pixels	703
WebGL1 versus WebGL2	704
Summary	705

CHAPTER 19: SCRIPTING FORMS **707**

Form Basics	707
Submitting Forms	708
Resetting Forms	709
Form Fields	710
Common Form-Field Properties	711
Common Form-Field Methods	713
Common Form-Field Events	714
Scripting Text Boxes	715
Text Selection	716
The select Event	716
Retrieving Selected Text	717
Partial Text Selection	717
Input Filtering	718
Blocking Characters	719
Dealing with the Clipboard	720
Automatic Tab Forward	721

HTML5 Constraint Validation API	723
Required Fields	723
Alternate Input Types	723
Numeric Ranges	724
Input Patterns	724
Checking Validity	725
Disabling Validation	726
Scripting Select Boxes	726
Options Selection	728
Adding Options	730
Removing Options	730
Moving and Reordering Options	731
Form Serialization	732
Rich Text Editing	734
Using contenteditable	734
Interacting with Rich Text	735
Rich Text Selections	738
Rich Text in Forms	740
Summary	741
CHAPTER 20: JAVASCRIPT APIS	743
Atomics and SharedArrayBuffer	744
SharedArrayBuffer	744
Atomics Basics	745
Atomic Arithmetic and Bitwise Methods	745
Atomic Reads and Writes	747
Atomic Exchanges	748
Atomics Futex Operations and Locks	749
Cross-Context Messaging	751
Encoding API	753
Encoding Text	753
Bulk Encoding	753
Stream Encoding	754
Decoding Text	755
Bulk Decoding	755
Stream Decoding	756
Blob and File APIs	758
The File Type	758
The FileReader Type	759
The FileReaderSync Type	761
Blobs and Partial Reads	761
Object URLs and Blobs	762

Drag-and-Drop File Reading	763
Media Elements	764
Properties	765
Events	767
Custom Media Players	768
Codec Support Detection	769
The Audio Type	770
Native Drag and Drop	770
Drag-and-Drop Events	770
Custom Drop Targets	771
The dataTransfer Object	772
dropEffect and effectAllowed	773
Draggability	774
Additional Members	774
Notifications API	775
Notification Permissions	775
Showing and Hiding Notification	775
Notification Lifecycle Callbacks	776
Page Visibility API	776
Streams API	777
Introduction to Streams	778
Chunks, Internal Queues, and Backpressure	778
Readable Streams	779
Using the ReadableStreamDefaultController	779
Using the ReadableStreamDefaultReader	780
Writable Streams	781
Creating a WritableStream	781
Using a WritableStreamDefaultWriter	781
Transform Streams	782
Piping Streams	784
Timing APIs	785
High Resolution Time API	786
Performance Timeline API	788
User Timing API	788
Navigation Timing API	789
Resource Timing API	790
Web Components	791
HTML Templates	791
Using a DocumentFragment	792
Using <template> tags	793
Template Scripts	794

Shadow DOM	795
Introduction to Shadow DOM	795
Creating a Shadow DOM	796
Using a Shadow DOM	797
Composition and Shadow DOM Slots	799
Event Retargeting	801
Custom Elements	802
Defining a Custom Element	802
Adding Web Component Content	804
Using Custom Element Lifecycle Hooks	805
Reflecting Custom Element Attributes	806
Upgrading Custom Elements	807
The Web Cryptography API	808
Random Number Generation	808
Using the SubtleCrypto Object	810
Generating Cryptographic Digests	810
CryptoKeys and Algorithms	812
Generating CryptoKeys	814
Exporting and Importing Keys	816
Deriving Keys from Master Keys	817
Signing and Verifying Messages with Asymmetric Keys	819
Encrypting and Decrypting with Symmetric Keys	820
Wrapping and Unwrapping a Key	821
Summary	822
CHAPTER 21: ERROR HANDLING AND DEBUGGING	823
<hr/>	
Browser Error Reporting	824
Desktop Consoles	824
Mobile Consoles	824
Error Handling	825
The try-catch Statement	825
The finally Clause	826
Error Types	826
Usage of try-catch	828
Throwing Errors	829
When to Throw Errors	830
Throwing Errors versus try-catch	831
The error Event	831
Error-Handling Strategies	832
Identify Where Errors Might Occur	833
Static Code Analyzer	833

Type Coercion Errors	833
Data Type Errors	835
Communication Errors	837
Distinguishing between Fatal and Nonfatal Errors	838
Log Errors to the Server	839
Debugging Techniques	840
Logging Messages to a Console	840
Understanding the Console Runtime	841
Using the JavaScript Debugger	842
Logging Messages to the Page	842
Shimming Console Methods	843
Throwing Errors	843
Common Legacy Internet Explorer Errors	844
Invalid Character	844
Member Not Found	845
Unknown Runtime Error	845
Syntax Error	845
The System Cannot Locate the Resource Specified	846
Summary	846
CHAPTER 22: XML IN JAVASCRIPT	849
<hr/>	
XML DOM Support in Browsers	849
DOM Level 2 Core	850
The DOMParser Type	850
The XMLSerializer Type	851
XPath Support in Browsers	852
DOM Level 3 XPath	852
Single Node Results	854
Simple Type Results	854
Default Type Results	855
Namespace Support	856
XSLT Support in Browsers	857
The XSLTProcessor Type	857
Using Parameters	858
Resetting the Processor	859
Summary	859
CHAPTER 23: JSON	861
<hr/>	
Syntax	862
Simple Values	862
Objects	862
Arrays	863

Parsing and Serialization	864
The JSON Object	865
Serialization Options	866
Filtering Results	866
String Indentation	867
The toJSON() Method	868
Parsing Options	869
Summary	870
CHAPTER 24: NETWORK REQUESTS AND REMOTE RESOURCES	871
<hr/>	
The XMLHttpRequest Object	872
XHR Usage	872
HTTP Headers	875
GET Requests	876
POST Requests	877
XMLHttpRequest Level 2	878
The FormData Type	878
Timeouts	879
The overrideMimeType() Method	879
Progress Events	880
The load Event	880
The progress Event	881
Cross-Origin Resource Sharing	881
Preflighted Requests	883
Credentialed Requests	883
Alternate Cross-Domain Techniques	884
Image Pings	884
JSONP	884
The Fetch API	885
Basic API Utilization	886
Dispatching a Request	886
Reading a Response	886
Handling Status Codes and Request Failures	887
Custom Fetch Options	888
Common Fetch Patterns	893
Sending JSON Data	893
Sending Parameters in a Request Body	893
Sending Files	893
Loading Files as Blobs	894
Sending a Cross-Origin Request	894
Aborting a Request	894
The Headers Object	895

Exploring Headers-Map Similarity	895
Unique Features of the Headers Object	896
Header Guards	896
The Request Object	897
Creating Request Objects	897
Cloning Request Objects	898
Using Request Objects with fetch()	900
The Response Object	901
Creating Response Objects	901
Reading Response Status Information	903
Cloning Response Objects	905
Requests, Responses, and the Body Mixin	906
Body.text()	906
Body.json()	906
Body.formData()	907
Body.arrayBuffer()	907
Body.blob()	908
Single-Use Streams	908
Using a ReadableStream Body	909
The Beacon API	914
Web Sockets	915
The API	915
Sending/Receiving Data	916
Other Events	916
Security	917
Summary	918
CHAPTER 25: CLIENT-SIDE STORAGE	919
<hr/>	
Cookies	919
Restrictions	920
Cookie Parts	921
Cookies in JavaScript	922
Subcookies	925
Cookie Considerations	928
Web Storage	929
The Storage Type	929
The sessionStorage Object	930
The localStorage Object	932
The storage Event	932
Limits and Restrictions	933
IndexedDB	933
Databases	933

Object Stores	934
Transactions	935
Insertion	936
Querying with Cursors	937
Key Ranges	939
Setting Cursor Direction	940
Indexes	941
Concurrency Issues	943
Limits and Restrictions	943
Summary	944
CHAPTER 26: MODULES	945
Understanding the module pattern	946
Module Identifiers	946
Module Dependencies	946
Module Loading	946
Entry Points	947
Asynchronous Dependencies	948
Programmatic Dependencies	948
Static Analysis	948
Circular Dependencies	949
Improvising Module Systems	950
Working with pre-ES6 module loaders	953
CommonJS	953
Asynchronous Module Definition	956
Universal Module Definition	957
Module Loader Deprecation	957
Working with ES6 modules	958
Module Tagging and Definition	958
Module Loading	959
Module Behavior	959
Module Exports	960
Module Imports	963
Module Passthrough Exports	965
Worker Modules	965
Backwards Compatibility	966
Summary	967
CHAPTER 27: WORKERS	969
Introduction to Workers	970
Comparing Workers and Threads	970
Types of Workers	971

Dedicated Web Worker	971
Shared Web Worker	971
Service Worker	971
The WorkerGlobalScope	971
WorkerGlobalScope Properties and Methods	972
Subclasses of WorkerGlobalScope	972
Dedicated Workers	973
Dedicated Worker Basics	973
Creating a Dedicated Worker	973
Worker Security Restrictions	974
Using the Worker Object	975
The DedicatedWorkerGlobalScope	976
Dedicated Workers and Implicit MessagePorts	976
Understanding the Dedicated Worker Lifecycle	977
Configuring Worker Options	979
Creating a Worker from Inline JavaScript	979
Dynamic Script Execution Inside a Worker	980
Delegating Tasks to Subworkers	982
Handling Worker Errors	983
Communicating with a Dedicated Worker	983
Communicating with postMessage()	983
Communicating with MessageChannel	984
Communicating with BroadcastChannel	986
Worker Data Transfer	987
Structured Clone Algorithm	987
Transferable Objects	988
SharedArrayBuffer	990
Worker Pools	993
Shared Workers	997
Shared Worker Basics	997
Creating a Shared Worker	997
SharedWorker Identity and Single Occupancy	998
Using the SharedWorker Object	999
The SharedWorkerGlobalScope	999
Understanding the Shared Worker Lifecycle	1000
Connecting to a Shared Worker	1001
Service Workers	1003
Service Worker Basics	1003
The ServiceWorkerContainer	1004
Creating a Service Worker	1004
Using the ServiceWorkerContainer Object	1005

Using the ServiceWorkerRegistration Object	1006
Using the ServiceWorker Object	1007
Service Worker Security Restrictions	1008
The ServiceWorkerGlobalScope	1008
Service Worker Scope Limitations	1010
The Service Worker Cache	1012
The CacheStorage Object	1013
The Cache Object	1014
Maximum Cache Storage	1017
Service Worker Clients	1017
Service Workers and Consistency	1018
Understanding the Service Worker Lifecycle	1019
The Parsed State	1020
The Installing State	1020
The Installed State	1021
The Activating State	1022
The Activated State	1023
The Redundant State	1024
Updating a Service Worker	1024
Inversion of Control and Service Worker Persistence	1024
Managing Service Worker File Caching with updateViaCache	1025
Forced Service Worker Operation	1025
Service Worker Messaging	1026
Intercepting a fetch Event	1028
Return from Network	1028
Return from Cache	1029
Return from Network with Cache Fallback	1029
Return from Cache with Network Fallback	1029
Generic Fallback	1029
Push Notifications	1030
Displaying Notifications	1030
Handling Notification Events	1031
Subscribing to Push Events	1031
Handling Push Events	1032
Summary	1033
CHAPTER 28: BEST PRACTICES	1035
Maintainability	1035
What Is Maintainable Code?	1036
Code Conventions	1036

Readability	1037
Variable and Function Naming	1037
Variable Type Transparency	1038
Loose Coupling	1039
Decouple HTML/JavaScript	1039
Decouple CSS/JavaScript	1041
Decouple Application Logic/Event Handlers	1041
Programming Practices	1043
Respect Object Ownership	1043
Avoid Globals	1044
Avoid Null Comparisons	1045
Use Constants	1046
Performance	1047
Be Scope-Aware	1047
Avoid Global Lookups	1047
Avoid the with Statement	1048
Choose the Right Approach	1049
Avoid Unnecessary Property Lookup	1049
Optimize Loops	1050
Unrolling Loops	1051
Avoid Double Interpretation	1053
Other Performance Considerations	1054
Minimize Statement Count	1054
Multiple Variable Declarations	1054
Insert Iterative Values	1055
Use Array and Object Literals	1055
Optimize DOM Interactions	1056
Minimize Live Updates	1056
Use innerHTML	1057
Use Event Delegation	1058
Beware of HTMLCollections	1058
Deployment	1059
Build Process	1059
File Structure	1060
Task Runners	1060
Tree Shaking	1060
Module Bundlers	1061
Validation	1061
Compression	1062

Code Minification	1062
JavaScript Compilation	1063
JavaScript Transpilation	1063
HTTP Compression	1064
Summary	1064
APPENDIX A: ES2018 AND ES2019	1067
<hr/>	
APPENDIX B: STRICT MODE	1087
<hr/>	
APPENDIX C: JAVASCRIPT LIBRARIES AND FRAMEWORKS	1095
<hr/>	
APPENDIX D: JAVASCRIPT TOOLS	1101
<hr/>	
<i>INDEX</i>	1113

FOREWORD

The industrial revolution was built with steel, and the Internet revolution has been built with JavaScript. Forged and strengthened through constant iteration over the past 25 years, JavaScript’s dominance in application development is now hard to question, but that wasn’t always the case.

It took only ten days for Brendan Eich to make the first version of JavaScript. It felt fragile, but as history would have it, first impressions aren’t everything. Today, every aspect of JavaScript—every detail you’ll learn in this book—is the product of hours of debate. Not every decision is ideal and no programming language is perfect, but if you judge one by its ubiquity alone, JavaScript perhaps comes close. It is the only language you can deploy everywhere: servers, desktop browsers, mobile web browsers, and even native mobile applications.

JavaScript is now used by software engineers of all experience levels and backgrounds. It’s used by those who care about well-designed, elegant software as well as those who simply want to hack things together to achieve business goals.

How you’ll use it is entirely up to you. That power is yours.

Over my last 15 years of developing software, JavaScript tools and best practices have changed dramatically. My experience with the language began in 2004—back when Geocities, Yahoo Groups, and Macromedia Flash player dominated the scene. JavaScript felt like a toy, and I played with some of the popular sandboxes at the time: RSS and MySpace Profile Pages. Helping others modify and customize their personal sites felt like the Wild West and got me hooked.

When I started my first company, configuring a host for your database took days and JavaScript was embedded into your HTML. There were no frontend “applications”—it was all mostly just piecemeal functions. As Ajax became more popular, spearheaded by jQuery, a new world unfolded and applications grew far more robust. That movement accelerated to a breakneck speed and then, suddenly, powerful frameworks were released. Front-end models! Data binding! Route management! Reactive views! It was during this front-end revolution that I moved to Silicon Valley to help start a company founded by Lady Gaga, and quickly, millions of users began using my code. Having now been in Silicon Valley for quite some time, I’ve led open-source contributions, mentored more software engineers than I can count, and hit a bit of luck, too. My last company was acquired by Stripe in 2018, where I now work to build economic infrastructure for the Internet.

I had the pleasure of meeting Matt the day he first flew out to Palo Alto to lead engineering at a small startup. It was called Claco, and I had recently joined on as an advisor. His energy and passion for great software was apparent, and the fledgling company quickly produced a beautiful product. As has been the Silicon Valley standard since the days of HP, this startup was founded out of a house. But this was no normal home. It was a “hacker house,” where ten or so brilliant software engineers lived at any given moment. Although this was not high-class living—discarded bunk beds and chairs found on the street were commonplace—the quantity and quality of code written there, on a daily basis, was staggering. After work hours, most would simply shift their focus and instead build their side projects

for another couple of hours. Those who didn't know how to code were frequently inspired, would get the itch to learn, and become capable within just weeks.

Matt was a driving force at the center of this productivity. He was the most experienced software engineer in the house, and also happened to be the cleanest and most professional, too. Having a formal degree in computer engineering wasn't the norm, so when you saw algorithms, performance calculations, and code written on the windows or whiteboard, you knew Matt was building his next big project. As I got to know him, we became close friends. His intellect, fondness for mentorship, and ability to turn most anything into an A- joke were all qualities I admired.

Even though Matt is an incredibly talented software engineer and engineering leader, it is truly his unique set of experiences and knowledge that make him one of the most qualified people in the world to write this book.

He hasn't just spent his time teaching others—he's done the work.

At Claco, he built out multiple entire products, end-to-end, to help teachers provide a better learning experience in their classrooms. At DoorDash, where he was the first engineer, he built out a robust logistics and delivery network that achieved hyper-growth and is now worth upwards of twelve billion dollars. Finally, at Google, Matt's software has been used by billions of people across the planet.

Massive ownership, massive growth, and massive scale. Most software engineers can go their entire career and experience only one of these, if they're lucky. Matt has not only done all three but has also become a best-selling author in his "spare time," having written two other books on JavaScript and Angular. Honestly, I just hope his next book unveils the time machine schematics he's clearly hiding from us.

This book is a robust tool filled to the brim with JavaScript knowledge and real-world perspectives. I'm excited for you to continue learning and build whatever you can dream up. Pick it apart, take notes, and don't forget to open up that code editor—after all, the internet revolution is still in the early days!

—Zach Tratar
Software engineer at Stripe
Former co-founder and CEO of Jobstart

INTRODUCTION

A tech lead at Google once shared with me a compelling perspective on JavaScript: It's not *really* a cohesive programming language—at least not in the formal sense. The ECMA-262 specification *defines* JavaScript, but there is no single true *implementation* of it. What's more, the language is far from hermetic. It swims in a veritable ocean of adjacent specifications that govern APIs for everything that JavaScript touches: the DOM, network requests, system hardware, storage, events, files, cryptography, and *hundreds* of others. Web browsers and their various JavaScript engines all implement these specifications as they see fit. Chrome has Blink/V8, Firefox has Gecko/SpiderMoney, and Safari has WebKit/JavaScriptCore. Browsers will run *nearly* all JavaScript in a way that conforms to the specifications, but the web is littered with examples of each browser's idiosyncrasies. Therefore, JavaScript is more accurately characterized as a constellation of browser implementations.

Although web purists might insist that JavaScript should not be an integral component of web pages, they must concede that the modern web is severely diminished without it. It is not hyperbolic to say that JavaScript is virtually inescapable: Phones, computers, tablets, televisions, game consoles, smart watches, refrigerators, and even cars now feature web browsers that run JavaScript. Nearly three billion people now use a smartphone that includes a web browser. The language's vibrant community churns out a deluge of high-quality open source projects. Browsers now feature first-class support for APIs that emulate native mobile apps. In Stack Overflow's 2019 Developer Survey, JavaScript was voted the most popular programming language for the seventh consecutive year.

The JavaScript renaissance is upon us.

In this book, JavaScript is covered from its very beginning in the earliest Netscape browsers to the present-day incarnations flush with support for a dizzying spectrum of browser technologies. The book covers a large number of advanced topics in meticulous detail, yet it ensures the reader understands how to use these topics and where they are appropriate. In short, you learn how to apply JavaScript solutions to business problems faced by web developers everywhere.

WHO THIS BOOK IS FOR

This book is aimed at three groups of readers:

- Experienced developers familiar with object-oriented programming who are looking to learn JavaScript as it relates to traditional OO languages such as Java and C++
- Web application developers attempting to enhance the usability of their web sites and web applications
- Novice JavaScript developers aiming to better understand the language

In addition, familiarity with the following related technologies is a strong indicator that this book is for you:

- Java
- PHP
- Python
- Ruby
- Golang
- HTML
- CSS

This book is not aimed at beginners lacking a basic computer science background or those looking to add some simple user interactions to websites. These readers should instead refer to Wrox's *Beginning JavaScript, 5th Edition* (Wiley, 2015).

WHAT THIS BOOK COVERS

Professional JavaScript for Web Developers, 4th Edition, provides a developer-level introduction, along with the more advanced and useful features of JavaScript.

The book begins with an exploration of how JavaScript originated and evolved into what it is today. A detailed discussion of the components that make up a JavaScript implementation follows, with specific focus on standards such as ECMAScript and the Document Object Model (DOM).

Building on that base, the book moves on to cover basic concepts of JavaScript, including classes, promises, iterators, and proxies. This is followed by an in-depth examination of client detection, events, animations, forms, errors, and JSON.

The last part of the book is focused on the newest and most important specifications that have emerged in the past few years. This includes fetch, modules, web workers, service workers, and a collection of emerging APIs.

HOW THIS BOOK IS STRUCTURED

This book comprises the following chapters:

- 1. What Is JavaScript?**—Explains the origins of JavaScript: where it came from, how it evolved, and what it is today. Concepts introduced include the relationship between JavaScript and ECMAScript, the Document Object Model (DOM), and the Browser Object Model (BOM). A discussion of the relevant standards from the European Computer Manufacturer's Association (ECMA) and the World Wide Web Consortium (W3C) is also included.

2. **JavaScript in HTML**—Examines how JavaScript is used in conjunction with HTML to create dynamic web pages. Introduces the various ways of embedding JavaScript into a page and includes a discussion surrounding the JavaScript content-type and its relationship to the `<script>` element.
3. **Language Basics**—Introduces basic language concepts, including syntax and flow control statements. Explains the syntactic similarities of JavaScript and other C-based languages and points out the differences. Type coercion is introduced as it relates to built-in operators. Covers all language primitives, including the `Symbol` type.
4. **Variables, Scope, and Memory**—Explores how variables are handled in JavaScript given their loosely typed nature. A discussion of the differences between primitive and reference values is included, as is information about execution context as it relates to variables. Also, a discussion about garbage collection in JavaScript covers how memory is reclaimed when variables go out of scope.
5. **Basic Reference Types**—Covers all of the details regarding JavaScript’s built-in reference types, such as `Date`, `RegExp`, primitives, and primitive wrappers. Each reference type is discussed both in theory and in how they relate to browser implementations.
6. **Collection Reference Types**—Continues the book’s coverage of built-in reference types with `Object`, `Array`, `Map`, `WeakMap`, `Set`, and `WeakSet`.
7. **Iterators and Generators**—Introduces two new fundamental concepts in recent versions of ECMAScript: iterators and generators. Each is discussed both in terms of its most fundamental behavior as well as how it is used in relation to existing language constructs.
8. **Objects, Classes, and Object-Oriented Programming**—Explains how to use classes and object-oriented programming in JavaScript. Begins with an in-depth discussion of the JavaScript `Object` type and continues into coverage of prototypal inheritance. Following this is a complete discussion of ES6 classes and how they are a close sibling of prototypal inheritance.
9. **Proxies and Reflect**—Introduces two closely related concepts: `Proxy` and the `Reflect` API. These can be used to intercept and shim additional behavior into fundamental operations within the language.
10. **Functions**—Explores one of the most powerful aspects of JavaScript: function expressions. Topics include closures, the `this` object, the module pattern, the creation of private object members, arrow functions, default parameters, and spread operators.
11. **Promises and Async Programming**—Introduces two new closely related asynchronous programming constructs: the `Promise` type and `async/await`. The chapter begins with a discussion of the asynchronous JavaScript paradigm and continues into coverage of how promises are used and their relationship to async functions.
12. **The Browser Object Model**—Introduces the Browser Object Model (BOM), which is responsible for objects allowing interaction with the browser itself. Each of the BOM objects is covered, including `window`, `document`, `location`, `navigator`, and `screen`.

13. **Client Detection**—Explains various approaches to detecting the client machine and its capabilities. Different techniques include capability detection and user-agent string detection. The chapter covers the pros and cons of each approach, as well as situational appropriateness.
14. **The Document Object Model**—Introduces the Document Object Model (DOM) objects available in JavaScript as defined in DOM Level 1. A brief introduction to XML and its relationship to the DOM gives way to an in-depth exploration of the entire DOM and how it allows developers to manipulate a page.
15. **DOM Extensions**—Explains how other APIs, as well as the browsers themselves, extend the DOM with more functionality. Topics include the Selectors API, the Element Traversal API, and HTML5 extensions.
16. **DOM Levels 2 and 3**—Builds on the previous two chapters, explaining how DOM Levels 2 and 3 augmented the DOM with additional properties, methods, and objects. Includes coverage of DOM4 additions, such as mutation observers.
17. **Events**—Explains the nature of events in JavaScript, where they originated, and how the DOM redefined how events should work.
18. **Animation and Graphics with Canvas**—Discusses the `<canvas>` tag and how to use it to create on-the-fly graphics. Both the 2D context and the WebGL (3D) context are covered, providing you with a good starting point for creating animations and games. Includes coverage of both WebGL1 and WebGL2.
19. **Scripting Forms**—Explores using JavaScript to enhance form interactions and work around browser limitations. Discussion focuses on individual form elements such as text boxes and select boxes and on data validation and manipulation.
20. **JavaScript APIs**—Covers an assortment of JavaScript APIs, including Atomics, Encoding, File, Blob, Notifications, Streams, Timing, Web Components, and Web Cryptography.
21. **Error Handling and Debugging**—Discusses how browsers handle errors in JavaScript code and presents several ways to handle errors. Debugging tools and techniques are also discussed for each browser, including recommendations for simplifying the debugging process.
22. **XML in JavaScript**—Presents the features of JavaScript used to read and manipulate eXtensible Markup Language (XML) data. Explains the differences in support and objects in various web browsers and offers suggestions for easier cross-browser coding. This chapter also covers the use of eXtensible Stylesheet Language Transformations (XSLT) to transform XML data on the client.
23. **JSON**—Introduces the JSON data format as an alternative to XML. Discusses browser-native JSON parsing and serialization as well as security considerations when using JSON.
24. **Network Requests and Remote Resources**—Explores all of the most common ways that data and assets are requested by the browser. Includes coverage of the legacy `XMLHttpRequest` as well as the modern Fetch API.

25. **Client-Side Storage**—Discusses how to detect when an application is offline and provides various techniques for storing data on the client machine. Begins with a discussion of the most commonly supported feature, cookies, and then discusses newer functionality such as Web Storage and IndexedDB.
26. **Modules**—Discusses the module pattern and its implications on codebases. Following this, the chapter covers pre-ES6 module loaders such as CommonJS, AMD, and UMD. Ends with detailed coverage on the new ES6 module pattern and how to use it properly.
27. **Workers**—Covers dedicated workers, shared workers, and service workers in-depth. Includes a discussion of how workers behave both at the operating system and browser level, as well as strategies for how best to use the various types of workers.
28. **Best Practices**—Explores approaches to working with JavaScript in an enterprise environment. Techniques for better maintainability are discussed, including coding techniques, formatting, and general programming practices. The chapter also covers execution performance and introduces several techniques for speed optimization. Last, the chapter covers deployment issues, including how to create a build process.

WHAT YOU NEED TO USE THIS BOOK

To run the samples in the book, you need the following:

- Any modern operating system, such as Windows, Linux, Mac OS, Android, or iOS
- Any modern browser, such as IE11+, Edge 12+, Firefox 26+, Chrome 39+, Safari 10+, Opera 26+, or iOS Safari 10+

The complete source code is available for download from <https://www.wiley.com/en-us/Professional+JavaScript+for+Web+Developers%2C+4th+Edition-p-9781119366447>.

1

What Is JavaScript?

WHAT'S IN THIS CHAPTER?

- Review of JavaScript history
- What JavaScript is
- How JavaScript and ECMAScript are related
- The different versions of JavaScript

WROX.COM DOWNLOADS FOR THIS CHAPTER

Please note that all the code examples for this chapter are available as a part of this chapter's code download on the book's website at www.wrox.com/go/projavascript4e on the Download Code tab.

When JavaScript first appeared in 1995, its main purpose was to handle some of the input validation that had previously been left to server-side languages such as Perl. Prior to that time, a round-trip to the server was needed to determine if a required field had been left blank or an entered value was invalid. Netscape Navigator sought to change that with the introduction of JavaScript. The capability to handle some basic validation on the client was an exciting new feature at a time when use of telephone modems was widespread. The associated slow speeds turned every trip to the server into an exercise in patience.

Since that time, JavaScript has grown into an important feature of every major web browser on the market. No longer bound to simple data validation, JavaScript now interacts with nearly all aspects of the browser window and its contents. JavaScript is recognized as a full programming language, capable of complex calculations and interactions, including closures, anonymous (lambda) functions, and even metaprogramming. JavaScript has become such an important part of the web that even alternative browsers, including those on mobile phones and those designed for users with disabilities, support it. Even Microsoft, with its own client-side scripting language called VBScript, ended up including its own JavaScript implementation in Internet Explorer from its earliest version.

The rise of JavaScript from a simple input validator to a powerful programming language could not have been predicted. JavaScript is at once a very simple and very complicated language that takes minutes to learn but years to master. To begin down the path to using JavaScript's full potential, it is important to understand its nature, history, and limitations.

A SHORT HISTORY

As the web gained popularity, a gradual demand for client-side scripting languages developed. At the time, most Internet users were connecting over a 28.8 kbps modem even though web pages were growing in size and complexity. Adding to users' pain was the large number of round-trips to the server required for simple form validation. Imagine filling out a form, clicking the Submit button, waiting 30 seconds for processing, and then being met with a message indicating that you forgot to complete a required field. Netscape, at that time on the cutting edge of technological innovation, began seriously considering the development of a client-side scripting language to handle simple processing.

In 1995, a Netscape developer named Brendan Eich began developing a scripting language called Mocha (later renamed as LiveScript) for the release of Netscape Navigator 2. The intention was to use it both in the browser and on the server, where it was to be called LiveWire.

Netscape entered into a development alliance with Sun Microsystems to complete the implementation of LiveScript in time for release. Just before Netscape Navigator 2 was officially released, Netscape changed LiveScript's name to JavaScript to capitalize on the buzz that Java was receiving from the press.

Because JavaScript 1.0 was such a hit, Netscape released version 1.1 in Netscape Navigator 3. The popularity of the fledgling web was reaching new heights, and Netscape had positioned itself to be the leading company in the market. At this time, Microsoft decided to put more resources into a competing browser named Internet Explorer. Shortly after Netscape Navigator 3 was released, Microsoft introduced Internet Explorer 3 with a JavaScript implementation called JScript (so called to avoid any possible licensing issues with Netscape). This major step for Microsoft into the realm of web browsers in August 1996 is now a date that lives in infamy for Netscape, but it also represented a major step forward in the development of JavaScript as a language.

Microsoft's implementation of JavaScript meant that there were two different JavaScript versions floating around: JavaScript in Netscape Navigator and JScript in Internet Explorer. Unlike C and many other programming languages, JavaScript had no standards governing its syntax or features, and the three different versions only highlighted this problem. With industry fears mounting, it was decided that the language must be standardized.

In 1997, JavaScript 1.1 was submitted to the European Computer Manufacturers Association (Ecma) as a proposal. Technical Committee #39 (TC39) was assigned to "standardize the syntax and semantics of a general purpose, cross-platform, vendor-neutral scripting language" (www.ecma-international.org/memento/TC39.htm). Made up of programmers from Netscape, Sun, Microsoft, Borland, NOMBAS, and other companies with interest in the future of scripting,

TC39 met for months to hammer out ECMA-262, a standard defining a new scripting language named ECMAScript (often pronounced as “ek-ma-script”).

The following year, the International Organization for Standardization and International Electrotechnical Commission (ISO/IEC) also adopted ECMAScript as a standard (ISO/IEC-16262). Since that time, browsers have tried, with varying degrees of success, to use ECMAScript as a basis for their JavaScript implementations.

JAVASCRIPT IMPLEMENTATIONS

Though JavaScript and ECMAScript are often used synonymously, JavaScript is much more than just what is defined in ECMA-262. Indeed, a complete JavaScript implementation is made up of the following three distinct parts (see Figure 1-1):

- The Core (ECMAScript)
- The Document Object Model (DOM)
- The Browser Object Model (BOM)

ECMAScript

ECMAScript, the language defined in ECMA-262, isn’t tied to web browsers. In fact, the language has no methods for input or output whatsoever. ECMA-262 defines this language as a base upon which more-robust scripting languages may be built. Web browsers are just one *host environment* in which an ECMAScript implementation may exist. A host environment provides the base implementation of ECMAScript and implementation extensions designed to interface with the environment itself. Extensions, such as the Document Object Model (DOM), use ECMAScript’s core types and syntax to provide additional functionality that’s more specific to the environment. Other host environments include NodeJS, a server-side JavaScript platform, and the increasingly obsolete Adobe Flash.

What exactly does ECMA-262 specify if it doesn’t reference web browsers? On a very basic level, it describes the following parts of the language:

- Syntax
- Types
- Statements
- Keywords
- Reserved words
- Operators
- Global objects

ECMAScript is simply a description of a language implementing all of the facets described in the specification. JavaScript implements ECMAScript, but so does Adobe ActionScript.

ECMAScript Editions

The different versions of ECMAScript are defined as *editions* (referring to the edition of ECMA-262 in which that particular implementation is described). The most recent edition of ECMA-262 is edition 7, released in 2016. The first edition of ECMA-262 was essentially the same as Netscape’s JavaScript 1.1 but with all references to browser-specific code removed and a few minor changes: ECMA-262 required support for the Unicode standard (to support multiple languages) and that objects be platform-independent (Netscape JavaScript 1.1 actually had different implementations of objects, such as the `Date` object, depending on the platform). This was a major reason why JavaScript 1.1 and 1.2 did not conform to the first edition of ECMA-262.

The second edition of ECMA-262 was largely editorial. The standard was updated to get into strict agreement with ISO/IEC-16262 and didn’t feature any additions, changes, or omissions. ECMAScript implementations typically don’t use the second edition as a measure of conformance.

The third edition of ECMA-262 was the first real update to the standard. It provided updates to string handling, the definition of errors, and numeric outputs. It also added support for regular expressions, new control statements, `try-catch` exception handling, and small changes to better prepare the standard for internationalization. To many, this marked the arrival of ECMAScript as a true programming language.

The fourth edition of ECMA-262 was a complete overhaul of the language. In response to the popularity of JavaScript on the web, developers began revising ECMAScript to meet the growing demands of web development around the world. In response, Ecma TC39 reconvened to decide the future of the language. The resulting specification defined an almost completely new language based on the third edition. The fourth edition includes strongly typed variables, new statements and data structures, true classes and classical inheritance, and new ways to interact with data.

As an alternate proposal, a specification called “ECMAScript 3.1,” was developed as a smaller evolution of the language by a subcommittee of TC39, who believed that the fourth edition was too big of a jump for the language. The result was a smaller proposal with incremental changes to ECMAScript that could be implemented on top of existing JavaScript engines. Ultimately, the ES3.1 subcommittee won over support from TC39, and the fourth edition of ECMA-262 was abandoned before officially being published.

ECMAScript 3.1 became ECMA-262, fifth edition, and was officially published on December 3, 2009. The fifth edition sought to clarify perceived ambiguities of the third edition and introduce additional functionality. The new functionality includes a native `JSON` object for parsing and serializing JSON data, methods for inheritance and advanced property definition, and the inclusion of a new strict mode that slightly augments how ECMAScript engines interpret and execute code. The fifth edition saw a maintenance revision in June 2011; this was merely for corrections in the specification and introduced no new language or library features.

The sixth edition of ECMA-262—colloquially referred to as ES6, ES2015, or ES Harmony—was published in June 2015, and contains arguably the most important collection of enhancements to the specification since its inception. ES6 adds formal support for classes, modules, iterators, generators, arrow functions, promises, reflection, proxies, and a host of new data types.

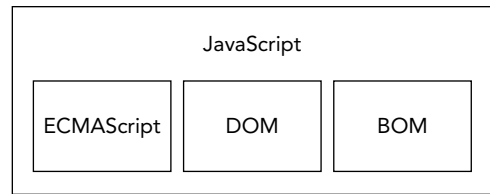

FIGURE 1-1

The seventh edition of ECMA-262, dubbed ES7 or ES2016, was published in June of 2016. This revision included only a handful of syntactical additions such as `Array.prototype.includes` and the exponentiation operator.

The eighth edition of ECMA-262, called ES8 or ES2017, was finalized in January of 2017. This revision included asynchronous iteration, rest and spread properties, a collection of new regular expression features, a `Promise finally()` catchall handler, and template literal revisions.

The ninth edition of ECMA-262 is still being finalized, but it already has a large number of features in stage 3. Its most significant addition will likely be dynamic importing of ES6 modules.

What Does ECMAScript Conformance Mean?

ECMA-262 lays out the definition of ECMAScript conformance. To be considered an implementation of ECMAScript, an implementation must do the following:

- Support all "types, values, objects, properties, functions, and program syntax and semantics" as they are described in ECMA-262.
- Support the Unicode character standard.

Additionally, a conforming implementation may do the following:

- Add "additional types, values, objects, properties, and functions" that are not specified in ECMA-262. ECMA-262 describes these additions as primarily new objects or new properties of objects not given in the specification.
- Support "program and regular expression syntax" that is not defined in ECMA-262 (meaning that the built-in regular-expression support is allowed to be altered and extended).

These criteria give implementation developers a great amount of power and flexibility for developing new languages based on ECMAScript, which partly accounts for its popularity.

ECMAScript Support in Web Browsers

Netscape Navigator 3 shipped with JavaScript 1.1 in 1996. That same JavaScript 1.1 specification was then submitted to Ecma as a proposal for the new standard, ECMA-262. With JavaScript's explosive popularity, Netscape was very happy to start developing version 1.2. There was, however, one problem: Ecma hadn't yet accepted Netscape's proposal.

Shortly after Netscape Navigator 3 was released, Microsoft introduced Internet Explorer 3. This version of IE shipped with JScript 1.0, which was supposed to be equivalent to JavaScript 1.1. However, because of undocumented and improperly replicated features, JScript 1.0 fell far short of JavaScript 1.1.

Netscape Navigator 4 was shipped in 1997 with JavaScript 1.2 before the first edition of ECMA-262 was accepted and standardized later that year. As a result, JavaScript 1.2 is not compliant with the first edition of ECMAScript even though ECMAScript was supposed to be based on JavaScript 1.1.

The next update to JScript occurred in Internet Explorer 4 with JScript version 3.0 (version 2.0 was released in Microsoft Internet Information Server version 3.0 but was never included in a browser). Microsoft put out a press release touting JScript 3.0 as the first truly Ecma-compliant scripting

language in the world. At that time, ECMA-262 hadn't yet been finalized, so JScript 3.0 suffered the same fate as JavaScript 1.2: it did not comply with the final ECMAScript standard.

Netscape opted to update its JavaScript implementation in Netscape Navigator 4.06 to JavaScript 1.3, which brought Netscape into full compliance with the first edition of ECMA-262. Netscape added support for the Unicode standard and made all objects platform-independent while keeping the features that were introduced in JavaScript 1.2.

When Netscape released its source code to the public as the Mozilla project, it was anticipated that JavaScript 1.4 would be shipped with Netscape Navigator 5. However, a radical decision to completely redesign the Netscape code from the bottom up derailed that effort. JavaScript 1.4 was released only as a server-side language for Netscape Enterprise Server and never made it into a web browser.

By 2008, the five major web browsers (Internet Explorer, Firefox, Safari, Chrome, and Opera) all complied with the third edition of ECMA-262. Internet Explorer 8 was the first to start implementing the fifth edition of ECMA-262 specification and delivered complete support in Internet Explorer 9. Firefox 4 soon followed suit. The following table lists ECMAScript support in the most popular web browsers.

BROWSER	ECMAScript COMPLIANCE
Netscape Navigator 2	—
Netscape Navigator 3	—
Netscape Navigator 4–4.05	—
Netscape Navigator 4.06–4.79	Edition 1
Netscape 6+ (Mozilla 0.6.0+)	Edition 3
Internet Explorer 3	—
Internet Explorer 4	—
Internet Explorer 5	Edition 1
Internet Explorer 5.5–8	Edition 3
Internet Explorer 9	Edition 5*
Internet Explorer 10–11	Edition 5
Edge 12+	Edition 6
Opera 6–7.1	Edition 2
Opera 7.2+	Edition 3
Opera 15–28	Edition 5
Opera 29–35	Edition 6*
Opera 36+	Edition 6

BROWSER	ECMASCRIPT COMPLIANCE
Safari 1–2.0.x	Edition 3*
Safari 3.1–5.1	Edition 5*
Safari 6–8	Edition 5
Safari 9+	Edition 6
iOS Safari 3.2–5.1	Edition 5*
iOS Safari 6–8.4	Edition 5
iOS Safari 9.2+	Edition 6
Chrome 1–3	Edition 3
Chrome 4–22	Edition 5*
Chrome 23+	Edition 5
Chrome 42–48	Edition 6*
Chrome 49+	Edition 6
Firefox 1–2	Edition 3
Firefox 3.0.x–20	Edition 5*
Firefox 21–44	Edition 5
Firefox 45+	Edition 6

*Incomplete implementations

The Document Object Model

The *Document Object Model* (DOM) is an application programming interface (API) for XML that was extended for use in HTML. The DOM maps out an entire page as a hierarchy of nodes. Each part of an HTML or XML page is a type of node containing different kinds of data. Consider the following HTML page:

```
<html>
  <head>
    <title>Sample Page</title>
  </head>
  <body>
    <p> Hello World!</p>
  </body>
</html>
```

This code can be diagrammed into a hierarchy of nodes using the DOM (see Figure 1-2).

By creating a tree to represent a document, the DOM allows developers an unprecedented level of control over its content and structure. Nodes can be removed, added, replaced, and modified easily by using the DOM API.

Why the DOM Is Necessary

With Internet Explorer 4 and Netscape Navigator 4 each supporting different forms of Dynamic HTML (DHTML), developers for the first time could alter the appearance and content of a web page without reloading it. This represented a tremendous step forward in web technology but also a huge problem. Netscape and Microsoft went separate ways in developing DHTML, thus ending the period when developers could write a single HTML page that could be accessed by any web browser.

It was decided that something had to be done to preserve the cross-platform nature of the web. The fear was that if someone didn't rein in Netscape and Microsoft, the web would develop into two distinct factions that were exclusive to targeted browsers. It was then that the World Wide Web Consortium (W3C), the body charged with creating standards for web communication, began working on the DOM.

DOM Levels

DOM Level 1 became a W3C recommendation in October 1998. It consisted of two modules: the DOM Core, which provided a way to map the structure of an XML-based document to allow for easy access to and manipulation of any part of a document, and the DOM HTML, which extended the DOM Core by adding HTML-specific objects and methods.

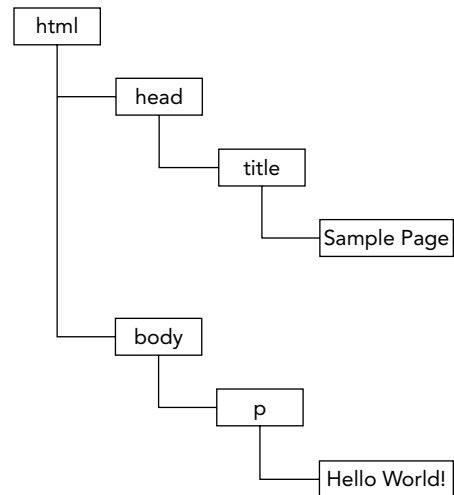

FIGURE 1-2

NOTE *Note that the DOM is not JavaScript-specific and indeed has been implemented in numerous other languages. For web browsers, however, the DOM has been implemented using ECMAScript and now makes up a large part of the JavaScript language.*

Whereas the goal of DOM Level 1 was to map out the structure of a document, the aims of DOM Level 2 were much broader. This extension of the original DOM added support for mouse and user-interface events (long supported by DHTML), ranges, and traversals (methods to iterate over a DOM document), and support for Cascading Style Sheets (CSS) through object interfaces. The original DOM Core introduced in Level 1 was also extended to include support for XML namespaces.

DOM Level 2 introduced the following new modules of the DOM to deal with new types of interfaces:

- **DOM views**—Describes interfaces to keep track of the various views of a document (the document before and after CSS styling, for example)

- **DOM events**—Describes interfaces for events and event handling
- **DOM style**—Describes interfaces to deal with CSS-based styling of elements
- **DOM traversal and range**—Describes interfaces to traverse and manipulate a document tree

DOM Level 3 further extends the DOM with the introduction of methods to load and save documents in a uniform way (contained in a new module called DOM Load and Save) and methods to validate a document (DOM Validation). In Level 3, the DOM Core is extended to support all of XML 1.0, including XML Infoset, XPath, and XML Base.

Presently, the W3C no longer maintains the DOM as a set of levels, but rather as the DOM Living Standard, snapshots of which are termed DOM4. Among its introductions is the addition of Mutation Observers to replace Mutation Events.

NOTE *When reading about the DOM, you may come across references to DOM Level 0. Note that there is no standard called DOM Level 0; it is simply a reference point in the history of the DOM. DOM Level 0 is considered to be the original DHTML supported in Internet Explorer 4.0 and Netscape Navigator 4.0.*

Other DOMs

Aside from the DOM Core and DOM HTML interfaces, several other languages have had their own DOM standards published. The languages in the following list are XML-based, and each DOM adds methods and interfaces unique to a particular language:

- Scalable Vector Graphics (SVG) 1.0
- Mathematical Markup Language (MathML) 1.0
- Synchronized Multimedia Integration Language (SMIL)

Additionally, other languages have developed their own DOM implementations, such as Mozilla's XML User Interface Language (XUL). However, only the languages in the preceding list are standard recommendations from W3C.

DOM Support in Web Browsers

The DOM had been a standard for some time before web browsers started implementing it. Internet Explorer made its first attempt with version 5, but it didn't have any realistic DOM support until version 5.5, when it implemented most of DOM Level 1. Internet Explorer didn't introduce new DOM functionality in versions 6 and 7, though version 8 introduced some bug fixes.

For Netscape, no DOM support existed until Netscape 6 (Mozilla 0.6.0) was introduced. After Netscape 7, Mozilla switched its development efforts to the Firefox browser. Firefox 3+ supports all of Level 1, nearly all of Level 2, and some parts of Level 3. (The goal of the Mozilla development team was to build a 100 percent standards-compliant browser, and their work paid off.)

DOM support became a huge priority for most browser vendors, and efforts have been ongoing to improve support with each release. The following table shows DOM support for popular browsers.

BROWSER	DOM COMPLIANCE
Netscape Navigator 1.–4.x	—
Netscape 6+ (Mozilla 0.6.0+)	Level 1, Level 2 (almost all), Level 3 (partial)
Internet Explorer 2–4.x	—
Internet Explorer 5	Level 1 (minimal)
Internet Explorer 5.5–8	Level 1 (almost all)
Internet Explorer 9+	Level 1, Level 2, Level 3
Edge	Level 1, Level 2, Level 3
Opera 1–6	—
Opera 7–8.x	Level 1 (almost all), Level 2 (partial)
Opera 9–9.9	Level 1, Level 2 (almost all), Level 3 (partial)
Opera 10+	Level 1, Level 2, Level 3 (partial)
Safari 1.0.x	Level 1
Safari 2+	Level 1, Level 2 (partial), Level 3 (partial)
iOS Safari 3.2+	Level 1, Level 2 (partial), Level 3 (partial)
Chrome 1+	Level 1, Level 2 (partial), Level 3 (partial)
Firefox 1+	Level 1, Level 2 (almost all), Level 3 (partial)

NOTE *The content of this compatibility table is changing all the time and should only be used as a historical reference.*

The Browser Object Model

The Internet Explorer 3 and Netscape Navigator 3 browsers featured a *Browser Object Model* (BOM) that allowed access and manipulation of the browser window. Using the BOM, developers can interact with the browser outside of the context of its displayed page. What made the BOM truly unique, and often problematic, was that it was the only part of a JavaScript implementation that had no related standard. This changed with the introduction of HTML5, which sought to codify much of the BOM as part of a formal specification. Thanks to HTML5, a lot of the confusion surrounding the BOM has dissipated.

Primarily, the BOM deals with the browser window and frames, but generally any browser-specific extension to JavaScript is considered to be a part of the BOM. The following are some such extensions:

- The capability to pop up new browser windows
- The capability to move, resize, and close browser windows
- The `navigator` object, which provides detailed information about the browser
- The `location` object, which gives detailed information about the page loaded in the browser
- The `screen` object, which gives detailed information about the user's screen resolution
- The `performance` object, which gives detailed information about the browser's memory consumption, navigational behavior, and timing statistics
- Support for cookies
- Custom objects such as `XMLHttpRequest` and Internet Explorer's `ActiveXObject`

Because no standards existed for the BOM for a long time, each browser has its own implementation. There are some *de facto* standards, such as having a `window` object and a `navigator` object, but each browser defines its own properties and methods for these and other objects. With HTML5 now available, the implementation details of the BOM are expected to grow in a much more compatible way. A detailed discussion of the BOM is included in the chapter “Browser Object Model.”

JAVASCRIPT VERSIONS

Mozilla, as a descendant from the original Netscape, is the only browser vendor that has continued the original JavaScript version-numbering sequence. When the Netscape source code was spun off into an open-source project (named the Mozilla Project), the last browser version of JavaScript was 1.3. (As mentioned previously, version 1.4 was implemented on the server exclusively.) As the Mozilla Foundation continued work on JavaScript, adding new features, keywords, and syntaxes, the JavaScript version number was incremented. The following table shows the JavaScript version progression in Netscape/Mozilla browsers.

BROWSER	JAVASCRIPT VERSION
Netscape Navigator 2	1.0
Netscape Navigator 3	1.1
Netscape Navigator 4	1.2
Netscape Navigator 4.06	1.3
Netscape 6+ (Mozilla 0.6.0+)	1.5
Firefox 1	1.5
Firefox 1.5	1.6

BROWSER	JAVASCRIPT VERSION
Firefox 2	1.7
Firefox 3	1.8
Firefox 3.5	1.8.1
Firefox 3.6	1.8.2
Firefox 4	1.8.5

The numbering scheme was based on the idea that Firefox 4 would feature JavaScript 2.0, and each increment in the version number prior to that point indicates how close the JavaScript implementation is to the 2.0 proposal. Though this was the original plan, the evolution of JavaScript happened in such a way that this was no longer possible. There is currently no target implementation for JavaScript 2.0, and this style of versioning ceased past the Firefox 4 release.

NOTE *It's important to note that only the Netscape/Mozilla browsers followed this versioning scheme. Internet Explorer, for example, has different version numbers for JScript. These JScript versions don't correspond whatsoever to the JavaScript versions mentioned in the preceding table. Furthermore, most browsers talk about JavaScript support in relation to their level of ECMAScript compliance and DOM support.*

SUMMARY

JavaScript is a scripting language designed to interact with web pages and is made up of the following three distinct parts:

- ECMAScript, which is defined in ECMA-262 and provides the core functionality
- The Document Object Model (DOM), which provides methods and interfaces for working with the content of a web page
- The Browser Object Model (BOM), which provides methods and interfaces for interacting with the browser

There are varying levels of support for the three parts of JavaScript across the five major web browsers (Internet Explorer, Firefox, Chrome, Safari, and Opera). Support for ECMAScript 5 is generally good across all browsers, and support for ECMAScript 6 and 7 is growing. Support for the DOM varies, but Level 3 compliance is increasingly normative. The BOM, codified in HTML5, can vary from browser to browser, though there are some commonalities that are assumed to be available.

2

JavaScript in HTML

WHAT'S IN THIS CHAPTER?

- Using the `<script>` element
- Comparing inline and external scripts
- Examining how document modes affect JavaScript
- Preparing for JavaScript-disabled experiences

The introduction of JavaScript into web pages immediately ran into the web's predominant language, HTML. As part of its original work on JavaScript, Netscape tried to figure out how to make JavaScript coexist in HTML pages without breaking those pages' rendering in other browsers. Through trial, error, and controversy, several decisions were finally made and agreed upon to bring universal scripting support to the web. Much of the work done in these early days of the web has survived and become formalized in the HTML specification.

THE `<SCRIPT>` ELEMENT

The primary method of inserting JavaScript into an HTML page is via the `<script>` element. This element was created by Netscape and first implemented in Netscape Navigator 2. It was later added to the formal HTML specification. There are six attributes for the `<script>` element:

- `async`—Optional. Indicates that the script should begin downloading immediately but should not prevent other actions on the page such as downloading resources or waiting for other scripts to load. Valid only for external script files.
- `charset`—Optional. The character set of the code specified using the `src` attribute. This attribute is rarely used because most browsers don't honor its value.
- `crossorigin`—Optional. Configures the CORS settings for the associated request; by default, CORS is not used at all. `crossorigin="anonymous"` will configure the request for the file to not have the credentials flag set. `crossorigin="use-credentials"` will set the credentials flag, meaning the outgoing request will include credentials.

- `defer`—Optional. Indicates that the execution of the script can safely be deferred until after the document's content has been completely parsed and displayed. Valid only for external scripts. Internet Explorer 7 and earlier also allow for inline scripts.
- `integrity`—Optional. Allows for verification of Subresource Integrity (SRI) by checking the retrieved resource against a provided cryptographic signature. If the signature of the retrieved resource does not match that specified by this attribute, the page will error and the script will not execute. This is useful for ensuring that a Content Delivery Network (CDN) is not serving malicious payloads.
- `language`—Deprecated. Originally indicated the scripting language being used by the code block (such as "JavaScript", "JavaScript1.2", or "VBScript"). Most browsers ignore this attribute; it should not be used.
- `src`—Optional. Indicates an external file that contains code to be executed.
- `type`—Optional. Replaces `language`; indicates the content type (also called MIME type) of the scripting language being used by the code block. Traditionally, this value has always been "text/javascript", though both "text/javascript" and "text/ecmascript" are deprecated. JavaScript files are typically served with the "application/x-javascript" MIME type even though setting this in the `type` attribute may cause the script to be ignored. Other values that work in non-Internet Explorer browsers are "application/javascript" and "application/ecmascript". If the value is `module`, the code is treated as an ES6 module and only then is eligible to use the `import` and `export` keywords.

There are two ways to use the `<script>` element: embed JavaScript code directly into the page or include JavaScript from an external file.

To include inline JavaScript code, place JavaScript code inside the `<script>` element directly, as follows:

```
<script>
  function sayHi() {
    console.log("Hi!");
  }
</script>
```

The JavaScript code contained inside a `<script>` element is interpreted from top to bottom. In the case of this example, a function definition is interpreted and stored inside the interpreter environment. The rest of the page content is not loaded and/or displayed until after all of the code inside the `<script>` element has been evaluated.

When using inline JavaScript code, keep in mind that you cannot have the string `"</script>"` anywhere in your code. For example, the following code causes an error when loaded into a browser:

```
<script>
  function sayScript() {
    console.log("</script>");
  }
</script>
```

Because of the way that inline scripts are parsed, the browser sees the string `"</script>"` as if it were the closing `</script>` tag. This problem can be avoided easily by escaping the `"/"` character, as

in this example:

```
<script>
  function sayScript() {
    console.log("</script>");
  }
</script>
```

The changes to this code make it acceptable to browsers and won't cause any errors.

To include JavaScript from an external file, the `src` attribute is required. The value of `src` is a URL linked to a file containing JavaScript code, like this:

```
<script src="example.js"></script>
```

In this example, an external file named `example.js` is loaded into the page. The file itself need only contain the JavaScript code that would occur between the opening `<script>` and closing `</script>` tags. As with inline JavaScript code, processing of the page is halted while the external file is interpreted. (There is also some time taken to download the file.) In XHTML documents, you can omit the closing tag, as in this example:

```
<script src="example.js"/>
```

This syntax should not be used in HTML documents because it is invalid HTML and won't be handled properly by some browsers, most notably Internet Explorer.

NOTE *By convention, external JavaScript files have a .js extension. This is not a requirement because browsers do not check the file extension of included JavaScript files. This leaves open the possibility of dynamically generating JavaScript code using a server-side scripting language, or for in-browser transpilation into JavaScript from a JavaScript extension language such as TypeScript or React's JSX. Keep in mind, though, that servers often use the file extension to determine the correct MIME type to apply to the response. If you don't use a .js extension, double-check that your server is returning the correct MIME type.*

It's important to note that a `<script>` element using the `src` attribute should not include additional JavaScript code between the `<script>` and `</script>` tags. If both are provided, the script file is downloaded and executed while the inline code is ignored.

One of the most powerful and most controversial parts of the `<script>` element is its ability to include JavaScript files from outside domains. Much like an `` element, the `<script>` element's `src` attribute may be set to a full URL that exists outside the domain on which the HTML page exists, as in this example:

```
<script src="http://www.somewhere.com/afile.js"></script>
```

When the browser goes to resolve this resource, it will send a `GET` request to the path specified in the `src` attribute to retrieve the resource—presumably a JavaScript file. This initial request is not subject to the browser's cross-origin restrictions, but any JavaScript returned and executed will be. Of course, this request is still subject to the HTTP/HTTPS protocol of the parent page.

Code from an external domain will be loaded and interpreted as if it were part of the page that is loading it. This capability allows you to serve up JavaScript from various domains, if necessary. Be careful, however, if you are referencing JavaScript files located on a server that you don't control. A malicious programmer could, at any time, replace the file. When including JavaScript files from a different domain, make sure you are the domain owner or the domain is owned by a trusted source. The `<script>` tag's `integrity` attribute gives you a tool to defend against this; however, it has limited browser support.

Regardless of how the code is included, the `<script>` elements are interpreted in the order in which they appear in the page so long as the `defer` and `async` attributes are not present. The first `<script>` element's code must be completely interpreted before the second `<script>` element begins interpretation, the second must be completed before the third, and so on.

Tag Placement

Traditionally, all `<script>` elements were placed within the `<head>` element on a page, as in this example:

```
<!DOCTYPE html>
<html>
  <head>
    <title>Example HTML Page</title>
    <script src="example1.js"></script>
    <script src="example2.js"></script>
  </head>
  <body>
    <!-- content here -->
  </body>
</html>
```

The main purpose of this format was to keep external file references, both CSS files and JavaScript files, in the same area. However, including all JavaScript files in the `<head>` of a document means that all of the JavaScript code must be downloaded, parsed, and interpreted before the page begins rendering (rendering begins when the browser receives the opening `<body>` tag). For pages that require a lot of JavaScript code, this can cause a noticeable delay in page rendering, during which time the browser will be completely blank. For this reason, modern web applications typically include all JavaScript references in the `<body>` element, after the page content, as shown in this example:

```
<!DOCTYPE html>
<html>
  <head>
    <title>Example HTML Page</title>
  </head>
  <body>
    <!-- content here -->
    <script src="example1.js"></script>
    <script src="example2.js"></script>
  </body>
</html>
```

Using this approach, the page is completely rendered in the browser before the JavaScript code is processed. The resulting user experience is perceived as faster because the amount of time spent on a blank browser window is reduced.

Deferred Scripts

HTML 4.01 defines an attribute named `defer` for the `<script>` element. The purpose of `defer` is to indicate that a script won't be changing the structure of the page as it executes. As such, the script can be run safely after the entire page has been parsed. Setting the `defer` attribute on a `<script>` element signals to the browser that download should begin immediately but execution should be deferred:

```
<!DOCTYPE html>
<html>
  <head>
    <title>Example HTML Page</title>
    <script defer src="example1.js"></script>
    <script defer src="example2.js"></script>
  </head>
  <body>
    <!-- content here -->
  </body>
</html>
```

Even though the `<script>` elements in this example are included in the document `<head>`, they will not be executed until after the browser has received the closing `</html>` tag. The HTML5 specification indicates that scripts will be executed in the order in which they appear, so the first deferred script executes before the second deferred script, and both will execute before the `DOMContentLoaded` event (see the chapter “Events” for more information). In reality, though, deferred scripts don't always execute in order or before the `DOMContentLoaded` event, so it's best to include just one when possible.

As mentioned previously, the `defer` attribute is supported only for external script files. This was a clarification made in HTML5, so browsers that support the HTML5 implementation will ignore `defer` when set on an inline script. Internet Explorer 4–7 all exhibit the old behavior, while Internet Explorer 8 and above support the HTML5 behavior.

Support for the `defer` attribute was added beginning with Internet Explorer 4, Firefox 3.5, Safari 5, and Chrome 7. All other browsers simply ignore this attribute and treat the script as it normally would. For this reason, it's still best to put deferred scripts at the bottom of the page.

NOTE For XHTML documents, specify the `defer` attribute as `defer="defer"`.

Asynchronous Scripts

HTML5 introduces the `async` attribute for `<script>` elements. The `async` attribute is similar to `defer` in that it changes the way the script is processed. Also similar to `defer`, `async` applies only to external scripts and signals the browser to begin downloading the file immediately. Unlike `defer`, scripts marked as `async` are not guaranteed to execute in the order in which they are specified.

For example:

```
<!DOCTYPE html>
<html>
  <head>
```



```

<title>Example HTML Page</title>
<script async src="example1.js"></script>
<script async src="example2.js"></script>
</head>
<body>
<!-- content here -->
</body>
</html>

```

In this code, the second script file might execute before the first, so it's important that there are no dependencies between the two. The purpose of specifying an `async` script is to indicate that the page need not wait for the script to be downloaded and executed before continuing to load, and it also need not wait for another script to load and execute before it can do the same. Because of this, it's recommended that asynchronous scripts not modify the DOM as they are loading.

Asynchronous scripts are guaranteed to execute before the page's `load` event and may execute before or after `DOMContentLoaded` (see the “Events” chapter for details). Firefox 3.6, Safari 5, and Chrome 7 support asynchronous scripts. Using `async` scripts also confers to your page the implicit assumption that you do not intend to use `document.write`—but good web development practices dictate that you shouldn't be using it anyway.

NOTE For XHTML documents, specify the `async` attribute as `async="async"`.

Dynamic Script Loading

You are not limited to using static `<script>` tags to retrieve resources. Because JavaScript is able to use the DOM API, you are more than welcome to add script elements, which will, in turn, load the resources they specify. This can be done by creating script elements and attaching them to the DOM:

```

let script = document.createElement('script');
script.src = 'gibberish.js';
document.head.appendChild(script);

```

Of course, this request will not be generated until the `HTMLElement` is attached to the DOM, and therefore not until this script itself runs. By default, scripts that are created in this fashion are `async`. This can be problematic, however, as all browsers support `createElement` but not all support `async` script requests. Therefore, to unify the dynamic script loading behavior, you can explicitly mark the tag as synchronous:

```

let script = document.createElement('script');
script.src = 'gibberish.js';
script.async = false;
document.head.appendChild(script);

```

Resources fetched in this fashion will be hidden from browser preloaders. This will severely injure their priority in the resource fetching queue. Depending on how your application works and how it is used, this can severely damage performance. To inform preloaders of the existence of these dynamically requested files, you can explicitly declare them in the document head:

```

<link rel="subresource" href="gibberish.js">

```

Changes in XHTML

Extensible HyperText Markup Language, or XHTML, is a reformulation of HTML as an application of XML. Unlike in HTML, where the `type` attribute is unneeded when using JavaScript, in XHTML, the `<script>` element requires that you specify the `type` attribute as `text/javascript`.

The rules for writing code in XHTML are stricter than those for HTML, which affects the `<script>` element when using embedded JavaScript code. Although valid in HTML, the following code block is invalid in XHTML:

```
<script type="text/javascript">
function compare(a, b) {
  if (a < b) {
    console.log("A is less than B");
  } else if (a > b) {
    console.log("A is greater than B");
  } else {
    console.log("A is equal to B");
  }
}
</script>
```

In HTML, the `<script>` element has special rules governing how its contents should be parsed; in XHTML, these special rules don't apply. This means that the less-than symbol (`<`) in the statement `a < b` is interpreted as the beginning of a tag, which causes a syntax error because a less-than symbol must not be followed by a space.

There are two options for fixing the XHTML syntax error. The first is to replace all occurrences of the less-than symbol (`<`) with its HTML entity (`<`). The resulting code looks like this:

```
<script type="text/javascript">
function compare(a, b) {
  if (a &lt; b) {
    console.log("A is less than B");
  } else if (a > b) {
    console.log("A is greater than B");
  } else {
    console.log("A is equal to B");
  }
}
</script>
```

This code will now run in an XHTML page; however, the code is slightly less readable. Fortunately, there is another approach.

The second option for turning this code into a valid XHTML version is to wrap the JavaScript code in a CDATA section. In XHTML (and XML), CDATA sections are used to indicate areas of the document that contain free-form text not intended to be parsed. This enables you to use any character, including the less-than symbol, without incurring a syntax error. The format is as follows:

```
<script type="text/javascript"><![CDATA[
function compare(a, b) {
  if (a < b) {
    console.log("A is less than B");
```

```

    } else if (a > b) {
      console.log("A is greater than B");
    } else {
      console.log("A is equal to B");
    }
  }
}

```

In XHTML-compliant web browsers, this solves the problem. However, many browsers are still not XHTML-compliant and don't support the CDATA section. To work around this, the CDATA markup must be offset by JavaScript comments:

```

<script type="text/javascript">
//<![CDATA[
  function compare(a, b) {
    if (a < b) {
      console.log("A is less than B");
    } else if (a > b) {
      console.log("A is greater than B");
    } else {
      console.log("A is equal to B");
    }
  }
}
//]]>
</script>

```

This format works in all modern browsers. Though a little bit of a hack, it validates as XHTML and degrades gracefully for pre-XHTML browsers.

NOTE *XHTML mode is triggered when a page specifies its MIME type as "application/xhtml+xml". Not all browsers officially support XHTML served in this manner.*

Deprecated Syntax

Since Netscape 2 was released in 1995, all browsers have used JavaScript as their default programming language. The `type` attribute uses a MIME type string to identify the contents of `<script>`, but MIME types are not standardized across browsers. Even though browsers default to JavaScript, in some cases an invalid or unrecognized MIME type value for the `type` attribute will cause some browsers to skip execution of the associated code. Therefore, unless you are using XHTML or the `<script>` tag requests or wraps non-JavaScript, the best practice is to not specify a `type` attribute at all.

When the `<script>` element was originally introduced, it marked a departure from traditional HTML parsing. Special rules needed to be applied within this element, and that caused problems for browsers that didn't support JavaScript (the most notable being Mosaic). Nonsupporting browsers would output the contents of the `<script>` element onto the page, effectively ruining the page's appearance.

Netscape worked with Mosaic to come up with a solution that would hide embedded JavaScript code from browsers that didn't support it. The final solution was to enclose the script code in an HTML comment, like this:

```
<script><!--
  function sayHi () {
    console.log("Hi!");
  }
//--></script>
```

Using this format, browsers like Mosaic would safely ignore the content inside of the `<script>` tag, and browsers that supported JavaScript had to look for this pattern to recognize that there was indeed JavaScript content to be parsed.

Although this format is still recognized and interpreted correctly by all web browsers, it is no longer necessary and should not be used. In XHTML mode, this also causes the script to be ignored because it is inside a valid XML comment.

INLINE CODE VERSUS EXTERNAL FILES

Although it's possible to embed JavaScript in HTML files directly, it's generally considered a best practice to include as much JavaScript as possible using external files. Keeping in mind that there are no hard and fast rules regarding this practice, the arguments for using external files are as follows:

- **Maintainability**—JavaScript code that is sprinkled throughout various HTML pages turns code maintenance into a problem. It is much easier to have a directory for all JavaScript files so that developers can edit JavaScript code independent of the markup in which it's used.
- **Caching**—Browsers cache all externally linked JavaScript files according to specific settings, meaning that if two pages are using the same file, the file is downloaded only once. This ultimately means faster page-load times.
- **Future-proof**—By including JavaScript using external files, there's no need to use the XHTML or comment hacks mentioned previously. The syntax to include external files is the same for both HTML and XHTML.

One notable consideration when configuring how external files are requested is their implication on request bandwidth. With SPDY/HTTP2, the per-request overhead is substantially reduced insofar as it may be advantageous to deliver scripts to the client as lightweight independent JavaScript components.

For example, your first page might have the following:

```
<script src="mainA.js"></script>
<script src="component1.js"></script>
<script src="component2.js"></script>
<script src="component3.js"></script>
...
```

A subsequent page loaded might have the following:

```
<script src="mainB.js"></script>
<script src="component3.js"></script>
```

```
<script src="component4.js"></script>
<script src="component5.js"></script>
...
```

On the initial request, if the browser supports SPDY/HTTP2, it will be able to efficiently retrieve a number of files from the same endpoint, and it will enter them into the browser cache on a per-file basis. From the perspective of the browser, retrieval of these individual resources over SPDY/HTTP2 should have approximately the same latency as delivering a monolithic JavaScript payload.

On the second page request, because you segmented your application into lightweight cacheable files, some of the components that the second page also depends upon are already in the browser cache.

Of course, this assumes the browser supports SPDY/HTTP2, which is only a valid assumption for modern browsers. Monolithic payloads may be more appropriate if your aim is to include support for older browsers.

DOCUMENT MODES

Internet Explorer 5.5 introduced the concept of document modes through the use of doctype switching. The first two document modes were *quirks mode*, which made Internet Explorer behave as if it were version 5 (with several nonstandard features) and *standards mode*, which made Internet Explorer behave in a more standards-compliant way. Though the primary difference between these two modes is related to the rendering of content with regard to CSS, there are also several side effects related to JavaScript. These side effects are discussed throughout the book.

Since Internet Explorer first introduced the concept of document modes, other browsers have followed suit. As this adoption happened, a third mode called *almost standards mode* arose. That mode has a lot of the features of standards mode but isn't as strict. The main difference is in the treatment of spacing around images (most noticeable when images are used in tables).

Quirks mode is achieved in all browsers by omitting the doctype at the beginning of the document. This is considered poor practice because quirks mode is very different across all browsers, and no level of true browser consistency can be achieved without hacks.

Standards mode is turned on when one of the following doctypes is used:

```
<!-- HTML 4.01 Strict -->
<!DOCTYPE HTML PUBLIC "-//W3C//DTD HTML 4.01//EN"
"http://www.w3.org/TR/html4/strict.dtd">

<!-- XHTML 1.0 Strict -->
<!DOCTYPE html PUBLIC
"-//W3C//DTD XHTML 1.0 Strict//EN"
"http://www.w3.org/TR/xhtml1/DTD/xhtml1-strict.dtd">
<!-- HTML5 -->
<!DOCTYPE html>
```

Almost standards mode is triggered by transitional and frameset doctypes, as follows:

```
<!-- HTML 4.01 Transitional -->
<!DOCTYPE HTML PUBLIC
"-//W3C//DTD HTML 4.01 Transitional//EN"
"http://www.w3.org/TR/html4/loose.dtd">
```

```

<!-- HTML 4.01 Frameset -->
<!DOCTYPE HTML PUBLIC
"-//W3C//DTD HTML 4.01 Frameset//EN"
"http://www.w3.org/TR/html4/frameset.dtd">

<!-- XHTML 1.0 Transitional -->
<!DOCTYPE html PUBLIC
"-//W3C//DTD XHTML 1.0 Transitional//EN"
"http://www.w3.org/TR/xhtml1/DTD/xhtml1-transitional.dtd">

<!-- XHTML 1.0 Frameset -->
<!DOCTYPE html PUBLIC
"-//W3C//DTD XHTML 1.0 Frameset//EN"
"http://www.w3.org/TR/xhtml1/DTD/xhtml1-frameset.dtd">

```

Because almost standards mode is so close to standards mode, the distinction is rarely made. People talking about “standards mode” may be talking about either, and detection for the document mode (discussed later in this book) also doesn’t make the distinction. Throughout this book, the term *standards mode* should be taken to mean any mode other than quirks.

THE <NOSCRIPT> ELEMENT

Of particular concern to early browsers was the graceful degradation of pages when the browser didn’t support JavaScript. To that end, the <noscript> element was created to provide alternate content for browsers without JavaScript. Although effectively 100% of browsers now support JavaScript, this element is still useful for browsers that explicitly disable JavaScript.

The <noscript> element can contain any HTML elements, aside from <script>, that can be included in the document <body>. Any content contained in a <noscript> element will be displayed under only the following two circumstances:

- The browser doesn’t support scripting.
- The browser’s scripting support is turned off.

If either of these conditions is met, then the content inside the <noscript> element is rendered. In all other cases, the browser does not render the content of <noscript>.

Here is a simple example:

```

<!DOCTYPE html>
<html>
  <head>
    <title>Example HTML Page</title>
    <script "defer="defer" src="example1.js"></script>
    <script "defer="defer" src="example2.js"></script>
  </head>
  <body>
    <noscript>
      <p>This page requires a JavaScript-enabled browser.</p>
    </noscript>
  </body>
</html>

```

In this example, a message is displayed to the user when the scripting is not available. For scripting-enabled browsers, this message will never be seen even though it is still a part of the page.

SUMMARY

JavaScript is inserted into HTML pages by using the `<script>` element. This element can be used to embed JavaScript into an HTML page, leaving it inline with the rest of the markup, or to include JavaScript that exists in an external file. The following are key points:

- To include external JavaScript files, the `src` attribute must be set to the URL of the file to include, which may be a file on the same server as the containing page or one that exists on a completely different domain.
- All `<script>` elements are interpreted in the order in which they occur on the page. The code contained within a `<script>` element must be completely interpreted before code in the next `<script>` element can begin so long as `defer` and `async` attributes are not used.
- For nondeferred scripts, the browser must complete interpretation of the code inside a `<script>` element before it can continue rendering the rest of the page. For this reason, `<script>` elements are usually included toward the end of the page, after the main content and just before the closing `</body>` tag.
- You can defer a script's execution until after the document has rendered by using the `defer` attribute. Deferred scripts always execute in the order in which they are specified.
- You can indicate that a script need not wait for other scripts and also not block the document rendering by using the `async` attribute. Asynchronous scripts are not guaranteed to execute in the order in which they occur in the page.

By using the `<noscript>` element, you can specify that content is to be shown only if scripting support isn't available on the browser. Any content contained in the `<noscript>` element will not be rendered if scripting is enabled on the browser.

3

Language Basics

WHAT'S IN THIS CHAPTER?

- Reviewing syntax
- Working with data types
- Working with flow-control statements
- Understanding functions

WROX.COM DOWNLOADS FOR THIS CHAPTER

Please note that all the code examples for this chapter are available as a part of this chapter's code download on the book's website at www.wrox.com/go/projavascript4e on the Download Code tab.

At the core of any language is a description of how it should work at the most basic level. This description typically defines syntax, operators, data types, and built-in functionality upon which complex solutions can be built. As previously mentioned, ECMA-262 defines all of this information for JavaScript in the form of a pseudolanguage called ECMAScript.

ECMAScript as defined in ECMA-262, fifth edition, is the most-implemented version among web browsers. The sixth edition is the next to be implemented in browsers, and as of the end of 2017, most major browsers have mostly or fully implemented the specification. For this reason, the following information is based primarily on ECMAScript as defined in the sixth edition.

SYNTAX

ECMAScript's syntax borrows heavily from C and other C-like languages such as Java and Perl. Developers familiar with such languages should have an easy time picking up the somewhat looser syntax of ECMAScript.

Case-Sensitivity

The first concept to understand is that everything is case-sensitive; variables, function names, and operators are all case-sensitive, meaning that a variable named `test` is different from a variable named `Test`. Similarly, `typeof` can't be the name of a function because it's a keyword (described in the next section); however, `typeof` is a perfectly valid function name.

Identifiers

An *identifier* is the name of a variable, function, property, or function argument. Identifiers may be one or more characters in the following format:

- ▶ The first character must be a letter, an underscore (`_`), or a dollar sign (`$`).
- ▶ All other characters may be letters, underscores, dollar signs, or numbers.

Letters in an identifier may include extended ASCII or Unicode letter characters such as `À` and `Æ`, though this is not recommended.

By convention, ECMAScript identifiers use camel case, meaning that the first letter is lowercase and each additional word is offset by a capital letter, like this:

```
firstSecond
myCar
doSomethingImportant
```

Although this is not strictly enforced, it is considered a best practice to adhere to the built-in ECMAScript functions and objects that follow this format.

NOTE *Keywords, reserved words, true, false, and null cannot be used as identifiers. See the section “Keywords and Reserved Words” coming up shortly for more detail.*

Comments

ECMAScript uses C-style comments for both single-line and block comments. A single-line comment begins with two forward-slash characters, such as this:

```
// single line comment
```

A block comment begins with a forward slash and asterisk (`/*`) and ends with the opposite (`*/`), as in this example:

```
/* This is a multi-line
comment */
```

Strict Mode

ECMAScript 5 introduced the concept of *strict mode*. Strict mode is a different parsing and execution model for JavaScript, where some of the erratic behavior of ECMAScript 3 is addressed and errors are thrown for unsafe activities. To enable strict mode for an entire script, include the following at the top:

```
"use strict";
```

Although this may look like a string that isn't assigned to a variable, this is a pragma that tells supporting JavaScript engines to change into strict mode. The syntax was chosen specifically so as not to break ECMAScript 3 syntax.

You may also specify just a function to execute in strict mode by including the pragma at the top of the function body:

```
function doSomething() {  
    "use strict";  
    // function body  
}
```

Strict mode changes many parts of how JavaScript is executed, and as such, strict mode distinctions are pointed out throughout the book. All modern browsers support strict mode.

Statements

Statements in ECMAScript are terminated by a semicolon, though omitting the semicolon makes the parser determine where the end of a statement occurs, as in the following examples:

```
let sum = a + b    // valid even without a semicolon - not recommended  
let diff = a - b; // valid - preferred
```

Even though a semicolon is not required at the end of statements, you should always include one. Including semicolons helps prevent errors of omission, such as not finishing what you were typing, and allows developers to compress ECMAScript code by removing extra white space (such compression causes syntax errors when lines do not end in a semicolon). Including semicolons also improves performance in certain situations because parsers try to correct syntax errors by inserting semicolons where they appear to belong.

Multiple statements can be combined into a code block by using C-style syntax, beginning with a left curly brace (`{`) and ending with a right curly brace (`}`):

```
if (test) {  
    test = false;  
    console.log(test);  
}
```

Control statements, such as `if`, require code blocks only when executing multiple statements. However, it is considered a best practice to always use code blocks with control statements, even if there's only one statement to be executed, as in the following examples:

```
// valid, but error-prone and should be avoided  
if (test)
```

```
    console.log(test);

    // preferred
    if (test) { console.log(test);
    }
```

Using code blocks for control statements makes the intent clearer, and there's less chance for errors when changes need to be made.

KEYWORDS AND RESERVED WORDS

ECMA-262 describes a set of reserved *keywords* that have specific uses, such as indicating the beginning or end of control statements or performing specific operations. By rule, keywords are reserved and cannot be used as identifiers or property names. The complete list of keywords for ECMA-262, sixth edition is as follows:

break	do	in	typeof
case	else	instanceof	var
catch	export	new	void
class	extends	return	while
const	finally	super	with
continue	for	switch	yield
debugger	function	this	
default	if	throw	
delete	import	try	

The specification also describes a set of *future reserved words* that cannot be used as identifiers or property names. Though reserved words don't have any specific usage in the language, they are reserved for future use as keywords.

The following is the complete list of future reserved words defined in ECMA-262, sixth edition:

Always reserved:

```
enum
```

Reserved in strict mode:

```
implements package public
interface protected static
let private
```

Reserved in module code:

```
await
```

These words may still not be used as identifiers but now can be used as property names in objects. Generally speaking, it's best to avoid using both keywords and reserved words as both identifiers and property names to ensure compatibility with past and future ECMAScript editions.

VARIABLES

ECMAScript variables are loosely typed, meaning that a variable can hold any type of data. Every variable is simply a named placeholder for a value. There are three keywords that can be used to declare a variable: `var`, which is available in all ECMAScript versions, and `const` and `let`, which were introduced in ECMAScript 6.

The 'var' Keyword

To define a variable, use the `var` operator (note that `var` is a keyword) followed by the variable name (an identifier, as described earlier), like this:

```
var message;
```

This code defines a variable named `message` that can be used to hold any value. (Without initialization, it holds the special value `undefined`, which is discussed in the next section.) ECMAScript implements variable initialization, so it's possible to define the variable and set its value at the same time, as in this example:

```
var message = "hi";
```

Here, `message` is defined to hold a string value of `"hi"`. Doing this initialization doesn't mark the variable as being a string type; it is simply the assignment of a value to the variable. It is still possible to not only change the value stored in the variable but also change the type of value, such as this:

```
var message = "hi";  
message = 100; // legal, but not recommended
```

In this example, the variable `message` is first defined as having the string value `"hi"` and then overwritten with the numeric value `100`. Although it's not recommended to switch the data type that a variable contains, it is completely valid in ECMAScript.

var Declaration Scope

It's important to note that using the `var` operator to define a variable makes it local to the function scope in which it was defined. For example, defining a variable inside of a function using `var` means that the variable is destroyed as soon as the function exits, as shown here:

```
function test() {  
  var message = "hi"; // local variable  
}  
test();  
console.log(message); // error!
```

Here, the `message` variable is defined within a function using `var`. The function is called `test()`, which creates the variable and assigns its value. Immediately after that, the variable is destroyed so the last line in this example causes an error. It is, however, possible to define a variable globally by simply omitting the `var` operator as follows:

```
function test() {  
  message = "hi"; // global variable  
}  
test();  
console.log(message); // "hi"
```

By removing the `var` operator from the example, the message variable becomes global. As soon as the function `test()` is called, the variable is defined and becomes accessible outside of the function once it has been executed.

NOTE *Although it's possible to define global variables by omitting the `var` operator, this approach is not recommended. Global variables defined locally are hard to maintain and cause confusion because it's not immediately apparent if the omission of `var` was intentional. Strict mode throws a `ReferenceError` when an undeclared variable is assigned a value.*

If you need to define more than one variable, you can do it using a single statement, separating each variable (and optional initialization) with a comma like this:

```
var message = "hi",
    found = false,
    age = 29;
```

Here, three variables are defined and initialized. Because ECMAScript is loosely typed, variable initializations using different data types may be combined into a single statement. Though inserting line breaks and indenting the variables isn't necessary, it helps to improve readability.

When you are running in strict mode, you cannot define variables named `eval` or `arguments`. Doing so results in a syntax error.

var Declaration Hoisting

When using `var`, the following is possible because variables declared using that keyword are hoisted to the top of the function scope:

```
function foo() {
  console.log(age);
  var age = 26;
}
foo(); // undefined
```

This does not throw an error because the ECMAScript runtime technically treats it like this:

```
function foo() {
  var age;
  console.log(age);
  age = 26;
}
foo(); // undefined
```

This is “hoisting,” where the interpreter pulls all variable declarations to the top of its scope. It also allows you to use redundant `var` declarations without penalty:

```
function foo() {
  var age = 16;
  var age = 26;
  var age = 36;
```

```

    console.log(age);
  }
  foo(); // 36

```

'let' Declarations

`let` operates in nearly the same way as `var`, but with some important differences. Most notable is that `let` is block scoped, but `var` is function scoped.

```

if (true) {
  var name = 'Matt';
  console.log(name); // Matt
}
console.log(name); // Matt

if (true) {
  let age = 26;
  console.log(age); // 26
}
console.log(age); // ReferenceError: age is not defined

```

Here, the `age` variable cannot be referenced outside the `if` block because its scope does not extend outside the block. Block scope is strictly a subset of function scope, so any scope limitations that apply to `var` declarations will also apply to `let` declarations.

A `let` declaration also does not allow for any redundant declarations within a block scope. Doing so will result in an error:

```

var name;
var name;

let age;
let age; // SyntaxError; identifier 'age' has already been declared

```

Of course, the JavaScript engine will keep track of identifiers used for variable declarations and the block scope they were declared inside, so nesting using identical identifiers behaves as you would expect with no errors because no redeclaration is occurring:

```

var name = 'Nicholas';
console.log(name); // 'Nicholas'
if (true) {
  var name = 'Matt';
  console.log(name); // 'Matt'
}

let age = 30;
console.log(age); // 30
if (true) {
  let age = 26;
  console.log(age); // 26
}

```

The declaration redundancy errors are not a function of order, and are not affected if `let` is mixed with `var`. The different keywords do not declare different types of variables—they just specify how the variables exist inside the relevant scope.

```
var name;
let name; // SyntaxError

let age;
var age; // SyntaxError
```

Temporal Dead Zone

Another important behavior of `let` distinguishing it from `var` is that `let` declarations cannot be used in a way that assumes hoisting:

```
// name is hoisted
console.log(name); // undefined
var name = 'Matt';

// age is not hoisted
console.log(age); // ReferenceError: age is not defined
let age = 26;
```

When parsing the code, JavaScript engines will still be aware of the `let` declarations that appear later in a block, but these variables will be unable to be referenced in any way before the actual declaration occurs. The segment of execution that occurs before the declaration is referred to as the “temporal dead zone,” and any attempted references to these variables will throw a `ReferenceError`.

Global Declarations

Unlike the `var` keyword, when declaring variables using `let` in the global context, variables will not attach to the `window` object as they do with `var`.

```
var name = 'Matt';
console.log(window.name); // 'Matt'

let age = 26;
console.log(window.age); // undefined
```

However, `let` declarations will still occur inside the global block scope, which will persist for the lifetime of the page. Therefore, you must ensure your page does not attempt duplicate declarations in order to avoid throwing a `SyntaxError`.

Conditional Declaration

When using `var` to declare variables, because the declaration is hoisted, the JavaScript engine will happily combine redundant declarations into a single declaration at the top of the scope. Because `let` declarations are scoped to blocks, it’s not possible to check if a `let` variable has previously been declared and conditionally declare it only if it has not.

```
<script>
  var name = 'Nicholas';
  let age = 26;
</script>
```

```

<script>
  // Suppose this script is unsure about what has already been declared in the page.
  // It will assume variables have not been declared.

  var name = 'Matt';
  // No problems here, since this will be handled as a single hoisted declaration.
  // There is no need to check if it was previously declared.

  let age = 36;
  // This will throw an error when 'age' has already been declared.
</script>

```

Using a `try/catch` statement or the `typeof` operator are not solutions, as the `let` declaration inside the conditional block will be scoped to that block.

```

<script>
  let name = 'Nicholas';
  let age = 36;
</script>

<script>
  // Suppose this script is unsure about what has already been declared in
  the page.
  // It will assume variables have not been declared.

  if (typeof name !== 'undefined') {
    let name;
  }
  // 'name' is restricted to the if {} block scope,
  // so this assignment will act as a global assignment
  name = 'Matt';

  try (age) {
    // If age is not declared, this will throw an error
  }
  catch(error) {
    let age;
  }
  // 'age' is restricted to the catch {} block scope,
  // so this assignment will act as a global assignment
  age = 26;
</script>

```

Because of this, you cannot rely on a conditional declaration pattern with this new ES6 declaration keyword.

NOTE *Not being able to use `let` for conditional declaration is a good thing, as conditional declaration is a bad pattern to have in your codebase. It makes it harder to understand program flow. If you find yourself reaching for this pattern, chances are very good that there is a better way to go about writing it.*

let Declaration in for Loops

Prior to the advent of `let`, `for` loop definition involved using an iterator variable whose definition would bleed outside the loop body:

```
for (var i = 0; i < 5; ++i) {  
  // do loop things  
}  
console.log(i); // 5
```

This is no longer a problem when switching to `let` declarations, as the iterator variable will be scoped only to the `for` loop block:

```
for (let i = 0; i < 5; ++i) {  
  // do loop things  
}  
console.log(i); // ReferenceError: i is not defined
```

When using `var`, a frequent problem encountered was the singular declaration and modification of the iterator variable:

```
for (var i = 0; i < 5; ++i) {  
  setTimeout(() => console.log(i), 0)  
}  
// You might expect this to console.log 0, 1, 2, 3, 4  
// It will actually console.log 5, 5, 5, 5, 5
```

This happens because the loop exits with its iterator variable still set to the value that caused the loop to exit: 5. When the timeouts later execute, they reference this same variable, and consequently `console.log` its final value.

When using `let` to declare the loop iterator, behind the scenes the JavaScript engine will actually declare a new iterator variable each loop iteration. Each `setTimeout` references that separate instance, and therefore it will `console.log` the expected value: the value of the iterator variable when that loop iteration was executed.

```
for (let i = 0; i < 5; ++i) {  
  setTimeout(() => console.log(i), 0)  
}  
// console.logs 0, 1, 2, 3, 4
```

This per-iteration declarative behavior is applicable for all styles of `for` loops, including `for-in` and `for-of` loops.

'const' Declarations

`const` behaves identically to that of `let` but with one important difference—it must be initialized with a value, and that value cannot be redefined after declaration. Attempting to modify a `const` variable will result in a runtime error.

```
const age = 26;  
age = 36; // TypeError: assignment to a constant
```

```

// const still disallows redundant declaration
const name = 'Matt';
const name = 'Nicholas'; // SyntaxError

// const is still scoped to blocks
const name = 'Matt';
if (true) {
  const name = 'Nicholas';
}
console.log(name); // Matt

```

The `const` declaration is only enforced with respect to the reference to the variable that it points to. If a `const` variable references an object, it does not violate the `const` constraints to modify properties inside that object.

```

const person = {};
person.name = 'Matt'; // ok

```

Even though the JavaScript engine is creating new instances of `let` iterator variables in `for` loops, and even though `const` variables behave similarly to `let` variables, you cannot use `const` to declare for loop iterators:

```

for (const i = 0; i < 10; ++i) {} // TypeError: assignment to constant variable

```

However, if you were to declare a for loop variable that is not modified, `const` is allowed—precisely because a new variable is declared for each iteration. This is especially relevant in the case of `for-of` and `for-in` loops:

```

let i = 0;
for (const j = 7; i < 5; ++i) {
  console.log(j);
}
// 7, 7, 7, 7, 7

for (const key in {a: 1, b: 2}) {
  console.log(key);
}
// a, b

for (const value of [1,2,3,4,5]) {
  console.log(value);
}
// 1, 2, 3, 4, 5

```

Declaration Styles and Best Practices

The introduction of `let` and `const` in ECMAScript 6 bring objectively better tooling to the language in the form of increased precision of declaration scope and semantics. It is no secret that the bizarre behavior of `var` declarations caused the JavaScript community to pull its collective hair out for years as a result of all the problems it caused. In the wake of the introduction of these new keywords, there are some increasingly common patterns emerging that can improve code quality.

Don't Use var

With `let` and `const`, most developers will find that they no longer need to use `var` in their codebase anywhere. The patterns that emerge from restricting variable declaration to only `let` and `const` will serve to enforce higher codebase quality thanks to careful management of variable scope, declaration locality, and `const` correctness.

Prefer const Over let

Using `const` declarations allows the browser runtime to enforce constant variables, as well as for static code analysis tools to foresee illegal reassignment operations. Therefore, many developers feel it is to their advantage to, by default, declare variables as `const` unless they know they will need to reassign its value at some point. This allows for developers to more concretely reason about values that they know will never change, and also for quick detection of unexpected behavior in cases where the code execution attempts to perform an unanticipated value reassignment.

DATA TYPES

There are six simple data types (also called *primitive types*) in ECMAScript: Undefined, Null, Boolean, Number, String, and Symbol. Symbol was newly introduced in ECMAScript 6. There is also one complex data type called Object, which is an unordered list of name–value pairs. Because there is no way to define your own data types in ECMAScript, all values can be represented as one of these seven. Having only seven data types may seem like too few to fully represent data; however, ECMAScript's data types have dynamic aspects that make each single data type behave like several.

The typeof Operator

Because ECMAScript is loosely typed, there needs to be a way to determine the data type of a given variable. The `typeof` operator provides that information. Using the `typeof` operator on a value returns one of the following strings:

- "undefined" if the value is undefined
- "boolean" if the value is a Boolean
- "string" if the value is a string
- "number" if the value is a number
- "object" if the value is an object (other than a function) or null
- "function" if the value is a function
- "symbol" if the value is a Symbol

The `typeof` operator is called like this:

```
let message = "some string";
console.log(typeof message); // "string"
console.log(typeof (message)); // "string"
console.log(typeof 95); // "number"
```

In this example, both a variable (`message`) and a numeric literal are passed into the `typeof` operator. Note that because `typeof` is an operator and not a function, no parentheses are required (although they can be used).

Be aware there are a few cases where `typeof` seemingly returns a confusing but technically correct value. Calling `typeof null` returns a value of `"object"`, as the special value `null` is considered to be an empty object reference.

NOTE *Technically, functions are considered objects in ECMAScript and don't represent another data type. However, they do have some special properties, which necessitates differentiating between functions and other objects via the `typeof` operator.*

The Undefined Type

The Undefined type has only one value, which is the special value `undefined`. When a variable is declared using `var` or `let` but not initialized, it is assigned the value of `undefined` as follows:

```
let message;
console.log(message == undefined); // true
```

In this example, the variable `message` is declared without initializing it. When compared with the literal value of `undefined`, the two are equal. This example is identical to the following:

```
let message = undefined;
console.log(message == undefined); // true
```

Here the variable `message` is explicitly initialized to be `undefined`. This is unnecessary because, by default, any uninitialized variable gets the value of `undefined`.

NOTE *Generally speaking, you should never explicitly set a variable to be `undefined`. The literal `undefined` value is provided mainly for comparison and wasn't added until ECMA-262, third edition, to help formalize the difference between an empty object pointer (`null`) and an uninitialized variable.*

Note that a variable containing the value of `undefined` is different from a variable that hasn't been defined at all. Consider the following:

```
let message; // this variable is declared but has a value of undefined

// make sure this variable isn't declared
// let age

console.log(message); // "undefined"
console.log(age); // causes an error
```

In this example, the first `console.log` displays the variable `message`, which is `undefined`. In the second `console.log`, an undeclared variable called `age` is passed into the `console.log()` function, which causes an error because the variable hasn't been declared. Only one useful operation can be performed on an undeclared variable: you can call `typeof` on it (calling `delete` on an undeclared variable won't cause an error, but this isn't very useful and in fact throws an error in strict mode).

The `typeof` operator returns `undefined` when called on an uninitialized variable, but it also returns `undefined` when called on an undeclared variable, which can be a bit confusing. Consider this example:

```
let message; // this variable is declared but has a value of undefined

// make sure this variable isn't declared
// let age

console.log(typeof message); // "undefined"
console.log(typeof age); // "undefined"
```

In both cases, calling `typeof` on the variable returns the string `undefined`. Logically, this makes sense because no real operations can be performed with either variable even though they are technically very different.

NOTE *Even though uninitialized variables are automatically assigned a value of `undefined`, it is advisable to always initialize variables. That way, when `typeof` returns `undefined`, you'll know that it's because a given variable hasn't been declared rather than was simply not initialized.*

The value `undefined` is falsy; therefore, you are able to more succinctly check for it wherever you might need to. Bear in mind, however, that many other possible values are also falsy, so be careful in scenarios where you need to test for an exact value of `undefined` rather than just a falsy value:

```
let message; // this variable is declared but has a value of undefined
// 'age' is not declared

if (message) {
  // This block will not execute
}

if (!message) {
  // This block will execute
}

if (age) {
  // This will throw an error
}
```

The Null Type

The Null type is the second data type that has only one value: the special value `null`. Logically, a `null` value is an empty object pointer, which is why `typeof` returns `"object"` when it's passed a `null` value in the following example:

```
let car = null;
console.log(typeof car); // "object"
```

When defining a variable that is meant to later hold an object, it is advisable to initialize the variable to `null` as opposed to anything else. That way, you can explicitly check for the value `null` to determine if the variable has been filled with an object reference at a later time, such as in this example:

```
if (car !== null) {
  // do something with car
}
```

The value `undefined` is a derivative of `null`, so ECMA-262 defines them to be superficially equal as follows:

```
console.log(null == undefined); // true
```

Using the equality operator (`==`) between `null` and `undefined` always returns `true`, though keep in mind that this operator converts its operands for comparison purposes (covered in detail later in this chapter).

Even though `null` and `undefined` are related, they have very different uses. As mentioned previously, you should never explicitly set the value of a variable to `undefined`, but the same does not hold true for `null`. Any time an object is expected but is not available, `null` should be used in its place. This helps to keep the paradigm of `null` as an empty object pointer and further differentiates it from `undefined`.

The `null` type is `falsy`; therefore, you are able to more succinctly check for it wherever you might need to. Bear in mind, however, that many other possible values are also `falsy`, so be careful in scenarios where you need to test for an exact value of `null` rather than just a `falsy` value:

```
let message = null;
let age;

if (message) {
  // This block will not execute
}

if (!message) {
  // This block will execute
}

if (age) {
  // This block will not execute
}

if (!age) {
  // This block will execute
}
```

The Boolean Type

The Boolean type is one of the most frequently used types in ECMAScript and has only two literal values: `true` and `false`. These values are distinct from numeric values, so `true` is not equal to 1, and `false` is not equal to 0. Assignment of Boolean values to variables is as follows:

```
let found = true;
let lost = false;
```

Note that the Boolean literals `true` and `false` are case-sensitive, so `True` and `False` (and other mixings of uppercase and lowercase) are valid as identifiers but not as Boolean values.

Though there are just two literal Boolean values, all types of values have Boolean equivalents in ECMAScript. To convert a value into its Boolean equivalent, the special `Boolean()` casting function is called, like this:

```
let message = "Hello world!";
let messageAsBoolean = Boolean(message);
```

In this example, the string `message` is converted into a Boolean value and stored in `messageAsBoolean`. The `Boolean()` casting function can be called on any type of data and will always return a Boolean value. The rules for when a value is converted to `true` or `false` depend on the data type as much as the actual value. The following table outlines the various data types and their specific conversions.

DATA TYPE	VALUES CONVERTED TO TRUE	VALUES CONVERTED TO FALSE
Boolean	<code>true</code>	<code>false</code>
String	Any nonempty string	<code>""</code> (empty string)
Number	Any nonzero number (including infinity)	0, NaN (See the “NaN” section later in this chapter.)
Object	Any object	<code>null</code>
Undefined	n/a	<code>undefined</code>

These conversions are important to understand because flow-control statements, such as the `if` statement, automatically perform this Boolean conversion, as shown here:

```
let message = "Hello world!";
if (message) {
  console.log("Value is true");
}
```

In this example, the `console.log` will be displayed because the string `message` is automatically converted into its Boolean equivalent (`true`). It's important to understand what variable you're using in a flow-control statement because of this automatic conversion. Mistakenly using an object instead of a Boolean can drastically alter the flow of your application.

The Number Type

Perhaps the most interesting data type in ECMAScript is `Number`, which uses the IEEE–754 format to represent both integers and floating-point values (also called double–precision values in some languages). To support the various types of numbers, there are several different number literal formats.

The most basic number literal format is that of a decimal integer, which can be entered directly as shown here:

```
let intNum = 55; // integer
```

Integers can also be represented as either octal (base 8) or hexadecimal (base 16) literals. For an octal literal, the first digit must be a zero (0) followed by a sequence of octal digits (numbers 0 through 7). If a number out of this range is detected in the literal, then the leading zero is ignored and the number is treated as a decimal, as in the following examples:

```
let octalNum1 = 070; // octal for 56
let octalNum2 = 079; // invalid octal - interpreted as 79
let octalNum3 = 08;  // invalid octal - interpreted as 8
```

Octal literals are invalid when running in strict mode and will cause the JavaScript engine to throw a syntax error.

To create a hexadecimal literal, you must make the first two characters `0x` (case insensitive), followed by any number of hexadecimal digits (0 through 9, and A through F). Letters may be in uppercase or lowercase. Here's an example:

```
let hexNum1 = 0xA; // hexadecimal for 10
let hexNum2 = 0x1f; // hexadecimal for 31
```

Numbers created using octal or hexadecimal format are treated as decimal numbers in all arithmetic operations.

NOTE *Because of the way that numbers are stored in JavaScript, it is actually possible to have a value of positive zero (+0) and negative zero (−0). Positive zero and negative zero are considered equivalent in all cases but are noted in this text for clarity.*

Floating-Point Values

To define a floating-point value, you must include a decimal point and at least one number after the decimal point. Although an integer is not necessary before a decimal point, it is recommended. Here are some examples:

```
let floatNum1 = 1.1;
let floatNum2 = 0.1;
let floatNum3 = .1; // valid, but not recommended
```

Because storing floating-point values uses twice as much memory as storing integer values, ECMAScript always looks for ways to convert values into integers. When there is no digit after the decimal point, the number becomes an integer. Likewise, if the number being represented is a whole number (such as 1.0), it will be converted into an integer, as in this example:

```
let floatNum1 = 1.;    // missing digit after decimal - interpreted as integer 1
let floatNum2 = 10.0; // whole number - interpreted as integer 10
```

For very large or very small numbers, floating-point values can be represented using *e-notation*. E-notation is used to indicate a number that should be multiplied by 10 raised to a given power. The format of e-notation in ECMAScript is to have a number (integer or floating-point) followed by an uppercase or lowercase letter E, followed by the power of 10 to multiply by. Consider the following:

```
let floatNum = 3.125e7; // equal to 31250000
```

In this example, `floatNum` is equal to 31,250,000 even though it is represented in a more compact form using e-notation. The notation essentially says, “Take 3.125 and multiply it by 10^7 .”

E-notation can also be used to represent very small numbers, such as 0.000000000000000003, which can be written more succinctly as $3e-17$. By default, ECMAScript converts any floating-point value with at least six zeros after the decimal point into e-notation (for example, 0.0000003 becomes $3e-7$).

Floating-point values are accurate up to 17 decimal places but are far less accurate in arithmetic computations than whole numbers. For instance, adding 0.1 and 0.2 yields 0.30000000000000004 instead of 0.3. These small rounding errors make it difficult to test for specific floating-point values. Consider this example:

```
if (a + b == 0.3) {          // avoid!
  console.log("You got 0.3.");
}
```

Here, the sum of two numbers is tested to see if it’s equal to 0.3. This will work for 0.05 and 0.25 and for 0.15 and 0.15. But if applied to 0.1 and 0.2, as discussed previously, this test would fail. Therefore you should never test for specific floating-point values.

NOTE *It’s important to understand that rounding errors are a side effect of the way floating-point arithmetic is done in IEEE-754–based numbers and is not unique to ECMAScript. Other languages that use the same format have the same issues.*

Range of Values

Not all numbers in the world can be represented in ECMAScript because of memory constraints. The smallest number that can be represented in ECMAScript is stored in `Number.MIN_VALUE` and is $5e-324$ on most browsers; the largest number is stored in `Number.MAX_VALUE` and is $1.7976931348623157e+308$ on most browsers. If a calculation results in a number that cannot be represented by JavaScript’s numeric range, the number automatically gets the special value of `Infinity`. Any negative number that can’t be represented is `-Infinity` (negative infinity), and any positive number that can’t be represented is simply `Infinity` (positive infinity).

If a calculation returns either positive or negative `Infinity`, that value cannot be used in any further calculations, because `Infinity` has no numeric representation with which to calculate. To determine if a value is finite (that is, it occurs between the minimum and the maximum), there is the `isFinite()` function. This function returns `true` only if the argument is between the minimum and the maximum values, as in this example:

```
let result = Number.MAX_VALUE + Number.MAX_VALUE;
console.log(isFinite(result)); // false
```

Though it is rare to do calculations that take values outside of the range of finite numbers, it is possible and should be monitored when doing very large or very small calculations.

NOTE You can also get the values of positive and negative `Infinity` by accessing `Number.NEGATIVE_INFINITY` and `Number.POSITIVE_INFINITY`. As you may expect, these properties contain the values `-Infinity` and `Infinity`, respectively.

NaN

There is a special numeric value called `NaN`, short for *Not a Number*, which is used to indicate when an operation intended to return a number has failed (as opposed to throwing an error). For example, dividing any number by 0 typically causes an error in other programming languages, halting code execution. In ECMAScript, dividing a number by 0 returns `NaN`, which allows other processing to continue.

The value `NaN` has a couple of unique properties. First, any operation involving `NaN` always returns `NaN` (for instance, `NaN/10`), which can be problematic in the case of multistep computations. Second, `NaN` is not equal to any value, including `NaN`. For example, the following returns `false`:

```
console.log(NaN == NaN); // false
```

For this reason, ECMAScript provides the `isNaN()` function. This function accepts a single argument, which can be of any data type, to determine if the value is “not a number.” When a value is passed into `isNaN()`, an attempt is made to convert it into a number. Some nonnumerical values convert into numbers directly, such as the string `"10"` or a Boolean value. Any value that cannot be converted into a number causes the function to return `true`. Consider the following:

```
console.log(isNaN(NaN)); // true
console.log(isNaN(10)); // false - 10 is a number
console.log(isNaN("10")); // false - can be converted to number 10
console.log(isNaN("blue")); // true - cannot be converted to a number
console.log(isNaN(true)); // false - can be converted to number 1
```

This example tests five different values. The first test is on the value `NaN` itself, which, obviously, returns `true`. The next two tests use numeric 10 and the string `"10"`, which both return `false` because the numeric value for each is 10. The string `"blue"`, however, cannot be converted into a number, so the function returns `true`. The Boolean value of `true` can be converted into the number 1, so the function returns `false`.

NOTE *Although typically not done, `isNaN()` can be applied to objects. In that case, the object's `valueOf()` method is first called to determine if the returned value can be converted into a number. If not, the `toString()` method is called and its returned value is tested as well. This is the general way that built-in functions and operators work in ECMAScript and is discussed more in the “Operators” section later in this chapter.*

Number Conversions

There are three functions to convert nonnumeric values into numbers: the `Number()` casting function, the `parseInt()` function, and the `parseFloat()` function. The first function, `Number()`, can be used on any data type; the other two functions are used specifically for converting strings to numbers. Each of these functions reacts differently to the same input.

The `Number()` function performs conversions based on these rules:

- When applied to Boolean values, `true` and `false` get converted into 1 and 0, respectively.
- When applied to numbers, the value is simply passed through and returned.
- When applied to `null`, `Number()` returns 0.
- When applied to `undefined`, `Number()` returns `NaN`.
- When applied to strings, the following rules are applied:
 - If the string contains only numeric characters, optionally preceded by a plus or minus sign, it is always converted to a decimal number, so `Number("1")` becomes 1, `Number("123")` becomes 123, and `Number("011")` becomes 11 (note: leading zeros are ignored).
 - If the string contains a valid floating-point format, such as `"1.1"`, it is converted into the appropriate floating-point numeric value (once again, leading zeros are ignored).
 - If the string contains a valid hexadecimal format, such as `"0xf"`, it is converted into an integer that matches the hexadecimal value.
 - If the string is empty (contains no characters), it is converted to 0.
 - If the string contains anything other than these previous formats, it is converted into `NaN`.
- When applied to objects, the `valueOf()` method is called and the returned value is converted based on the previously described rules. If that conversion results in `NaN`, the `toString()` method is called and the rules for converting strings are applied.

Converting to numbers from various data types can get complicated, as indicated by the number of rules there are for `Number()`. Here are some concrete examples:

```
let num1 = Number("Hello world!"); // NaN
let num2 = Number("");           // 0
```

```
let num3 = Number("000011"); // 11
let num4 = Number(true); // 1
```

In these examples, the string "Hello world" is converted into NaN because it has no corresponding numeric value, and the empty string is converted into 0. The string "000011" is converted to the number 11 because the initial zeros are ignored. Last, the value true is converted to 1.

NOTE *The unary plus operator, discussed in the “Operators” section later in this chapter, works the same as the Number() function.*

Because of the complexities and oddities of the Number() function when converting strings, the parseInt() function is usually a better option when you are dealing with integers. The parseInt() function examines the string much more closely to see if it matches a number pattern. Leading white space in the string is ignored until the first non-white space character is found. If this first character isn't a number, the minus sign, or the plus sign, parseInt() always returns NaN, which means the empty string returns NaN (unlike with Number(), which returns 0). If the first character is a number, plus, or minus, then the conversion goes on to the second character and continues on until either the end of the string is reached or a nonnumeric character is found. For instance, "1234blue" is converted to 1234 because "blue" is completely ignored. Similarly, "22.5" will be converted to 22 because the decimal is not a valid integer character.

Assuming that the first character in the string is a number, the parseInt() function also recognizes the various integer formats (decimal, octal, and hexadecimal, as discussed previously). This means when the string begins with "0x", it is interpreted as a hexadecimal integer; if it begins with "0" followed by a number, it is interpreted as an octal value.

Here are some conversion examples to better illustrate what happens:

```
let num1 = parseInt("1234blue"); // 1234
let num2 = parseInt(""); // NaN
let num3 = parseInt("0xA"); // 10 - hexadecimal
let num4 = parseInt(22.5); // 22
let num5 = parseInt("70"); // 70 - decimal
let num6 = parseInt("0xf"); // 15 - hexadecimal
```

All of the different numeric formats can be confusing to keep track of, so parseInt() provides a second argument: the radix (number of digits). If you know that the value you're parsing is in hexadecimal format, you can pass in the radix 16 as a second argument and ensure that the correct parsing will occur, as shown here:

```
let num = parseInt("0xAF", 16); // 175
```

In fact, by providing the hexadecimal radix, you can leave off the leading "0x" and the conversion will work as follows:

```
let num1 = parseInt("AF", 16); // 175
let num2 = parseInt("AF"); // NaN
```

In this example, the first conversion occurs correctly, but the second conversion fails. The difference is that the radix is passed in on the first line, telling `parseInt()` that it will be passed a hexadecimal string; the second line sees that the first character is not a number and stops automatically.

Passing in a radix can greatly change the outcome of the conversion. Consider the following:

```
let num1 = parseInt("10", 2); // 2 - parsed as binary
let num2 = parseInt("10", 8); // 8 - parsed as octal
let num3 = parseInt("10", 10); // 10 - parsed as decimal
let num4 = parseInt("10", 16); // 16 - parsed as hexadecimal
```

Because leaving off the radix allows `parseInt()` to choose how to interpret the input, it's advisable to always include a radix to avoid errors.

NOTE *Most of the time you'll be parsing decimal numbers, so it's good to always include 10 as the second argument.*

The `parseFloat()` function works in a similar way to `parseInt()`, looking at each character starting in position 0. It also continues to parse the string until it reaches either the end of the string or a character that is invalid in a floating-point number. This means that a decimal point is valid the first time it appears, but a second decimal point is invalid and the rest of the string is ignored, resulting in "22.34.5" being converted to 22.34.

Another difference in `parseFloat()` is that initial zeros are always ignored. This function will recognize any of the floating-point formats discussed earlier, as well as the decimal format (leading zeros are always ignored). Hexadecimal numbers always become 0. Because `parseFloat()` parses only decimal values, there is no radix mode. A final note: if the string represents a whole number (no decimal point or only a zero after the decimal point), `parseFloat()` returns an integer. Here are some examples:

```
let num1 = parseFloat("1234blue"); // 1234 - integer
let num2 = parseFloat("0xA"); // 0
let num3 = parseFloat("22.5"); // 22.5
let num4 = parseFloat("22.34.5"); // 22.34
let num5 = parseFloat("0908.5"); // 908.5
let num6 = parseFloat("3.125e7"); // 31250000
```

The String Type

The String data type represents a sequence of zero or more 16-bit Unicode characters. Strings can be delineated by either double quotes ("), single quotes ('), or backticks (`), so all of the following are legal:

```
let firstName = "John";
let lastName = 'Jacob';
let lastName = `Jingleheimerschmidt`
```

Unlike some languages in which using different quotes changes how the string is interpreted, there is no difference in the syntaxes in ECMAScript. Note, however, that a string beginning with a certain character must end with the same character. For example, the following will cause a syntax error:

```
let firstName = 'Nicholas"; // syntax error - quotes must match
```

Character Literals

The String data type includes several character literals to represent nonprintable or otherwise useful characters, as listed in the following table:

LITERAL	MEANING
<code>\n</code>	New line
<code>\t</code>	Tab
<code>\b</code>	Backspace
<code>\r</code>	Carriage return
<code>\f</code>	Form feed
<code>\\</code>	Backslash (\)
<code>\'</code>	Single quote (')—used when the string is delineated by single quotes. Example: <code>'He said, \'hey.\''</code> .
<code>\"</code>	Double quote (")—used when the string is delineated by double quotes. Example: <code>"He said, \"hey.\""</code> .
<code>\`</code>	Backtick (`)—used when the string is delineated by backticks. Example: <code>`He said, `hey.`</code> .
<code>\xnn</code>	A character represented by hexadecimal code <code>nn</code> (where <code>n</code> is a hexadecimal digit 0-F). Example: <code>\x41</code> is equivalent to <code>"A"</code> .
<code>\unnnn</code>	A Unicode character represented by the hexadecimal code <code>nnnn</code> (where <code>n</code> is a hexadecimal digit 0-F). Example: <code>\u03a3</code> is equivalent to the Greek character Σ .

These character literals can be included anywhere with a string and will be interpreted as if they were a single character, as shown here:

```
let text = "This is the letter sigma: \u03a3.";
```

In this example, the variable `text` is 28 characters long even though the escape sequence is 6 characters long. The entire escape sequence represents a single character, so it is counted as such.

The length of any string can be returned by using the `length` property, as follows:

```
console.log(text.length); // 28
```

This property returns the number of 16-bit characters in the string.

NOTE *If a string contains double-byte characters, the `length` property may not accurately return the number of characters in the string. Mitigation strategies for this are detailed in the Basic Reference Types chapter.*

The Nature of Strings

Strings are immutable in ECMAScript, meaning that once they are created, their values cannot change. To change the string held by a variable, the original string must be destroyed and the variable filled with another string containing a new value, like this:

```
let lang = "Java";
lang = lang + "Script";
```

Here, the variable `lang` is defined to contain the string `"Java"`. On the next line, `lang` is redefined to combine `"Java"` with `"Script"`, making its value `"JavaScript"`. This happens by creating a new string with enough space for 10 characters and then filling that string with `"Java"` and `"Script"`. The last step in the process is to destroy the original string `"Java"` and the string `"Script"`, because neither is necessary anymore. All of this happens behind the scenes, which is why older browsers (such as pre-1.0 versions of Firefox and Internet Explorer 6.0) had very slow string concatenation. These inefficiencies were addressed in later versions of these browsers.

Converting to a String

There are two ways to convert a value into a string. The first is to use the `toString()` method that almost every value has. This method's only job is to return the string equivalent of the value. Consider this example:

```
let age = 11;
let ageAsString = age.toString(); // the string "11"
let found = true;
let foundAsString = found.toString(); // the string "true"
```

The `toString()` method is available on values that are numbers, Booleans, objects, and strings. (Yes, each string has a `toString()` method that simply returns a copy of itself.) If a value is `null` or `undefined`, this method is not available.

In most cases, `toString()` doesn't have any arguments. However, when used on a number value, `toString()` actually accepts a single argument: the radix in which to output the number. By default, `toString()` always returns a string that represents the number as a decimal, but by passing in a radix, `toString()` can output the value in binary, octal, hexadecimal, or any other valid base, as in this example:

```
let num = 10;
console.log(num.toString()); // "10"
console.log(num.toString(2)); // "1010"
console.log(num.toString(8)); // "12"
console.log(num.toString(10)); // "10"
console.log(num.toString(16)); // "a"
```

This example shows how the output of `toString()` can change for numbers when providing a radix. The value 10 can be output into any number of numeric formats. Note that the default (with no argument) is the same as providing a radix of 10.

If you're not sure that a value isn't `null` or `undefined`, you can use the `String()` casting function, which always returns a string regardless of the value type. The `String()` function follows these rules:

- If the value has a `toString()` method, it is called (with no arguments) and the result is returned.
- If the value is `null`, "null" is returned.
- If the value is `undefined`, "undefined" is returned.

Consider the following:

```
let value1 = 10;
let value2 = true;
let value3 = null;
let value4;

console.log(String(value1)); // "10"
console.log(String(value2)); // "true"
console.log(String(value3)); // "null"
console.log(String(value4)); // "undefined"
```

Here, four values are converted into strings: a number, a Boolean, `null`, and `undefined`. The result for the number and the Boolean are the same as if `toString()` were called. Because `toString()` isn't available on "null" and "undefined", the `String()` method simply returns literal text for those values.

NOTE You can also convert a value to a string by adding an empty string ("") to that value using the plus operator (discussed in the “Operators” section later in this chapter).

Template Literals

New in ECMAScript 6 is the capability to define strings using template literals. Unlike their single and double quoted counterparts, template literals respect new line characters, and can be defined spanning multiple lines:

```
let myMultiLineString = 'first line\nsecond line';
let myMultiLineTemplateLiteral = `first line
second line`;

console.log(myMultiLineString);
// first line
// second line"
```



```
console.log(myMultiLineTemplateLiteral);
// first line
// second line

console.log(myMultiLineString === myMultiLinetemplateLiteral); // true
```

As the name suggests, template literals are especially useful when defining templates, such as HTML:

```
let pageHTML = `
<div>
  <a href="#">
    <span>Jake</span>
  </a>
</div>`;
```

Because template literals will exactly match the whitespace inside the backticks, special care will need to be applied when defining them. A correctly formatted template string may appear to have improper indentation:

```
// This template literal has 25 spaces following the line return character
let myTemplateLiteral = `first line
                        second line`;
console.log(myTemplateLiteral.length); // 47

// This template literal begins with a line return character
let secondTemplateLiteral = `
first line
second line`;
console.log(secondTemplateLiteral[0] === '\n'); // true

// This template literal has no unexpected whitespace characters
let thirdTemplateLiteral = `first line
second line`;
console.log(thirdTemplateLiteral[0]);
// first line
// second line
```

Interpolation

One of the most useful features of template literals is their support for interpolation, which allows you to insert values at one or more places inside a single unbroken definition. Technically, template literals aren't strings, they are special JavaScript syntactical expressions that evaluate into strings. Template literals are evaluated immediately when they are defined and converted into a string instance, and any interpolated variables will be drawn from its immediate scope.

This can be accomplished using a JavaScript expression inside `${}`:

```
let value = 5;
let exponent = 'second';

// Formerly, interpolation was accomplished as follows:
let interpolatedString =
  value + ' to the ' + exponent + ' power is ' + (value * value);
```

```
// The same thing accomplished with template literals:
let interpolatedTemplateLiteral =
  `${ value } to the ${ exponent } power is ${ value * value }`;

console.log(interpolatedString);           // 5 to the second power is 25
console.log(interpolatedTemplateLiteral);  // 5 to the second power is 25
```

The value being interpolated will eventually be coerced into a string using `toString()`, but any JavaScript expression can safely be interpolated. Nesting template strings is safe with no escaping required:

```
console.log(`Hello, ${ `World` }!`); // Hello, World!
```

`toString()` is invoked to coerce expression result into string:

```
let foo = { toString: () => 'World' };
console.log(`Hello, ${ foo }!`); // Hello, World!
```

Invoking functions and methods inside interpolated expressions is allowed:

```
function capitalize(word) {
  return `${ word[0].toUpperCase() }${ word.slice(1) }`;
}
console.log(`${ capitalize('hello') }, ${ capitalize('world') }!`); // Hello, World!
```

Additionally, templates can safely interpolate their previous value:

```
let value = '';
function append() {
  value = `${value}abc`;
  console.log(value);
}
append(); // abc
append(); // abcabc
append(); // abcabcabc
```

Template Literal Tag Functions

Template literals also support the ability to define *tag functions*, which are able to define custom interpolation behavior. The tag function is passed the individual pieces after the template has been split by the interpolation token and after the expressions have been evaluated.

A tag function is defined as a regular function and is applied to a template literal by being prepended to it, as shown in the code that follows. The tag function will be passed the template literal split into its pieces: the first argument is an array of the raw strings, and the remaining arguments are the results of the evaluated expressions. The return value of this function will be the string evaluated from the template literal.

This is best demonstrated by example:

```
let a = 6;
let b = 9;
```

```

function simpleTag(strings, aValExpression, bValExpression, sumExpression) {
  console.log(strings);
  console.log(aValExpression);
  console.log(bValExpression);
  console.log(sumExpression);

  return 'foobar';
}

let untaggedResult = `${ a } + ${ b } = ${ a + b }`;
let taggedResult = simpleTag`${ a } + ${ b } = ${ a + b }`;
// ["", " + ", " = ", ""]
// 6
// 9
// 15

console.log(untaggedResult); // "6 + 9 = 15"
console.log(taggedResult); // "foobar"

```

Because there are a variable number of expression arguments, using the spread operator to combine them into a single collection is usually prudent:

```

let a = 6;
let b = 9;

function simpleTag(strings, ...expressions) {
  console.log(strings);
  for(const expression of expressions) {
    console.log(expression);
  }

  return 'foobar';
}

let taggedResult = simpleTag`${ a } + ${ b } = ${ a + b }`;
// ["", " + ", " = ", ""]
// 6
// 9
// 15

console.log(taggedResult); // "foobar"

```

For a template literal with n interpolated values, the number of expression arguments to the tag function will always be n , and the number of string pieces in the first argument will always be exactly $n + 1$. Therefore, if you wished to “zip” the strings and the evaluated expressions together into the default returned string, you could do so as follows:

```

let a = 6;
let b = 9;

function zipTag(strings, ...expressions) {
  return strings[0] +
    expressions.map((e, i) => `${e}${strings[i + 1]}`)
      .join('');
}

let untaggedResult = `${ a } + ${ b } = ${ a + b }`;

```

```
let taggedResult = zipTag`${ a } + ${ b } = ${ a + b }`;

console.log(untaggedResult); // "6 + 9 = 15"
console.log(taggedResult);   // "6 + 9 = 15"
```

Raw Strings

It is also possible to use template literals to give you access to the raw template literal contents without being converted into actual character representations, such as a new line or Unicode character. This can be done by using the `String.raw` tag function, which is available by default.

```
// Unicode demo
// \u00A9 is the copyright symbol
console.log(`\u00A9`); // ©
console.log(String.raw`\u00A9`); // \u00A9

// Newline demo
console.log(`first line\nsecond line`);
// first line
// second line

console.log(String.raw`first line\nsecond line`); // "first line\nsecond line"

// This does not work for actual newline characters: they do not
// undergo conversion from their plaintext escaped equivalents
console.log(`first line
second line`);
// first line
// second line

console.log(String.raw`first line
second line`);
// first line
// second line
```

The raw values are also available as a property on each element in the string piece collection inside the tag function:

```
function printRaw(strings) {
  console.log('Actual characters:');
  for (const string of strings) {
    console.log(string);
  }

  console.log('Escaped characters;');
  for (const rawString of strings.raw) {
    console.log(rawString);
  }
}

printRaw`\u00A9${ 'and' }\n`;
// Actual characters:
// ©
// (newline)
// Escaped characters:
// \u00A9
// \n
```

The Symbol Type

New in ECMAScript 6 is the Symbol data type. Symbols are primitive values, and symbol instances are unique and immutable. The purpose of a symbol is to be a guaranteed unique identifier for object properties that does not risk property collision.

Although they may seem to share some similarities with private properties, symbols are not intended to offer private property behavior (especially because the Object API offers methods to easily discover symbol properties). Instead, symbols are intended to be used as unique tokens that can be used to key special properties with something other than a string.

Basic Symbol Use

Symbols are instantiated using the `Symbol` function. Because it is its own primitive type, the `typeof` operator will identify a symbol as `symbol`.

```
let sym = Symbol();
console.log(typeof sym); // symbol
```

When invoking the function, you can provide an optional string that can be used for identifying the symbol instance when debugging. The string you provide is totally separate from the symbol's definition or identity:

```
let genericSymbol = Symbol();
let otherGenericSymbol = Symbol();

let fooSymbol = Symbol('foo');
let otherFooSymbol = Symbol('foo');

console.log(genericSymbol == otherGenericSymbol); // false
console.log(fooSymbol == otherFooSymbol); // false
```

Symbols do not have a literal string syntax, and this is central to their purpose. The specification governing how symbols operate allows you to create a new `Symbol` instance and use it to key a new property on an object with the guarantee that you will not be overwriting an existing object property—irrespective of whether it is using a string or symbol as a key.

```
let genericSymbol = Symbol();
console.log(genericSymbol); // Symbol()

let fooSymbol = Symbol('foo');
console.log(fooSymbol); // Symbol(foo);
```

Importantly, the `Symbol` function cannot be used with the `new` keyword. The purpose of this is to avoid symbol object wrappers, as is possible with `Boolean`, `String`, and `Number`, which support constructor behavior and instantiate a primitive wrapper object:

```
let myBoolean = new Boolean();
console.log(typeof myBoolean); // "object"

let myString = new String();
console.log(typeof myString); // "object"
```

```
let myNumber = new Number();
console.log(typeof myNumber); // "object"
```

```
let mySymbol = new Symbol(); // TypeError: Symbol is not a constructor
```

Should you want to utilize an object wrapper, you can make use of the `Object()` function:

```
let mySymbol = Symbol();
let myWrappedSymbol = Object(mySymbol);
console.log(typeof myWrappedSymbol); // "object"
```

Using the Global Symbol Registry

In scenarios where different parts of the runtime would like to share and reuse a symbol instance, it is possible to create and reuse symbols in a string-keyed global symbol registry.

This behavior can be achieved using `Symbol.for()`:

```
let fooGlobalSymbol = Symbol.for('foo');
console.log(typeof fooGlobalSymbol); // "object"
```

`Symbol.for()` is an idempotent operation for each string key. The first time it is called with a given string, it will check the global runtime registry, find that no symbol exists, generate a new symbol instance, and add it to the registry. Additional invocations with the same string key will check the global runtime registry, find that a symbol does exist for that string, and return that symbol instance instead.

```
let fooGlobalSymbol = Symbol.for('foo'); // creates new symbol
let otherFooGlobalSymbol = Symbol.for('foo'); // reuses existing symbol

console.log(fooGlobalSymbol === otherFooGlobalSymbol); // true
```

Symbols defined in the global registry are totally distinct from symbols created using `Symbol()`, even if they share a description:

```
let localSymbol = Symbol('foo');
let globalSymbol = Symbol.for('foo');

console.log(localSymbol === globalSymbol); // false
```

The global registry requires string keys, so anything you provide as an argument to `Symbol.for()` will be converted to a string. Additionally, the key used for the registry will also be used as the symbol description.

```
let emptyGlobalSymbol = Symbol.for();
console.log(emptyGlobalSymbol); // Symbol(undefined)
```

It is possible to check against the global registry using `Symbol.keyFor()`, which accepts a symbol and will return the global string key for that global symbol, or undefined if the symbol is not a global symbol.

```
// Create global symbol
let s = Symbol.for('foo');
console.log(Symbol.keyFor(s)); // foo

// Create regular symbol
let s2 = Symbol('bar');
console.log(Symbol.keyFor(s2)); // undefined
```

Using `Symbol.keyFor()` with a non-symbol will throw a `TypeError`:

```
Symbol.keyFor(123); // TypeError: 123 is not a symbol
```

Using Symbols as Properties

Anywhere you can normally use a string or number property, you can also use a symbol. This includes object literal properties and `Object.defineProperty()/Object.defineProperties()`. An object literal can only use a symbol as a property inside the computed property syntax.

```
let s1 = Symbol('foo'),
    s2 = Symbol('bar'),
    s3 = Symbol('baz'),
    s4 = Symbol('qux');

let o = {
  [s1]: 'foo val'
};
// Also valid: o[s1] = 'foo val';

console.log(o);
// {Symbol{foo}: foo val}

Object.defineProperty(o, s2, {value: 'bar val'});

console.log(o);
// {Symbol{foo}: foo val, Symbol(bar): bar val}

Object.defineProperties(o, {
  [s3]: {value: 'baz val'},
  [s4]: {value: 'qux val'}
});

console.log(o);
// {Symbol{foo}: foo val, Symbol(bar): bar val,
//   Symbol{baz}: baz val, Symbol(qux): qux val}
```

Just as `Object.getOwnPropertyNames()` returns an array of regular properties on an object instance, `Object.getOwnPropertySymbols()` returns an array of symbol properties on an object instance. The return values of these two methods are mutually exclusive. `Object.getOwnPropertyDescriptors()` will return an object containing both regular and symbol property descriptors. `Reflect.ownKeys()` will return both types of keys:

```
let s1 = Symbol('foo'),
    s2 = Symbol('bar');

let o = {
  [s1]: 'foo val',
  [s2]: 'bar val',
  baz: 'baz val',
  qux: 'qux val'
};
```

```

console.log(Object.getOwnPropertySymbols(o));
// [Symbol(foo), Symbol(bar)]

console.log(Object.getOwnPropertyNames(o));
// ["baz", "qux"]

console.log(Object.getOwnPropertyDescriptors(o));
// {baz: {...}, qux: {...}, Symbol(foo): {...}, Symbol(bar): {...}}

console.log(Reflect.ownKeys(o));
// ["baz", "qux", Symbol(foo), Symbol(bar)]

```

Because a property counts as a reference to that symbol in memory, Symbols are not lost if directly created and used as properties. However, declining to keep an explicit reference to a property means that traversing all the object's symbol properties will be required to recover the property key:

```

let o = {
  [Symbol('foo')]: 'foo val',
  [Symbol('bar')]: 'bar val'
};

console.log(o);
// {Symbol(foo): "foo val", Symbol(bar): "bar val"}

let barSymbol = Object.getOwnPropertySymbols(o)
  .find((symbol) => symbol.toString().match(/bar/));

console.log(barSymbol);
// Symbol(bar)

```

Well-Known Symbols

Along with the addition of symbols, ECMAScript 6 also introduced a collection of *well-known symbols* that would be used throughout the language to expose internal language behaviors for direct access, overriding, or emulating. These well-known symbols exist as string properties on the `Symbol` factory function.

One of the primary utilities of these well-known symbols is redefining them as to alter the behavior of the native language constructs. For example, because it is known how the `for-of` loop will use the `Symbol.iterator` property on whatever object is provided to it, it is possible to provide a custom definition of `Symbol.iterator`'s value in a custom object in order to control how `for-of` behaves when provided that object.

There is nothing special about these well-known symbols, they are regular string properties on the `Symbol` global that key an instance of a symbol. Each well-defined symbol property is non-writeable, non-enumerable, and non-configurable.

NOTE *In discussions about the ECMAScript specification, you will frequently see these symbols referred to by their specification names, which are prefixed with @@. For example, @@iterator refers to `Symbol.iterator`.*

Symbol.asyncIterator

Per the ECMAScript specification, this symbol is used as a property for “A method that returns the default AsyncIterator for an object. Called by the semantics of the `for-await-of` statement”. It is used to identify the function that implements the asynchronous iterator API.

Language constructs such as the `for-await-of` loop make use of this function to perform asynchronous iteration. They will invoke the function keyed by `Symbol.asyncIterator` and expect it to return an object which implements the Iterator API. In many cases, this will take the form of an `AsyncGenerator`, an object which implements this API:

```
class Foo {
  async *[Symbol.asyncIterator]() {}
}

let f = new Foo();

console.log(f[Symbol.asyncIterator]());
// AsyncGenerator {<suspended>}
```

Specifically, the object produced by the `Symbol.asyncIterator` function should sequentially produce `Promise` instances via its `next()` method. This can be through explicit `next()` method definition or implicitly through an `async` generator function:

```
class Emitter {
  constructor(max) {
    this.max = max;
    this.asyncIdx = 0;
  }

  async *[Symbol.asyncIterator]() {
    while(this.asyncIdx < this.max) {
      yield new Promise((resolve) => resolve(this.asyncIdx++));
    }
  }
}

async function asyncCount() {
  let emitter = new Emitter(5);

  for await(const x of emitter) {
    console.log(x);
  }
}

asyncCount();
// 0
// 1
// 2
// 3
// 4
```

NOTE `Symbol.asyncIterator` is part of the ES2018 specification, and so only very modern browser versions will support it. More details on asynchronous iteration and the `for-await-of` loop can be found in Appendix A.

Symbol.hasInstance

Per the ECMAScript specification, this symbol is used as a property for “A method that determines if a constructor object recognizes an object as one of the constructor’s instances. Called by the semantics of the `instanceof` operator”. The `instanceof` operator provides a way of determining if an object instance has a prototype in its prototype chain. Typical use of the `instanceof` is as follows:

```
function Foo() {}
let f = new Foo();
console.log(f instanceof Foo); // true

class Bar {}
let b = new Bar();
console.log(b instanceof Bar); // true
```

In ES6, the `instanceof` operator is using a `Symbol.hasInstance` function to evaluate this relationship. The `Symbol.hasInstance` keys a function which performs the same behavior but with the operands reversed:

```
function Foo() {}
let f = new Foo();
console.log(Foo[Symbol.hasInstance](f)); // true

class Bar {}
let b = new Bar();
console.log(Bar[Symbol.hasInstance](b)); // true
```

This property is defined on the `Function` prototype, and therefore it is automatically available by default to all function and class definitions. Because the `instanceof` operator will seek the property definition on the prototype chain like any other property, it is possible to redefine the function on an inherited class as a static method:

```
class Bar {}
class Baz extends Bar {
  static [Symbol.hasInstance]() {
    return false;
  }
}

let b = new Baz();
console.log(Bar[Symbol.hasInstance](b)); // true
console.log(b instanceof Bar); // true
console.log(Baz[Symbol.hasInstance](b)); // false
console.log(b instanceof Baz); // false
```

Symbol.isConcatSpreadable

Per the ECMAScript specification, this symbol is used as a property for “A Boolean valued property that if true indicates that an object should be flattened to its array elements by `Array.prototype.concat()`”. The `Array.prototype.concat` method in ES6 will select how to join an array-like object to the array instance based on the type of object it is passed. The value of `Symbol.isConcatSpreadable` allows you to override this behavior.

Array objects by default will be flattened into the existing array; a value of `false` or falsy value will append the entire object to the array. Array-like objects by default will be appended to the array; a value of `true` or truthy value will flatten the array-like object into the array instance. Other objects which are not array-like will be ignored when `Symbol.isConcatSpreadable` is set to `true`.

```
let initial = ['foo'];

let array = ['bar'];
console.log(array[Symbol.isConcatSpreadable]); // undefined
console.log(initial.concat(array));           // ['foo', 'bar']
array[Symbol.isConcatSpreadable] = false;
console.log(initial.concat(array));           // ['foo', Array(1)]

let arrayLikeObject = { length: 1, 0: 'baz' };
console.log(arrayLikeObject[Symbol.isConcatSpreadable]); // undefined
console.log(initial.concat(arrayLikeObject));           // ['foo', {...}]
arrayLikeObject[Symbol.isConcatSpreadable] = true;
console.log(initial.concat(arrayLikeObject));           // ['foo', 'baz']

let otherObject = new Set().add('qux');
console.log(otherObject[Symbol.isConcatSpreadable]); // undefined
console.log(initial.concat(otherObject));             // ['foo', Set(1)]
otherObject[Symbol.isConcatSpreadable] = true;
console.log(initial.concat(otherObject));             // ['foo']
```

Symbol.iterator

Per the ECMAScript specification, this symbol is used as a property for “A method that returns the default Iterator for an object. Called by the semantics of the `for-of` statement”. It is used to identify the function that implements the iterator API.

Language constructs such as the `for-of` loop make use of this function to perform iteration. They will invoke the function keyed by `Symbol.iterator` and expect it to return an object which implements the Iterator API. In many cases, this will take the form of a Generator, an object which implements this API:

```
class Foo {
  *[Symbol.iterator]() {}
}

let f = new Foo();

console.log(f[Symbol.iterator]());
// Generator {<suspended>}
```

Specifically, the object produced by the `Symbol.iterator` function should sequentially produce values via its `next()` method. This can be through explicit `next()` method definition or implicitly through a generator function:

```
class Emitter {
  constructor(max) {
    this.max = max;
    this.idx = 0;
  }

  *[Symbol.iterator]() {
    while(this.idx < this.max) {
      yield this.idx++;
    }
  }
}

function count() {
  let emitter = new Emitter(5);

  for (const x of emitter) {
    console.log(x);
  }
}

count();
// 0
// 1
// 2
// 3
// 4
```

NOTE *Iterator definition is covered in depth in the Iterators and Generators chapter.*

Symbol.match

Per the ECMAScript specification, this symbol is used as a property for “A regular expression method that matches the regular expression against a string. Called by the `String.prototype.match()` method”. The `String.prototype.match()` method will use the function keyed by `Symbol.match` to evaluate the expression. The regular expression prototype has this function defined by default, and therefore all regular expression instances are valid parameters to the `String` method by default:

```
console.log(RegExp.prototype[Symbol.match]);
// f [Symbol.match]() { [native code] }

console.log('foobar'.match(/bar/));
// ["bar", index: 3, input: "foobar", groups: undefined]
```

Providing something other than a regular expression to this method will cause it to be converted to a `RegExp` object. If you wish to circumvent this behavior and have the method use the parameter directly, it is possible to pass something other than a regular expression instance to the `match()` method by defining a `Symbol.match` function to supplant the behavior that would otherwise be exhibited by the regular expression. This function has a single parameter which is the string instance upon which `match()` is invoked. The return value is unrestricted:

```
class FooMatcher {
  static [Symbol.match](target) {
    return target.includes('foo');
  }
}

console.log('foobar'.match(FooMatcher)); // true
console.log('barbaz'.match(FooMatcher)); // false

class StringMatcher {
  constructor(str) {
    this.str = str;
  }

  [Symbol.match](target) {
    return target.includes(this.str);
  }
}

console.log('foobar'.match(new StringMatcher('foo'))); // true
console.log('barbaz'.match(new StringMatcher('qux'))); // false
```

Symbol.replace

Per the ECMAScript specification, this symbol is used as a property for “A regular expression method that replaces matched substrings of a string. Called by the `String.prototype.replace()` method”. The `String.prototype.replace()` method will use the function keyed by `Symbol.replace` to evaluate the expression. The regular expression prototype has this function defined by default, and therefore all regular expression instances are valid parameters to the `String` method by default:

```
console.log(RegExp.prototype[Symbol.replace]);
// f [Symbol.replace]() { [native code] }

console.log('foobarbaz'.replace(/bar/, 'qux'));
// 'fooquxbaz'
```

Providing something other than a regular expression to this method will cause it to be converted to a `RegExp` object. If you wish to circumvent this behavior and have the method use the parameter directly, it is possible to pass something other than a regular expression instance to the `replace()` method by defining a `Symbol.replace` function to supplant the behavior that would otherwise be exhibited by the regular expression. This function has two parameters, the string instance upon which `replace()` is invoked and the replacement string. The return value is unrestricted:

```
class FooReplacer {
  static [Symbol.replace](target, replacement) {
    return target.split('foo').join(replacement);
  }
}
```

```

console.log('barfoobaz'.replace(FooReplacer, 'qux'));
// "barquxbaz"

class StringReplacer {
  constructor(str) {
    this.str = str;
  }

  [Symbol.replace](target, replacement) {
    return target.split(this.str).join(replacement);
  }
}

console.log('barfoobaz'.replace(new StringReplacer('foo'), 'qux'));
// "barquxbaz"

```

Symbol.search

Per the ECMAScript specification, this symbol is used as a property for “A regular expression method that returns the index within a string that matches the regular expression. Called by the `String.prototype.search()` method”. The `String.prototype.search()` method will use the function keyed by `Symbol.search` to evaluate the expression. The regular expression prototype has this function defined by default, and therefore all regular expression instances are valid parameters to the `String` method by default:

```

console.log(RegExp.prototype[Symbol.search]);
// f [Symbol.search]() { [native code] }

console.log('foobar'.search(/bar/));
// 3

```

Providing something other than a regular expression to this method will cause it to be converted to a `RegExp` object. If you wish to circumvent this behavior and have the method use the parameter directly, it is possible to pass something other than a regular expression instance to the `search()` method by defining a `Symbol.search` function to supplant the behavior that would otherwise be exhibited by the regular expression. This function has a single parameter which is the string instance upon which `search()` is invoked. The return value is unrestricted:

```

class FooSearcher {
  static [Symbol.search](target) {
    return target.indexOf('foo');
  }
}

console.log('foobar'.search(FooSearcher)); // 0
console.log('barfoo'.search(FooSearcher)); // 3
console.log('barbaz'.search(FooSearcher)); // -1

class StringSearcher {
  constructor(str) {
    this.str = str;
  }
}

```

```

    [Symbol.search](target) {
      return target.indexOf(this.str);
    }
  }

  console.log('foobar'.search(new StringSearcher('foo'))); // 0
  console.log('barfoo'.search(new StringSearcher('foo'))); // 3
  console.log('barbaz'.search(new StringSearcher('qux'))); // -1

```

Symbol.species

Per the ECMAScript specification, this symbol is used as a property for “A function valued property that is the constructor function that is used to create derived objects”. This is most commonly used for build-in types which expose methods that instantiate derived objects for the return value of an instance method. Defining a static getter method with `Symbol.species` allows you to override the prototype definition for the newly created instance:

```

class Bar extends Array {}
class Baz extends Array {
  static get [Symbol.species]() {
    return Array;
  }
}

let bar = new Bar();
console.log(bar instanceof Array); // true
console.log(bar instanceof Bar); // true
bar = bar.concat('bar');
console.log(bar instanceof Array); // true
console.log(bar instanceof Bar); // true

let baz = new Baz();
console.log(baz instanceof Array); // true
console.log(baz instanceof Baz); // true
baz = baz.concat('baz');
console.log(baz instanceof Array); // true
console.log(baz instanceof Baz); // false

```

Symbol.split

Per the ECMAScript specification, this symbol is used as a property for “A regular expression method that splits a string at the indices that match the regular expression. Called by the `String.prototype.split()` method”. The `String.prototype.split()` method will use the function keyed by `Symbol.split` to evaluate the expression. The regular expression prototype has this function defined by default, and therefore all regular expression instances are valid parameters to the `String` method by default:

```

console.log(RegExp.prototype[Symbol.split]);
// f [Symbol.split]() { [native code] }

console.log('foobarbaz'.split(/bar/));
// ['foo', 'baz']

```

Providing something other than a regular expression to this method will cause it to be converted to a `RegExp` object. If you wish to circumvent this behavior and have the method use the parameter directly, it is possible to pass something other than a regular expression instance to the `split()` method by defining a `Symbol.split` function to supplant the behavior that would otherwise be exhibited by the regular expression. This function has a single parameter which is the string instance upon which `split()` is invoked. The return value is unrestricted:

```
class FooSplitter {
  static [Symbol.split](target) {
    return target.split('foo');
  }
}

console.log('barfoobaz'.split(FooSplitter));
// ["bar", "baz"]

class StringSplitter {
  constructor(str) {
    this.str = str;
  }

  [Symbol.split](target) {
    return target.split(this.str);
  }
}

console.log('barfoobaz'.split(new StringSplitter('foo')));
// ["bar", "baz"]
```

Symbol.toPrimitive

Per the ECMAScript specification, this symbol is used as a property for “A method that converts an object to a corresponding primitive value. Called by the `ToPrimitive` abstract operation”. There are a number of built-in operations which will attempt to coerce an object into a primitive value: a string, a number, or an unspecified primitive type. For a custom object instance, it is possible to divert this behavior by defining a function on the instance’s `Symbol.toPrimitive` property.

Based on a string parameter provided to the function (either `string`, `number`, or `default`), you are able to control the returned primitive:

```
class Foo {}
let foo = new Foo();

console.log(3 + foo);      // "3[object Object]"
console.log(3 - foo);     // NaN
console.log(String(foo));  // "[object Object]"

class Bar {
  constructor() {
    this[Symbol.toPrimitive] = function(hint) {
      switch (hint) {
        case 'number':
          return 3;
        case 'string':
```



```

        return 'string bar';
      case 'default':
      default:
        return 'default bar';
    }
  }
}
let bar = new Bar();

console.log(3 + bar);      // "3default bar"
console.log(3 - bar);     // 0
console.log(String(bar)); // "string bar"

```

Symbol.toStringTag

Per the ECMAScript specification, this symbol is used as a property for “A String valued property that is used in the creation of the default string description of an object. Accessed by the built-in method `Object.prototype.toString()`”.

Object identification via the `toString()` method will retrieve the instance identifier specified by `Symbol.toStringTag`, defaulting to `Object`. Built-in types have this value already specified, but custom class instances require explicit definition:

```

let s = new Set();

console.log(s);                // Set(0) {}
console.log(s.toString());     // [object Set]
console.log(s[Symbol.toStringTag]); // Set

class Foo {}
let foo = new Foo();

console.log(foo);              // Foo {}
console.log(foo.toString());   // [object Object]
console.log(foo[Symbol.toStringTag]); // undefined

class Bar {
  constructor() {
    this[Symbol.toStringTag] = 'Bar';
  }
}
let bar = new Bar();

console.log(bar);              // Bar {}
console.log(bar.toString());   // [object Bar]
console.log(bar[Symbol.toStringTag]); // Bar

```

Symbol.unscopables

Per the ECMAScript specification, this symbol is used as a property for “An object valued property whose own and inherited property names are property names that are excluded from the with environment bindings of the associated object”. Setting this symbol so it keys an object mapping a corresponding property to `true` will prevent a `with` environment binding, as shown here:

```

let o = { foo: 'bar' };

```

```

with (o) {
  console.log(foo); // bar
}

o[Symbol.unscopables] = {
  foo: true
};

with (o) {
  console.log(foo); // ReferenceError
}

```

NOTE *It's not recommended to use with, so using Symbol.unscopables is also not recommended.*

The Object Type

Objects in ECMAScript start out as nonspecific groups of data and functionality. Objects are created by using the `new` operator followed by the name of the object type to create. Developers create their own objects by creating instances of the `Object` type and adding properties and/or methods to it, as shown here:

```
let o = new Object();
```

This syntax is similar to Java, although ECMAScript requires parentheses to be used only when providing arguments to the constructor. If there are no arguments, as in the following example, then the parentheses can be omitted safely (though that's not recommended):

```
let o = new Object; // legal, but not recommended
```

Instances of `Object` aren't very useful on their own, but the concepts are important to understand because, similar to `java.lang.Object` in Java, the `Object` type in ECMAScript is the base from which all other objects are derived. All of the properties and methods of the `Object` type are also present on other, more specific objects.

Each `Object` instance has the following properties and methods:

- `constructor`—The function that was used to create the object. In the previous example, the constructor is the `Object()` function.
- `hasOwnProperty(propertyName)`—Indicates if the given property exists on the object instance (not on the prototype). The property name must be specified as a string (for example, `o.hasOwnProperty("name")`).
- `isPrototypeOf(object)`—Determines if the object is a prototype of another object. (Prototypes are discussed in Chapter 5.)
- `propertyIsEnumerable(propertyName)`—Indicates if the given property can be enumerated using the `for-in` statement (discussed later in this chapter). As with `hasOwnProperty()`, the property name must be a string.

- ▶ `toLocaleString()`—Returns a string representation of the object that is appropriate for the locale of execution environment.
- ▶ `toString()`—Returns a string representation of the object.
- ▶ `valueOf()`—Returns a string, number, or Boolean equivalent of the object. It often returns the same value as `toString()`.

Because `Object` is the base for all objects in ECMAScript, every object has these base properties and methods. Chapters 5 and 6 cover the specifics of how this occurs.

NOTE *Technically speaking, the behavior of objects in ECMA-262 need not necessarily apply to other objects in JavaScript. Objects that exist in the browser environment, such as those in the Browser Object Model (BOM) and Document Object Model (DOM), are considered host objects because they are provided and defined by the host implementation. Host objects aren't governed by ECMA-262 and, as such, may or may not directly inherit from `Object`.*

OPERATORS

ECMA-262 describes a set of *operators* that can be used to manipulate data values. The operators range from mathematical operations (such as addition and subtraction) and bitwise operators to relational operators and equality operators. Operators are unique in ECMAScript in that they can be used on a wide range of values, including strings, numbers, Booleans, and even objects. When used on objects, operators typically call the `valueOf()` and/or `toString()` method to retrieve a value they can work with.

Unary Operators

Operators that work on only one value are called *unary operators*. They are the simplest operators in ECMAScript.

Increment/Decrement

The increment and decrement operators are taken directly from C and come in two versions: prefix and postfix. The prefix versions of the operators are placed before the variable they work on; the postfix ones are placed after the variable. To use a prefix increment, which adds 1 to a numeric value, you place two plus signs (`++`) in front of a variable like this:

```
let age = 29;
++age;
```

In this example, the prefix increment changes the value of `age` to 30 (adding 1 to its previous value of 29). This is effectively equal to the following:

```
let age = 29;
age = age + 1;
```

The prefix decrement acts in a similar manner, subtracting 1 from a numeric value. To use a prefix decrement, place two minus signs (`--`) before a variable, as shown here:

```
let age = 29;
--age;
```

Here the `age` variable is decremented to 28 (subtracting 1 from 29).

When using either a prefix increment or a prefix decrement, the variable's value is changed before the statement is evaluated. (In computer science, this is usually referred to as having a *side effect*.) Consider the following:

```
let age = 29;
let anotherAge = --age + 2;

console.log(age);           // 28
console.log(anotherAge);    // 30
```

In this example, the variable `anotherAge` is initialized with the decremented value of `age` plus 2. Because the decrement happens first, `age` is set to 28, and then 2 is added, resulting in 30.

The prefix increment and decrement are equal in terms of order of precedence in a statement and are therefore evaluated left to right. Consider this example:

```
let num1 = 2;
let num2 = 20;
let num3 = --num1 + num2;
let num4 = num1 + num2;
console.log(num3); // 21
console.log(num4); // 21
```

Here, `num3` is equal to 21 because `num1` is decremented to 1 before the addition occurs. The variable `num4` also contains 21, because the addition is also done using the changed values.

The postfix versions of increment and decrement use the same syntax (`++` and `--`, respectively) but are placed after the variable instead of before it. Postfix increment and decrement differ from the prefix versions in one important way: the increment or decrement doesn't occur until after the containing statement has been evaluated. In certain circumstances, this difference doesn't matter, as in this example:

```
let age = 29;
age++;
```

Moving the increment operator after the variable doesn't change what these statements do, because the increment is the only operation occurring. However, when mixed together with other operations, the difference becomes apparent, as in the following example:

```
let num1 = 2;
let num2 = 20;
let num3 = num1-- + num2;
let num4 = num1 + num2;
console.log(num3); // 22
console.log(num4); // 21
```

With just one simple change in this example, using postfix decrement instead of prefix, you can see the difference. In the prefix example, `num3` and `num4` both ended up equal to 21, whereas this example ends with `num3` equal to 22 and `num4` equal to 21. The difference is that the calculation for `num3` uses the original value of `num1` (2) to complete the addition, whereas `num4` is using the decremented value (1).

All four of these operators work on any values, meaning not just integers but strings, Booleans, floating-point values, and objects. The increment and decrement operators follow these rules regarding values:

- When used on a string that is a valid representation of a number, convert to a number and apply the change. The variable is changed from a string to a number.
- When used on a string that is not a valid number, the variable's value is set to `NaN`. The variable is changed from a string to a number.
- When used on a Boolean value that is `false`, convert to 0 and apply the change. The variable is changed from a Boolean to a number.
- When used on a Boolean value that is `true`, convert to 1 and apply the change. The variable is changed from a Boolean to a number.
- When used on a floating-point value, apply the change by adding or subtracting 1.
- When used on an object, call its `valueOf()` method (discussed more in Chapter 5) to get a value to work with. Apply the other rules. If the result is `NaN`, then call `toString()` and apply the other rules again. The variable is changed from an object to a number.

The following example demonstrates some of these rules:

```
let s1 = "2";
let s2 = "z";
let b = false;
let f = 1.1;
let o = {
  valueOf() {
    return -1;
  }
};

s1++; // value becomes numeric 3
s2++; // value becomes NaN
b++; // value becomes numeric 1
f--; // value becomes 0.10000000000000009 (due to floating-point inaccuracies)
o--; // value becomes numeric -2
```

Unary Plus and Minus

The *unary plus and minus operators* are familiar symbols to most developers and operate the same way in ECMAScript as they do in high-school math. The unary plus is represented by a single plus sign (+) placed before a variable and does nothing to a numeric value, as shown in this example:

```
let num = 25;
num = +num;
console.log(num); // 25
```

When the unary plus is applied to a nonnumeric value, it performs the same conversion as the `Number()` casting function: the Boolean values of `false` and `true` are converted to 0 and 1, string values are parsed according to a set of specific rules, and objects have their `valueOf()` and/or `toString()` method called to get a value to convert.

The following example demonstrates the behavior of the unary plus when acting on different data types:

```
let s1 = "01";
let s2 = "1.1";
let s3 = "z";
let b = false;
let f = 1.1;
let o = {
  valueOf() {
    return -1;
  }
};

s1 = +s1; // value becomes numeric 1
s2 = +s2; // value becomes numeric 1.1
s3 = +s3; // value becomes NaN
b = +b;   // value becomes numeric 0
f = +f;   // no change, still 1.1
o = +o;   // value becomes numeric -1
```

The unary minus operator's primary use is to negate a numeric value, such as converting 1 into -1 . The simple case is illustrated here:

```
let num = 25;
num = -num;
console.log(num); // -25
```

When used on a numeric value, the unary minus simply negates the value (as in this example). When used on nonnumeric values, unary minus applies all of the same rules as unary plus and then negates the result, as shown here:

```
let s1 = "01";
let s2 = "1.1";
let s3 = "z";
let b = false;
let f = 1.1;
let o = {
  valueOf() {
    return -1;
  }
};

s1 = -s1; // value becomes numeric -1
s2 = -s2; // value becomes numeric -1.1
s3 = -s3; // value becomes NaN
b = -b;   // value becomes numeric 0
f = -f;   // change to -1.1
o = -o;   // value becomes numeric 1
```

The unary plus and minus operators are used primarily for basic arithmetic but can also be useful for conversion purposes, as illustrated in the previous example.

Bitwise Operators

The next set of operators works with numbers at their very base level, with the bits that represent them in memory. All numbers in ECMAScript are stored in IEEE-754 64-bit format, but the bitwise operations do not work directly on the 64-bit representation. Instead, the value is converted into a 32-bit integer, the operation takes place, and the result is converted back into 64 bits. To the developer, it appears that only the 32-bit integer exists because the 64-bit storage format is transparent. With that in mind, consider how 32-bit integers work.

Signed integers use the first 31 of the 32 bits to represent the numeric value of the integer. The 32nd bit represents the sign of the number: 0 for positive or 1 for negative. Depending on the value of that bit, called the *sign bit*, the format of the rest of the number is determined. Positive numbers are stored in true binary format, with each of the 31 bits representing a power of 2, starting with the first bit (called bit 0), representing 2^0 , the second bit represents 2^1 , and so on. If any bits are unused, they are filled with 0 and essentially ignored. For example, the number 18 is represented as 000000000000000000000000000010010, or more succinctly as 10010. These are the five most significant bits and can be used, by themselves, to determine the actual value (see Figure 3-1).

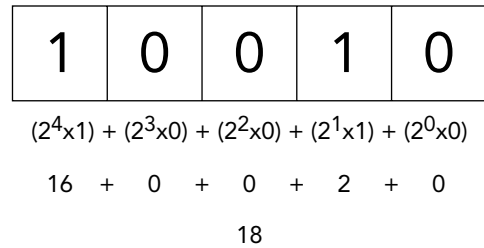

FIGURE 3-1:

Negative numbers are also stored in binary code but in a format called *two's complement*. The two's complement of a number is calculated in three steps:

1. Determine the binary representation of the absolute value (for example, to find -18 , first determine the binary representation of 18).
2. Find the one's complement of the number, which essentially means that every 0 must be replaced with a 1, and vice versa.
3. Add 1 to the result.

Using this process to determine the binary representation -18 , start with the binary representation of 18, which is the following:

```
0000 0000 0000 0000 0000 0000 0001 0010
```

Next, take the one's complement, which is the inverse of this number:

```
1111 1111 1111 1111 1111 1111 1110 1101
```

Finally, add 1 to the one's complement as follows:

```
1111 1111 1111 1111 1111 1111 1110 1101
                        1
-----
1111 1111 1111 1111 1111 1111 1110 1110
```

So the binary equivalent of -18 is `111111111111111111111111111101110`. Keep in mind that you have no access to bit 31 when dealing with signed integers.

ECMAScript does its best to keep all of this information from you. When outputting a negative number as a binary string, you get the binary code of the absolute value preceded by a minus sign, as in this example:

```
let num = -18;
console.log(num.toString(2)); // "-10010"
```

When you convert the number -18 to a binary string, the result is `-10010`. The conversion process interprets the two's complement and represents it in an arguably more logical form.

NOTE *By default, all integers are represented as signed in ECMAScript. There is, however, such a thing as an unsigned integer. In an unsigned integer, the 32nd bit doesn't represent the sign because there are only positive numbers. Unsigned integers also can be larger, because the extra bit becomes part of the number instead of an indicator of the sign.*

When you apply bitwise operators to numbers in ECMAScript, a conversion takes place behind the scenes: the 64-bit number is converted into a 32-bit number, the operation is performed, and then the 32-bit result is stored back into a 64-bit number. This gives the illusion that you're dealing with true 32-bit numbers, which makes the binary operations work in a way similar to the operations of other languages. A curious side effect of this conversion is that the special values `NaN` and `Infinity` both are treated as equivalent to `0` when used in bitwise operations.

If a bitwise operator is applied to a nonnumeric value, the value is first converted into a number using the `Number()` function (this is done automatically) and then the bitwise operation is applied. The resulting value is a number.

Bitwise NOT

The bitwise NOT is represented by a tilde (`~`) and simply returns the one's complement of the number. Bitwise NOT is one of just a few ECMAScript operators related to binary mathematics. Consider this example:

```
let num1 = 25;           // binary 0000000000000000000000000000011001
let num2 = ~num1;       // binary 1111111111111111111111111111100110
console.log(num2);      // -26
```

Here, the bitwise NOT operator is used on `25`, producing `-26` as the result. This is the end effect of the bitwise NOT: it negates the number and subtracts 1. The same outcome is produced with the following code:

```
let num1 = 25;
let num2 = -num1 - 1;
console.log(num2);      // "-26"
```

Realistically, though this returns the same result, the bitwise operation is much faster because it works at the very lowest level of numeric representation.

Bitwise AND

The bitwise AND operator is indicated by the ampersand character (&) and works on two values. Essentially, bitwise AND lines up the bits in each number and then, using the rules in the following truth table, performs an AND operation between the two bits in the same position.

BIT FROM FIRST NUMBER	BIT FROM SECOND NUMBER	RESULT
1	1	1
1	0	0
0	1	0
0	0	0

A bitwise AND operation returns 1 if both bits are 1. It returns 0 if any bits are 0.

As an example, to AND the numbers 25 and 3 together, use the following code:

```
let result = 25 & 3;
console.log(result); // 1
```

The result of a bitwise AND between 25 and 3 is 1. Why is that? Take a look:

```
25 = 0000 0000 0000 0000 0000 0000 0001 1001
 3 = 0000 0000 0000 0000 0000 0000 0000 0011
-----
AND = 0000 0000 0000 0000 0000 0000 0000 0001
```

As you can see, only one bit (bit 0) contains a 1 in both 25 and 3. Because of this, every other bit of the resulting number is set to 0, making the result equal to 1.

Bitwise OR

The bitwise OR operator is represented by a single pipe character (|) and also works on two numbers. Bitwise OR follows the rules in this truth table:

BIT FROM FIRST NUMBER	BIT FROM SECOND NUMBER	RESULT
1	1	1
1	0	1
0	1	1
0	0	0

A bitwise OR operation returns 1 if at least one bit is 1. It returns 0 only if both bits are 0.

Using the same example as for bitwise AND, if you want to OR the numbers 25 and 3 together, the code looks like this:

```
let result = 25 | 3;
console.log(result); // 27
```

The result of a bitwise OR between 25 and 3 is 27:

```
25 = 0000 0000 0000 0000 0000 0000 0001 1001
 3 = 0000 0000 0000 0000 0000 0000 0000 0011
-----
OR = 0000 0000 0000 0000 0000 0000 0001 1011
```

In each number, four bits are set to 1, so these are passed through to the result. The binary code 11011 is equal to 27.

Bitwise XOR

The bitwise XOR operator is represented by a caret (^) and also works on two values. Here is the truth table for bitwise XOR:

BIT FROM FIRST NUMBER	BIT FROM SECOND NUMBER	RESULT
1	1	0
1	0	1
0	1	1
0	0	0

Bitwise XOR is different from bitwise OR in that it returns 1 only when exactly one bit has a value of 1 (if both bits contain 1, it returns 0).

To XOR the numbers 25 and 3 together, use the following code:

```
let result = 25 ^ 3;
console.log(result); // 26
```

The result of a bitwise XOR between 25 and 3 is 26, as shown here:

```
25 = 0000 0000 0000 0000 0000 0000 0001 1001
 3 = 0000 0000 0000 0000 0000 0000 0000 0011
-----
XOR = 0000 0000 0000 0000 0000 0000 0001 1010
```

Four bits in each number are set to 1; however, the first bit in both numbers is 1, so that becomes 0 in the result. All of the other 1s have no corresponding 1 in the other number, so they are passed directly through to the result. The binary code 11010 is equal to 26. (Note that this is one less than when performing bitwise OR on these numbers.)

Left Shift

The left shift is represented by two less-than signs (<<) and shifts all bits in a number to the left by the number of positions given. For example, if the number 2 (which is equal to 10 in binary) is shifted 5 bits to the left, the result is 64 (which is equal to 1000000 in binary), as shown here:

```
let oldValue = 2;           // equal to binary 10
let newValue = oldValue << 5; // equal to binary 1000000 which is decimal 64
```

Note that when the bits are shifted, five empty bits remain to the right of the number. The left shift fills these bits with 0s to make the result a complete 32-bit number (see Figure 3-2).

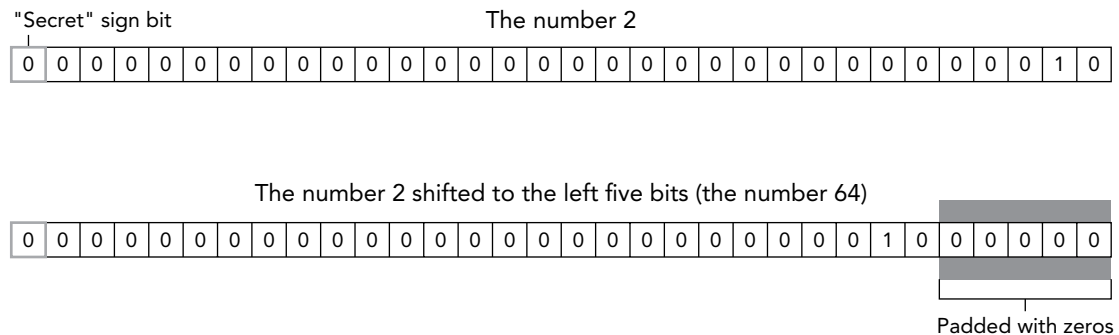

FIGURE 3-2:

Note that left shift preserves the sign of the number it's operating on. For instance, if -2 is shifted to the left by five spaces, it becomes -64 , not positive 64.

Signed Right Shift

The signed right shift is represented by two greater-than signs (>>) and shifts all bits in a 32-bit number to the right while preserving the sign (positive or negative). A signed right shift is the exact opposite of a left shift. For example, if 64 is shifted to the right five bits, it becomes 2:

```
let oldValue = 64;           // equal to binary 1000000
let newValue = oldValue >> 5; // equal to binary 10 which is decimal 2
```

Once again, when bits are shifted, the shift creates empty bits. This time, the empty bits occur at the left of the number but after the sign bit (see Figure 3-3). Once again, ECMAScript fills these empty bits with the value in the sign bit to create a complete number.

Unsigned Right Shift

The unsigned right shift is represented by three greater-than signs (>>>) and shifts all bits in a 32-bit number to the right. For numbers that are positive, the effect is the same as a signed right shift. Using the same example as for the signed-right-shift example, if 64 is shifted to the right five bits, it becomes 2:

```
let oldValue = 64;           // equal to binary 1000000
let newValue = oldValue >>> 5; // equal to binary 10 which is decimal 2
```

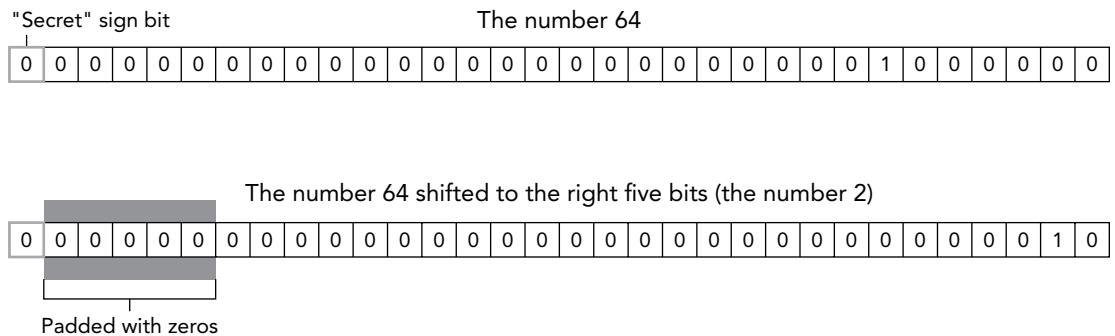

FIGURE 3-3:

For numbers that are negative, however, something quite different happens. Unlike signed right shift, the empty bits get filled with zeros regardless of the sign of the number. For positive numbers, it has the same effect as a signed right shift; for negative numbers, the result is quite different. The unsigned-right-shift operator considers the binary representation of the negative number to be representative of a positive number instead. Because the negative number is the two’s complement of its absolute value, the number becomes very large, as you can see in the following example:

```
let oldValue = -64; // equal to binary 11111111111111111111111111000000
let newValue = oldValue >>> 5; // equal to decimal 134217726
```

When an unsigned right shift is used to shift `-64` to the right by five bits, the result is `134217726`. This happens because the binary representation of `-64` is `111111111111111111111111000000`, but because the unsigned right shift treats this as a positive number, it considers the value to be `4294967232`. When this value is shifted to the right by five bits, it becomes `000001111111111111111111111111110`, which is `134217726`.

Boolean Operators

Almost as important as equality operators, Boolean operators are what make a programming language function. Without the capability to test relationships between two values, statements such as `if...else` and loops wouldn’t be useful. There are three Boolean operators: NOT, AND, and OR.

Logical NOT

The logical NOT operator is represented by an exclamation point (`!`) and may be applied to any value in ECMAScript. This operator always returns a Boolean value, regardless of the data type it’s used on. The logical NOT operator first converts the operand to a Boolean value and then negates it, meaning that the logical NOT behaves in the following ways:

- If the operand is an object, `false` is returned.
- If the operand is an empty string, `true` is returned.
- If the operand is a nonempty string, `false` is returned.
- If the operand is the number 0, `true` is returned.

- If the operand is any number other than 0 (including `Infinity`), `false` is returned.
- If the operand is `null`, `true` is returned.
- If the operand is `NaN`, `true` is returned.
- If the operand is `undefined`, `true` is returned.

The following example illustrates this behavior:

```
console.log(!false); // true
console.log(!"blue"); // false
console.log(!0); // true
console.log(!NaN); // true
console.log(!""); // true
console.log(!12345); // false
```

The logical NOT operator can also be used to convert a value into its Boolean equivalent. By using two NOT operators in a row, you can effectively simulate the behavior of the `Boolean()` casting function. The first NOT returns a Boolean value no matter what operand it is given. The second NOT negates that Boolean value and so gives the `true` Boolean value of a variable. The end result is the same as using the `Boolean()` function on a value, as shown here:

```
console.log(!!"blue"); // true
console.log(!!0); // false
console.log(!!NaN); // false
console.log(!!""); // false
console.log(!!12345); // true
```

Logical AND

The logical AND operator is represented by the double ampersand (`&&`) and is applied to two values, as in this example:

```
let result = true && false;
```

Logical AND behaves as described in the following truth table:

OPERAND 1	OPERAND 2	RESULT
true	true	true
true	false	false
false	true	false
false	false	false

Logical AND can be used with any type of operand, not just Boolean values. When either operand is not a primitive Boolean, logical AND does not always return a Boolean value; instead, it does one of the following:

- If the first operand is an object, then the second operand is always returned.
- If the second operand is an object, then the object is returned only if the first operand evaluates to `true`.

- If both operands are objects, then the second operand is returned.
- If either operand is `null`, then `null` is returned.
- If either operand is `NaN`, then `NaN` is returned.
- If either operand is `undefined`, then `undefined` is returned.

The logical AND operator is a short-circuited operation, meaning that if the first operand determines the result, the second operand is never evaluated. In the case of logical AND, if the first operand is `false`, no matter what the value of the second operand, the result can't be equal to `true`. Consider the following example:

```
let found = true;
let result = (found && someUndeclaredVariable); // error occurs here
console.log(result); // this line never executes
```

This code causes an error when the logical AND is evaluated, because the variable `someUndeclaredVariable` isn't declared. The value of the variable `found` is `true`, so the logical AND operator continued to evaluate the variable `someUndeclaredVariable`. When it did, an error occurred because `someUndeclaredVariable` is not declared and therefore cannot be used in a logical AND operation. If `found` is instead set to `false`, as in the following example, the error won't occur:

```
let found = false;
let result = (found && someUndeclaredVariable); // no error
console.log(result); // works
```

In this code, the `console.log` is displayed successfully. Even though the variable `someUndeclaredVariable` is `undefined`, it is never evaluated because the first operand is `false`. This means that the result of the operation must be `false`, so there is no reason to evaluate what's to the right of the `&&`. Always keep in mind short-circuiting when using logical AND.

Logical OR

The logical OR operator is represented by the double pipe (`||`) in ECMAScript, like this:

```
let result = true || false;
```

Logical OR behaves as described in the following truth table:

OPERAND 1	OPERAND 2	RESULT
true	true	true
true	false	true
false	true	true
false	false	false

Just like logical AND, if either operand is not a Boolean, logical OR will not always return a Boolean value; instead, it does one of the following:

- If the first operand is an object, then the first operand is returned.
- If the first operand evaluates to `false`, then the second operand is returned.

- If both operands are objects, then the first operand is returned.
- If both operands are `null`, then `null` is returned.
- If both operands are `NaN`, then `NaN` is returned.
- If both operands are `undefined`, then `undefined` is returned.

Also like the logical AND operator, the logical OR operator is short-circuited. In this case, if the first operand evaluates to `true`, the second operand is not evaluated. Consider this example:

```
let found = true;
let result = (found || someUndeclaredVariable); // no error
console.log(result); // works
```

As with the previous example, the variable `someUndeclaredVariable` is `undefined`. However, because the variable `found` is set to `true`, the variable `someUndeclaredVariable` is never evaluated and thus the output is `"true"`. If the value of `found` is changed to `false`, an error occurs, as in the following example:

```
let found = false;
let result = (found || someUndeclaredVariable); // error occurs here
console.log(result); // this line never executes
```

You can also use this behavior to avoid assigning a `null` or `undefined` value to a variable. Consider the following:

```
let myObject = preferredObject || backupObject;
```

In this example, the variable `myObject` will be assigned one of two values. The `preferredObject` variable contains the value that is preferred if it's available, whereas the `backupObject` variable contains the backup value if the preferred one isn't available. If `preferredObject` isn't `null`, then it's assigned to `myObject`; if it is `null`, then `backupObject` is assigned to `myObject`. This pattern is used very frequently in ECMAScript for variable assignment and is used throughout this book.

Multiplicative Operators

There are three multiplicative operators in ECMAScript: multiply, divide, and modulus. These operators work in a manner similar to their counterparts in languages such as Java, C, and Perl, but they also include some automatic type conversions when dealing with nonnumeric values. If either of the operands for a multiplication operation isn't a number, it is converted to a number behind the scenes using the `Number()` casting function. This means that an empty string is treated as 0, and the Boolean value of `true` is treated as 1.

Multiply

The multiply operator is represented by an asterisk (*) and is used, as one might suspect, to multiply two numbers. The syntax is the same as in C, as shown here:

```
let result = 34 * 56;
```

However, the multiply operator also has the following unique behaviors when dealing with special values:

- If the operands are numbers, regular arithmetic multiplication is performed, meaning that two positives or two negatives equal a positive, whereas operands with different signs yield a negative. If the result cannot be represented by ECMAScript, either `Infinity` or `-Infinity` is returned.
- If either operand is `NaN`, the result is `NaN`.
- If `Infinity` is multiplied by 0, the result is `NaN`.
- If `Infinity` is multiplied by any finite number other than 0, the result is either `Infinity` or `-Infinity`, depending on the sign of the second operand.
- If `Infinity` is multiplied by `Infinity`, the result is `Infinity`.
- If either operand isn't a number, it is converted to a number behind the scenes using `Number()` and then the other rules are applied.

Divide

The divide operator is represented by a slash (/) and divides the first operand by the second operand, as shown here:

```
let result = 66 / 11;
```

The divide operator, like the multiply operator, has special behaviors for special values. They are as follows:

- If the operands are numbers, regular arithmetic division is performed, meaning that two positives or two negatives equal a positive, whereas operands with different signs yield a negative. If the result can't be represented in ECMAScript, it returns either `Infinity` or `-Infinity`.
- If either operand is `NaN`, the result is `NaN`.
- If `Infinity` is divided by `Infinity`, the result is `NaN`.
- If zero is divided by zero, the result is `NaN`.
- If a nonzero finite number is divided by zero, the result is either `Infinity` or `-Infinity`, depending on the sign of the first operand.
- If `Infinity` is divided by any number, the result is either `Infinity` or `-Infinity`, depending on the sign of the second operand.
- If either operand isn't a number, it is converted to a number behind the scenes using `Number()` and then the other rules are applied.

Modulus

The modulus (remainder) operator is represented by a percent sign (%) and is used in the following way:

```
let result = 26 % 5; // equal to 1
```

Just like the other multiplicative operators, the modulus operator behaves differently for special values, as follows:

- If the operands are numbers, regular arithmetic division is performed, and the remainder of that division is returned.
- If the dividend is an infinite number and the divisor is a finite number, the result is NaN.
- If the dividend is a finite number and the divisor is 0, the result is NaN.
- If Infinity is divided by Infinity, the result is NaN.
- If the dividend is a finite number and the divisor is an infinite number, then the result is the dividend.
- If the dividend is zero and the divisor is nonzero, the result is zero.
- If either operand isn't a number, it is converted to a number behind the scenes using Number() and then the other rules are applied.

Exponentiation Operator

New in ECMAScript 7, Math.pow() now gets its own ** operator, which behaves identically.

```
console.log(Math.pow(3, 2)); // 9
console.log(3 ** 2); // 9

console.log(Math.pow(16, 0.5)); // 4
console.log(16** 0.5); // 4
```

What's more, the operator also gets its own exponentiate assignment operator, **=, which performs the exponentiation and subsequent assignment of the result:

```
let squared = 3;
squared **= 2;
console.log(squared); // 9

let sqrt = 16;
sqrt **= 0.5;
console.log(sqrt); // 4
```

Additive Operators

The additive operators, add and subtract, are typically the simplest mathematical operators in programming languages. In ECMAScript, however, a number of special behaviors are associated with each operator. As with the multiplicative operators, conversions occur behind the scenes for different data types. For these operators, however, the rules aren't as straightforward.

Add

The add operator (+) is used just as one would expect, as shown in the following example:

```
let result = 1 + 2;
```

If the two operands are numbers, they perform an arithmetic add and return the result according to the following rules:

- If either operand is NaN, the result is NaN.
- If Infinity is added to Infinity, the result is Infinity.
- If -Infinity is added to -Infinity, the result is -Infinity.
- If Infinity is added to -Infinity, the result is NaN.
- If +0 is added to +0, the result is +0.
- If -0 is added to +0, the result is +0.
- If -0 is added to -0, the result is -0.

If, however, one of the operands is a string, then the following rules apply:

- If both operands are strings, the second string is concatenated to the first.
- If only one operand is a string, the other operand is converted to a string and the result is the concatenation of the two strings.

If either operand is an object, number, or Boolean, its `toString()` method is called to get a string value and then the previous rules regarding strings are applied. For `undefined` and `null`, the `String()` function is called to retrieve the values "undefined" and "null", respectively.

Consider the following:

```
let result1 = 5 + 5;    // two numbers
console.log(result1);  // 10
let result2 = 5 + "5"; // a number and a string
console.log(result2);  // "55"
```

This code illustrates the difference between the two modes for the add operator. Normally, `5 + 5` equals 10 (a number value), as illustrated by the first two lines of code. However, if one of the operands is changed to a string, "5", the result becomes "55" (which is a primitive string value) because the first operand gets converted to "5" as well.

One of the most common mistakes in ECMAScript is being unaware of the data types involved with an addition operation. Consider the following:

```
let num1 = 5;
let num2 = 10;
let message = "The sum of 5 and 10 is " + num1 + num2;
console.log(message); // "The sum of 5 and 10 is 510"
```

In this example, the message variable is filled with a string that is the result of two addition operations. One might expect the final string to be "The sum of 5 and 10 is 15"; however, it actually ends up as "The sum of 5 and 10 is 510". This happens because each addition is done separately. The first combines a string with a number (5), which results in a string. The second takes that result (a string) and adds a number (10), which also results in a string. To perform the arithmetic calculation and then append that to the string, just add some parentheses like this:

```
let num1 = 5;
let num2 = 10;
let message = "The sum of 5 and 10 is " + (num1 + num2);
console.log(message); // "The sum of 5 and 10 is 15"
```

Here, the two number variables are surrounded by parentheses, which instruct the interpreter to calculate its result before adding it to the string. The resulting string is "The sum of 5 and 10 is 15".

Subtract

The subtract operator (-) is another that is used quite frequently. Here's an example:

```
let result = 2 - 1;
```

Just like the add operator, the subtract operator has special rules to deal with the variety of type conversions present in ECMAScript. They are as follows:

- If the two operands are numbers, perform arithmetic subtract and return the result.
- If either operand is `NaN`, the result is `NaN`.
- If `Infinity` is subtracted from `Infinity`, the result is `NaN`.
- If `-Infinity` is subtracted from `-Infinity`, the result is `NaN`.
- If `-Infinity` is subtracted from `Infinity`, the result is `Infinity`.
- If `Infinity` is subtracted from `-Infinity`, the result is `-Infinity`.
- If `+0` is subtracted from `+0`, the result is `+0`.
- If `-0` is subtracted from `+0`, the result is `-0`.
- If `-0` is subtracted from `-0`, the result is `+0`.
- If either operand is a string, a Boolean, `null`, or `undefined`, it is converted to a number (using `Number()` behind the scenes) and the arithmetic is calculated using the previous rules. If that conversion results in `NaN`, then the result of the subtraction is `NaN`.
- If either operand is an object, its `valueOf()` method is called to retrieve a numeric value to represent it. If that value is `NaN`, then the result of the subtraction is `NaN`. If the object doesn't have `valueOf()` defined, then `toString()` is called and the resulting string is converted into a number.

The following are some examples of these behaviors:

```
let result1 = 5 - true; // 4 because true is converted to 1
let result2 = NaN - 1; // NaN
let result3 = 5 - 3; // 2
```

```
let result4 = 5 - ""; // 5 because "" is converted to 0
let result5 = 5 - "2"; // 3 because "2" is converted to 2
let result6 = 5 - null; // 5 because null is converted to 0
```

Relational Operators

The less-than (<), greater-than (>), less-than-or-equal-to (<=), and greater-than-or-equal-to (>=) relational operators perform comparisons between values in the same way that you learned in math class. Each of these operators returns a Boolean value, as in this example:

```
let result1 = 5 > 3; // true
let result2 = 5 < 3; // false
```

As with other operators in ECMAScript, there are some conversions and other oddities that happen when using different data types. They are as follows:

- If the operands are numbers, perform a numeric comparison.
- If the operands are strings, compare the character codes of each corresponding character in the string.
- If one operand is a number, convert the other operand to a number and perform a numeric comparison.
- If an operand is an object, call `valueOf()` and use its result to perform the comparison according to the previous rules. If `valueOf()` is not available, call `toString()` and use that value according to the previous rules.
- If an operand is a Boolean, convert it to a number and perform the comparison.

When a relational operator is used on two strings, an interesting behavior occurs. Many expect that less-than means “alphabetically before” and greater-than means “alphabetically after,” but this is not the case. For strings, each of the first string’s character codes is numerically compared against the character codes in a corresponding location in the second string. After this comparison is complete, a Boolean value is returned. The problem here is that the character codes of uppercase letters are all lower than the character codes of lowercase letters, meaning that you can run into situations like this:

```
let result = "Brick" < "alphabet"; // true
```

In this example, the string `"Brick"` is considered to be less than the string `"alphabet"` because the letter *B* has a character code of 66 and the letter *a* has a character code of 97. To force a true alphabetic result, you must convert both operands into a common case (upper or lower) and then compare like this:

```
let result = "Brick".toLowerCase() < "alphabet".toLowerCase(); // false
```

Converting both operands to lowercase ensures that `"alphabet"` is correctly identified as alphabetically before `"Brick"`.

Another sticky situation occurs when comparing numbers that are strings, such as in this example:

```
let result = "23" < "3"; // true
```

This code returns `true` when comparing the string `"23"` to `"3"`. Because both operands are strings, they are compared by their character codes (the character code for `"2"` is 50; the character code for

"3" is 51). If, however, one of the operands is changed to a number as in the following example, the result makes more sense:

```
let result = "23" < 3; // false
```

Here, the string "23" is converted into the number 23 and then compared to 3, giving the expected result. Whenever a number is compared to a string, the string is converted into a number and then numerically compared to the other number. This works well for cases like the previous example, but what if the string can't be converted into a number? Consider this example:

```
let result = "a" < 3; // false because "a" becomes NaN
```

The letter "a" can't be meaningfully converted into a number, so it becomes `NaN`. As a rule, the result of any relational operation with `NaN` is `false`, which is interesting when considering the following:

```
let result1 = NaN < 3; // false
let result2 = NaN >= 3; // false
```

In most comparisons, if a value is not less than another, it is always greater than or equal to it. When using `NaN`, however, both comparisons return `false`.

Equality Operators

Determining whether two variables are equivalent is one of the most important operations in programming. This is fairly straightforward when dealing with strings, numbers, and Boolean values, but the task gets a little complicated when you take objects into account. Originally ECMAScript's equal and not-equal operators performed conversions into like types before doing a comparison. The question of whether these conversions should, in fact, take place was then raised. The end result was for ECMAScript to provide two sets of operators: *equal* and *not equal* to perform conversion before comparison, and *identically equal* and *not identically equal* to perform comparison without conversion.

Equal and Not Equal

The equal operator in ECMAScript is the double equal sign (`==`), and it returns `true` if the operands are equal. The not-equal operator is the exclamation point followed by an equal sign (`!=`), and it returns `true` if two operands are not equal. Both operators do conversions to determine if two operands are equal (often called *type coercion*).

When performing conversions, the equal and not-equal operators follow these basic rules:

- If an operand is a Boolean value, convert it into a numeric value before checking for equality. A value of `false` converts to 0, whereas a value of `true` converts to 1.
- If one operand is a string and the other is a number, attempt to convert the string into a number before checking for equality.
- If one of the operands is an object and the other is not, the `valueOf()` method is called on the object to retrieve a primitive value to compare according to the previous rules.

The operators also follow these rules when making comparisons:

- Values of `null` and `undefined` are equal.
- Values of `null` and `undefined` cannot be converted into any other values for equality checking.
- If either operand is `NaN`, the equal operator returns `false` and the not-equal operator returns `true`. Important note: even if both operands are `NaN`, the equal operator returns `false` because, by rule, `NaN` is not equal to `NaN`.
- If both operands are objects, then they are compared to see if they are the same object. If both operands point to the same object, then the equal operator returns `true`. Otherwise, the two are not equal.

The following table lists some special cases and their results:

EXPRESSION	VALUE
<code>null == undefined</code>	<code>true</code>
<code>"NaN" == NaN</code>	<code>false</code>
<code>5 == NaN</code>	<code>false</code>
<code>NaN == NaN</code>	<code>false</code>
<code>NaN != NaN</code>	<code>true</code>
<code>false == 0</code>	<code>true</code>
<code>true == 1</code>	<code>true</code>
<code>true == 2</code>	<code>false</code>
<code>undefined == 0</code>	<code>false</code>
<code>null == 0</code>	<code>false</code>
<code>"5" == 5</code>	<code>true</code>

Identically Equal and Not Identically Equal

The identically equal and not identically equal operators do the same thing as equal and not equal, except that they do not convert operands before testing for equality. The identically equal operator is represented by three equal signs (`===`) and returns `true` only if the operands are equal without conversion, as in this example:

```
let result1 = ("55" == 55); // true - equal because of conversion
let result2 = ("55" === 55); // false - not equal because different data types
```

In this code, the first comparison uses the equal operator to compare the string "55" and the number 55, which returns `true`. As mentioned previously, this happens because the string "55" is converted to the number 55 and then compared with the other number 55. The second comparison uses the identically equal operator to compare the string and the number without conversion, and of course, a string isn't equal to a number, so this outputs `false`.

The not identically equal operator is represented by an exclamation point followed by two equal signs (`!==`) and returns `true` only if the operands are not equal without conversion. For example:

```
let result1 = ("55" != 55); // false - equal because of conversion
let result2 = ("55" !== 55); // true - not equal because different data types
```

Here, the first comparison uses the not-equal operator, which converts the string "55" to the number 55, making it equal to the second operand, also the number 55. Therefore, this evaluates to `false` because the two are considered equal. The second comparison uses the not identically equal operator. It helps to think of this operation as saying, "Is the string 55 different from the number 55?" The answer to this is yes (`true`).

Keep in mind that while `null == undefined` is `true` because they are similar values, `null === undefined` is `false` because they are not the same type.

NOTE *Because of the type conversion issues with the equal and not-equal operators, it is recommended to use identically equal and not identically equal instead. This helps to maintain data type integrity throughout your code.*

Conditional Operator

The conditional operator is one of the most versatile in ECMAScript, and it takes on the same form as in Java, which is as follows:

```
variable = boolean_expression ? true_value : false_value;
```

This basically allows a conditional assignment to a variable depending on the evaluation of the `boolean_expression`. If it's `true`, then `true_value` is assigned to the variable; if it's `false`, then `false_value` is assigned to the variable, as in this instance:

```
let max = (num1 > num2) ? num1 : num2;
```

In this example, `max` is to be assigned the number with the highest value. The expression states that if `num1` is greater than `num2`, then `num1` is assigned to `max`. If, however, the expression is `false` (meaning that `num1` is less than or equal to `num2`), then `num2` is assigned to `max`.

Assignment Operators

Simple assignment is done with the equal sign (`=`) and simply assigns the value on the right to the variable on the left, as shown in the following example:

```
let num = 10;
```

Compound assignment is done with one of the multiplicative, additive, or bitwise-shift operators followed by an equal sign (=). These assignments are designed as shorthand for such common situations as this:

```
let num = 10;
num = num + 10;
```

The second line of code can be replaced with a compound assignment:

```
let num = 10;
num += 10;
```

Compound-assignment operators exist for each of the major mathematical operations and a few others as well. They are as follows:

- Multiply/assign (*=)
- Divide/assign (/=)
- Modulus/assign (%=)
- Add/assign (+=)
- Subtract/assign (-=)
- Left shift/assign (<<=)
- Signed right shift/assign (>>=)
- Unsigned right shift/assign (>>>=)

These operators are designed specifically as shorthand ways of achieving operations. They do not represent any performance improvement.

Comma Operator

The comma operator allows execution of more than one operation in a single statement, as illustrated here:

```
let num1 = 1, num2 = 2, num3 = 3;
```

Most often, the comma operator is used in the declaration of variables; however, it can also be used to assign values. When used in this way, the comma operator always returns the last item in the expression, as in the following example:

```
let num = (5, 1, 4, 8, 0); // num becomes 0
```

In this example, `num` is assigned the value of 0 because it is the last item in the expression. There aren't many times when commas are used in this way; however, it is helpful to understand that this behavior exists.

STATEMENTS

ECMA-262 describes several statements (also called *flow-control statements*). Essentially, statements define most of the syntax of ECMAScript and typically use one or more keywords to accomplish a given task. Statements can be simple, such as telling a function to exit, or complicated, such as specifying a number of commands to be executed repeatedly.

The if Statement

One of the most frequently used statements in most programming languages is the `if` statement. The `if` statement has the following syntax:

```
if (condition) statement1 else statement2
```

The condition can be any expression; it doesn't even have to evaluate to an actual Boolean value. ECMAScript automatically converts the result of the expression into a Boolean by calling the `Boolean()` casting function on it. If the condition evaluates to `true`, `statement1` is executed; if the condition evaluates to `false`, `statement2` is executed. Each of the statements can be either a single line or a code block (a group of code lines enclosed within braces). Consider this example:

```
if (i > 25)
  console.log("Greater than 25."); // one-line statement
else {
  console.log("Less than or equal to 25."); // block statement
}
```

It's considered best coding practice to always use block statements, even if only one line of code is to be executed. Doing so can avoid confusion about what should be executed for each condition.

You can also chain `if` statements together like so:

```
if (condition1) statement1 else if (condition2) statement2 else statement3
```

Here's an example:

```
if (i > 25) {
  console.log("Greater than 25.");
} else if (i < 0) {
  console.log("Less than 0.");
} else {
  console.log("Between 0 and 25, inclusive.");
}
```

The do-while Statement

The `do-while` statement is a post-test loop, meaning that the escape condition is evaluated only after the code inside the loop has been executed. The body of the loop is always executed at least once before the expression is evaluated. Here's the syntax:

```
do {
  statement
} while (expression);
```

And here's an example of its usage:

```
let i = 0;
do {
  i += 2;
} while (i < 10);
```

In this example, the loop continues as long as `i` is less than 10. The variable starts at 0 and is incremented by two each time through the loop.

NOTE *Post-test loops such as this are most often used when the body of the loop should be executed at least once before exiting.*

The while Statement

The `while` statement is a pretest loop. This means the escape condition is evaluated before the code inside the loop has been executed. Because of this, it is possible that the body of the loop is never executed. Here's the syntax:

```
while(expression) statement
```

And here's an example of its usage:

```
let i = 0;
while (i < 10) {
  i += 2;
}
```

In this example, the variable `i` starts out equal to 0 and is incremented by two each time through the loop. As long as the variable is less than 10, the loop will continue.

The for Statement

The `for` statement is also a pretest loop with the added capabilities of variable initialization before entering the loop and defining postloop code to be executed. Here's the syntax:

```
for (initialization; expression; post-loop-expression) statement
```

And here's an example of its usage:

```
let count = 10;
for (let i = 0; i < count; i++) {
  console.log(i);
}
```

This code defines a variable `i` that begins with the value 0. The `for` loop is entered only if the conditional expression (`i < count`) evaluates to `true`, making it possible that the body of the code might

not be executed. If the body is executed, the postloop expression is also executed, iterating the variable `i`. This `for` loop is the same as the following:

```
let count = 10;
let i = 0;
while (i < count) {
  console.log(i);
  i++;
}
```

Nothing can be done with a `for` loop that can't be done using a `while` loop. The `for` loop simply encapsulates the loop-related code into a single location.

It's important to note that there's no need to use the variable declaration keyword inside the `for` loop initialization. However, the overwhelming majority of the time you will find that the iterator variable is not useful after the loop completes. In these cases, the cleanest implementation is to use a `let` declaration inside the loop initialization to declare the iterator variable because its scope will be limited to only the loop itself.

The initialization, control expression, and postloop expression are all optional. You can create an infinite loop by omitting all three, like this:

```
for (;;) { // infinite loop
  doSomething();
}
```

Including only the control expression effectively turns a `for` loop into a `while` loop, as shown here:

```
let count = 10;
let i = 0;
for (; i < count; ) {
  console.log(i);
  i++;
}
```

This versatility makes the `for` statement one of the most used in the language.

The for-in Statement

The `for-in` statement is a strict iterative statement. It is used to enumerate the non-symbol keyed properties of an object. Here's the syntax:

```
for (property in expression) statement
```

And here's an example of its usage:

```
for (const propName in window) {
  document.write(propName);
}
```

Here, the `for-in` statement is used to display all the properties of the BOM `window` object. Each time through the loop, the `propName` variable is filled with the name of a property that exists on the `window` object. This continues until all of the available properties have been enumerated. As with the `for` statement, the `const` operator in the control statement is not necessary but is recommended for ensuring the use of a local variable that will not be altered.

Object properties in ECMAScript are unordered, so the order in which property names are returned in a `for-in` statement cannot necessarily be predicted. All enumerable properties will be returned once, but the order may differ across browsers.

Note that the `for-in` statement simply doesn't execute the body of the loop if the variable representing the object to iterate over is `null` or `undefined`.

The for-of Statement

The `for-of` statement is a strict iterative statement. It is used to loop through elements in an iterable object. Here's the syntax:

```
for (property of expression) statement
```

And here's an example of its usage:

```
for (const el in [2,4,6,8]) {  
  document.write(el);  
}
```

Here, the `for-of` statement is used to display all the elements inside the four-element array. This continues until each element in the array has been looped over. As with the `for` statement, the `const` operator in the control statement is not necessary but is recommended for ensuring the use of a local variable that will not be altered.

The `for-of` loop will iterate in the order that the iterable produces values via its `next()` method. This is covered in-depth in the Iterators and Generators chapter.

Note that the `for-of` statement will throw an error if the entity that it is attempting to iterate over does not support iteration.

NOTE *In ES2018, the for-of statement is extended as a for-await-of loop to support async iterables which produce promises. This is covered in Appendix A.*

Labeled Statements

It is possible to label statements for later use with the following syntax:

```
label: statement
```

Here's an example:

```
start: for (let i = 0; i < count; i++) {  
  console.log(i);  
}
```

In this example, the label `start` can be referenced later by using the `break` or `continue` statement. Labeled statements are typically used with nested loops.

The break and continue Statements

The `break` and `continue` statements provide stricter control over the execution of code in a loop. The `break` statement exits the loop immediately, forcing execution to continue with the next statement after the loop. The `continue` statement, on the other hand, exits the loop immediately, but execution continues from the top of the loop. Here's an example:

```
let num = 0;

for (let i = 1; i < 10; i++) {
  if (i % 5 == 0) {
    break;
  }
  num++;
}

console.log(num); // 4
```

In this code, the `for` loop increments the variable `i` from 1 to 10. In the body of a loop, an `if` statement checks to see if the value of `i` is evenly divisible by 5 (using the modulus operator). If so, the `break` statement is executed and the loop is exited. The `num` variable starts out at 0 and indicates the number of times the loop has been executed. After the `break` statement has been hit, the next line of code to be executed is the `console.log`, which displays 4. The number of times the loop has been executed is four because when `i` equals 5, the `break` statement causes the loop to be exited before `num` can be incremented. A different effect can be seen if `break` is replaced with `continue` like this:

```
let num = 0;

for (let i = 1; i < 10; i++) {
  if (i % 5 == 0) {
    continue;
  }
  num++;
}

console.log(num); // 8
```

Here, the `console.log` displays 8, the number of times the loop has been executed. When `i` reaches a value of 5, the loop is exited before `num` is incremented, but execution continues with the next iteration, when the value is 6. The loop then continues until its natural completion, when `i` is 10. The final value of `num` is 8 instead of 9 because one increment didn't occur due to the `continue` statement.

Both the `break` and `continue` statements can be used in conjunction with labeled statements to return to a particular location in the code. This is typically used when there are loops inside of loops, as in the following example:

```
let num = 0;

outermost:
for (let i = 0; i < 10; i++) {
  for (let j = 0; j < 10; j++) {
    if (i == 5 && j == 5) {
      break outermost;
    }
  }
}
```

```

        num++;
    }
}

console.log(num); // 55

```

In this example, the `outermost` label indicates the first `for` statement. Each loop normally executes 10 times, meaning that the `num++` statement is normally executed 100 times and, consequently, `num` should be equal to 100 when the execution is complete. The `break` statement here is given one argument: the label to break to. Adding the label allows the `break` statement to break not just out of the inner `for` statement (using the variable `j`) but also out of the outer `for` statement (using the variable `i`). Because of this, `num` ends up with a value of 55, because execution is halted when both `i` and `j` are equal to 5. The `continue` statement can be used in the same way, as shown in the following example:

```

let num = 0;

outermost:
for (let i = 0; i < 10; i++) {
    for (let j = 0; j < 10; j++) {
        if (i == 5 && j == 5) {
            continue outermost;
        }
        num++;
    }
}

console.log(num); // 95

```

In this case, the `continue` statement forces execution to continue—not in the inner loop but in the outer loop. When `j` is equal to 5, `continue` is executed, which means that the inner loop misses five iterations, leaving `num` equal to 95.

Using labeled statements in conjunction with `break` and `continue` can be very powerful but can cause debugging problems if overused. Always use descriptive labels and try not to nest more than a few loops.

The with Statement

The `with` statement sets the scope of the code within a particular object. The syntax is as follows:

```
with (expression) statement;
```

The `with` statement was created as a convenience for times when a single object was being coded to over and over again, as in this example:

```

let qs = location.search.substring(1);
let hostName = location.hostname;
let url = location.href;

```

Here, the `location` object is used on every line. This code can be rewritten using the `with` statement as follows:

```

with(location) {
    let qs = search.substring(1);
    let hostName = hostname;
    let url = href;
}

```

In this rewritten version of the code, the `with` statement is used in conjunction with the `location` object. This means that each variable inside the statement is first considered to be a local variable. If it's not found to be a local variable, the `location` object is searched to see if it has a property of the same name. If so, then the variable is evaluated as a property of `location`.

In strict mode, the `with` statement is not allowed and is considered a syntax error.

WARNING *It is widely considered a poor practice to use the `with` statement in production code because of its negative performance impact and the difficulty in debugging code contained in the `with` statement.*

The switch Statement

Closely related to the `if` statement is the `switch` statement, another flow-control statement adopted from other languages. The syntax for the `switch` statement in ECMAScript closely resembles the syntax in other C-based languages, as you can see here:

```
switch (expression) {
  case value1:
    statement
    break;
  case value2:
    statement
    break;
  case value3:
    statement
    break;
  case value4:
    statement
    break;
  default:
    statement
}
```

Each case in a `switch` statement says, “If the expression is equal to the value, execute the statement.” The `break` keyword causes code execution to jump out of the `switch` statement. Without the `break` keyword, code execution falls through the original case into the following one. The `default` keyword indicates what is to be done if the expression does not evaluate to one of the cases. (In effect, it is an `else` statement.)

Essentially, the `switch` statement prevents a developer from having to write something like this:

```
if (i == 25) {
  console.log("25");
} else if (i == 35) {
  console.log("35");
} else if (i == 45) {
  console.log("45");
} else {
  console.log("Other");
}
```

The equivalent `switch` statement is as follows:

```
switch (i) {
  case 25:
    console.log("25");
    break;
  case 35:
    console.log("35");
    break;
  case 45:
    console.log("45");
    break;
  default:
    console.log("Other");
}
```

It's best to always put a `break` statement after each case to avoid having cases fall through into the next one. If you need a case statement to fall through, include a comment indicating that the omission of the `break` statement is intentional, such as this:

```
switch (i) {
  case 25:
    /* falls through */
  case 35:
    console.log("25 or 35");
    break;
  case 45:
    console.log("45");
    break;
  default:
    console.log("Other");
}
```

Although the `switch` statement was borrowed from other languages, it has some unique characteristics in ECMAScript. First, the `switch` statement works with all data types (in many languages it works only with numbers), so it can be used with strings and even with objects. Second, the case values need not be constants; they can be variables and even expressions. Consider the following example:

```
switch ("hello world") {
  case "hello" + " world":
    console.log("Greeting was found.");
    break;
  case "goodbye":
    console.log("Closing was found.");
    break;
  default:
    console.log("Unexpected message was found.");
}
```

In this example, a string value is used in a `switch` statement. The first case is actually an expression that evaluates a string concatenation. Because the result of this concatenation is equal to the `switch`

argument, the `console.log` displays "Greeting was found." The ability to have case expressions also allows you to do things like this:

```
let num = 25;
switch (true) {
  case num < 0:
    console.log("Less than 0.");
    break;
  case num >= 0 && num <= 10:
    console.log("Between 0 and 10.");
    break;
  case num > 10 && num <= 20:
    console.log("Between 10 and 20.");
    break;
  default:
    console.log("More than 20.");
}
```

Here, a variable `num` is defined outside the `switch` statement. The expression passed into the `switch` statement is `true` because each case is a conditional that will return a Boolean value. Each case is evaluated, in order, until a match is found or until the `default` statement is encountered (which is the case here).

NOTE *The `switch` statement compares values using the identically equal operator, so no type coercion occurs (for example, the string "10" is not equal to the number 10).*

FUNCTIONS

Functions are the core of any language because they allow the encapsulation of statements that can be run anywhere and at any time. Functions in ECMAScript are declared using the `function` keyword, followed by a set of arguments and then the body of the function.

NOTE *In-depth function coverage can be found in the Functions chapter.*

The basic function syntax is as follows:

```
function functionName(arg0, arg1, ..., argN) {
  statements
}
```

Here's an example:

```
function sayHi(name, message) {
  console.log("Hello " + name + ", " + message);
}
```

This function can then be called by using the function name, followed by the function arguments enclosed in parentheses (and separated by commas, if there are multiple arguments). The code to call the `sayHi()` function looks like this:

```
sayHi("Nicholas", "how are you today?");
```

The output of this function call is, "Hello Nicholas, how are you today?" The named arguments `name` and `message` are used as part of a string concatenation that is ultimately displayed in an `console.log`.

Functions in ECMAScript need not specify whether they return a value. Any function can return a value at any time by using the `return` statement followed by the value to return. Consider this example:

```
function sum(num1, num2) {  
  return num1 + num2;  
}
```

The `sum()` function adds two values together and returns the result. Note that aside from the `return` statement, there is no special declaration indicating that the function returns a value. This function can be called using the following:

```
const result = sum(5, 10);
```

Keep in mind that a function stops executing and exits immediately when it encounters the `return` statement. Therefore, any code that comes after a `return` statement will never be executed.

For example:

```
function sum(num1, num2) {  
  return num1 + num2;  
  console.log("Hello world"); // never executed  
}
```

In this example, the `console.log` will never be displayed because it appears after the `return` statement.

It's also possible to have more than one `return` statement in a function, like this:

```
function diff(num1, num2) {  
  if (num1 < num2) {  
    return num2 - num1;  
  } else {  
    return num1 - num2;  
  }  
}
```

Here, the `diff()` function determines the difference between two numbers. If the first number is less than the second, it subtracts the first from the second; otherwise it subtracts the second from the first. Each branch of the code has its own `return` statement that does the correct calculation.

The `return` statement can also be used without specifying a return value. When used in this way, the function stops executing immediately and returns `undefined` as its value. This is typically used in functions that don't return a value to stop function execution early, as in the following example, where the `console.log` won't be displayed:

```
function sayHi(name, message) {  
  return;  
  console.log("Hello " + name + ", " + message); // never called  
}
```

NOTE *Best practices dictate that a function either always return a value or never return a value. Writing a function that sometimes returns a value causes confusion, especially during debugging.*

Strict mode places several restrictions on functions:

- No function can be named `eval` or `arguments`.
- No named parameter can be named `eval` or `arguments`.
- No two named parameters can have the same name.

If any of these occur, it's considered a syntax error and the code will not execute.

SUMMARY

The core language features of JavaScript are defined in ECMA-262 as a pseudolanguage named ECMAScript. ECMAScript contains all of the basic syntax, operators, data types, and objects necessary to complete basic computing tasks, though it provides no way to get input or to produce output. Understanding ECMAScript and its intricacies is vital to a complete understanding of JavaScript as implemented in web browsers. The following are some of the basic elements of ECMAScript:

- The basic data types in ECMAScript are Undefined, Null, Boolean, Number, String, and Symbol.
- Unlike other languages, there's no separate data type for integers versus floating-point values; the Number type represents all numbers.
- There is also a complex data type, Object, that is the base type for all objects in the language.
- A strict mode places restrictions on certain error-prone parts of the language.
- ECMAScript provides a lot of the basic operators available in C and other C-like languages, including arithmetic operators, Boolean operators, relational operators, equality operators, and assignment operators.
- The language features flow-control statements borrowed heavily from other languages, such as the `if` statement, the `for` statement, and the `switch` statement.

Functions in ECMAScript behave differently than functions in other languages:

- There is no need to specify the return value of the function because any function can return any value at any time.
- Functions that don't specify a return value actually return the special value `undefined`.

4

Variables, Scope, and Memory

WHAT'S IN THIS CHAPTER?

- Working with primitive and reference values in variables
- Understanding execution context
- Understanding garbage collection

WROX.COM DOWNLOADS FOR THIS CHAPTER

Please note that all the code examples for this chapter are available as a part of this chapter's code download on the book's website at www.wrox.com/go/projavascript4e on the Download Code tab.

The nature of variables in JavaScript, as defined in ECMA-262, is quite unique compared to that of other languages. Being loosely typed, a variable is literally just a name for a particular value at a particular time. Because there are no rules defining the type of data that a variable must hold, a variable's value and data type can change during the lifetime of a script. Though this is an interesting, powerful, and problematic feature, there are many more complexities related to variables.

PRIMITIVE AND REFERENCE VALUES

ECMAScript variables may contain two different types of data: primitive values and reference values. *Primitive values* are simple atomic pieces of data, while *reference values* are objects that may be made up of multiple values.

When a value is assigned to a variable, the JavaScript engine must determine if it's a primitive or a reference value. The six primitive types were discussed in the previous chapter: Undefined, Null, Boolean, Number, String, and Symbol. These variables are said to be accessed *by value*, because you are manipulating the actual value stored in the variable.

Reference values are objects stored in memory. Unlike other languages, JavaScript does not permit direct access of memory locations, so direct manipulation of the object's memory space is not allowed. When you manipulate an object, you're really working on a *reference* to that object rather than the actual object itself. For this reason, such values are said to be accessed *by reference*.

NOTE *In many languages, strings are represented by objects and are therefore considered to be reference types. ECMAScript breaks away from this tradition.*

Dynamic Properties

Primitive and reference values are defined similarly: a variable is created and assigned a value. What you can do with those values once they're stored in a variable, however, is quite different. When you work with reference values, you can add, change, or delete properties and methods at any time. Consider this example:

```
let person = new Object();
person.name = "Nicholas";
console.log(person.name); // "Nicholas"
```

Here, an object is created and stored in the variable `person`. Next, a property called `name` is added and assigned the string value of `"Nicholas"`. The new property is then accessible from that point on, until the object is destroyed or the property is explicitly removed.

Primitive values can't have properties added to them even though attempting to do so won't cause an error. Here's an example:

```
let name = "Nicholas";
name.age = 27;
console.log(name.age); // undefined
```

Here, a property called `age` is defined on the string `name` and assigned a value of `27`. On the very next line, however, the property is gone. Only reference values can have properties defined dynamically for later use.

Note that the instantiation of a primitive type can be accomplished using only the primitive literal form. If you were to use the `new` keyword, JavaScript will create an Object type, but one that behaves like a primitive. Here's an example to distinguish between the two:

```
let name1 = "Nicholas";
let name2 = new String("Matt");
name1.age = 27;
name2.age = 26;
console.log(name1.age); // undefined
```

```

console.log(name2.age); // 26
console.log(typeof name1); // string
console.log(typeof name2); // object

```

Copying Values

Aside from differences in how they are stored, primitive and reference values act differently when copied from one variable to another. When a primitive value is assigned from one variable to another, the value stored on the variable object is created and copied into the location for the new variable.

Consider the following example:

```

let num1 = 5;
let num2 = num1;

```

Here, `num1` contains the value of 5. When `num2` is initialized to `num1`, it also gets the value of 5. This value is completely separate from the one that is stored in `num1` because it's a copy of that value.

Each of these variables can now be used separately with no side effects. This process is diagrammed in Figure 4-1.

When a reference value is assigned from one variable to another, the value stored on the variable object is also copied into the location for the new variable. The difference is that this value is actually a pointer to an object stored on the heap. Once the operation is complete, two variables point to exactly the same object, so changes to one are reflected on the other, as in the following example:

```

let obj1 = new Object();
let obj2 = obj1;
obj1.name = "Nicholas";
console.log(obj2.name); // "Nicholas"

```

In this example, the variable `obj1` is filled with a new instance of an object. This value is then copied into `obj2`, meaning that both variables are now pointing to the same object. When the property `name` is set on `obj1`, it can later be accessed from `obj2` because they both point to the same object. Figure 4-2 shows the relationship between the variables on the variable object and the object on the heap.

Variable object before copy

num1	5 (Number type)

Variable object after copy

num2	5 (Number type)
num1	5 (Number type)

FIGURE 4-1

Argument Passing

All function arguments in ECMAScript are passed by value. This means that the value outside of the function is copied into an argument on the inside of the function the same way a value is copied from one variable to another. If the value is primitive, then it acts just like a primitive variable copy, and if the value is a reference, it acts just like a reference variable copy. This is often a point of confusion for developers because variables are accessed both by value and by reference, but arguments are passed only by value.

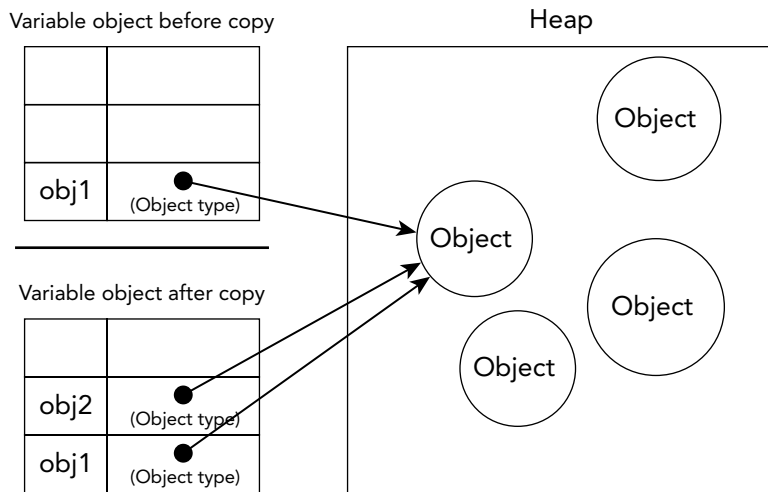

FIGURE 4-2

When an argument is passed by value, the value is copied into a local variable (a named argument and, in ECMAScript, a slot in the `arguments` object). When an argument is passed by reference, the location of the value in memory is stored into a local variable, which means that changes to the local variable are reflected outside of the function. (This is not possible in ECMAScript.) Consider the following example:

```
function addTen(num) {
  num += 10;
  return num;
}

let count = 20;
let result = addTen(count);
console.log(count); // 20 - no change
console.log(result); // 30
```

Here, the function `addTen()` has an argument, `num`, which is essentially a local variable. When called, the variable `count` is passed in as an argument. This variable has a value of 20, which is copied into the argument `num` for use inside of `addTen()`. Within the function, the argument `num` has its value changed by adding 10, but this doesn't change the original variable `count` that exists outside of the function. The argument `num` and the variable `count` do not recognize each other; they only happen to have the same value. If `num` had been passed by reference, then the value of `count` would have changed to 30 to reflect the change made inside the function. This fact is obvious when using primitive values such as numbers, but things aren't as clear when using objects. Take this, for example:

```
function setName(obj) {
  obj.name = "Nicholas";
}

let person = new Object();
setName(person);
console.log(person.name); // "Nicholas"
```

In this code, an object is created and stored in the variable `person`. This object is then passed into the `setName()` method, where it is copied into `obj`. Inside the function, `obj` and `person` both point to the same object. The result is that `obj` is accessing an object by reference, even though it was passed into the function by value. When the `name` property is set on `obj` inside the function, this change is reflected outside the function, because the object that it points to exists globally on the heap. Many developers incorrectly assume that when a local change to an object is reflected globally, that means an argument was passed by reference. To prove that objects are passed by value, consider the following modified code:

```
function setName(obj) {
  obj.name = "Nicholas";
  obj = new Object();
  obj.name = "Greg";
}

let person = new Object();
setName(person);
console.log(person.name); // "Nicholas"
```

The only change between this example and the previous one is that two lines have been added to `setName()` that redefine `obj` as a new object with a different name. When `person` is passed into `setName()`, its `name` property is set to "Nicholas". Then the variable `obj` is set to be a new object and its `name` property is set to "Greg". If `person` were passed by reference, then `person` would automatically be changed to point to the object whose name is "Greg". However, when `person.name` is accessed again, its value is "Nicholas", indicating that the original reference remained intact even though the argument's value changed inside the function. When `obj` is overwritten inside the function, it becomes a pointer to a local object. That local object is destroyed as soon as the function finishes executing.

NOTE *Think of function arguments in ECMAScript as nothing more than local variables.*

Determining Type

The `typeof` operator, introduced in the previous chapter, is the best way to determine if a variable is a primitive type. More specifically, it's the best way to determine if a variable is a string, number, Boolean, or undefined. If the value is an object or null, then `typeof` returns "object", as in this example:

```
let s = "Nicholas";
let b = true;
let i = 22;
let u;
let n = null;
let o = new Object();
```



```

console.log(typeof s); // string
console.log(typeof i); // number
console.log(typeof b); // boolean
console.log(typeof u); // undefined
console.log(typeof n); // object
console.log(typeof o); // object

```

Although `typeof` works well for primitive values, it's of little use for reference values. Typically, you don't care that a value is an object—what you really want to know is what type of object it is. To aid in this identification, ECMAScript provides the `instanceof` operator, which is used with the following syntax:

```
result = variable instanceof constructor
```

The `instanceof` operator returns `true` if the variable is an instance of the given reference type (identified by its prototype chain, as discussed in the *Objects, Classes, and Object-Oriented Programming* chapter). Consider this example:

```

console.log(person instanceof Object); // is the variable person an Object?
console.log(colors instanceof Array); // is the variable colors an Array?
console.log(pattern instanceof RegExp); // is the variable pattern a RegExp?

```

All reference values, by definition, are instances of `Object`, so the `instanceof` operator always returns `true` when used with a reference value and the `Object` constructor. Similarly, if `instanceof` is used with a primitive value, it will always return `false`, because primitives aren't objects.

NOTE *The `typeof` operator also returns "function" when used on a function. When used on a regular expression in Safari (through version 5) and Chrome (through version 7), `typeof` returns "function" because of an implementation detail. ECMA-262 specifies that any object implementing the internal `[[Call]]` method should return "function" from `typeof`. Since regular expressions implement this method in these browsers, `typeof` returns "function". In Internet Explorer and Firefox, `typeof` returns "object" for regular expressions.*

EXECUTION CONTEXT AND SCOPE

The concept of execution context, referred to as *context* for simplicity, is of the utmost importance in JavaScript. The execution context of a variable or function defines what other data it has access to, as well as how it should behave. Each execution context has an associated *variable object* upon which all of its defined variables and functions exist. This object is not accessible by code but is used behind the scenes to handle data.

The global execution context is the outermost one. Depending on the host environment for an ECMAScript implementation, the object representing this context may differ. In web browsers, the global context is said to be that of the `window` object (discussed in the *Browser Object Model* chapter), so all global variables and functions defined with `var` are created as properties and methods on the `window` object. Declarations using `let` and `const` at the top level are not defined in the global context, but they are resolved identically on the scope chain. When an execution context has executed

all of its code, it is destroyed, taking with it all of the variables and functions defined within it (the global context isn't destroyed until the application exits, such as when a web page is closed or a web browser is shut down).

Each function call has its own execution context. Whenever code execution flows into a function, the function's context is pushed onto a context stack. After the function has finished executing, the stack is popped, returning control to the previously executing context. This facility controls execution flow throughout an ECMAScript program.

When code is executed in a context, a *scope chain* of variable objects is created. The purpose of the scope chain is to provide ordered access to all variables and functions that an execution context has access to. The front of the scope chain is always the variable object of the context whose code is executing. If the context is a function, then the *activation object* is used as the variable object. An activation object starts with a single defined variable called `arguments`. (This doesn't exist for the global context.) The next variable object in the chain is from the containing context, and the next after that is from the next containing context. This pattern continues until the global context is reached; the global context's variable object is always the last of the scope chain.

Identifiers are resolved by navigating the scope chain in search of the identifier name. The search always begins at the front of the chain and proceeds to the back until the identifier is found. (If the identifier isn't found, typically an error occurs.)

Consider the following code:

```
var color = "blue";

function changeColor() {
  if (color === "blue") {
    color = "red";
  } else {
    color = "blue";
  }
}

changeColor();
```

In this simple example, the function `changeColor()` has a scope chain with two objects in it: its own variable object (upon which the `arguments` object is defined) and the global context's variable object. The variable `color` is therefore accessible inside the function, because it can be found in the scope chain.

Additionally, locally defined variables can be used interchangeably with global variables in a local context. Here's an example:

```
var color = "blue";

function changeColor() {
  let anotherColor = "red";

  function swapColors() {
    let tempColor = anotherColor;
    anotherColor = color;
    color = tempColor;
  }
}
```

```

    // color, anotherColor, and tempColor are all accessible here
}

// color and anotherColor are accessible here, but not tempColor
swapColors();
}

// only color is accessible here
changeColor();

```

There are three execution contexts in this code: global context, the local context of `changeColor()`, and the local context of `swapColors()`. The global context has one variable, `color`, and one function, `changeColor()`. The local context of `changeColor()` has one variable named `anotherColor` and one function named `swapColors()`, but it can also access the variable `color` from the global context. The local context of `swapColors()` has one variable, named `tempColor`, that is accessible only within that context. Neither the global context nor the local context of `swapColors()` has access to `tempColor`. Within `swapColors()`, though, the variables of the other two contexts are fully accessible because they are parent execution contexts. Figure 4-3 represents the scope chain for the previous example.

In this figure, the rectangles represent specific execution contexts. An inner context can access everything from all outer contexts through the scope chain, but the outer contexts cannot access anything within an inner context. The connection between the contexts is linear and ordered. Each context can search up the scope chain for variables and functions, but no context can search down the scope chain into another execution context. There are three objects in the scope chain for the local context of `swapColors()`: the `swapColors()` variable object, the variable object from `changeColor()`, and the global variable object. The local context of `swapColors()` begins its search for variable and function names in its own variable object before moving along the chain. The scope chain for the `changeColor()` context has only two objects: its own variable object and the global variable object. This means that it cannot access the context of `swapColors()`.

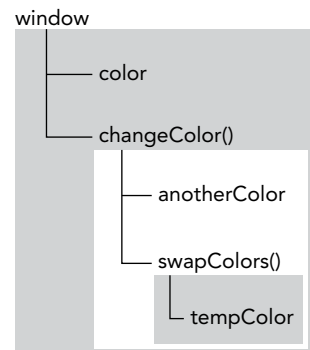

FIGURE 4-3

NOTE *Function arguments are considered to be variables and follow the same access rules as any other variable in the execution context.*

Scope Chain Augmentation

Even though there are only two primary types of execution contexts, global and function (the third exists inside of a call to `eval()`), there are other ways to augment the scope chain. Certain statements cause a temporary addition to the front of the scope chain that is later removed after code execution. There are two times when this occurs, specifically when execution enters either of the following:

- The `catch` block in a `try-catch` statement
- A `with` statement

Both of these statements add a variable object to the front of the scope chain. For the `with` statement, the specified object is added to the scope chain; for the `catch` statement, a new variable object is created and contains a declaration for the thrown error object. Consider the following:

```
function buildUrl() {
  let qs = "?debug=true";

  with(location){
    let url = href + qs;
  }

  return url;
}
```

In this example, the `with` statement is acting on the `location` object, so `location` itself is added to the front of the scope chain. There is one variable, `qs`, defined in the `buildUrl()` function. When the variable `href` is referenced, it's actually referring to `location.href`, which is in its own variable object. When the variable `qs` is referenced, it's referring to the variable defined in `buildUrl()`, which is in the function context's variable object. Inside the `with` statement is a variable declaration for `url`, which becomes part of the function's context and can, therefore, be returned as the function value.

NOTE *There is a deviation in the Internet Explorer implementation of JavaScript through Internet Explorer 8, where the error caught in a `catch` statement is added to the execution context's variable object rather than the `catch` statement's variable object, making it accessible even outside the `catch` block. This was fixed in Internet Explorer 9.*

Variable Declaration

With the introduction of ES6, JavaScript underwent a jostling transformation with regard to how variables are declared in the language. Through ECMAScript 5.1, the one-size-fits-all keyword was `var`. With ES6, not only does it introduce the two new keywords `let` and `const`, but these new keywords will overwhelmingly be the preferred declarations over `var`.

Function Scope Declaration Using `var`

When a variable is declared using `var`, it is automatically added to the most immediate context available. In a function, the most immediate one is the function's local context; in a `with` statement, the most immediate is the function context. If a variable is initialized without first being declared, it gets added to the global context automatically, as in this example:

```
function add(num1, num2) {
  var sum = num1 + num2;
  return sum;
}

let result = add(10, 20); // 30
console.log(sum);       // causes an error: sum is not a valid variable
```

Here, the function `add()` defines a local variable named `sum` that contains the result of an addition operation. This value is returned as the function value, but the variable `sum` isn't accessible outside the function. If the `var` keyword is omitted from this example, `sum` becomes accessible after `add()` has been called, as shown here:

```
function add(num1, num2) {
  sum = num1 + num2;
  return sum;
}

let result = add(10, 20); // 30
console.log(sum);       // 30
```

Here, the variable `sum` is initialized to a value without ever having been declared using `var`. When `add()` is called, `sum` is created in the global context and continues to exist even after the function has completed, allowing you to access it later.

NOTE *Initializing variables without declaring them is a very common mistake in JavaScript programming and can lead to errors. It's advisable to always declare variables before initializing them to avoid such issues. In strict mode, initializing variables without declaration causes an error.*

A `var` declaration will be brought to the top of the function or global scope and before any existing code inside it. This is referred to as “hoisting”. This allows you to safely use a hoisted variable anywhere in the same scope without consideration for whether or not it was declared yet. However, in practice, this can lead to legal yet bizarre code in which a variable is used before it is declared. Here is an example of two equivalent code snippets in the global scope:

```
var name = "Jake";

// This is equivalent to:

name = 'Jake';
var name;
```

Here is an example of two equivalent functions:

```
function fn1() {
  var name = 'Jake';
}

// This is equivalent to:
function fn2() {
  var name;
  name = 'Jake';
}
```

You can prove to yourself that a variable is hoisted by inspecting it before its declaration. The hoisting of the declaration means you will see `undefined` instead of `ReferenceError`:

```
console.log(name); // undefined
var name = 'Jake';
```

```
function() {
  console.log(name); // undefined
  var name = 'Jake';
}
```

Block Scope Declaration Using let

Brand new to ES6, `let` operates much in the same way as `var`, but it is scoped at the block level—a new concept in JavaScript. Block scope is defined as the nearest set of enclosing curly braces `{}`. This means `if` blocks, `while` blocks, `function` blocks, and even standalone blocks will be the extent of the scope of any variable declared with `let`.

```
if (true) {
  let a;
}
console.log(a); // ReferenceError: a is not defined

while (true) {
  let b;
}
console.log(b); // ReferenceError: b is not defined

function foo() {
  let c;
}
console.log(c); // ReferenceError: c is not defined
                // This should be unsurprising, as
                // a var declaration would also throw an Error

// This is not an object literal, this is a standalone block.
// The JavaScript interpreter will identify it as such based on its contents.
{
  let d;
}
console.log(d); // ReferenceError: d is not defined
```

In a similar departure from the behavior of `var`, `let` cannot be declared twice inside the same block scope. Duplicate `var` declarations are simply ignored; duplicate `let` declarations throw a `SyntaxError`.

```
var a;
var a;
// No errors thrown

{
  let b;
  let b;
}
// SyntaxError: Identifier 'b' has already been declared
```

The behavior of `let` is especially useful when using iterators inside loops. Iterator declarations using `var` will bleed outside the loop after it completes, which is frequently a very undesirable behavior.

Consider these two examples:

```
for (var i = 0; i < 10; ++i) {}
console.log(i); // 10
```

```
for (let j = 0; j < 10; ++j) {}
console.log(j); // ReferenceError: j is not defined
```

`let` is technically hoisted in the JavaScript runtime, but because of the “temporal dead zone,” you are prevented from using the variable above its actual declaration. Therefore, for the purposes of writing JavaScript, `let` is not hoisted in the same way as `var`.

Constant Declaration Using `const`

ES6 also introduces `const` as companion to `let`. A variable declared using `const` must be initialized to some value. Once declared, it cannot be reassigned to a new value at any point in its lifetime.

```
const a; // SyntaxError: Missing initializer in const declaration

const b = 3;
console.log(b); // 3
b = 4; // TypeError: Assignment to a constant variable
```

Apart from its `const` rule enforcement, `const` variables behave identically to `let` variables:

```
if (true) {
  const a = 0;
}
console.log(a); // ReferenceError: a is not defined

while (true) {
  const b = 1;
}
console.log(b); // ReferenceError: b is not defined

function foo() {
  const c = 2;
}
console.log(c); // ReferenceError: c is not defined

{
  const d = 3;
}
console.log(d); // ReferenceError: d is not defined
```

The `const` declaration only applies to the top-level primitive or object. In other words, a `const` variable assigned to an object cannot be reassigned to another reference value, but the keys inside that object are not protected.

```
const o1 = {};
o1 = {}; // TypeError: Assignment to a constant variable;

const o2 = {};
o2.name = 'Jake';
console.log(o2.name); // 'Jake'
```

If you wish to make the entire object immutable, you can use `Object.freeze()`, although attempted property assignment will not raise errors; it will just silently fail:

```
const o3 = Object.freeze({});
o3.name = 'Jake';
console.log(o3.name); // undefined
```

Because `const` declarations imply that the value is of a single type and immutable, the JavaScript runtime compiler can replace all instances of it with its actual value instead of performing a variable lookup through a lookup table. The Google Chrome V8 engine performs such an optimization.

NOTE *If your development process isn't too materially affected by it, best practices dictate that you use `const` as often as possible unless you really need a variable that can undergo reassignment. This will allow you to catch an entire vein of reassignment bugs much earlier than you normally would.*

Identifier Lookup

When an identifier is referenced for either reading or writing within a particular context, a search must take place to determine what identifier it represents. The search starts at the front of the scope chain, looking for an identifier with the given name. If it finds that identifier name in the local context, then the search stops and the variable is set; if the search doesn't find the variable name, it continues along the scope chain. (Note that objects in the scope chain also have a prototype chain, so searching may include each object's prototype chain.) This process continues until the search reaches the global context's variable object. If the identifier isn't found there, it hasn't been declared.

To better illustrate how identifier lookup occurs, consider the following example:

```
var color = 'blue';

function getColor() {
  return color;
}

console.log(getColor()); // 'blue'
```

When the function `getColor()` is called in this example, the variable `color` is referenced. At that point, a two-step search begins. First `getColor()`'s variable object is searched for an identifier named `color`. When it isn't found, the search goes to the next variable object (from the global context) and then searches for an identifier named `color`. Because `color` is defined in that variable object, the search ends.

Given this search process, referencing local variables automatically stops the search from going into another variable object. This means that identifiers in a parent context cannot be referenced if an identifier in the local context has the same name, as in this example:

```
var color = 'blue';

function getColor() {
  let color = 'red';
  return color;
}

console.log(getColor()); // 'red'
```

Using block scoped declarations does not change the search process, but it can add extra levels to the lexical hierarchy:

```
var color = 'blue';

function getColor() {
```



```
    let color = 'red';
    {
      let color = 'green';
      return color;
    }
  }

console.log(getColor()); // 'green'
```

In this modified code, a local variable named `color` is declared inside the `getColor()` function. When the function is called, the variable is declared. When the second line of the function is executed, it knows that a variable named `color` must be used. The search begins in the local context, where it finds a variable named `color` with a value of `'green'`. Because the variable was found, the search stops and the local variable is used, meaning that the function returns `'green'`. Any lines of code appearing after the declaration of `color` as a local variable cannot access the global `color` variable without qualifying it as `window.color`. If one of the operands is an object and the other is not, the `valueOf()` method is called on the object to retrieve a primitive value to compare according to the previous rules.

NOTE *Variable lookup doesn't come without a price. It's faster to access local variables than global variables because there's no search up the scope chain. JavaScript engines are getting better at optimizing identifier lookup, however, so this difference may end up negligible in the future.*

GARBAGE COLLECTION

JavaScript is a garbage-collected language, meaning that the execution environment is responsible for managing the memory required during code execution. In languages such as C and C++, keeping track of memory usage is a principle concern and the source of many issues for developers. JavaScript frees developers from worrying about memory management by automatically allocating what is needed and reclaiming memory that is no longer being used. The basic idea is simple: figure out which variables aren't going to be used and free the memory associated with them. This process is periodic, with the garbage collector running at specified intervals (or at predefined collection moments in code execution). The process of garbage collection is an approximate and imperfect solution because the general problem of knowing whether some piece of memory is needed is “undecidable,” meaning it cannot be solved by an algorithm.

Consider the normal life cycle of a local variable in a function. The variable comes into existence during the execution of the function. At that time, memory is allocated on the stack (and possibly on the heap) to provide storage space for the value. The variable is used inside the function and then the function ends. At that point, this variable is no longer needed, so its memory can be reclaimed for later use. In this situation, it's obvious that the variable isn't needed, but not all situations are as obvious. The garbage collector must keep track of which variables can and can't be used so it can identify likely candidates for memory reclamation. The strategy for identifying the unused variables may differ on an implementation basis, though two strategies have traditionally been used in browsers: mark-and-sweep, and reference counting.

Mark-and-Sweep

The most popular form of garbage collection for JavaScript is called *mark-and-sweep*. When a variable comes into context, such as when a variable is declared inside a function, it is flagged as being in context. Variables that are in context, logically, should never have their memory freed, because they may be used as long as execution continues in that context. When a variable goes out of context, it is also flagged as being out of context.

Variables can be flagged in any number of ways. There may be a specific bit that is flipped when a variable is in context, or there may be an “in-context” variable list and an “out-of-context” variable list between which variables are moved. The implementation of the flagging is unimportant; it’s really the theory that is key.

When the garbage collector runs, it marks all variables stored in memory (once again, in any number of ways). It then clears its mark off of variables that are in context and variables that are referenced by in-context variables. The variables that are marked after that are considered ready for deletion, because they can’t be reached by any in-context variables. The garbage collector then does a *memory sweep*, destroying each of the marked values and reclaiming the memory associated with them.

As of 2008, Internet Explorer, Firefox, Opera, Chrome, and Safari all use mark-and-sweep garbage collection (or variations thereof) in their JavaScript implementations, though the timing of garbage collection differs.

Reference Counting

A second, less-popular type of garbage collection is *reference counting*. The idea is that every value keeps track of how many references are made to it. When a variable is declared and a reference value is assigned, the reference count is one. If another variable is then assigned to the same value, the reference count is incremented. Likewise, if a variable with a reference to that value is overwritten with another value, then the reference count is decremented. When the reference count of a value reaches zero, there is no way to reach that value and it is safe to reclaim the associated memory. The garbage collector frees the memory for values with a reference count of zero the next time it runs.

Reference counting was initially used by Netscape Navigator 3.0 and immediately met with a serious issue: circular references. A *circular reference* occurs when object A has a pointer to object B and object B has a reference to object A, as in the following example:

```
function problem() {
  let objectA = new Object();
  let objectB = new Object();

  objectA.someOtherObject = objectB;
  objectB.anotherObject = objectA;
}
```

In this example, `objectA` and `objectB` reference each other through their properties, meaning that each has a reference count of two. In a mark-and-sweep system, this wouldn’t be a problem because both objects go out of scope after the function has completed. In a reference-counting system, however, `objectA` and `objectB` will continue to exist after the function has exited because their reference counts will never reach zero. If this function were called repeatedly, it would lead to a large amount of memory never being reclaimed. For this reason, Netscape abandoned a reference-counting

garbage-collection routine in favor of a mark-and-sweep implementation in version 4.0. Unfortunately, that's not where the reference-counting problem ended.

Not all objects in Internet Explorer 8 and earlier are native JavaScript objects. Objects in the Browser Object Model (BOM) and Document Object Model (DOM) are implemented as COM (Component Object Model) objects in C++, and COM objects use reference counting for garbage collection. So even though the Internet Explorer JavaScript engine uses a mark-and-sweep implementation, any COM objects that are accessed in JavaScript still use reference counting, meaning circular references are still a problem when COM objects are involved. The following simple example demonstrates a circular reference with a COM object:

```
let element = document.getElementById("some_element");
let myObject = new Object();
myObject.element = element;
element.someObject = myObject;
```

This example sets up a circular reference between a DOM element (`element`) and a native JavaScript object (`myObject`). The `myObject` variable has a property called `element` that points to `element`, and the `element` variable has a property called `someObject` that points back to `myObject`. Because of this circular reference, the memory for the DOM element will never be reclaimed even if it is removed from the page.

To avoid circular reference problems such as this, you should break the connection between native JavaScript objects and DOM elements when you're finished using them. For example, the following code cleans up the circular references in the previous example:

```
myObject.element = null;
element.someObject = null;
```

Setting a variable to `null` effectively severs the connection between the variable and the value it previously referenced. The next time the garbage collector runs, these values will be deleted and the memory will be reclaimed.

Internet Explorer 9 remedied some of these problems by making BOM and DOM objects into true JavaScript objects, thus avoiding the problem of having two different garbage-collection algorithms and eliminating common memory leak issues.

NOTE *There are several other patterns that may cause circular references, and they will be covered throughout this book.*

Performance

The garbage collector runs periodically and can potentially be an expensive process if there are a large number of variable allocations in memory, so the timing of the garbage-collection process is important. In particular, on mobile devices with limited system memory, garbage collection can noticeably degrade the speed and framerate of rendering. You cannot know when garbage collection is coming, so the best strategy is to organize your code in such a way that it allows garbage collection to do its job to the best of its ability whenever it is scheduled to run.

Modern garbage collectors decide when to run based on a collection of heuristics that are measured from the JavaScript runtime environment. These heuristics will vary by engine, but they will all be approximately based upon the size and number of objects that have been allocated. For example, from a V8 blog post in 2016: “At the end of a full garbage collection, V8’s heap growing strategy determines when the next garbage collection will happen based on the amount of live objects with some additional slack.”

Internet Explorer was infamous for its performance issues related to how often the garbage collector ran—it ran based on the number of allocations, specifically 256 variable allocations, 4,096 object/array literals and array slots, or 64KB of strings. If any of these thresholds were reached, the garbage collector would run. The problem with this implementation is that a script with so many variables will probably continue to have that many variables throughout its lifetime, meaning the garbage collector will run quite frequently. This issue caused serious performance problems that led to changes in the garbage-collection routine in Internet Explorer 7.

With the release of Internet Explorer 7, the JavaScript engine’s garbage-collection routine was tuned to dynamically change the allocation threshold of variables, literals, and/or array slots that triggered garbage collection. The Internet Explorer 7 thresholds start out equal to those in Internet Explorer 6. If the garbage-collection routine reclaims less than 15 percent of the allocations, the threshold for variables, literals, and/or array slots doubles. If the routine ever reclaims 85 percent of the allocations, then the threshold is reset to the default. This simple change greatly improved the performance of the browser on JavaScript-heavy web pages.

WARNING *It’s possible, though not recommended, to trigger the garbage-collection process in some browsers. In Internet Explorer, the `window.CollectGarbage()` method causes garbage collection to occur immediately. In Opera 7 and higher, calling `window.opera.collect()` initiates the garbage-collection process.*

Managing Memory

In a garbage-collected programming environment, developers typically don’t have to worry about memory management. However, JavaScript runs in an environment where memory management and garbage collection operate uniquely. The amount of memory available for use in web browsers is typically much less than is available for desktop applications, and even more so for mobile browsers. This is more of a security feature than anything else, ensuring that a web page running JavaScript can’t crash the operating system by using up all the system memory. The memory limits affect not only variable allocation but also the call stack and the number of statements that can be executed in a single thread.

Keeping the amount of used memory to a minimum leads to better page performance. The best way to optimize memory usage is to ensure that you’re keeping around only data that is necessary for the execution of your code. When data is no longer necessary, it’s best to set the value to `null`, freeing up the reference—this is called *dereferencing* the value. This advice applies mostly to global values

and properties of global objects. Local variables are dereferenced automatically when they go out of context, as in this example:

```
function createPerson(name) {
  let localPerson = new Object();
  localPerson.name = name;
  return localPerson;
}

let globalPerson = createPerson("Nicholas");

// do something with globalPerson

globalPerson = null;
```

In this code, the variable `globalPerson` is filled with a value returned from the `createPerson()` function. Inside `createPerson()`, `localPerson` creates an object and adds a `name` property to it. The variable `localPerson` is returned as the function value and assigned to `globalPerson`. Because `localPerson` goes out of context after `createPerson()` has finished executing, it doesn't need to be dereferenced explicitly. Because `globalPerson` is a global variable, it should be dereferenced when it's no longer needed, which is what happens in the last line.

Keep in mind that dereferencing a value doesn't automatically reclaim the memory associated with it. The point of dereferencing is to make sure the value is out of context and will be reclaimed the next time garbage collection occurs.

Performance Boosts with `const` and `let` Declarations

The introduction of these keywords in ES6 isn't just a boon for your code style but also for the garbage collection process. Because `const` and `let` are scoped to a block instead of a function, depending on how your code is organized this may signal to the garbage collector that an allocated variable is eligible for cleanup far sooner than it would have been when using `var`. This would occur in situations when the block scope terminates far sooner than the function scope.

Hidden Classes and the `delete` Operation

Depending on where you expect your JavaScript to run, it is sometimes worth considering various performance implications based on which JavaScript engine a browser uses. As of 2017, the most popular web browser is Google Chrome, which uses the V8 JavaScript engine. This engine utilizes "hidden classes" when compiling the interpreted JavaScript code into actual machine code, and if you are writing performance-sensitive code, this might matter to you.

During runtime, V8 will associate hidden classes for every object created to keep track of the shape of its properties. Objects that are able to share the same hidden class will have better performance, and V8 will optimize for this but may not always be able to. Consider the following code snippet:

```
function Article() {
  this.title = 'Inauguration Ceremony Features Kazoo Band';
}

let a1 = new Article();
let a2 = new Article();
```

Behind the scenes, V8 will configure the two class instances to share the same hidden class. This makes sense because they share a constructor and prototype. Suppose you then appended the following line to the end of this code:

```
a2.author = 'Jake';
```

Now, the two `Article` instances will have two divergent hidden class implementations. Depending on the frequency of this operation and the size of the hidden classes, this can have meaningful impacts on performance.

The solution, of course, is to avoid JavaScript's ready-fire-aim dynamic property assignment and instead declare all properties inside the constructor, as shown here:

```
function Article(opt_author) {
  this.title = 'Inauguration Ceremony Features Kazoo Band';
  this.author = opt_author;
}

let a1 = new Article();
let a2 = new Article('Jake');
```

Now, the two instances will behave in essentially the same way (not counting the return values of `hasOwnProperty`), and they will also share a hidden class, potentially yielding improved performance. Bear in mind though that using the `delete` keyword can generate the same hidden class fragmentation. This is demonstrated here:

```
function Article() {
  this.title = 'Inauguration Ceremony Features Kazoo Band';
  this.author = 'Jake';
}

let a1 = new Article();
let a2 = new Article();

delete a1.author;
```

At the end of this snippet, the two instances will no longer share a hidden class even though they use a unified constructor. Dynamic deletion of a property will yield the same effect as dynamic addition. Best practices dictate that unwanted properties should be set to `null`. It will allow the hidden classes to remain intact and shared, and it has the same effect on removing references for the benefit of the garbage collector.

```
function Article() {
  this.title = 'Inauguration Ceremony Features Kazoo Band';
  this.author = 'Jake';
}

let a1 = new Article();
let a2 = new Article();

a1.author = null;
```

Memory Leaks

Poorly written JavaScript can yield some sneaky and insidious memory leaks. On devices with limited memory, or in the context of functions that are called many times, this can cause big problems. Overwhelmingly, memory leaks in JavaScript are caused by unwanted references.

One of the most common and easily fixed memory leaks is accidentally declaring global variables. In the following code, the variable is not prefixed with a declaration keyword:

```
function setName() {  
  name = 'Jake';  
}
```

In this example, the interpreter will handle this as `window.name = 'Jake'`, and, of course, properties set on the `window` object will never be cleaned up if the `window` object itself is not cleaned up. This is easily fixed by prefixing the declaration with `var`, `let`, or `const`, which will all go out of scope at the end of the function's execution.

Interval timers can also quietly cause memory leaks. In the following code, the code sets an interval, which references a variable provided through a closure:

```
let name = 'Jake';  
setInterval(() => {  
  console.log(name);  
}, 100);
```

As long as this interval timer is running, the handler function containing a reference to `name` remains allocated. The garbage collector recognizes this and therefore is unable to clean up the outer variable.

JavaScript closures are an exceedingly common way to leak memory without realizing it. Consider the following example:

```
let outer = function() {  
  let name = 'Jake';  
  return function() {  
    return name;  
  };  
};
```

This leaks the memory allocated for `name`. This code creates an internal closure, so as long as the `outer` function exists, the `name` variable cannot be cleaned up because there will be a persistent reference to it through that closure. If the contents of the `name` variable were extremely large instead of just a short string, major problems could result.

Static Allocation and Object Pools

At the very end of the JavaScript performance spectrum, you may find yourself wanting to squeeze the very last bit of performance juice out of the browser. To accomplish this, a good place to focus is on minimizing the number of garbage collection operations the browser performs. Because you do not directly control when garbage collection occurs, you can instead optimize around the heuristics that browsers use when scheduling garbage collection. In theory, if you can responsibly use allocated memory and at the same time obviate superfluous garbage collection, then you will be able to make performance gains that would otherwise be lost freeing memory.

One important metric measured by the browser to decide when to schedule garbage collection is the rate of object churn. If lots of objects are being instantiated and then going out of scope, the browser will schedule garbage collections more aggressively, which of course will slow down the application. Consider the following example, a two dimensional vector addition function:

```
function addVector(a, b) {  
  let resultant = new Vector();
```

```

    resultant.x = a.x + b.x;
    resultant.y = a.y + b.y;
    return resultant;
}

```

When invoked, this function creates a new object on the heap, modifies it, and returns it to the caller. If the lifetime of this vector object is short, it will soon lose all its references and be eligible for garbage collection. If this vector addition function is called frequently, the garbage collection scheduler will see this high rate of object churn, and garbage collection will be scheduled more frequently.

Instead of this dynamic vector creation, suppose you changed the method to use an existing vector object:

```

function addVector(a, b, resultant) {
    resultant.x = a.x + b.x;
    resultant.y = a.y + b.y;
    return resultant;
}

```

Of course, this requires the `resultant` vector argument to be fresh and instantiated somewhere else, but the behavior of this function is the same. Where then to create a vector while avoiding the gaze of the garbage collector heuristics?

One strategy is to use an object pool. At some point in initialization, you will create an object pool that manages a collection of recyclable objects. Your application can request an object from this pool, set its properties, use it, and return it to the pool when it's done. Because no object instantiation is occurring, garbage collection heuristics won't measure an uptick in object churn, and garbage collection will occur less frequently. An object pool pseudo-implementation might look something like this:

```

// vectorPool is the existing object pool
let v1 = vectorPool.allocate();
let v2 = vectorPool.allocate();
let v3 = vectorPool.allocate();

v1.x = 10;
v1.y = 5;
v2.x = -3;
v2.y = -6;

addVector(v1, v2, v3);

console.log([v3.x, v3.y]); // [7, -1]

vectorPool.free(v1);
vectorPool.free(v2);
vectorPool.free(v3);

// If the objects had properties referencing other objects,
// those would need to be set to null here as well
v1 = null;
v2 = null;
v3 = null;

```

If the object pool only allocates vectors as necessary (which creates new ones when they don't exist and reuses ones that already exist), this implementation is essentially a greedy algorithm that will

have monotonically increasing yet static memory. This pool must maintain the collection using some structure, and a good choice is an Array. However, the implementation using an array must be designed carefully as to not incur additional garbage collection. Consider the following example:

```
let vectorList = new Array(100);  
let vector = new Vector();  
vectorList.push(vector);
```

Because JavaScript uses dynamically sized arrays, the engine will delete the array of size 100 and create a new array of size 200. The garbage collector will see this deletion and may be encouraged to run sooner because of it. This dynamic allocation can be avoided by creating an appropriately sized array upon initialization, which will enable you to avoid the aforementioned resizing operation. It will require, however, that you gain a sense of how large this array should be.

NOTE *Static allocation is an extreme form of optimization. It will yield performance gains when your application's performance is hindered by garbage collection overhead, but this will be the case very infrequently. In most cases, this is a form of premature optimization and is not appropriate.*

SUMMARY

Two types of values can be stored in JavaScript variables: primitive values and reference values. Primitive values have one of the six primitive data types: Undefined, Null, Boolean, Number, String, and Symbol. Primitive and reference values have the following characteristics:

- Primitive values are of a fixed size and so are stored in memory on the stack.
- Copying primitive values from one variable to another creates a second copy of the value.
- Reference values are objects and are stored in memory on the heap.
- A variable containing a reference value actually contains just a pointer to the object, not the object itself.
- Copying a reference value to another variable copies just the pointer, so both variables end up referencing the same object.
- The `typeof` operator determines a value's primitive type, whereas the `instanceof` operator is used to determine the reference type of a value.

All variables, primitive and reference, exist within an execution context (also called a scope) that determines the lifetime of the variable and which parts of the code can access it. Execution context can be summarized as follows:

- Execution contexts exist globally (called the global context), within functions, and within blocks.
- Each time a new execution context is entered, it creates a scope chain to search for variables and functions.

- Contexts that are local to a function or block have access not only to variables in that scope but also to variables in any containing contexts and the global context.
- The global context has access only to variables and functions in the global context and cannot directly access any data inside local contexts.
- The execution context of variables helps to determine when memory will be freed.

JavaScript is a garbage-collected programming environment where the developer need not be concerned with memory allocation or reclamation. JavaScript's garbage-collection routine can be summarized as follows:

- Values that go out of scope will automatically be marked for reclamation and will be deleted during the garbage-collection process.
- The predominant garbage-collection algorithm is called mark-and-sweep, which marks values that aren't currently being used and then goes back to reclaim that memory.
- Another algorithm is reference counting, which keeps track of how many references there are to a particular value. JavaScript engines no longer use this algorithm, but it still affects Internet Explorer because of nonnative JavaScript objects (such as DOM elements) being accessed in JavaScript.
- Reference counting causes problems when circular references exist in code.
- Dereferencing variables helps not only with circular references but also with garbage collection in general. To aid in memory reclamation, global objects, properties on global objects, and circular references should all be dereferenced when no longer needed.

5

Basic Reference Types

WHAT'S IN THIS CHAPTER?

- Working with objects
- Understanding basic JavaScript data types
- Working with primitives and primitive wrappers

WROX.COM DOWNLOADS FOR THIS CHAPTER

Please note that all the code examples for this chapter are available as a part of this chapter's code download on the book's website at www.wrox.com/go/projavascript4e on the Download Code tab.

A reference value (object) is an instance of a specific *reference type*. In ECMAScript, reference types are structures used to group data and functionality together and are often incorrectly called *classes*. Although technically an object-oriented language, ECMAScript lacks some basic constructs that have traditionally been associated with object-oriented programming, including classes and interfaces. Reference types are also sometimes called *object definitions* because they describe the properties and methods that objects should have.

NOTE *Even though reference types are similar to classes, the two concepts are not equivalent. To avoid any confusion, the term “class” is not used in the rest of this chapter.*

Again, objects are considered to be *instances* of a particular reference type. New objects are created by using the `new` operator followed by a *constructor*. A constructor is simply a function whose purpose is to create a new object. Consider the following line of code:

```
let now = new Date();
```

This code creates a new instance of the `Date` reference type and stores it in the variable `now`. The constructor being used is `Date()`, which creates a simple object with only the default properties and methods. ECMAScript provides a number of native reference types, such as `Date`, to help developers with common computing tasks.

NOTE *Functions are a reference type, but they are too broad of a topic for this chapter and therefore have an entire chapter devoted to them. Refer to the Functions chapter.*

THE DATE TYPE

The ECMAScript `Date` type is based on an early version of `java.util.Date` from Java. As such, the `Date` type stores dates as the number of milliseconds that have passed since midnight on January 1, 1970 UTC (Universal Time Code). Using this data storage format, the `Date` type can accurately represent dates 285,616 years before or after January 1, 1970.

To create a date object, use the `new` operator along with the `Date` constructor, like this:

```
let now = new Date();
```

When the `Date` constructor is used without any arguments, the created object is assigned the current date and time. To create a date based on another date or time, you must pass in the millisecond representation of the date (the number of milliseconds after midnight, January 1, 1970 UTC, the Unix epoch). To aid in this process, ECMAScript provides two methods: `Date.parse()` and `Date.UTC()`.

The `Date.parse()` method accepts a string argument representing a date. It attempts to convert the string into a millisecond representation of a date. ECMA-262 fifth edition defines which date formats `Date.parse()` should support, filling in a void left by the third edition. All implementations must now support the following date formats:

- `month/date/year` (such as `5/23/2019`)
- `month_name date, year` (such as `May 23, 2019`)
- `day_of_week month_name date year hours:minutes:seconds time_zone` (such as `Tue May 23 2019 00:00:00 GMT-0700`)
- ISO 8601 extended format `YYYY-MM-DDTHH:mm:ss.sssZ` (such as `2019-05-23T00:00:00`). This works only in ECMAScript 5-compliant implementations.

For instance, to create a date object for May 23, 2019, you can use the following code:

```
let someDate = new Date(Date.parse("May 23, 2019"));
```

If the string passed into `Date.parse()` doesn't represent a date, then it returns `NaN`. The `Date` constructor will call `Date.parse()` behind the scenes if a string is passed in directly, meaning that the following code is identical to the previous example:

```
let someDate = new Date("May 23, 2019");
```

This code produces the same result as the previous example.

NOTE *There are a lot of quirks surrounding the `Date` type and its implementation in various browsers. There is a tendency to replace out-of-range values with the current value to produce an output, so when trying to parse "January 32, 2019", some browsers will interpret it as "February 1, 2019", whereas Opera tends to insert the current day of the current month, returning "January current_day, 2019". This means running the code on September 21 returns "January 21, 2019".*

The `Date.UTC()` method also returns the millisecond representation of a date but constructs that value using different information than `Date.parse()`. The arguments for `Date.UTC()` are the year, the zero-based month (January is 0, February is 1, and so on), the day of the month (1 through 31), and the hours (0 through 23), minutes, seconds, and milliseconds of the time. Of these arguments, only the first two (year and month) are required. If the day of the month isn't supplied, it's assumed to be 1, while all other omitted arguments are assumed to be 0. Here are two examples of `Date.UTC()` in action:

```
// January 1, 2000 at midnight GMT
let y2k = new Date(Date.UTC(2000, 0));

// May 5, 2005 at 5:55:55 PM GMT
let allFives = new Date(Date.UTC(2005, 4, 5, 17, 55, 55));
```

Two dates are created in this example. The first date is for midnight (GMT) on January 1, 2000, which is represented by the year 2000 and the month 0 (which is January). Because the other arguments are filled in (the day of the month as 1 and everything else as 0), the result is the first day of the month at midnight. The second date represents May 5, 2005, at 5:55:55 PM GMT. Even though the date and time contain only fives, creating this date requires some different numbers: the month must be set to 4 because months are zero-based, and the hour must be set to 17 because hours are represented as 0 through 23. The rest of the arguments are as expected.

As with `Date.parse()`, `Date.UTC()` is mimicked by the `Date` constructor but with one major difference: the date and time created are in the local time zone, not in GMT. However, the `Date` constructor takes the same arguments as `Date.UTC()`, so if the first argument is a number, the constructor assumes that it is the year of a date, the second argument is the month, and so on. The preceding example can then be rewritten as this:

```
// January 1, 2000 at midnight in local time
let y2k = new Date(2000, 0);

// May 5, 2005 at 5:55:55 PM local time
let allFives = new Date(2005, 4, 5, 17, 55, 55);
```

This code creates the same two dates as the previous example, but this time both dates are in the local time zone as determined by the system settings.

ECMAScript also offers `Date.now()`, which returns the millisecond representation of the date and time at which the method is executed. This method makes it trivial to use `Date` objects for code profiling, such as:

```
// get start time
let start = Date.now();

// call a function
doSomething();

// get stop time
let stop = Date.now(),
    result = stop - start;
```

Inherited Methods

As with the other reference types, the `Date` type overrides `toLocaleString()`, `toString()`, and `valueOf()`, though unlike the previous types, each method returns something different. The `Date` type's `toLocaleString()` method returns the date and time in a format appropriate for the locale in which the browser is being run. This often means that the format includes AM or PM for the time and doesn't include any time-zone information (the exact format varies from browser to browser). The `toString()` method typically returns the date and time with time-zone information, and the time is typically indicated in 24-hour notation (hours ranging from 0 to 23). The following displays the format for `toLocaleString()` and `toString()` when representing the date/time of February 1, 2019, at midnight PST (Pacific Standard Time) in the "en-US" locale:

```
toLocaleString() - 2/1/2019 12:00:00 AM
toString() - Thu Feb 1 2019 00:00:00 GMT-0800 (Pacific Standard Time)
```

Modern browsers have converged to output the same strings for these two methods. When using legacy browsers, there are differences between the formats that browsers return for each method. These differences mean `toLocaleString()` and `toString()` are useful only for debugging purposes, not for display purposes.

The `valueOf()` method for the `Date` type doesn't return a string at all because it is overridden to return the milliseconds representation of the date so that operators (such as less-than and greater-than) will work appropriately for date values. Consider this example:

```
let date1 = new Date(2019, 0, 1); // "January 1, 2019"
let date2 = new Date(2019, 1, 1); // "February 1, 2019"

console.log(date1 < date2); // true
console.log(date1 > date2); // false
```

The date January 1, 2019, comes before February 1, 2019, so it would make sense to say that the former is less than the latter. Because the milliseconds representation of January 1, 2019, is less than that of February 1, 2019, the less-than operator returns `true` when the dates are compared, providing an easy way to determine the order of dates.

Date-Formatting Methods

There are several `Date` type methods used specifically to format the date as a string. They are as follows:

- `toDateString()`—Displays the date’s day of the week, month, day of the month, and year in an implementation-specific format.
- `toTimeString()`—Displays the date’s hours, minutes, seconds, and time zone in an implementation-specific format.
- `toLocaleDateString()`—Displays the date’s day of the week, month, day of the month, and year in an implementation- and locale-specific format.
- `toLocaleTimeString()`—Displays the date’s hours, minutes, and seconds in an implementation-specific format.
- `toUTCString()`—Displays the complete UTC date in an implementation-specific format.

The output of these methods, as with `toLocaleString()` and `toString()`, varies widely from browser to browser and therefore can’t be employed in a user interface for consistent display of a date.

NOTE *There is also a method called `toGMTString()`, which is equivalent to `toUTCString()` and is provided for backwards compatibility. However, the specification recommends that new code use `toUTCString()` exclusively.*

Date/Time Component Methods

The remaining methods of the `Date` type (listed in the following table) deal directly with getting and setting specific parts of the date value. Note that references to a UTC date mean the date value when interpreted without a time-zone offset (the date when converted to GMT).

METHOD	DESCRIPTION
<code>getTime()</code>	Returns the milliseconds representation of the date; same as <code>valueOf()</code> .
<code>setTime(<i>milliseconds</i>)</code>	Sets the milliseconds representation of the date, thus changing the entire date.
<code>getFullYear()</code>	Returns the four-digit year (2019 instead of just 19).
<code>getUTCFullYear()</code>	Returns the four-digit year of the UTC date value.
<code>setFullYear(<i>year</i>)</code>	Sets the year of the date. The year must be given with four digits (2019 instead of just 19).
<code>setUTCFullYear(<i>year</i>)</code>	Sets the year of the UTC date. The year must be given with four digits (2019 instead of just 19).

METHOD	DESCRIPTION
<code>getMonth()</code>	Returns the month of the date, where 0 represents January and 11 represents December.
<code>getUTCMonth()</code>	Returns the month of the UTC date, where 0 represents January and 11 represents December.
<code>setMonth(<i>month</i>)</code>	Sets the month of the date, which is any number 0 or greater. Numbers greater than 11 add years.
<code>setUTCMonth(<i>month</i>)</code>	Sets the month of the UTC date, which is any number 0 or greater. Numbers greater than 11 add years.
<code>getDate()</code>	Returns the day of the month (1 through 31) for the date.
<code>getUTCDate()</code>	Returns the day of the month (1 through 31) for the UTC date.
<code>setDate(<i>date</i>)</code>	Sets the day of the month for the date. If the date is greater than the number of days in the month, the month value also gets increased.
<code>setUTCDate(<i>date</i>)</code>	Sets the day of the month for the UTC date. If the date is greater than the number of days in the month, the month value also gets increased.
<code>getDay()</code>	Returns the date's day of the week as a number (where 0 represents Sunday and 6 represents Saturday).
<code>getUTCDay()</code>	Returns the UTC date's day of the week as a number (where 0 represents Sunday and 6 represents Saturday).
<code>getHours()</code>	Returns the date's hours as a number between 0 and 23.
<code>getUTCHours()</code>	Returns the UTC date's hours as a number between 0 and 23.
<code>setHours(<i>hours</i>)</code>	Sets the date's hours. Setting the hours to a number greater than 23 also increments the day of the month.
<code>setUTCHours(<i>hours</i>)</code>	Sets the UTC date's hours. Setting the hours to a number greater than 23 also increments the day of the month.
<code>getMinutes()</code>	Returns the date's minutes as a number between 0 and 59.
<code>getUTCMinutes()</code>	Returns the UTC date's minutes as a number between 0 and 59.
<code>setMinutes(<i>minutes</i>)</code>	Sets the date's minutes. Setting the minutes to a number greater than 59 also increments the hour.
<code>setUTCMinutes(<i>minutes</i>)</code>	Sets the UTC date's minutes. Setting the minutes to a number greater than 59 also increments the hour.
<code>getSeconds()</code>	Returns the date's seconds as a number between 0 and 59.

METHOD	DESCRIPTION
<code>getUTCSeconds()</code>	Returns the UTC date's seconds as a number between 0 and 59.
<code>setSeconds(<i>seconds</i>)</code>	Sets the date's seconds. Setting the seconds to a number greater than 59 also increments the minutes.
<code>setUTCSeconds(<i>seconds</i>)</code>	Sets the UTC date's seconds. Setting the seconds to a number greater than 59 also increments the minutes.
<code>getMilliseconds()</code>	Returns the date's milliseconds.
<code>getUTCMilliseconds()</code>	Returns the UTC date's milliseconds.
<code>setMilliseconds(<i>milliseconds</i>)</code>	Sets the date's milliseconds.
<code>setUTCMilliseconds(<i>milliseconds</i>)</code>	Sets the UTC date's milliseconds.
<code>getTimezoneOffset()</code>	Returns the number of minutes that the local time zone is offset from UTC. For example, Eastern Standard Time returns 300. This value changes when an area goes into Daylight Saving Time.

THE REGEXP TYPE

ECMAScript supports regular expressions through the RegExp type. Regular expressions are easy to create using syntax similar to Perl, as shown here:

```
let expression = /pattern/flags;
```

The pattern part of the expression can be any simple or complicated regular expression, including character classes, quantifiers, grouping, lookaheads, and backreferences. Each expression can have zero or more flags indicating how the expression should behave. Three supported flags represent matching modes, as follows:

- `g`—Indicates global mode, meaning the pattern will be applied to all of the string instead of stopping after the first match is found.
- `i`—Indicates case-insensitive mode, meaning the case of the pattern and the string are ignored when determining matches.
- `m`—Indicates multiline mode, meaning the pattern will continue looking for matches after reaching the end of one line of text.
- `y`—Indicates sticky mode, meaning the pattern will only look at the string contents beginning at `lastIndex`.
- `u`—Indicates Unicode mode is enabled.

A regular expression is created using a combination of a pattern and these flags to produce different results, as in this example:

```
// Match all instances of "at" in a string.
let pattern1 = /at/g;

// Match the first instance of "bat" or "cat", regardless of case.
let pattern2 = /[bc]at/i;

// Match all three-character combinations ending with "at", regardless of case.
let pattern3 = /.at/gi;
```

As with regular expressions in other languages, all *metacharacters* must be escaped when used as part of the pattern. The metacharacters are as follows:

```
( [ { \ ^ $ | ) ] } ? * + .
```

Each metacharacter has one or more uses in regular-expression syntax and so must be escaped by a backslash when you want to match the character in a string. Here are some examples:

```
// Match the first instance of "bat" or "cat", regardless of case.
let pattern1 = /[bc]at/i;

// Match the first instance of "[bc]at", regardless of case.
let pattern2 = /\[bc\]at/i;

// Match all three-character combinations ending with "at", regardless of case.
let pattern3 = /.at/gi;

// Match all instances of ".at", regardless of case.
let pattern4 = /\.at/gi;
```

In this code, `pattern1` matches all instances of "bat" or "cat", regardless of case. To match "[bc]at" directly, both square brackets need to be escaped with a backslash, as in `pattern2`. In `pattern3`, the dot indicates that any character can precede "at" to be a match. If you want to match ".at", then the dot needs to be escaped, as in `pattern4`.

The preceding examples all define regular expressions using the literal form. Regular expressions can also be created by using the `RegExp` constructor, which accepts two arguments: a string pattern to match and an optional string of flags to apply. Any regular expression that can be defined using literal syntax can also be defined using the constructor, as in this example:

```
// Match the first instance of "bat" or "cat", regardless of case.
let pattern1 = /[bc]at/i;

// Same as pattern1, just using the constructor.
let pattern2 = new RegExp("[bc]at", "i");
```

Here, `pattern1` and `pattern2` define equivalent regular expressions. Note that both arguments of the `RegExp` constructor are strings (regular-expression literals should not be passed into the `RegExp` constructor). Because the pattern argument of the `RegExp` constructor is a string, there are some instances in which you need to double-escape characters. All metacharacters must be double-escaped, as must characters that are already escaped, such as `\n` (the `\` character, which is normally escaped in strings as `\\` becomes `\\\\` when used in a regular-expression string). The following table shows some patterns in their literal form and the equivalent string that would be necessary to use the `RegExp` constructor.

LITERAL PATTERN	STRING EQUIVALENT
<code>/\[bc\]at/</code>	<code>"\\[bc\\]at"</code>
<code>/\\.at/</code>	<code>"\\.at"</code>
<code>/name\\/age/</code>	<code>"name\\/age"</code>
<code>/\\d\\.\\d{1,2}/</code>	<code>"\\.\\d\\.\\d{1,2}"</code>
<code>/\\w\\hello\\123/</code>	<code>"\\w\\hello\\123"</code>

Keep in mind that creating a regular expression using a literal is not exactly the same as creating a regular expression using the `RegExp` constructor. Regular-expression literals always share the same `RegExp` instance, while creating a new `RegExp` via constructor always results in a new instance. Consider the following:

```
let re = null;
for (let i = 0; i < 10; i++) {
  re = /cat/g;
  re.test("catastrophe");
}
for (let i = 0; i < 10; i++) {
  re = new RegExp("cat", "g");
  re.test("catastrophe");
}
```

In the first loop, there is only one instance of `RegExp` created for `/cat/`, even though it is specified in the body of the loop. Instance properties (mentioned in the next section) are not reset, so calling `test()` fails every other time through the loop. This happens because the `"cat"` is found in the first call to `test()`, but the second call begins its search from index 3 (the end of the last match) and can't find it. Because the end of the string is found, the subsequent call to `test()` starts at the beginning again.

The second loop uses the `RegExp` constructor to create the regular expression each time through the loop. Each call to `test()` returns `true` because a new instance of `RegExp` is created for each iteration.

ECMAScript regular-expression literals create new instances of `RegExp` as if the `RegExp` constructor were called directly.

It is also possible to copy existing regular expression instances and optionally modify their flags using the constructor:

```
const re1 = /cat/g;
console.log(re1); // "/cat/g"

const re2 = new RegExp(re1);
console.log(re2); // "/cat/g"

const re3 = new RegExp(re1, "i");
console.log(re3); // "/cat/i"
```

RegExp Instance Properties

Each instance of `RegExp` has the following properties that allow you to get information about the pattern:

- `global`—A Boolean value indicating whether the `g` flag has been set.
- `ignoreCase`—A Boolean value indicating whether the `i` flag has been set.
- `unicode`—A Boolean value indicating whether the `u` flag has been set.
- `sticky`—A Boolean value indicating whether the `y` flag has been set.
- `lastIndex`—An integer indicating the character position where the next match will be attempted in the source string. This value always begins as 0.
- `multiline`—A Boolean value indicating whether the `m` flag has been set.
- `source`—The string source of the regular expression. This is always returned as if specified in literal form (without opening and closing slashes) rather than a string pattern as passed into the constructor.
- `flags`—The string flags of the regular expression. This is always returned as if specified in literal form (without opening and closing slashes) rather than a string pattern as passed into the constructor.

These properties are helpful in identifying aspects of a regular expression; however, they typically don't have much use, because the information is available in the pattern declaration. Here's an example:

```
let pattern1 = /[bc]at/i;

console.log(pattern1.global); // false
console.log(pattern1.ignoreCase); // true
console.log(pattern1.multiline); // false
console.log(pattern1.lastIndex); // 0
console.log(pattern1.source); // "[bc]at"
console.log(pattern1.flags); // "i"

let pattern2 = new RegExp("[bc]at", "i");

console.log(pattern2.global); // false
console.log(pattern2.ignoreCase); // true
console.log(pattern2.multiline); // false
console.log(pattern2.lastIndex); // 0
console.log(pattern2.source); // "[bc]at"
console.log(pattern2.flags); // "i"
```

Note that the `source` and `flags` properties of each pattern are equivalent even though the first pattern is in literal form and the second uses the `RegExp` constructor. The `source` and `flags` properties normalize the string into the form you'd use in a literal.

RegExp Instance Methods

The primary method of a `RegExp` object is `exec()`, which is intended for use with capturing groups. This method accepts a single argument, which is the string on which to apply the pattern, and returns an array of information about the first match or `null` if no match was found. The returned array, though an instance of `Array`, contains two additional properties: `index`, which is the location in the string where the pattern was matched, and `input`, which is the string that the expression was run against. In the array, the first item is the string that matches the entire pattern. Any additional items represent captured groups inside the expression (if there are no capturing groups in the pattern, then the array has only one item). Consider the following:

```
let text = "mom and dad and baby";
let pattern = /mom( and dad( and baby)?)?/gi;

let matches = pattern.exec(text);
console.log(matches.index); // 0
console.log(matches.input); // "mom and dad and baby"
console.log(matches[0]); // "mom and dad and baby"
console.log(matches[1]); // " and dad and baby"
console.log(matches[2]); // " and baby"
```

In this example, the pattern has two capturing groups. The innermost one matches " and baby", and its enclosing group matches " and dad" or " and dad and baby". When `exec()` is called on the string, a match is found. Because the entire string matches the pattern, the `index` property on the `matches` array is set to 0. The first item in the array is the entire matched string, the second contains the contents of the first capturing group, and the third contains the contents of the third capturing group.

The `exec()` method returns information about one match at a time even if the pattern is global. When the global flag is not specified, calling `exec()` on the same string multiple times will always return information about the first match.

```
let text = "cat, bat, sat, fat";
let pattern = /.at/;

let matches = pattern.exec(text);
console.log(matches.index); // 0
console.log(matches[0]); // cat
console.log(pattern.lastIndex); // 0

matches = pattern.exec(text);
console.log(matches.index); // 0
console.log(matches[0]); // cat
console.log(pattern.lastIndex); // 0
```

The pattern in this example is not global, so each call to `exec()` returns the first match only ("cat"). `lastIndex` remains unchanged in nonglobal mode.

With the global `g` flag set on the pattern, each call to `exec()` moves further into the string looking for matches, as in this example:

```
let text = "cat, bat, sat, fat";
let pattern = /.at/g;
```

```

let matches = pattern.exec(text);
console.log(matches.index);      // 0
console.log(matches[0]);        // cat
console.log(pattern.lastIndex); // 3

matches = pattern.exec(text);
console.log(matches.index);      // 5
console.log(matches[0]);        // bat
console.log(pattern.lastIndex); // 8

matches = pattern.exec(text);
console.log(matches.index);      // 10
console.log(matches[0]);        // sat
console.log(pattern.lastIndex); // 13

```

This pattern is global, so each call to `exec()` returns the next match in the string until the end of the string is reached. Note also how the pattern's `lastIndex` property is affected. In global matching mode, `lastIndex` is incremented after each call to `exec()`. `lastIndex` tracks the index of the character that appears immediately to the right of the last match.

With the sticky `y` flag set on the pattern, each call to `exec()` will search for a match in the string only at `lastIndex`—nowhere else. The sticky flag overrides the global flag.

```

let text = "cat, bat, sat, fat";
let pattern = /.at/y;

let matches = pattern.exec(text);
console.log(matches.index);      // 0
console.log(matches[0]);        // cat
console.log(pattern.lastIndex); // 3

// There is no match starting at character index 3, so exec() will return null
// exec() finding no matches resets lastIndex to 0
matches = pattern.exec(text);
console.log(matches);           // null
console.log(pattern.lastIndex); // 0

// Advancing lastIndex will allow a sticky regex exec() to find the next match:
pattern.lastIndex = 5;
matches = pattern.exec(text);
console.log(matches.index);      // 5
console.log(matches[0]);        // bat
console.log(pattern.lastIndex); // 8

```

Another method of regular expressions is `test()`, which accepts a string argument and returns `true` if the pattern matches the argument and `false` if it does not. This method is useful when you want to know if a pattern is matched, but you have no need for the actual matched text. The `test()` method is often used in `if` statements, such as the following:

```

let text = "000-00-0000";
let pattern = /\d{3}-\d{2}-\d{4}/;

if (pattern.test(text)) {
  console.log("The pattern was matched.");
}

```

In this example, the regular expression tests for a specific numeric sequence. If the input text matches the pattern, then a message is displayed. This functionality is often used for validating user input, when you care only if the input is valid, not necessarily why it's invalid.

The inherited methods of `toLocaleString()` and `toString()` each return the literal representation of the regular expression, regardless of how it was created. Consider this example:

```
let pattern = new RegExp("\\[bc\\]at", "gi");
console.log(pattern.toString()); // /\[bc\]at/gi
console.log(pattern.toLocaleString()); // /\[bc\]at/gi
```

Even though the pattern in this example is created using the `RegExp` constructor, the `toLocaleString()` and `toString()` methods return the pattern as if it were specified in literal format.

NOTE *The `valueOf()` method for a regular expression returns the regular expression itself.*

RegExp Constructor Properties

The `RegExp` constructor function has several properties. (These would be considered static properties in other languages.) These properties apply to all regular expressions that are in scope, and they change based on the last regular-expression operation that was performed. Another unique element of these properties is that they can be accessed in two different ways. Each property has a verbose property name and a shorthand name. The `RegExp` constructor properties are listed in the following table.

VERBOSE NAME	SHORT NAME	DESCRIPTION
<code>input</code>	<code>\$_</code>	The last string matched against.
<code>lastMatch</code>	<code>\$&</code>	The last matched text.
<code>lastParen</code>	<code>\$+</code>	The last matched capturing group.
<code>leftContext</code>	<code>\$^</code>	The text that appears in the <code>input</code> string prior to <code>lastMatch</code> .
<code>rightContext</code>	<code>\$'</code>	The text that appears in the <code>input</code> string after <code>lastMatch</code> .

These properties can be used to extract specific information about the operation performed by `exec()` or `test()`. Consider this example:

```
let text = "this has been a short summer";
let pattern = /(.)hort/g;

if (pattern.test(text)) {
  console.log(RegExp.input); // this has been a short summer
  console.log(RegExp.leftContext); // this has been a
  console.log(RegExp.rightContext); // summer
  console.log(RegExp.lastMatch); // short
  console.log(RegExp.lastParen); // s
}
```

This code creates a pattern that searches for any character followed by "hort" and puts a capturing group around the first letter. The various properties are used as follows:

- The `input` property contains the original string.
- The `leftContext` property contains the characters of the string before the word "short", and the `rightContext` property contains the characters after the word "short".
- The `lastMatch` property contains the last string that matches the entire regular expression, which is "short".
- The `lastParen` property contains the last matched capturing group, which is "s" in this case.

These verbose property names can be replaced with the short property names, although you must use bracket notation to access them, as shown in the following example, because most are illegal identifiers in ECMAScript:

```
let text = "this has been a short summer";
let pattern = /(.)hort/g;

/*
 * Note: Opera doesn't short property names.
 * Internet Explorer doesn't support multiline.
 */
if (pattern.test(text)) {
  console.log(RegExp.$_);           // this has been a short summer
  console.log(RegExp["$~"]);       // this has been a
  console.log(RegExp["$'"]);       // summer
  console.log(RegExp["$&"]);       // short
  console.log(RegExp["$+"]);       // s
  console.log(RegExp["$*"]);       // false
}
```

There are also constructor properties that store up to nine capturing-group matches. These properties are accessed via `RegExp.$1`, which contains the first capturing-group match through `RegExp.$9`, which contains the ninth capturing-group match. These properties are filled in when calling either `exec()` or `test()`, allowing you to do things like this:

```
let text = "this has been a short summer";
let pattern = /(..)or(./g;

if (pattern.test(text)) {
  console.log(RegExp.$1); // sh
  console.log(RegExp.$2); // t
}
```

In this example, a pattern with two matching groups is created and tested against a string. Even though `test()` simply returns a Boolean value, the properties `$1` and `$2` are filled in on the `RegExp` constructor.

NOTE *All these `RegExp` constructor properties are not part of any web standard; avoid use in any production application.*

Pattern Limitations

Although ECMAScript’s regular-expression support is fully developed, it does lack some of the advanced regular-expression features available in languages such as Perl. The following features are not supported in ECMAScript regular expressions (for more information, see www.regular-expressions.info):

- The `\A` and `\Z` anchors (matching the start or end of a string, respectively)
- Lookbehinds
- Union and intersection classes
- Atomic grouping
- Unicode support (except for matching a single character at a time)
- Named capturing groups
- The `s` (single-line) and `x` (free-spacing) matching modes
- Conditionals
- Regular-expression comments

Despite these limitations, ECMAScript’s regular-expression support is powerful enough to perform most pattern-matching tasks.

PRIMITIVE WRAPPER TYPES

Three special reference types are designed to ease interaction with primitive values: the `Boolean` type, the `Number` type, and the `String` type. These types can act like the other reference types described in this chapter, but they also have a special behavior related to their primitive-type equivalents. Every time a primitive value is read, an object of the corresponding primitive wrapper type is created behind the scenes, allowing access to any number of methods for manipulating the data. Consider the following example:

```
let s1 = "some text";
let s2 = s1.substring(2);
```

In this code, `s1` is a variable containing a string, which is a primitive value. On the next line, the `substring()` method is called on `s1` and stored in `s2`. Primitive values aren’t objects, so logically they shouldn’t have methods, though this still works as you would expect. In truth, there is a lot going on behind the scenes to allow this seamless operation. When `s1` is accessed in the second line, it is being accessed in read mode, which is to say that its value is being read from memory. Any time a string value is accessed in read mode, the following three steps occur:

1. Create an instance of the `String` type.
2. Call the specified method on the instance.
3. Destroy the instance.

You can think of these three steps as they're used in the following three lines of ECMAScript code:

```
let s1 = new String("some text");
let s2 = s1.substring(2);
s1 = null;
```

This behavior allows the primitive string value to act like an object. These same three steps are repeated for Boolean and numeric values using the `Boolean` and `Number` types, respectively.

The major difference between reference types and primitive wrapper types is the lifetime of the object. When you instantiate a reference type using the `new` operator, it stays in memory until it goes out of scope, whereas automatically created primitive wrapper objects exist for only one line of code before they are destroyed. This means that properties and methods cannot be added at runtime. Take this for example:

```
let s1 = "some text";
s1.color = "red";
console.log(s1.color); // undefined
```

Here, the second line attempts to add a `color` property to the string `s1`. However, when `s1` is accessed on the third line, the `color` property is gone. This happens because the `String` object that was created in the second line is destroyed by the time the third line is executed. The third line creates its own `String` object, which doesn't have the `color` property.

It is possible to create the primitive wrapper objects explicitly using the `Boolean`, `Number`, and `String` constructors. This should be done only when absolutely necessary because it is often confusing for developers as to whether they are dealing with a primitive or reference value. Calling `typeof` on an instance of a primitive wrapper type returns `"object"`, and all primitive wrapper objects convert to the Boolean value `true`.

The `Object` constructor also acts as a factory method and is capable of returning an instance of a primitive wrapper based on the type of value passed into the constructor. For example:

```
let obj = new Object("some text");
console.log(obj instanceof String); // true
```

When a string is passed into the `Object` constructor, an instance of `String` is created; a number argument results in an instance of `Number`, while a Boolean argument returns an instance of `Boolean`.

Keep in mind that calling a primitive wrapper constructor using `new` is not the same as calling the casting function of the same name. For example:

```
let value = "25";
let number = Number(value); // casting function
console.log(typeof number); // "number"
let obj = new Number(value); // constructor
console.log(typeof obj); // "object"
```

In this example, the variable `number` is filled with a primitive number value of 25 while the variable `obj` is filled with an instance of `Number`.

Even though it's not recommended to create primitive wrapper objects explicitly, their functionality is important in being able to manipulate primitive values. Each primitive wrapper type has methods that make data manipulation easier.

The Boolean Type

The `Boolean` type is the reference type corresponding to the Boolean values. To create a `Boolean` object, use the `Boolean` constructor and pass in either `true` or `false`, as in the following example:

```
let booleanObject = new Boolean(true);
```

Instances of `Boolean` override the `valueOf()` method to return a primitive value of either `true` or `false`. The `toString()` method is also overridden to return a string of `"true"` or `"false"` when called. Unfortunately, not only are `Boolean` objects of little use in ECMAScript, but they can actually be rather confusing. The problem typically occurs when trying to use `Boolean` objects in Boolean expressions, as in this example:

```
let falseObject = new Boolean(false);
let result = falseObject && true;
console.log(result); // true

let falseValue = false;
result = falseValue && true;
console.log(result); // false
```

In this code, a `Boolean` object is created with a value of `false`. That same object is then ANDed with the primitive value `true`. In Boolean math, `false AND true` equals `false`. However, in this line of code, it is the object named `falseObject` being evaluated, not its value (`false`). As discussed earlier, all objects are automatically converted to `true` in Boolean expressions, so `falseObject` actually is given a value of `true` in the expression. Then, `true ANDed with true` is equal to `true`.

There are a couple of other differences between the primitive and the reference Boolean types. The `typeof` operator returns `"boolean"` for the primitive but `"object"` for the reference. Also, a `Boolean` object is an instance of the `Boolean` type and will return `true` when used with the `instanceof` operator, whereas a primitive value returns `false`, as shown here:

```
console.log(typeof falseObject); // object
console.log(typeof falseValue); // boolean
console.log(falseObject instanceof Boolean); // true
console.log(falseValue instanceof Boolean); // false
```

It's very important to understand the difference between a primitive Boolean value and a `Boolean` object—prefer to never use the latter.

The Number Type

The `Number` type is the reference type for numeric values. To create a `Number` object, use the `Number` constructor and pass in any number. Here's an example:

```
let numberObject = new Number(10);
```

As with the `Boolean` type, the `Number` type overrides `valueOf()`, `toLocaleString()`, and `toString()`. The `valueOf()` method returns the primitive numeric value represented by the object, whereas the other two methods return the number as a string. The `toString()` method optionally accepts a single argument indicating the radix in which to represent the number, as shown in the following examples:

```
let num = 10;
console.log(num.toString()); // "10"
```

```
console.log(num.toString(2)); // "1010"
console.log(num.toString(8)); // "12"
console.log(num.toString(10)); // "10"
console.log(num.toString(16)); // "a"
```

Aside from the inherited methods, the `Number` type has several additional methods used to format numbers as strings.

The `toFixed()` method returns a string representation of a number with a specified number of decimal points, as in this example:

```
let num = 10;
console.log(num.toFixed(2)); // "10.00"
```

Here, the `toFixed()` method is given an argument of 2, which indicates how many decimal places should be displayed. As a result, the method returns the string `"10.00"`, filling out the empty decimal places with zeros. If the number has more than the given number of decimal places, the result is rounded to the nearest decimal place, as shown here:

```
let num = 10.005;
console.log(num.toFixed(2)); // "10.01"
```

The rounding nature of `toFixed()` may be useful for applications dealing with currency, though it's worth noting that arithmetic operations between multiple floating point values may not produce exact results—for example, $0.1 + 0.2 = 0.30000000000000004$.

NOTE *The `toFixed()` method can represent numbers with 0 through 20 decimal places. Some browsers may support larger ranges, but this is the typically implemented range.*

Another method related to formatting numbers is the `toExponential()` method, which returns a string with the number formatted in exponential notation (aka e-notation). Just as with `toFixed()`, `toExponential()` accepts one argument, which is the number of decimal places to output. Consider this example:

```
let num = 10;
console.log(num.toExponential(1)); // "1.0e+1"
```

This code outputs `"1.0e+1"` as the result. Typically, this small number wouldn't be represented using e-notation. If you want to have the most appropriate form of the number, the `toPrecision()` method should be used instead.

The `toPrecision()` method returns either the fixed or the exponential representation of a number, depending on which makes the most sense. This method takes one argument, which is the total number of digits to use to represent the number (not including exponents). Here's an example:

```
let num = 99;
console.log(num.toPrecision(1)); // "1e+2"
console.log(num.toPrecision(2)); // "99"
console.log(num.toPrecision(3)); // "99.0"
```

In this example, the first task is to represent the number 99 with a single digit, which results in "1e+2", otherwise known as 100. Because 99 cannot accurately be represented by just one digit, the method rounded up to 100, which can be represented using just one digit. Representing 99 with two digits yields "99" and with three digits returns "99.0". The `toFixed()` method essentially determines whether to call `toFixed()` or `toExponential()` based on the numeric value you're working with; all three methods round up or down to accurately represent a number with the correct number of decimal places.

NOTE *The `toFixed()` method can represent numbers with 1 through 21 decimal places. Some browsers may support larger ranges, but this is the typically implemented range.*

Similar to the `Boolean` object, the `Number` object gives important functionality to numeric values but really should not be instantiated directly because of the same potential problems. The `typeof` and `instanceof` operators work differently when dealing with primitive numbers versus reference numbers, as shown in the following examples:

```
let numberObject = new Number(10);
let numberValue = 10;
console.log(typeof numberObject);    // "object"
console.log(typeof numberValue);     // "number"
console.log(numberObject instanceof Number); // true
console.log(numberValue instanceof Number); // false
```

Primitive numbers always return "number" when `typeof` is called on them, whereas `Number` objects return "object". Similarly, a `Number` object is an instance of `Number`, but a primitive number is not.

The `isInteger()` Method and Safe Integers

Newly introduced in ES6, the `Number.isInteger()` method is capable of discerning whether or not a number value is stored as an integer or not. This is useful when a trailing decimal 0 may mask whether or not the number is actually stored in floating point format:

```
console.log(Number.isInteger(1));    // true
console.log(Number.isInteger(1.00)); // true
console.log(Number.isInteger(1.01)); // false
```

The IEEE 754 number format has a distinct numerical range inside which a binary value can represent exactly one integer value. This numerical range extends from `Number.MIN_SAFE_INTEGER`, or $-2^{53} + 1$, to `Number.MAX_SAFE_INTEGER`, or $2^{53} - 1$. Outside this range, you may attempt to store an integer, but the IEEE 754 encoding format means that this binary value may also alias to a completely different number. To ascertain if an integer is inside this range, the `Number.isSafeInteger()` method allows you to easily check this:

```
console.log(Number.isSafeInteger(-1 * (2 ** 53))); // false
console.log(Number.isSafeInteger(-1 * (2 ** 53) + 1)); // true

console.log(Number.isSafeInteger(2 ** 53)); // false
console.log(Number.isSafeInteger((2 ** 53) - 1)); // true
```

The String Type

The `String` type is the object representation for strings and is created using the `String` constructor as follows:

```
let stringObject = new String("hello world");
```

The methods of a `String` object are available on all string primitives. All three of the inherited methods—`valueOf()`, `toLocaleString()`, and `toString()`—return the object's primitive string value.

Each instance of `String` contains a single property, `length`, which indicates the number of characters in the string. Consider the following example:

```
let stringValue = "hello world";
console.log(stringValue.length); // "11"
```

This example outputs "11", the number of characters in "hello world". Note that even if the string contains a double-byte character (as opposed to an ASCII character, which uses just one byte), each character is still counted as one.

The `String` type has a large number of methods to aid in the dissection and manipulation of strings in ECMAScript.

The JavaScript Character

JavaScript strings consist of 16 bit code units. For most characters, each 16 bit code unit will correspond to a single character. The `length` property indicates how many 16 bit code units occur inside the string:

```
let message = "abcde";

console.log(message.length); // 5
```

Furthermore, the `charAt()` returns the character at a given index, specified by an integer argument to the method. Specifically, this method finds the 16 bit code unit at the specified index and returns the character that corresponds to that code unit:

```
let message = "abcde";

console.log(message.charAt(2)); // "c"
```

JavaScript strings use a hybridized strategy of two Unicode encodings: UCS-2 and UTF-16. For characters which can be encoded with 16 bits (U+0000 to U+FFFF), these two encodings are effectively identical.

NOTE *For in-depth coverage of character encoding, check out Joel Spolsky's excellent blog post:* <https://www.joelonsoftware.com/2003/10/08/the-absolute-minimum-every-software-developer-absolutely-positively-must-know-about-unicode-and-character-sets-no-excuses/>.

Another good resource is Mathias Bynens' blog post: <https://mathiasbynens.be/notes/javascript-encoding>.

You can inspect the character encoding of a given code unit with the `charCodeAt()` method. This method returns the code unit value at a given index, specified by an integer argument to the method. This method is demonstrated here:

```
let message = "abcde";

// Unicode "Latin small letter C" is U+0063
console.log(message.charCodeAt(2)); // 99

// Decimal 99 === Hexadecimal 63
console.log(99 === 0x63); // true
```

The `fromCharCode()` method is used for creating characters in a string from their UTF-16 code unit representation. This method accepts any number of numbers and returns their character equivalents concatenated into a string:

```
// Unicode "Latin small letter A" is U+0061
// Unicode "Latin small letter B" is U+0062
// Unicode "Latin small letter C" is U+0063
// Unicode "Latin small letter D" is U+0064
// Unicode "Latin small letter E" is U+0065

console.log(String.fromCharCode(0x61, 0x62, 0x63, 0x64, 0x65)); // "abcde"

// 0x0061 === 97
// 0x0062 === 98
// 0x0063 === 99
// 0x0064 === 100
// 0x0065 === 101

console.log(String.fromCharCode(97, 98, 99, 100, 101)); // "abcde"
```

For characters in the range of U+0000 to U+FFFF, `length`, `charAt()`, `charCodeAt()`, and `fromCharCode()` all behave exactly as you would expect them to. This is because every character is represented by exactly 16 bits, and each of these methods are all operating on 16 bit code units. As long as there is parity between character encoding size and code unit size, these methods will behave as expected.

This parity breaks down when expanding into the realm of Unicode supplementary character planes. The idea for this concept is relatively straightforward: 16 bits can only uniquely represent 65,536 characters. This is enough to cover most language character sets and is referred to as the *Basic Multilingual Plane (BMP)*. In order to introduce even more characters, Unicode defined a strategy which used an additional 16 bits per character to select a *supplementary* or *astral plane*. Using two 16 bit code units per character is referred to as a *surrogate pair*.

With the introduction of this convention, the previously discussed string methods begin to break down. Consider the following example, which uses a smiley face emoji – a character which is encoded using a surrogate pair:

```
// The "smiling face with smiling eyes" emoji is U+1F60A
// 0x1F60A === 128522
let message = "ab@de";

console.log(message.length); // 6
```

```

console.log(message.charAt(1)); // b
console.log(message.charAt(2)); // <?>
console.log(message.charAt(3)); // <?>
console.log(message.charAt(4)); // d

console.log(message.charCodeAt(1)); // 98
console.log(message.charCodeAt(2)); // 55357
console.log(message.charCodeAt(3)); // 56842
console.log(message.charCodeAt(4)); // 100

console.log(String.fromCharCode(0x1F60A)); // ☺

console.log(String.fromCharCode(97, 98, 55357, 56842, 100, 101)); // ab☺de

```

These methods are still treating each 16 bit code unit like a separate character, when in fact the code units at index 2 and 3 need to be considered together as a single surrogate pair to form a single character. The `fromCharCode()` method is still working correctly using the two code units separated because this method is literally assembling the string from a provided binary representation. The browser is able to correctly parse the surrogate pair (which was assembled as two separate code units) and correctly interpret it as a single smiley face Unicode character.

To correctly parse a string containing both single-code unit and surrogate pair characters, the `codePointAt()` method can be used instead of the error-prone `charAt()`. As is the case with `charAt()`, this method accepts a 16 bit code unit index and returns the code point at that index. A *code point* refers to the full Unicode identifier for a single character. The code point for "c" is 0x0063. The code point for "☺" is 0x1F60A. Code points may either require 16 or 32 bits to fully represent them, and the `codePointAt()` method will identify the full code point beginning at the specified code unit.

```

let message = "ab☺de";

console.log(message.codePointAt(1)); // 98
console.log(message.codePointAt(2)); // 128522
console.log(message.codePointAt(3)); // 56842
console.log(message.codePointAt(4)); // 100

```

Notice in this example how a code point can be incorrectly identified if targeted at a code unit index that is not the start of a surrogate pair. This is only problematic for one-off character inspection, and can be averted by traversing the string from left to right and advancing the proper number of code units per iterator. The iterator for a string is intelligent enough to identify surrogate pair code points:

```

console.log([... "ab☺de"]); // ["a", "b", "☺", "d", "e"]

```

Just as `charAt()` has an analogue in `codePointAt()`, `fromCharCode()` has an analogue in `fromCodePoint()`. This method accepts any number of code point numbers and returns their character equivalents concatenated into a string:

```

console.log(String.fromCharCode(97, 98, 55357, 56842, 100, 101)); // ab☺de
console.log(String.fromCodePoint(97, 98, 128522, 100, 101)); // ab☺de

```

The normalize() Method

Some Unicode characters can be encoded in more than one way. Sometimes, a character can be represented by either a single BMP character or a surrogate pair. For example, consider the following:

```
// U+00C5: Latin capital letter A with ring above
console.log(String.fromCharCode(0x00C5));           // Å

// U+212B: Angstrom sign
console.log(String.fromCharCode(0x212B));           // Å

// U+0041: Latin captal letter A
// U+030A: Combining ring above
console.log(String.fromCharCode(0x0041, 0x030A));   // Å
```

Comparison operators do not care about the visual appearance of characters, and so these three will be considered distinct:

```
let a1 = String.fromCharCode(0x00C5),
    a2 = String.fromCharCode(0x212B),
    a3 = String.fromCharCode(0x0041, 0x030A);

console.log(a1, a2, a3); // Å, Å, Å

console.log(a1 === a2); // false
console.log(a1 === a3); // false
console.log(a2 === a3); // false
```

Unicode accounts for this by offering four normalization forms by which characters such as this one can be normalized into a consistent format irrespective of their character code derivation. These four normalization forms, Normalization Form D (NFD), Normalization Form C (NFC), Normalization Form KD (NFKD), and Normalization Form KC (NFKC), can be applied to a string using the `normalize()` method. This method should be provided with a string identifier to specify which normalization form to apply: `NFD`, `NFC`, `NFKD`, or `NFKC`.

NOTE *The specifics of each of these normal forms is out of the scope of this text. Refer to <http://unicode.org/reports/tr15/> for additional details.*

It is possible to determine if a string is already normalized by checking it against the return value of `normalize()`:

```
let a1 = String.fromCharCode(0x00C5),
    a2 = String.fromCharCode(0x212B),
    a3 = String.fromCharCode(0x0041, 0x030A);

// U+00C5 is the NFC/NFKC normalized form of 0+212B
console.log(a1 === a1.normalize("NFD")); // false
console.log(a1 === a1.normalize("NFC")); // true
console.log(a1 === a1.normalize("NFKD")); // false
console.log(a1 === a1.normalize("NFKC")); // true
```

```
// U+212B is non-normalized
console.log(a2 === a2.normalize("NFD")); // false
console.log(a2 === a2.normalize("NFC")); // false
console.log(a2 === a2.normalize("NFKD")); // false
console.log(a2 === a2.normalize("NFKC")); // false

// U+0041/U+030A is the NFD/NFKD normalized form of 0+212B
console.log(a3 === a3.normalize("NFD")); // true
console.log(a3 === a3.normalize("NFC")); // false
console.log(a3 === a3.normalize("NFKD")); // true
console.log(a3 === a3.normalize("NFKC")); // false
```

Selecting a normal form will allow for the comparison operator to behave as expected between identical characters:

```
let a1 = String.fromCharCode(0x00C5),
    a2 = String.fromCharCode(0x212B),
    a3 = String.fromCharCode(0x0041, 0x030A);

console.log(a1.normalize("NFD") === a2.normalize("NFD")); // true
console.log(a2.normalize("NFKC") === a3.normalize("NFKC")); // true
console.log(a1.normalize("NFC") === a3.normalize("NFC")); // true
```

String-Manipulation Methods

Several methods manipulate the values of strings. The first of these methods is `concat()`, which is used to concatenate one or more strings to another, returning the concatenated string as the result. Consider the following example:

```
let stringValue = "hello ";
let result = stringValue.concat("world");

console.log(result); // "hello world"
console.log(stringValue); // "hello"
```

The result of calling the `concat()` method on `stringValue` in this example is "hello world"—the value of `stringValue` remains unchanged. The `concat()` method accepts any number of arguments, so it can create a string from any number of other strings, as shown here:

```
let stringValue = "hello ";
let result = stringValue.concat("world", "!");

console.log(result); // "hello world!"
console.log(stringValue); // "hello"
```

This modified example concatenates "world" and "!" to the end of "hello". Although the `concat()` method is provided for string concatenation, the addition operator (+) is used more often and, in most cases, actually performs better than the `concat()` method even when concatenating multiple strings.

ECMAScript provides three methods for creating string values from a substring: `slice()`, `substr()`, and `substring()`. All three methods return a substring of the string they act on, and all accept either one or two arguments. The first argument is the position where capture of the substring begins; the second argument, if used, indicates where the operation should stop. For `slice()` and `substring()`, this second argument is the position before which capture is stopped (all characters up to this point

are included except the character at that point). For `substr()`, the second argument is the number of characters to return. If the second argument is omitted in any case, it is assumed that the ending position is the length of the string. Just as with the `concat()` method, `slice()`, `substr()`, and `substring()` do not alter the value of the string itself—they simply return a primitive string value as the result, leaving the original unchanged. Consider this example:

```
let stringValue = "hello world";
console.log(stringValue.slice(3));      // "lo world"
console.log(stringValue.substring(3));  // "lo world"
console.log(stringValue.substr(3));     // "lo world"
console.log(stringValue.slice(3, 7));   // "lo w"
console.log(stringValue.substring(3,7)); // "lo w"
console.log(stringValue.substr(3, 7));  // "lo worl"
```

In this example, `slice()`, `substr()`, and `substring()` are used in the same manner and, in most cases, return the same value. When given just one argument, 3, all three methods return "lo world" because the second "l" in "hello" is in position 3. When given two arguments, 3 and 7, `slice()` and `substring()` return "lo w" (the "o" in "world" is in position 7, so it is not included), while `substr()` returns "lo worl" because the second argument specifies the number of characters to return.

There are different behaviors for these methods when an argument is a negative number. For the `slice()` method, a negative argument is treated as the length of the string plus the negative argument.

For the `substr()` method, a negative first argument is treated as the length of the string plus the number, whereas a negative second number is converted to 0. For the `substring()` method, all negative numbers are converted to 0. Consider this example:

```
let stringValue = "hello world";
console.log(stringValue.slice(-3));     // "rld"
console.log(stringValue.substring(-3)); // "hello world"
console.log(stringValue.substr(-3));    // "rld"
console.log(stringValue.slice(3, -4));  // "lo w"
console.log(stringValue.substring(3, -4)); // "hel"
console.log(stringValue.substr(3, -4));  // "" (empty string)
```

This example clearly indicates the differences between three methods. When `slice()` and `substr()` are called with a single negative argument, they act the same. This occurs because `-3` is translated into 7 (the length plus the argument), effectively making the calls `slice(7)` and `substr(7)`. The `substring()` method, on the other hand, returns the entire string because `-3` is translated to 0.

When the second argument is negative, the three methods act differently from one another. The `slice()` method translates the second argument to 7, making the call equivalent to `slice(3, 7)` and so returning "lo w". For the `substring()` method, the second argument gets translated to 0, making the call equivalent to `substring(3, 0)`, which is actually equivalent to `substring(0, 3)` because this method expects that the smaller number is the starting position and the larger one is the ending position. For the `substr()` method, the second argument is also converted to 0, which means there should be zero characters in the returned string, leading to the return value of an empty string.

String Location Methods

There are two methods for locating substrings within another string: `indexOf()` and `lastIndexOf()`. Both methods search a string for a given substring and return the position (or `-1` if the substring isn't found). The difference between the two is that the `indexOf()` method begins looking for the substring at the beginning of the string, whereas the `lastIndexOf()` method begins looking from the end of the string. Consider this example:

```
let stringValue = "hello world";
console.log(stringValue.indexOf("o"));    // 4
console.log(stringValue.lastIndexOf("o")); // 7
```

Here, the first occurrence of the string `"o"` is at position 4, which is the `"o"` in `"hello"`. The last occurrence of the string `"o"` is in the word `"world"`, at position 7. If there is only one occurrence of `"o"` in the string, then `indexOf()` and `lastIndexOf()` return the same position.

Each method accepts an optional second argument that indicates the position to start searching from within the string. This means that the `indexOf()` method will start searching from that position and go toward the end of the string, ignoring everything before the start position, whereas `lastIndexOf()` starts searching from the given position and continues searching toward the beginning of the string, ignoring everything between the given position and the end of the string. Here's an example:

```
let stringValue = "hello world";
console.log(stringValue.indexOf("o", 6));    // 7
console.log(stringValue.lastIndexOf("o", 6)); // 4
```

When the second argument of `6` is passed into each method, the results are the opposite from the previous example. This time, `indexOf()` returns `7` because it starts searching the string from position `6` (the letter `"w"`) and continues to position `7`, where `"o"` is found. The `lastIndexOf()` method returns `4` because the search starts from position `6` and continues back toward the beginning of the string, where it encounters the `"o"` in `"hello"`. Using this second argument allows you to locate all instances of a substring by looping callings to `indexOf()` or `lastIndexOf()`, as in the following example:

```
let stringValue = "Lorem ipsum dolor sit amet, consectetur adipisicing elit";
let positions = new Array();
let pos = stringValue.indexOf("e");

while(pos > -1) {
  positions.push(pos);
  pos = stringValue.indexOf("e", pos + 1);
}

console.log(positions); // "3,24,32,35,52"
```

This example works through a string by constantly increasing the position at which `indexOf()` should begin. It begins by getting the initial position of `"e"` in the string and then enters a loop that continually passes in the last position plus one to `indexOf()`, ensuring that the search continues after the last substring instance. Each position is stored in the `positions` array so the data can be used later.

String Inclusion Methods

ECMAScript 6 added three additional methods for determining if a string is included inside another string: `startsWith()`, `endsWith()`, and `includes()`. All methods search a string for a given substring and return a boolean indicating whether it is not included. The difference between them is that `startsWith()` checks for a match beginning at index 0, `endsWith()` checks for a match beginning at index `(string.length - substring.length)`, and `includes()` checks the entire string.

```
let message = "foobarbaz";

console.log(message.startsWith("foo")); // true
console.log(message.startsWith("bar")); // false

console.log(message.endsWith("baz")); // true
console.log(message.endsWith("bar")); // false

console.log(message.includes("bar")); // true
console.log(message.includes("qux")); // false
```

The `startsWith()` and `includes()` methods accept an optional second argument that indicates the position to start searching from within the string. This means that the methods will start searching from that position and go toward the end of the string, ignoring everything before the start position. Here's an example:

```
let message = "foobarbaz";

console.log(message.startsWith("foo")); // true
console.log(message.startsWith("foo", 1)); // false

console.log(message.includes("bar")); // true
console.log(message.includes("bar", 4)); // false
```

The `endsWith()` method accepts an optional second argument that indicates the position that should be treated as the end of the string. If this value is not provided, the length of the string is used by default. When a second argument is provided, the method will treat the string as if it only has that many characters:

```
let message = "foobarbaz";

console.log(message.endsWith("bar")); // false
console.log(message.endsWith("bar", 6)); // true
```

The trim() Method

ECMAScript features a `trim()` method on all strings. The `trim()` method creates a copy of the string, removes all leading and trailing white space, and then returns the result. For example:

```
let stringValue = " hello world ";
let trimmedStringValue = stringValue.trim();
console.log(stringValue); // " hello world "
console.log(trimmedStringValue); // "hello world"
```

Note that since `trim()` returns a copy of a string, the original string remains intact with leading and trailing white space in place.

Also available are the `trimLeft()` and `trimRight()` methods that remove white space only from the beginning or end of the string, respectively.

The repeat() Method

ECMAScript features a `repeat()` method on all strings. The `repeat()` method accepts a single integer argument `count`, copies the string `count` times, and concatenates all the copies.

```
let stringValue = "na ";
console.log(stringValue.repeat(16) + "batman");
// na na na na na na na na na na na na na na na na batman
```

The padStart() and padEnd() Methods

The `padStart()` and `padEnd()` methods will copy a string and, if the length of the string is less than the specified length, add padding to either side of a string to extend it to a certain length. The first argument is the desired length, and the second is the optional string to add as a pad. If not provided, the U+0020 'space' character will be used.

```
let stringValue = "foo";

console.log(stringValue.padStart(6));           // "   foo"
console.log(stringValue.padStart(9, "."));      // ".....foo"

console.log(stringValue.padEnd(6));            // "foo  "
console.log(stringValue.padEnd(9, "."));       // "foo....."
```

The optional argument is not limited to a single character. If provided a multiple-character string, the method will use the concatenated padding and truncate it to the exact length. Additionally, if the length is less than or equal to the string length, the operation is effectively a no-op.

```
let stringValue = "foo";

console.log(stringValue.padStart(8, "bar"));    // "barbafoo"
console.log(stringValue.padStart(2));          // "foo"

console.log(stringValue.padEnd(8, "bar"));     // "foobarba"
console.log(stringValue.padEnd(2));           // "foo"
```

String Iterators and Destructuring

The string prototype exposes an `@@iterator` method on each string, which allows for iteration through individual characters. Manual use of the iterator works as follows:

```
let message = "abc";
let stringIterator = message[Symbol.iterator]();

console.log(stringIterator.next()); // {value: "a", done: false}
console.log(stringIterator.next()); // {value: "b", done: false}
console.log(stringIterator.next()); // {value: "c", done: false}
console.log(stringIterator.next()); // {value: undefined, done: true}
```

When used in a `for of` loop, the loop will use this iterator to visit each character in order:

```
for (const c of "abcde") {
  console.log(c);
}

// a
// b
```

```
// c
// d
// e
```

The string iterator becomes especially useful since it allows for interoperability with the destructuring operator. This allows you to easily split a string by its characters:

```
let message = "abcde";

console.log([...message]); // ["a", "b", "c", "d", "e"]
```

String Case Methods

The next set of methods involves case conversion. Four methods perform case conversion: `toLowerCase()`, `toLocaleLowerCase()`, `toUpperCase()`, and `toLocaleUpperCase()`. The `toLowerCase()` and `toUpperCase()` methods are the original methods, modeled after the same methods in `java.lang.String`. The `toLocaleLowerCase()` and `toLocaleUpperCase()` methods are intended to be implemented based on a particular locale. In many locales, the locale-specific methods are identical to the generic ones; however, a few languages (such as Turkish) apply special rules to Unicode case conversion, and this necessitates using the locale-specific methods for proper conversion. Here are some examples:

```
let stringValue = "hello world";
console.log(stringValue.toLocaleUpperCase()); // "HELLO WORLD"
console.log(stringValue.toUpperCase());      // "HELLO WORLD"
console.log(stringValue.toLocaleLowerCase()); // "hello world"
console.log(stringValue.toLowerCase());      // "hello world"
```

This code outputs "HELLO WORLD" for both `toLocaleUpperCase()` and `toUpperCase()`, just as "hello world" is output for both `toLocaleLowerCase()` and `toLowerCase()`. Generally speaking, if you do not know the language in which the code will be running, it is safer to use the locale-specific methods.

String Pattern-Matching Methods

The `String` type has several methods designed to pattern-match within the string. The first of these methods is `match()` and is essentially the same as calling a `RegExp` object's `exec()` method. The `match()` method accepts a single argument, which is either a regular-expression string or a `RegExp` object. Consider this example:

```
let text = "cat, bat, sat, fat";
let pattern = /.at/;

// same as pattern.exec(text)
let matches = text.match(pattern);
console.log(matches.index); // 0
console.log(matches[0]);   // "cat"
console.log(pattern.lastIndex); // 0
```

The array returned from `match()` is the same array that is returned when the `RegExp` object's `exec()` method is called with the string as an argument: the first item is the string that matches the entire pattern, and each other item (if applicable) represents capturing groups in the expression.

Another method for finding patterns is `search()`. The only argument for this method is the same as the argument for `match()`: a regular expression specified by either a string or a `RegExp` object. The `search()` method returns the index of the first pattern occurrence in the string or `-1` if it's not found. `search()` always begins looking for the pattern at the beginning of the string. Consider this example:

```
let text = "cat, bat, sat, fat";
let pos = text.search(/at/);
console.log(pos); // 1
```

Here, `search(/at/)` returns `1`, which is the first position of `"at"` in the string.

To simplify replacing substrings, ECMAScript provides the `replace()` method. This method accepts two arguments. The first argument can be a `RegExp` object or a string (the string is not converted to a regular expression), and the second argument can be a string or a function. If the first argument is a string, then only the first occurrence of the substring will be replaced. The only way to replace all instances of a substring is to provide a regular expression with the global flag specified, as in this example:

```
let text = "cat, bat, sat, fat";
let result = text.replace("at", "ond");
console.log(result); // "cond, bat, sat, fat"

result = text.replace(/at/g, "ond");
console.log(result); // "cond, bond, sond, fond"
```

In this example, the string `"at"` is first passed into `replace()` with a replacement text of `"ond"`. The result of the operation is that `"cat"` is changed to `"cond"`, but the rest of the string remains intact. By changing the first argument to a regular expression with the global flag set, each instance of `"at"` is replaced with `"ond"`.

When the second argument is a string, there are several special character sequences that can be used to insert values from the regular-expression operations. ECMA-262 specifies the following table of values.

SEQUENCE	REPLACEMENT TEXT
<code>\$\$</code>	<code>\$</code>
<code>\$&</code>	The substring matching the entire pattern. Same as <code>RegExp.lastMatch</code> .
<code>\$'</code>	The part of the string occurring before the matched substring. Same as <code>RegExp.rightContext</code> .
<code>\$`</code>	The part of the string occurring after the matched substring. Same as <code>RegExp.leftContext</code> .
<code>\$n</code>	The <i>n</i> th capture, where <i>n</i> is a value 0–9. For instance, <code>\$1</code> is the first capture, <code>\$2</code> is the second, and so on. If there is no capture then the empty string is used.
<code>\$nn</code>	The <i>nn</i> th capture, where <i>nn</i> is a value 01–99. For instance, <code>\$01</code> is the first capture, <code>\$02</code> is the second, and so on. If there is no capture then the empty string is used.

Using these special sequences allows replacement using information about the last match, such as in this example:

```
let text = "cat, bat, sat, fat";
result = text.replace(/(.at)/g, "word ($1)");
console.log(result); // word (cat), word (bat), word (sat), word (fat)
```

Here, each word ending with "at" is replaced with "word" followed in parentheses by what it replaces by using the \$1 sequence.

The second argument of `replace()` may also be a function. When there is a single match, the function gets passed three arguments: the string match, the position of the match within the string, and the whole string. When there are multiple capturing groups, each matched string is passed in as an argument, with the last two arguments being the position of the pattern match in the string and the original string. The function should return a string indicating what the match should be replaced with. Using a function as the second argument allows more granular control over replacement text, as in this example:

```
function htmlEscape(text) {
  return text.replace(/[\<>"]&/g, function(match, pos, originalText) {
    switch(match) {
      case "<":
        return "&lt;";
      case ">":
        return "&gt;";
      case "&":
        return "&amp;";
      case "\"":
        return "&quot;";
    }
  });
}

console.log(htmlEscape("<p class=\"greeting\">Hello world!</p>"));
// "&lt;p class=&quot;greeting&quot;&gt;Hello world!</p>"
```

Here, the function `htmlEscape()` is defined to escape four characters for insertion into HTML: the less-than, greater-than, ampersand, and double-quote characters all must be escaped. The easiest way to accomplish this is to have a regular expression to look for those characters and then define a function that returns the specific HTML entities for each matched character.

The last string method for dealing with patterns is `split()`, which separates the string into an array of substrings based on a separator. The separator may be a string or a `RegExp` object. (The string is not considered a regular expression for this method.) An optional second argument, the array limit, ensures that the returned array will be no larger than a certain size. Consider this example:

```
let colorText = "red,blue,green,yellow";
let colors1 = colorText.split(","); // ["red", "blue", "green", "yellow"]
let colors2 = colorText.split(",", 2); // ["red", "blue"]
let colors3 = colorText.split(/^[^,]+/); // ["", ",", ",", ",", ",", ",", ""]
```

In this example, the string `colorText` is a comma-separated string of colors. The call to `split(",")` retrieves an array of those colors, splitting the string on the comma character. To truncate the results to only two items, a second argument of 2 is specified. Last, using a regular expression, it's possible

to get an array of the comma characters. Note that in this last call to `split()`, the returned array has an empty string before and after the commas. This happens because the separator specified by the regular expression appears at the beginning of the string (the substring "red") and at the end (the substring "yellow").

The `localeCompare()` Method

The last method is `localeCompare()`, which compares one string to another and returns one of three values as follows:

- If the string should come alphabetically before the string argument, a negative number is returned. (Most often this is `-1`, but it is up to each implementation as to the actual value.)
- If the string is equal to the string argument, `0` is returned.
- If the string should come alphabetically after the string argument, a positive number is returned. (Most often this is `1`, but once again, this is implementation-specific.)

Here's an example:

```
let stringValue = "yellow";
console.log(stringValue.localeCompare("brick")); // 1
console.log(stringValue.localeCompare("yellow")); // 0
console.log(stringValue.localeCompare("zoo")); // -1
```

In this code, the string "yellow" is compared to three different values: "brick", "yellow", and "zoo". Because "brick" comes alphabetically before "yellow", `localeCompare()` returns `1`; "yellow" is equal to "yellow", so `localeCompare()` returns `0` for that line; and "zoo" comes after "yellow", so `localeCompare()` returns `-1` for that line. Once again, because the values are implementation-specific, it is best to use `localeCompare()` as shown in this example:

```
function determineOrder(value) {
  let result = stringValue.localeCompare(value);
  if (result < 0) {
    console.log(`The string 'yellow' comes before the string '${value}'.`);
  } else if (result > 0) {
    console.log(`The string 'yellow' comes after the string '${value}'.`);
  } else {
    console.log(`The string 'yellow' is equal to the string '${value}'.`);
  }
}

determineOrder("brick");
determineOrder("yellow");
determineOrder("zoo");
```

By using this sort of construct, you can be sure that the code works correctly in all implementations.

The unique part of `localeCompare()` is that an implementation's locale (country and language) indicates exactly how this method operates. In the United States, where English is the standard language for ECMAScript implementations, `localeCompare()` is case-sensitive, determining that uppercase letters come alphabetically after lowercase letters. However, this may not be the case in other locales.

HTML Methods

The web browser vendors recognized a need early on to format HTML dynamically using JavaScript. As a result, they extended the specification to include several methods specifically designed to aid in common HTML formatting tasks. The following table enumerates the HTML methods. However, be aware that typically these methods aren't used, because they tend to create non-semantic markup.

METHOD	OUTPUT
<code>anchor(name)</code>	<code>string</code>
<code>big()</code>	<code><big>string</big></code>
<code>bold()</code>	<code>string</code>
<code>fixed()</code>	<code><tt>string</tt></code>
<code>fontcolor(color)</code>	<code>string</code>
<code>fontsize(size)</code>	<code>string</code>
<code>italics()</code>	<code><i>string</i></code>
<code>link(url)</code>	<code>string</code>
<code>small()</code>	<code><small>string</small></code>
<code>strike()</code>	<code><strike>string</strike></code>
<code>sub()</code>	<code><sub>string</sub></code>
<code>sup()</code>	<code><sup>string</sup></code>

SINGLETON BUILT-IN OBJECTS

ECMA-262 defines a built-in object as "any object supplied by an ECMAScript implementation, independent of the host environment, which is present at the start of the execution of an ECMAScript program." This means the developer does not need to explicitly instantiate a built-in object; it is already instantiated. You have already learned about most of the built-in objects, such as `Object`, `Array`, and `String`. There are two singleton built-in objects defined by ECMA-262: `Global` and `Math`.

The Global Object

The `Global` object is the most unique in ECMAScript because it isn't explicitly accessible. ECMA-262 specifies the `Global` object as a sort of catchall for properties and methods that don't otherwise have an owning object. In truth, there is no such thing as a global variable or global function; all variables and functions defined globally become properties of the `Global` object. Functions covered earlier in this book, such as `isNaN()`, `isFinite()`, `parseInt()`, and `parseFloat()`, are actually methods of the `Global` object. In addition to these, there are several other methods available on the `Global` object.

URI-Encoding Methods

The `encodeURIComponent()` and `encodeURI()` methods are used to encode URIs (Uniform Resource Identifiers) to be passed to the browser. To be valid, a URI cannot contain certain characters, such as spaces. The URI-encoding methods encode the URIs so that a browser can still accept and understand them, replacing all invalid characters with a special UTF-8 encoding.

The `encodeURI()` method is designed to work on an entire URI (for instance, `www.wrox.com/illegal value.js`), whereas `encodeURIComponent()` is designed to work solely on a segment of a URI (such as `illegal value.js` from the previous URI). The main difference between the two methods is that `encodeURI()` does not encode special characters that are part of a URI, such as the colon, forward slash, question mark, and pound sign, whereas `encodeURIComponent()` encodes every non-standard character it finds. Consider this example:

```
let uri = "http:// www.wrox.com/illegal value.js#start";

// "http:// www.wrox.com/illegal%20value.js#start"
console.log(encodeURI(uri));

// "http%3A%2F%2Fwww.wrox.com%2Fillegal%20value.js%23start"
console.log(encodeURIComponent(uri));
```

Here, using `encodeURI()` left the value completely intact except for the space, which was replaced with `%20`. The `encodeURIComponent()` method replaced all nonalphanumeric characters with their encoded equivalents. This is why `encodeURI()` can be used on full URIs, whereas `encodeURIComponent()` can be used only on strings that are appended to the end of an existing URI.

NOTE *Generally speaking, you'll use `encodeURIComponent()` much more frequently than `encodeURI()` because it's more common to encode query string arguments separately from the base URI.*

The two counterparts to `encodeURI()` and `encodeURIComponent()` are `decodeURI()` and `decodeURIComponent()`. The `decodeURI()` method decodes only characters that would have been replaced by using `encodeURI()`. For instance, `%20` is replaced with a space, but `%23` is not replaced because it represents a pound sign (`#`), which `encodeURI()` does not replace. Likewise, `decodeURIComponent()` decodes all characters encoded by `encodeURIComponent()`, essentially meaning it decodes all special values. Consider this example:

```
let uri = "http%3A%2F%2Fwww.wrox.com%2Fillegal%20value.js%23start";

// http%3A%2F%2Fwww.wrox.com%2Fillegal value.js%23start
console.log(decodeURI(uri));

// http:// www.wrox.com/illegal value.js#start
console.log(decodeURIComponent(uri));
```

Here, the `uri` variable contains a string that is encoded using `encodeURIComponent()`. The first value output is the result of `decodeURI()`, which replaced only the `%20` with a space. The second value is the output of `decodeURIComponent()`, which replaces all the special characters and outputs a string that has no escaping in it. (This string is not a valid URI.)

NOTE *The URI methods `encodeURIComponent()`, `decodeURI()`, and `decodeURIComponent()` replace the `escape()` and `unescape()` methods, which are deprecated in the ECMA-262 third edition. The URI methods are always preferable, because they encode all Unicode characters, whereas the original methods encode only ASCII characters correctly. Avoid using `escape()` and `unescape()` in production code.*

The eval() Method

The final method is perhaps the most powerful in the entire ECMAScript language: the `eval()` method. This method works like an entire ECMAScript interpreter and accepts one argument, a string of ECMAScript (or JavaScript) to execute. Here's an example:

```
eval("console.log('hi')");
```

This line is functionally equivalent to the following:

```
console.log("hi");
```

When the interpreter finds an `eval()` call, it interprets the argument into actual ECMAScript statements and then inserts it into place. Code executed by `eval()` is considered to be part of the execution context in which the call is made, and the executed code has the same scope chain as that context. This means variables that are defined in the containing context can be referenced inside an `eval()` call, such as in this example:

```
let msg = "hello world";
eval("console.log(msg)"); // "hello world"
```

Here, the variable `msg` is defined outside the context of the `eval()` call, yet the call to `console.log()` still displays the text "hello world" because the second line is replaced with a real line of code. Likewise, you can define a function or variables inside an `eval()` call that can be referenced by the code outside, as follows:

```
eval("function sayHi() { console.log('hi'); }");
sayHi();
```

Here, the `sayHi()` function is defined inside an `eval()` call. Because that call is replaced with the actual function, it is possible to call `sayHi()` on the following line. This works the same for variables:

```
eval("let msg = 'hello world';");
console.log(msg); // "hello world"
```

Any variables or functions created inside of `eval()` will not be hoisted, as they are contained within a string when the code is being parsed. They are created only at the time of `eval()` execution.

In strict mode, variables and functions created inside of `eval()` are not accessible outside, so these last two examples would cause errors. Also, in strict mode, assigning a value to `eval` causes an error:

```
"use strict";
eval = "hi"; // causes error
```

NOTE *The capability to interpret strings of code is very powerful but also very dangerous. Use extreme caution with `eval()`, especially when passing user-entered data into it, as this method exposes a large attack surface for XSS exploits. A mischievous user could insert values that might compromise your site or application security.*

Global Object Properties

The `Global` object has a number of properties, some of which have already been mentioned in this book. The special values of `undefined`, `NaN`, and `Infinity` are all properties of the `Global` object. Additionally, all native reference type constructors, such as `Object` and `Function`, are properties of the `Global` object. The following table lists all of the properties.

PROPERTY	DESCRIPTION
<code>undefined</code>	The special value <code>undefined</code>
<code>NaN</code>	The special value <code>NaN</code>
<code>Infinity</code>	The special value <code>Infinity</code>
<code>Object</code>	Constructor for <code>Object</code>
<code>Array</code>	Constructor for <code>Array</code>
<code>Function</code>	Constructor for <code>Function</code>
<code>Boolean</code>	Constructor for <code>Boolean</code>
<code>String</code>	Constructor for <code>String</code>
<code>Number</code>	Constructor for <code>Number</code>
<code>Date</code>	Constructor for <code>Date</code>
<code>RegExp</code>	Constructor for <code>RegExp</code>
<code>Symbol</code>	Pseudo-constructor for <code>Symbol</code>
<code>Error</code>	Constructor for <code>Error</code>
<code>EvalError</code>	Constructor for <code>EvalError</code>
<code>RangeError</code>	Constructor for <code>RangeError</code>
<code>ReferenceError</code>	Constructor for <code>ReferenceError</code>
<code>SyntaxError</code>	Constructor for <code>SyntaxError</code>
<code>TypeError</code>	Constructor for <code>TypeError</code>
<code>URIError</code>	Constructor for <code>URIError</code>

The Window Object

Though ECMA-262 doesn't indicate a way to access the `Global` object directly, web browsers implement it such that the `window` is the `Global` object's delegate. Therefore, all variables and functions declared in the global scope become properties on `window`. Consider this example:

```
let color = "red";

function sayColor() {
  console.log(window.color);
}

window.sayColor(); // "red"
```

Here, a global variable named `color` and a global function named `sayColor()` are defined. Inside `sayColor()`, the `color` variable is accessed via `window.color` to show that the global variable became a property of `window`. The function is then called directly off of the `window` object as `window.sayColor()`, which pops up the `console.log`.

NOTE *The window object does much more in JavaScript than just implement the ECMAScript Global object. Details of the window object can be found in the Browser Object Model chapter.*

Another way to retrieve the `Global` object is to use the following code:

```
let global = function() {
  return this;
}();
```

This code creates an immediately-invoked function expression that returns the value of `this`. As mentioned previously, the `this` value is equivalent to the `Global` object when a function is executed with no explicit `this` value specified (either by being an object method or via `call()/apply()`). Thus, calling a function that simply returns `this` is a consistent way to retrieve the `Global` object in any execution environment.

The Math Object

ECMAScript provides the `Math` object as a common location for mathematical formulas, information, and computation. The `Math` object offers a number of properties and methods to help these computations.

NOTE *The computations available on the Math object execute faster than if you were to write the computations in JavaScript directly because computations available on the Math object use more efficient implementations in the JavaScript engine and processor instructions. A side-effect of this is that precision of these operations may vary between browsers, operating systems, instruction sets, and hardware.*

Math Object Properties

The `Math` object has several properties, consisting mostly of special values in the world of mathematics. The following table describes these properties.

PROPERTY	DESCRIPTION
<code>Math.E</code>	The value of e , the base of the natural logarithms
<code>Math.LN10</code>	The natural logarithm of 10
<code>Math.LN2</code>	The natural logarithm of 2
<code>Math.LOG2E</code>	The base 2 logarithm of e
<code>Math.LOG10E</code>	The base 10 logarithm of e
<code>Math.PI</code>	The value of π
<code>Math.SQRT1_2</code>	The square root of $\frac{1}{2}$
<code>Math.SQRT2</code>	The square root of 2

Although the meanings and uses of these values are outside the scope of this book, they are defined in the ECMAScript specification and available when you need them.

The `min()` and `max()` Methods

The `Math` object also contains many methods aimed at performing both simple and complex mathematical calculations.

The `min()` and `max()` methods determine which number is the smallest or largest in a group of numbers. These methods accept any number of parameters, as shown in the following example:

```
let max = Math.max(3, 54, 32, 16);
console.log(max); // 54

let min = Math.min(3, 54, 32, 16);
console.log(min); // 3
```

Out of the numbers 3, 54, 32, and 16, `Math.max()` returns the number 54, whereas `Math.min()` returns the number 3. These methods are useful for avoiding extra loops and `if` statements to determine the maximum value out of a group of numbers.

To find the maximum or the minimum value in an array, you can use the spread operator as follows:

```
let values = [1, 2, 3, 4, 5, 6, 7, 8];
let max = Math.max(...values);
```

Rounding Methods

The next group of methods has to do with rounding decimal values into integers. Four methods—`Math.ceil()`, `Math.floor()`, `Math.round()`, and `Math.fround()`—handle rounding in different ways as described here:

- The `Math.ceil()` method represents the ceiling function, which always rounds numbers up to the nearest integer value.
- The `Math.floor()` method represents the floor function, which always rounds numbers down to the nearest integer value.
- The `Math.round()` method represents a standard round function, which rounds up if the number is at least halfway to the next integer value (0.5 or higher) and rounds down if not. This is the way you were taught to round in elementary school.
- The `Math.fround()` method returns the nearest single precision (32 bits) floating point representation of the number.

The following example illustrates how these methods work:

```
console.log(Math.ceil(25.9)); // 26
console.log(Math.ceil(25.5)); // 26
console.log(Math.ceil(25.1)); // 26

console.log(Math.round(25.9)); // 26
console.log(Math.round(25.5)); // 26
console.log(Math.round(25.1)); // 25

console.log(Math.fround(0.4)); // 0.4000000059604645
console.log(Math.fround(0.5)); // 0.5
console.log(Math.fround(25.9)); // 25.899999618530273

console.log(Math.floor(25.9)); // 25
console.log(Math.floor(25.5)); // 25
console.log(Math.floor(25.1)); // 25
```

For all values between 25 and 26 (exclusive), `Math.ceil()` always returns 26 because it will always round up. The `Math.round()` method returns 26 only if the number is 25.5 or greater; otherwise it returns 25. Last, `Math.floor()` returns 25 for all numbers between 25 and 26 (exclusive).

The `random()` Method

The `Math.random()` method returns a random number between the 0 and the 1, not including either 0 or 1. This is a favorite tool of web sites that are trying to display random quotes or random facts upon entry of a web site. You can use `Math.random()` to select numbers within a certain integer range by using the following formula:

```
number = Math.floor(Math.random() * total_number_of_choices + first_possible_value)
```

The `Math.floor()` method is used here because `Math.random()` always returns a decimal value, meaning that multiplying it by a number and adding another still yields a decimal value. So, if you wanted to select a number between 1 and 10, the code would look like this:

```
let num = Math.floor(Math.random() * 10 + 1);
```

You see 10 possible values (1 through 10), with the first possible value being 1. If you want to select a number between 2 and 10, then the code would look like this:

```
let num = Math.floor(Math.random() * 9 + 2);
```

There are only nine numbers when counting from 2 to 10, so the total number of choices is nine, with the first possible value being 2. Many times, it's just easier to use a function that handles the calculation of the total number of choices and the first possible value, as in this example:

```
function selectFrom(lowerValue, upperValue) {
  let choices = upperValue - lowerValue + 1;
  return Math.floor(Math.random() * choices + lowerValue);
}

let num = selectFrom(2,10);
console.log(num); // number between 2 and 10, inclusive
```

Here, the function `selectFrom()` accepts two arguments: the lowest value that should be returned and the highest value that should be returned. The number of choices is calculated by subtracting the two values and adding one and then applying the previous formula to those numbers. So it's possible to select a number between 2 and 10 (inclusive) by calling `selectFrom(2,10)`. Using the function, it's easy to select a random item from an array, as shown here:

```
let colors = ["red", "green", "blue", "yellow", "black", "purple", "brown"];
let color = colors[selectFrom(0, colors.length-1)];
```

In this example, the second argument to `selectFrom()` is the length of the array minus 1, which is the last position in an array.

NOTE *The `Math.random()` method is fine for the purposes demonstrated here. If you need to use random number generation for cryptographic purposes (which requires higher entropy in the inputs to the generator) prefer instead to use `window.crypto.getRandomValues()`.*

Other Methods

The `Math` object has a lot of methods related to various simple and higher-level mathematical operations. It's beyond the scope of this book to discuss the ins and outs of each or in what situations they may be used, but the following table enumerates the remaining methods of the `Math` object.

METHOD	DESCRIPTION
<code>Math.abs(x)</code>	Returns the absolute value of <code>x</code>
<code>Math.exp(x)</code>	Returns <code>Math.E</code> raised to the power of <code>x</code>

METHOD	DESCRIPTION
<code>Math.expm1(x)</code>	Equivalent to <code>Math.exp(x) - 1</code>
<code>Math.log(x)</code>	Returns the natural logarithm of <code>x</code>
<code>Math.log1p(x)</code>	Equivalent to <code>1 + Math.log(x)</code>
<code>Math.pow(x, power)</code>	Returns <code>x</code> raised to the power of <code>power</code>
<code>Math.pow(...nums)</code>	Returns the square root of the sum of the squares of each number in <code>nums</code>
<code>Math.clz32(x)</code>	Returns the number of leading zeroes of a 32-bit integer <code>x</code>
<code>Math.sign(x)</code>	Returns 1, 0, -0, or -1 indicating the sign of <code>x</code>
<code>Math.trunc(x)</code>	Returns the integer component of <code>x</code> , removing any decimals
<code>Math.sqrt(x)</code>	Returns the square root of <code>x</code>
<code>Math.cbrt(x)</code>	Returns the cubic root of <code>x</code>
<code>Math.acos(x)</code>	Returns the arc cosine of <code>x</code>
<code>Math.acosh(x)</code>	Returns the hyperbolic arc cosine of <code>x</code>
<code>Math.asin(x)</code>	Returns the arc sine of <code>x</code>
<code>Math.asinh(x)</code>	Returns the hyperbolic arc sine of <code>x</code>
<code>Math.atan(x)</code>	Returns the arc tangent of <code>x</code>
<code>Math.atanh(x)</code>	Returns the hyperbolic arc tangent of <code>x</code>
<code>Math.atan2(y, x)</code>	Returns the arc tangent of <code>y/x</code>
<code>Math.cos(x)</code>	Returns the cosine of <code>x</code>
<code>Math.sin(x)</code>	Returns the sine of <code>x</code>
<code>Math.tan(x)</code>	Returns the tangent of <code>x</code>

Even though these methods are defined by ECMA-262, the results are implementation-dependent for those dealing with sines, cosines, and tangents, because you can calculate each value in many different ways. Consequently, the precision of the results may vary from one implementation to another.

SUMMARY

Objects in JavaScript are called reference values, and several built-in reference types can be used to create specific types of objects, as follows:

- Reference types are similar to classes in traditional object-oriented programming but are implemented differently.

- The `Date` type provides information about dates and times, including the current date and time and calculations.
- The `RegExp` type is an interface for regular-expression support in ECMAScript, providing most basic and some advanced regular-expression functionality.

One of the unique aspects of JavaScript is that functions are actually instances of the `Function` type, meaning functions are objects. Because functions are objects, functions have methods that can be used to augment how they behave.

Because of the existence of primitive wrapper types, primitive values in JavaScript can be accessed as if they were objects. There are three primitive wrapper types: `Boolean`, `Number`, and `String`. They all have the following characteristics:

- Each of the wrapper types maps to the primitive type of the same name.
- When a primitive value is accessed in read mode, a primitive wrapper object is instantiated so that it can be used to manipulate the data.
- As soon as a statement involving a primitive value is executed, the wrapper object is destroyed.

There are also two built-in objects that exist at the beginning of code execution: `Global` and `Math`. The `Global` object isn't accessible in most ECMAScript implementations; however, web browsers implement it as the `window` object. The `Global` object contains all global variables and functions as properties. The `Math` object contains properties and methods to aid in complex mathematical calculations.

6

Collection Reference Types

WHAT'S IN THIS CHAPTER?

- Working with objects
- Working with arrays and typed arrays
- Working with Map, WeakMap, Set, and WeakSet types

WROX.COM DOWNLOADS FOR THIS CHAPTER

Please note that all the code examples for this chapter are available as a part of this chapter's code download on the book's website at www.wrox.com/go/projavascript4e on the Download Code tab.

THE OBJECT TYPE

Up to this point, most of the reference-value examples have used the `Object` type, which is one of the most commonly used types in ECMAScript. Although instances of `Object` don't have much functionality, they are ideally suited to storing and transmitting data around an application.

There are two ways to explicitly create an instance of `Object`. The first is to use the `new` operator with the `Object` constructor like this:

```
let person = new Object();
person.name = "Nicholas";
person.age = 29;
```

The other way is to use *object literal* notation. Object literal notation is a shorthand form of object definition designed to simplify creating an object with numerous properties. For example, the following defines the same `person` object from the previous example using object literal notation:

```
let person = {
  name: "Nicholas",
  age: 29
};
```

In this example, the left curly brace (`{}`) signifies the beginning of an object literal because it occurs in an *expression context*. An expression context in ECMAScript is a context in which a value (expression) is expected. Assignment operators indicate that a value is expected next, so the left curly brace indicates the beginning of an expression. The same curly brace, when appearing in a *statement context*, such as follows an `if` statement condition, indicates the beginning of a block statement.

Next, the `name` property is specified, followed by a colon, followed by the property's value. A comma is used to separate properties in an object literal, so there's a comma after the string `"Nicholas"` but not after the value `29` because `age` is the last property in the object. Including a comma after the last property causes an error in very old browsers, but all modern ones support it.

Property names can also be specified as strings or numbers when using object literal notation, such as in this example:

```
let person = {
  "name": "Nicholas",
  "age": 29,
  5: true
};
```

This example produces an object with a `name` property, an `age` property, and a property `5`. Note that numeric property names are automatically converted to strings.

It's also possible to create an object with only the default properties and methods using object literal notation by leaving the space between the curly braces empty, such as this:

```
let person = {}; // same as new Object()
person.name = "Nicholas";
person.age = 29;
```

This example is equivalent to the first one in this section, though it looks a little strange. Prefer to use object literal notation only when you're going to specify properties for readability.

NOTE *When defining an object via object literal notation, the `Object` constructor is never actually called.*

Though it's acceptable to use either method of creating `Object` instances, developers tend to favor object literal notation because it requires less code and visually encapsulates all related data. In fact,

object literals have become a preferred way of passing a large number of optional arguments to a function, such as in this example:

```
function displayInfo(args) {
  let output = "";

  if (typeof args.name == "string"){
    output += "Name: " + args.name + "\n";
  }

  if (typeof args.age == "number") {
    output += "Age: " + args.age + "\n";
  }

  alert(output);
}

displayInfo({
  name: "Nicholas",
  age: 29
});

displayInfo({
  name: "Greg"
});
```

Here, the function `displayInfo()` accepts a single argument named `args`. The argument may come in with a property called `name` or `age` or both or neither of those. The function is set up to test for the existence of each property using the `typeof` operator and then to construct a message to display based on availability. This function is then called twice, each time with different data specified in an object literal. The function works correctly in both cases.

NOTE *This pattern for argument passing is best used when there are a large number of optional arguments that can be passed into the function. Generally speaking, named arguments are easier to work with but can get unwieldy when there are numerous optional arguments. The best approach is to use named arguments for those that are required and an object literal to encompass multiple optional arguments.*

Although object properties are typically accessed using *dot notation*, which is common to many object-oriented languages, it's also possible to access properties via *bracket notation*. When you use bracket notation, a string containing the property name is placed between the brackets, as in this example:

```
alert(person["name"]); // "Nicholas"
alert(person.name); // "Nicholas"
```

Functionally, there is no difference between the two approaches. The main advantage of bracket notation is that it allows you to use variables for property access, as in this example:

```
let propertyName = "name";
alert(person[propertyName]); // "Nicholas"
```

You can also use bracket notation when the property name contains characters that would be either a syntax error or a keyword/reserved word. For example:

```
person["first name"] = "Nicholas";
```

Because the name "first name" contains a space, you can't use dot notation to access it. However, property names can contain nonalphanumeric characters—you just need to use bracket notation to access them.

Generally speaking, dot notation is preferred unless variables are necessary to access properties by name.

NOTE *The “Objects, Classes, and Object-Oriented Programming” chapter has extensive coverage on the Object type.*

THE ARRAY TYPE

After the `Object` type, the `Array` type is probably the most used in ECMAScript. An ECMAScript array is very different from arrays in most other programming languages. As in other languages, ECMAScript arrays are ordered lists of data, but unlike in other languages, they can hold any type of data in each slot. This means that it's possible to create an array that has a string in the first position, a number in the second, an object in the third, and so on. ECMAScript arrays are also dynamically sized, automatically growing to accommodate any data that is added to them.

Creating Arrays

Arrays can be created in several basic ways. One is to use the `Array` constructor, as in this line:

```
let colors = new Array();
```

If you know the number of items that will be in the array, you can pass the count into the constructor, and the `length` property will automatically be created with that value. For example, the following creates an array with an initial `length` value of 20:

```
let colors = new Array(20);
```

The `Array` constructor can also be passed items that should be included in the array. The following creates an array with three string values:

```
let colors = new Array("red", "blue", "green");
```

An array can be created with a single value by passing it into the constructor. This gets a little bit tricky because providing a single argument that is a number always creates an array with the given

number of items, whereas an argument of any other type creates a one-item array that contains the specified value. Here's an example:

```
let colors = new Array(3); // create an array with three items
let names = new Array("Greg"); // create an array with one item, the string "Greg"
```

It's possible to omit the `new` operator when using the `Array` constructor. It has the same result, as you can see here:

```
let colors = Array(3); // create an array with three items
let names = Array("Greg"); // create an array with one item, the string "Greg"
```

A second way to create an array is by using *array literal* notation. An array literal is specified by using square brackets and placing a comma-separated list of items between them, as in this example:

```
let colors = ["red", "blue", "green"]; // Creates an array with three strings
let names = []; // Creates an empty array
let values = [1,2,]; // Creates an array with 2 items
```

In this code, the first line creates an array with three string values. The second line creates an empty array by using empty square brackets. The third line shows the effects of leaving a comma after the last value in an array literal: `values` is a two-item array containing the values 1 and 2.

NOTE *As with objects, the `Array` constructor isn't called when an array is created using array literal notation.*

The `Array` constructor also has two additional static methods introduced in ES6 to create arrays: `from()` and `of()`. `from()` is used for converting array-like constructs into an array instance, whereas `of()` is used to convert a collection of arguments into an array instance.

The first argument to `Array.from()` is an “arrayLike” object, which is anything that is iterable or has a property `length` and indexed elements. This type can be used in an abundance of different ways:

```
// Strings will be broken up into an array of single characters
alert(Array.from("Matt")); // ["M", "a", "t", "t"]

// Sets and Maps can be converted into an new array instance using from()
const m = new Map().set(1, 2)
                    .set(3, 4);
const s = new Set().add(1)
                    .add(2)
                    .add(3)
                    .add(4);

alert(Array.from(m)); // [[1, 2], [3, 4]]
alert(Array.from(s)); // [1, 2, 3, 4]

// Array.from() performs a shallow copy of an existing array
const a1 = [1, 2, 3, 4];
const a2 = Array.from(a1);
```

```
alert(a1);           // [1, 2, 3, 4]
alert(a1 === a2);   // false

// Any iterable object can be used
const iter = {
  *[Symbol.iterator]() {
    yield 1;
    yield 2;
    yield 3;
    yield 4;
  }
};
alert(Array.from(iter)); // [1, 2, 3, 4]

// The arguments object can now easily be casted into an array:
function getArgsArray() {
  return Array.from(arguments);
}
alert(getArgsArray(1, 2, 3, 4)); // [1, 2, 3, 4]

// from() will happily use a custom object with required properties
const arrayLikeObject = {
  0: 1,
  1: 2,
  2: 3,
  3: 4,
  length: 4
};
alert(Array.from(arrayLikeObject)); // [1, 2, 3, 4]
```

`Array.from()` also accepts a second optional map function argument. This allows you to augment the new array's values without creating an intermediate array first, which is the case if the same were performed with `Array.from().map()`. A third optional argument specifies the value of `this` inside the map function. The overridden `this` value is not applied inside an arrow function:

```
const a1 = [1, 2, 3, 4];
const a2 = Array.from(a1, x => x**2);
const a3 = Array.from(a1, function(x) {return x**this.exponent}, {exponent: 2});
alert(a2); // [1, 4, 9, 16]
alert(a3); // [1, 4, 9, 16]
```

`Array.of()` will convert the list of arguments into an array. This serves to replace the common pre-ES6 method of converting the `arguments` object into an array using the exceptionally unwieldy `Array.prototype.slice.call(arguments)`:

```
alert(Array.of(1, 2, 3, 4)); // [1, 2, 3, 4]
alert(Array.of(undefined)); // [undefined]
```

Array Holes

Initializing an array with an array literal allows you to create “holes” using sequential commas. ECMAScript will treat the value at the index between the commas as a hole, and the ES6 specification refines how these holes are treated.

An array of holes might be created as follows:

```
const options = [,,,]; // Creates an array with 5 items
alert(options.length); // 5
alert(options); // [,,,]
```

Methods and iterators introduced in ES6 behave differently than methods present in earlier ECMAScript editions. ES6 additions will universally treat the holes as an existing entry with a value of undefined:

```
const options = [,,,5];

for (const option of options) {
  alert(option === undefined);
}
// false
// true
// true
// true
// false

const a = Array.from([,,,]); // Array of 3 holes created with ES6's Array.from()
for (const val of a) {
  alert(val === undefined);
}
// true
// true
// true

alert(Array.of(...[,,,])); // [undefined, undefined, undefined]

for (const [index, value] of options.entries()) {
  alert(value);
}
// 1
// undefined
// undefined
// undefined
// 5
```

Conversely, methods available before ES6 will tend to ignore the holes, although exact behavior can vary slightly between methods:

```
const options = [,,,5];

// map() will skip the holes entirely
alert(options.map(() => 6)); // [6, undefined, undefined, undefined, 6]

// join() treats holes as empty strings
alert(options.join('-')); // "1---5"
```

NOTE *Due to their bizarre behavior and performance issues, avoid using array holes in your code. Prefer to use an explicit `undefined` in place of a hole.*

Indexing into Arrays

To get and set array values, you use square brackets and provide the zero-based numeric index of the value, as shown here:

```
let colors = ["red", "blue", "green"]; // define an array of strings
alert(colors[0]); // display the first item
colors[2] = "black"; // change the third item
colors[3] = "brown"; // add a fourth item
```

The index provided within the square brackets indicates the value being accessed. If the index is less than the number of items in the array, then it will return the value stored in the corresponding item, as `colors[0]` displays "red" in this example. Setting a value works in the same way, replacing the value in the designated position. If a value is set to an index that is past the end of the array, as with `colors[3]` in this example, the array length is automatically expanded to be that index plus 1 (so the length becomes 4 in this example because the index being used is 3).

The number of items in an array is stored in the `length` property, which always returns 0 or more, as shown in the following example:

```
let colors = ["red", "blue", "green"]; // creates an array with three strings
let names = []; // creates an empty array

alert(colors.length); // 3
alert(names.length); // 0
```

A unique characteristic of `length` is that it's not read-only. By setting the `length` property, you can easily remove items from or add items to the end of the array. Consider this example:

```
let colors = ["red", "blue", "green"]; // creates an array with three strings
colors.length = 2;
alert(colors[2]); // undefined
```

Here, the array `colors` starts out with three values. Setting the `length` to 2 removes the last item (in position 2), making it no longer accessible using `colors[2]`. If the `length` were set to a number greater than the number of items in the array, the new items would each get filled with the value of `undefined`, as in this example:

```
let colors = ["red", "blue", "green"]; // creates an array with three strings
colors.length = 4;
alert(colors[3]); // undefined
```

This code sets the `length` of the `colors` array to 4 even though it contains only three items. Position 3 does not exist in the array, so trying to access its value results in the special value `undefined` being returned.

The `length` property can also be helpful in adding items to the end of an array, as in this example:

```
let colors = ["red", "blue", "green"]; // creates an array with three strings
colors[colors.length] = "black";     // add a color (position 3)
colors[colors.length] = "brown";     // add another color (position 4)
```

The last item in an array is always at position `length - 1`, so the next available open slot is at position `length`. Each time an item is added after the last one in the array, the `length` property is automatically updated to reflect the change. That means `colors[colors.length]` assigns a value to position 3 in the second line of this example and to position 4 in the last line. The new length is automatically calculated when an item is placed into a position that's outside of the current array size, which is done by adding 1 to the position, as in this example:

```
let colors = ["red", "blue", "green"]; // creates an array with three strings
colors[99] = "black";                 // add a color (position 99)
alert(colors.length);                 // 100
```

In this code, the `colors` array has a value inserted into position 99, resulting in a new length of 100 ($99 + 1$). Each of the other items, positions 3 through 98, doesn't actually exist and so returns undefined when accessed.

NOTE *Arrays can contain a maximum of 4,294,967,295 items, which should be plenty for almost all programming needs. If you try to add more than that number, an exception occurs. Trying to create an array with an initial size approaching this maximum may cause a long-running script error.*

Detecting Arrays

A classic ECMAScript problem is determining whether a given object is an array. When dealing with a single web page, and therefore a single global scope, the `instanceof` operator works well:

```
if (value instanceof Array){
    // do something on the array
}
```

The one problem with `instanceof` is that it assumes a single global execution context. If you are dealing with multiple frames in a web page, you're really dealing with two distinct global execution contexts and therefore two versions of the `Array` constructor. If you were to pass an array from one frame into a second frame, that array has a different constructor function than an array created natively in the second frame.

To work around this problem, ECMAScript offers the `Array.isArray()` method. The purpose of this method is to definitively determine if a given value is an array regardless of the global execution context in which it was created. Consider the following example:

```
if (Array.isArray(value)){
    // do something on the array
}
```

Iterator Methods

In ES6, three new methods are exposed on the `Array` prototype that allow you to inspect the contents of an array: `keys()`, `values()`, and `entries()`. `keys()` will return an iterator of the array's indices, `values()` will return an iterator of the array's elements, and `entries()` will return an iterator of index/value pairs:

```
const a = ["foo", "bar", "baz", "qux"];

// Because these methods return iterators, you can funnel their contents
// into array instances using Array.from()
const aKeys = Array.from(a.keys());
const aValues = Array.from(a.values());
const aEntries = Array.from(a.entries());

alert(aKeys); // [0, 1, 2, 3]
alert(aValues); // ["foo", "bar", "baz", "qux"]
alert(aEntries); // [[0, "foo"], [1, "bar"], [2, "baz"], [3, "qux"]]
```

ES6 destructuring means it is now very easy to split out the key/value pairs inside a loop:

```
const a = ["foo", "bar", "baz", "qux"];

for (const [idx, element] of a.entries()) {
  alert(idx);
  alert(element);
}
// 0
// foo
// 1
// bar
// 2
// baz
// 3
// qux
```

NOTE *Although they are included as part of the ES6 specification, as of late 2017 some modern browsers have yet to implement some of these methods.*

Copy and Fill Methods

New in ES6 are two methods, `fill()` and `copyWithin()`, that respectively allow for batch fill and copy inside an array. Both methods have a similar function signature in that they allow you to specify a range within an existing array instance using an inclusive start and exclusive end index. Arrays that use this method will never be resized.

The `fill()` method allows you to insert the same value into all or part of an existing array. Specifying the optional start index instructs the fill to begin at that index, and the fill will continue to the end of the array unless an end index is provided. Negative indices are interpreted from the end of the

array; another way to think of this is that negative indices have the array length added to them to calculate a positive index:

```
const zeroes = [0, 0, 0, 0, 0];

// Fill the entire array with 5
zeroes.fill(5);
alert(zeroes); // [5, 5, 5, 5, 5]
zeroes.fill(0); // reset

// Fill all indices >=3 with 6
zeroes.fill(6, 3);
alert(zeroes); // [0, 0, 0, 6, 6]
zeroes.fill(0); // reset

// Fill all indices >= 1 and < 3 with 7
zeroes.fill(7, 1, 3);
alert(zeroes); // [0, 7, 7, 0, 0];
zeroes.fill(0); // reset

// Fill all indices >=1 and < 4 with 8
// (-4 + zeroes.length = 1)
// (-1 + zeroes.length = 4)
zeroes.fill(8, -4, -1);
alert(zeroes); // [0, 8, 8, 8, 0];
```

`fill()` silently ignores ranges that exceed the boundaries of the array, are zero length, or go backwards:

```
const zeroes = [0, 0, 0, 0, 0];

// Fill with too low indices is noop
zeroes.fill(1, -10, -6);
alert(zeroes); // [0, 0, 0, 0, 0]

// Fill with too high indices is noop
zeroes.fill(1, 10, 15);
alert(zeroes); // [0, 0, 0, 0, 0]

// Fill with reversed indices is noop
zeroes.fill(2, 4, 2);
alert(zeroes); // [0, 0, 0, 0, 0]

// Fill with partial index overlap is best effort
zeroes.fill(4, 3, 10)
alert(zeroes); // [0, 0, 0, 4, 4]
```

Unlike `fill()`, `copyWithin()` instead performs an iterative shallow copy of some of the array and overwrites existing values beginning at the provided index. However, it uses the same conventions with respect to start and end indices:

```
let ints,
    reset = () => ints = [0, 1, 2, 3, 4, 5, 6, 7, 8, 9];
reset();
```

```
// Copy the contents of ints beginning at index 0 to the values beginning at index 5.
// Stops when it reaches the end of the array either in the source
// indices or the destination indices.
ints.copyWithWithin(5);
alert(ints); // [0, 1, 2, 3, 4, 0, 1, 2, 3, 4]
reset();

// Copy the contents of ints beginning at index 5 to the values beginning at index 0.
ints.copyWithWithin(0, 5);
alert(ints); // [5, 6, 7, 8, 9, 5, 6, 7, 8, 9]
reset();

// Copy the contents of ints beginning at index 0 and ending at index 3 to values
// beginning at index 4.
ints.copyWithWithin(4, 0, 3);
alert(ints); // [0, 1, 2, 3, 0, 1, 2, 7, 8, 9]
reset();

// The JS engine will perform a full copy of the range of values before inserting,
// so there is no danger of overwrite during the copy.
ints.copyWithWithin(2, 0, 6);
alert(ints); // [0, 1, 0, 1, 2, 3, 4, 5, 8, 9]
reset();

// Support for negative indexing behaves identically to fill() in that negative
// indices are calculated relative to the end of the array
ints.copyWithWithin(-4, -7, -3);
alert(ints); // [0, 1, 2, 3, 4, 5, 3, 4, 5, 6]
```

`fill()` silently ignores ranges that exceed the boundaries of the array, are zero length, or go backwards:

```
let ints,
    reset = () => ints = [0, 1, 2, 3, 4, 5, 6, 7, 8, 9];
reset();

// Copy with too low indices is noop
ints.copyWithWithin(1, -15, -12);
alert(ints); // [0, 1, 2, 3, 4, 5, 6, 7, 8, 9];
reset();

// Copy with too high indices is noop
ints.copyWithWithin(1, 12, 15);
alert(ints); // [0, 1, 2, 3, 4, 5, 6, 7, 8, 9];
reset();

// Copy with reversed indices is noop
ints.copyWithWithin(2, 4, 2);
alert(ints); // [0, 1, 2, 3, 4, 5, 6, 7, 8, 9];
reset();

// Copy with partial index overlap is best effort
ints.copyWithWithin(4, 7, 10)
alert(ints); // [0, 1, 2, 3, 7, 8, 9, 7, 8, 9];
```

Conversion Methods

As mentioned previously, all objects have `toLocaleString()`, `toString()`, and `valueOf()` methods. The `toString()` and `valueOf()` methods return the same value when called on an array. The result is a comma-separated string that contains the string equivalents of each value in the array, which is to say that each item has its `toString()` method called to create the final string. Take a look at this example:

```
let colors = ["red", "blue", "green"]; // creates an array with three strings
alert(colors.toString()); // red,blue,green
alert(colors.valueOf()); // red,blue,green
alert(colors); // red,blue,green
```

In this code, the `toString()` and `valueOf()` methods are first called explicitly to return the string representation of the array, which combines the strings, separating them by commas. The last line passes the array directly into `alert()`. Because `alert()` expects a string, it calls `toString()` behind the scenes to get the same result as when `toString()` is called directly.

The `toLocaleString()` method may end up returning the same value as `toString()` and `valueOf()`, but not always. When `toLocaleString()` is called on an array, it creates a comma-delimited string of the array values. The only difference between this and the two other methods is that `toLocaleString()` calls each item's `toLocaleString()` instead of `toString()` to get its string value. Consider the following example:

```
let person1 = {
  toLocaleString() {
    return "Nikolaos";
  },

  toString() {
    return "Nicholas";
  }
};

let person2 = {
  toLocaleString() {
    return "Grigorios";
  },

  toString() {
    return "Greg";
  }
};

let people = [person1, person2];
alert(people); // Nicholas,Greg
alert(people.toString()); // Nicholas,Greg
alert(people.toLocaleString()); // Nikolaos,Grigorios
```

Here, two objects are defined, `person1` and `person2`. Each object defines both a `toString()` method and a `toLocaleString()` method that return different values. An array, `people`, is created to contain both objects. When passed into `alert()`, the output is "Nicholas,Greg" because the `toString()` method is called on each item in the array (the same as when `toString()` is called explicitly on the

next line). When `toLocaleString()` is called on the array, the result is "Nikolaos,Grigorios" because this calls `toLocaleString()` on each array item.

The inherited methods `toLocaleString()`, `toString()`, and `valueOf()` each return the array items as a comma-separated string. It's possible to construct a string with a different separator using the `join()` method. The `join()` method accepts one argument, which is the string separator to use, and returns a string containing all items. Consider this example:

```
let colors = ["red", "green", "blue"];
alert(colors.join(",")); // red,green,blue
alert(colors.join("||")); // red||green||blue
```

Here, the `join()` method is used on the `colors` array to duplicate the output of `toString()`. By passing in a comma, the result is a comma-separated list of values. On the last line, double pipes are passed in, resulting in the string "red||green||blue". If no value or `undefined` is passed into the `join()` method, then a comma is used as the separator.

NOTE *If an item in the array is null or undefined, it is represented by an empty string in the result of `join()`, `toLocaleString()`, `toString()`, and `valueOf()`.*

Stack Methods

One of the interesting things about ECMAScript arrays is that they provide a method to make an array behave like other data structures. An array object can act just like a stack, which is one of a group of data structures that restrict the insertion and removal of items. A stack is referred to as a *last-in-first-out* (LIFO) structure, meaning that the most recently added item is the first one removed. The insertion (called a *push*) and removal (called a *pop*) of items in a stack occur at only one point: the top of the stack. ECMAScript arrays provide `push()` and `pop()` specifically to allow stack-like behavior.

The `push()` method accepts any number of arguments and adds them to the end of the array, returning the array's new length. The `pop()` method, on the other hand, removes the last item in the array, decrements the array's length, and returns that item. Consider this example:

```
let colors = new Array(); // create an array
let count = colors.push("red", "green"); // push two items
alert(count); // 2

count = colors.push("black"); // push another item on
alert(count); // 3

let item = colors.pop(); // get the last item
alert(item); // "black"
alert(colors.length); // 2
```

In this code, an array is created for use as a stack (note that there's no special code required to make this work; `push()` and `pop()` are default methods on arrays). First, two strings are pushed onto the end of the array using `push()`, and the result is stored in the variable `count` (which gets the value of 2).

Then, another value is pushed on, and the result is once again stored in `count`. Because there are now three items in the array, `push()` returns 3. When `pop()` is called, it returns the last item in the array, which is the string `"black"`. The array then has only two items left.

The stack methods may be used in combination with all of the other array methods as well, as in this example:

```
let colors = ["red", "blue"];
colors.push("brown");           // add another item
colors[3] = "black";           // add an item
alert(colors.length);          // 4

let item = colors.pop();        // get the last item
alert(item);                    // "black"
```

Here, an array is initialized with two values. A third value is added via `push()`, and a fourth is added by direct assignment into position 3. When `pop()` is called, it returns the string `"black"`, which was the last value added to the array.

Queue Methods

Just as stacks restrict access in a LIFO data structure, queues restrict access in a *first-in-first-out* (FIFO) data structure. A queue adds items to the end of a list and retrieves items from the front of the list. Because the `push()` method adds items to the end of an array, all that is needed to emulate a queue is a method to retrieve the first item in the array. The array method for this is called `shift()`, which removes the first item in the array and returns it, decrementing the length of the array by one. Using `shift()` in combination with `push()` allows arrays to be used as queues:

```
let colors = new Array();           // create an array
let count = colors.push("red", "green"); // push two items
alert(count);                       // 2

count = colors.push("black");        // push another item on
alert(count);                        // 3

let item = colors.shift();           // get the first item
alert(item);                          // "red"
alert(colors.length);                // 2
```

This example creates an array of three colors using the `push()` method. The highlighted line shows the `shift()` method being used to retrieve the first item in the array, which is `"red"`. With that item removed, `"green"` is moved into the first position and `"black"` is moved into the second, leaving the array with two items.

ECMAScript also provides an `unshift()` method for arrays. As the name indicates, `unshift()` does the opposite of `shift()`: it adds any number of items to the front of an array and returns the new array length. By using `unshift()` in combination with `pop()`, it's possible to emulate a queue in the opposite direction, where new values are added to the front of the array and values are retrieved off the back, as in this example:

```
let colors = new Array();           // create an array
let count = colors.unshift("red", "green"); // push two items
```

```
alert(count); // 2

count = colors.unshift("black"); // push another item on
alert(count); // 3

let item = colors.pop(); // get the first item
alert(item); // "green"
alert(colors.length); // 2
```

In this code, an array is created and then populated by using `unshift()`. First "red" and "green" are added to the array, and then "black" is added, resulting in an order of "black", "red", "green". When `pop()` is called, it removes the last item, "green", and returns it.

Reordering Methods

Two methods deal directly with the reordering of items already in the array: `reverse()` and `sort()`. As one might expect, the `reverse()` method simply reverses the order of items in an array. Consider the following example:

```
let values = [1, 2, 3, 4, 5];
values.reverse();
alert(values); // 5,4,3,2,1
```

Here, the array's values are initially set to 1, 2, 3, 4, and 5, in that order. Calling `reverse()` on the array reverses the order to 5, 4, 3, 2, 1. This method is fairly straightforward but doesn't provide much flexibility, which is where the `sort()` method comes in.

By default, the `sort()` method puts the items in ascending order—with the smallest value first and the largest value last. To do this, the `sort()` method calls the `String()` casting function on every item and then compares the strings to determine the correct order. This occurs even if all items in an array are numbers, as in this example:

```
let values = [0, 1, 5, 10, 15];
values.sort();
alert(values); // 0,1,10,15,5
```

Even though the values in this example begin in correct numeric order, the `sort()` method changes that order based on their string equivalents. So even though 5 is less than 10, the string "10" comes before "5" when doing a string comparison, so the array is updated accordingly. Clearly, this is not an optimal solution in many cases, so the `sort()` method allows you to pass in a *comparison function* that indicates which value should come before which.

A comparison function accepts two arguments and returns a negative number if the first argument should come before the second, a zero if the arguments are equal, or a positive number if the first argument should come after the second. Here's an example of a simple comparison function:

```
function compare(value1, value2) {
  if (value1 < value2) {
    return -1;
  } else if (value1 > value2) {
    return 1;
  }
}
```

```

    } else {
      return 0;
    }
  }
}

```

This comparison function works for most data types and can be used by passing it as an argument to the `sort()` method, as in the following example:

```

let values = [0, 1, 5, 10, 15];
values.sort(compare);
alert(values); // 0,1,5,10,15

```

When the comparison function is passed to the `sort()` method, the numbers remain in the correct order. Of course, the comparison function could produce results in descending order if you simply switch the return values like this:

```

function compare(value1, value2) {
  if (value1 < value2) {
    return 1;
  } else if (value1 > value2) {
    return -1;
  } else {
    return 0;
  }
}

```

```

let values = [0, 1, 5, 10, 15];
values.sort(compare);
alert(values); // 15,10,5,1,0

```

Alternately, the `compare` function can be shortened and defined as an inline arrow function:

```

let values = [0, 1, 5, 10, 15];
values.sort((a, b) => a < b ? a > b ? -1 : 0);
alert(values); // 15,10,5,1,0

```

In this modified example, the comparison function returns 1 if the first value should come after the second and `-1` if the first value should come before the second. Swapping these means the larger value will come first and the array will be sorted in descending order. Of course, if you just want to reverse the order of the items in the array, `reverse()` is a much faster alternative than sorting.

NOTE Both `reverse()` and `sort()` return a reference to the array on which they were applied.

A much simpler version of the comparison function can be used with numeric types and objects whose `valueOf()` method returns numeric values (such as the `Date` object). In either case, you can simply subtract the second value from the first as shown here:

```

function compare(value1, value2){
  return value2 - value1;
}

```

Because comparison functions work by returning a number less than zero, zero, or a number greater than zero, the subtraction operation handles all of the cases appropriately.

Manipulation Methods

There are various ways to work with the items already contained in an array. The `concat()` method, for instance, allows you to create a new array based on all of the items in the current array. This method begins by creating a copy of the array and then appending the method arguments to the end and returning the newly constructed array. When no arguments are passed in, `concat()` simply clones the array and returns it. If one or more arrays are passed in, `concat()` appends each item in these arrays to the end of the result. If the values are not arrays, they are simply appended to the end of the resulting array. Consider this example:

```
let colors = ["red", "green", "blue"];
let colors2 = colors.concat("yellow", ["black", "brown"]);

alert(colors); // ["red", "green", "blue"]
alert(colors2); // ["red", "green", "blue", "yellow", "black", "brown"]
```

This code begins with the `colors` array containing three values. The `concat()` method is called on `colors`, passing in the string `"yellow"` and an array containing `"black"` and `"brown"`. The result, stored in `colors2`, contains `"red"`, `"green"`, `"blue"`, `"yellow"`, `"black"`, and `"brown"`. The original array, `colors`, remains unchanged.

You can override this force-flattening default behavior by specifying a special symbol on the argument array instance, `Symbol.isConcatSpreadable`. This will prevent the `concat()` method from flattening the result. Conversely, setting the value to `true` will force array-like objects to be flattened:

```
let colors = ["red", "green", "blue"];
let newColors = ["black", "brown"];
let moreNewColors = {
  [Symbol.isConcatSpreadable]: true,
  length: 2,
  0: "pink",
  1: "cyan"
};

newColors[Symbol.isConcatSpreadable] = false;

// Force the array to not be flattened
let colors2 = colors.concat("yellow", newColors);

// Force the array-like object to be flattened
let colors3 = colors.concat(moreNewColors);

alert(colors); // ["red", "green", "blue"]
alert(colors2); // ["red", "green", "blue", "yellow", ["black", "brown"]]
alert(colors3); // ["red", "green", "blue", "pink", "cyan"]
```

The next method, `slice()`, creates an array that contains one or more items already contained in an array. The `slice()` method may accept one or two arguments: the starting and stopping positions of

the items to return. If only one argument is present, the method returns all items between that position and the end of the array. If there are two arguments, the method returns all items between the start position and the end position, not including the item in the end position. Keep in mind that this operation does not affect the original array in any way. Consider the following:

```
let colors = ["red", "green", "blue", "yellow", "purple"];
let colors2 = colors.slice(1);
let colors3 = colors.slice(1, 4);

alert(colors2); // green,blue,yellow,purple
alert(colors3); // green,blue,yellow
```

In this example, the `colors` array starts out with five items. Calling `slice()` and passing in 1 yields an array with four items, omitting "red" because the operation began copying from position 1, which contains "green". The resulting `colors2` array contains "green", "blue", "yellow", and "purple". The `colors3` array is constructed by calling `slice()` and passing in 1 and 4, meaning that the method will begin copying from the item in position 1 and stop copying at the item in position 3. As a result, `colors3` contains "green", "blue", and "yellow".

NOTE *If either the start or end position of `slice()` is a negative number, then the number is subtracted from the length of the array to determine the appropriate locations. For example, calling `slice(-2, -1)` on an array with five items is the same as calling `slice(3, 4)`. If the end position is smaller than the start, then an empty array is returned.*

Perhaps the most powerful array method is `splice()`, which can be used in a variety of ways. The main purpose of `splice()` is to insert items into the middle of an array, but there are three distinct ways of using this method. They are as follows:

- **Deletion**—Any number of items can be deleted from the array by specifying just two arguments: the position of the first item to delete and the number of items to delete. For example, `splice(0, 2)` deletes the first two items.
- **Insertion**—Items can be inserted into a specific position by providing three or more arguments: the starting position, 0 (the number of items to delete), and the item to insert. Optionally, you can specify a fourth parameter, fifth parameter, or any number of other parameters to insert. For example, `splice(2, 0, "red", "green")` inserts the strings "red" and "green" into the array at position 2.
- **Replacement**—Items can be inserted into a specific position while simultaneously deleting items, if you specify three arguments: the starting position, the number of items to delete, and any number of items to insert. The number of items to insert doesn't have to match the number of items to delete. For example, `splice(2, 1, "red", "green")` deletes one item at position 2 and then inserts the strings "red" and "green" into the array at position 2.

The `splice()` method always returns an array that contains any items that were removed from the array (or an empty array if no items were removed). These three uses are illustrated in the following code:

```
let colors = ["red", "green", "blue"];
let removed = colors.splice(0,1); // remove the first item
alert(colors);                  // green,blue
alert(removed);                 // red - one item array

removed = colors.splice(1, 0, "yellow", "orange"); // insert two items at position 1
alert(colors);                  // green,yellow,orange,blue
alert(removed);                 // empty array

removed = colors.splice(1, 1, "red", "purple"); // insert two values, remove one
alert(colors);                  // green,red,purple,orange,blue
alert(removed);                 // yellow - one item array
```

This example begins with the `colors` array containing three items. When `splice` is called the first time, it simply removes the first item, leaving `colors` with the items "green" and "blue". The second time `splice()` is called, it inserts two items at position 1, resulting in `colors` containing "green", "yellow", "orange", and "blue". No items are removed at this point, so an empty array is returned. The last time `splice()` is called, it removes one item, beginning in position 1, and inserts "red" and "purple". After all of this code has been executed, the `colors` array contains "green", "red", "purple", "orange", and "blue".

Search and Location Methods

ECMAScript offers two strategies for searching inside an array instance: searching by strict equivalence, and searching with a predicate function.

Strict Equivalence

ECMAScript's three strict equivalence lookup methods are `indexOf()` and `lastIndexOf()`, available in all ECMAScript versions, and `includes()`, which was introduced in the ECMAScript 7 specification. Each of these methods accepts two arguments: the item to look for and an optional index from which to start looking. The `indexOf()` and `includes()` methods start searching from the front of the array (item 0) and continue to the back, whereas `lastIndexOf()` starts from the last item in the array and continues to the front.

`indexOf()` and `lastIndexOf()` each return the position of the item in the array or `-1` if the item isn't in the array. `includes()` returns a Boolean indicating if at least one element in the searched array matched the provided element. An identity comparison is used when comparing the first argument to each item in the array, meaning that the items must be strictly equal as if compared using `===`. Here are some examples of this usage:

```
let numbers = [1, 2, 3, 4, 5, 4, 3, 2, 1];

alert(numbers.indexOf(4));      // 3
alert(numbers.lastIndexOf(4)); // 5
alert(numbers.includes(4));     // true
```



```

alert(numbers.indexOf(4, 4)); // 5
alert(numbers.lastIndexOf(4, 4)); // 3
alert(numbers.includes(4, 7)); // false

let person = { name: "Nicholas" };
let people = [{ name: "Nicholas" }];
let morePeople = [person];

alert(people.indexOf(person)); // -1
alert(morePeople.indexOf(person)); // 0
alert(people.includes(person)); // false
alert(morePeople.includes(person)); // true

```

Predicate Search

ECMAScript also allows you to define a predicate function that will be invoked at each index. The return value of the function determines if the element at that index is considered a match.

A predicate function takes the form `predicate(element, index, array)`, where `element` is the current element in the array being examined, `index` is the index of `element` inside the array, and `array` is the array instance. A truthy return value indicates a match.

The two methods that make use of this are `find()` and `findIndex()`. Both begin searching at the lowest index in the array; `find()` returns the first matching element, and `findIndex()` returns the index of the first matching element. Both methods also accept a second optional argument that allows you to specify the value of `this` inside the predicate.

```

const people = [
  {
    name: "Matt",
    age: 27
  },
  {
    name: "Nicholas",
    age: 29
  }
];

alert(people.find((element, index, array) => element.age < 28));
// {name: "Matt", age: 27}

alert(people.findIndex((element, index, array) => element.age < 28));
// 0

```

Neither method will continue searching once a match has been found.

```

const evens = [2, 4, 6];

// Last element of array will never be inspected after match is found
evens.find((element, index, array) => {
  alert(element);
  alert(index);
  alert(array);
  return element === 4;
});

```

```
// 2
// 0
// [2, 4, 6]
// 4
// 1
// [2, 4, 6]
```

Iterative Methods

ECMAScript defines five iterative methods for arrays. Each of the methods accepts two arguments: a function to run on each item and an optional scope object in which to run the function (affecting the value of `this`). The function passed into one of these methods will receive three arguments: the array item value, the position of the item in the array, and the array object itself. Depending on the method, the results of this function's execution may or may not affect the method's return value. The iterative methods are as follows:

- `every()`—Runs the given function on every item in the array and returns `true` if the function returns `true` for every item.
- `filter()`—Runs the given function on every item in the array and returns an array of all items for which the function returns `true`.
- `forEach()`—Runs the given function on every item in the array. This method has no return value.
- `map()`—Runs the given function on every item in the array and returns the result of each function call in an array.
- `some()`—Runs the given function on every item in the array and returns `true` if the function returns `true` for any one item.

These methods do not change the values contained in the array.

Of these methods, the two most similar are `every()` and `some()`, which both query the array for items matching some criteria. For `every()`, the passed-in function must return `true` for every item in order for the method to return `true`; otherwise, it returns `false`. The `some()` method, on the other hand, returns `true` if even one of the items causes the passed-in function to return `true`. Here is an example:

```
let numbers = [1, 2, 3, 4, 5, 4, 3, 2, 1];

let everyResult = numbers.every((item, index, array) => item > 2);
alert(everyResult); // false

let someResult = numbers.some((item, index, array) => item > 2);
alert(someResult); // true
```

This code calls both `every()` and `some()` with a function that returns `true` if the given item is greater than 2. For `every()`, the result is `false` because only some of the items fit the criteria. For `some()`, the result is `true` because at least one of the items is greater than 2.

The next method is `filter()`, which uses the given function to determine if an item should be included in the array that it returns. For example, to return an array of all numbers greater than 2, the following code can be used:

```
let numbers = [1, 2, 3, 4, 5, 4, 3, 2, 1];

let filterResult = numbers.filter((item, index, array) => item > 2);
alert(filterResult); // [3,4,5,4,3]
```

Here, an array containing the values 3, 4, 5, 4, and 3 is created and returned by the call to `filter()` because the passed-in function returns `true` for each of those items. This method is very helpful when querying an array for all items matching some criteria.

The `map()` method also returns an array. Each item in the array is the result of running the passed-in function on the original array item in the same location. For example, you can multiply every number in an array by two and are returned an array of those numbers, as shown here:

```
let numbers = [1, 2, 3, 4, 5, 4, 3, 2, 1];

let mapResult = numbers.map((item, index, array)=> item * 2);

alert(mapResult); // [2,4,6,8,10,8,6,4,2]
```

The code in this example returns an array containing the result of multiplying each number by two. This method is helpful when creating arrays whose items correspond to one another.

The last method is `forEach()`, which simply runs the given function on every item in an array. There is no return value and it is essentially the same as iterating over an array using a `for` loop. Here's an example:

```
let numbers = [1, 2, 3, 4, 5, 4, 3, 2, 1];

numbers.forEach((item, index, array) => {
  // do something here
});
```

All of these array methods ease the processing of arrays by performing a number of different operations.

Reduction Methods

ECMAScript offers two reduction methods for arrays: `reduce()` and `reduceRight()`. Both methods iterate over all items in the array and build up a value that is ultimately returned. The `reduce()` method does this starting at the first item and traveling toward the last, whereas `reduceRight()` starts at the last and travels toward the first.

Both methods accept two arguments: a function to call on each item and an optional initial value upon which the reduction is based. The function passed into `reduce()` or `reduceRight()` accepts four arguments: the previous value, the current value, the item's index, and the array object. Any value returned from the function is automatically passed in as the first argument for the next item. The first iteration occurs on the second item in the array, so the first argument is the first item in the array and the second argument is the second item in the array.

You can use the `reduce()` method to perform operations such as adding all numbers in an array. Here's an example:

```
let values = [1, 2, 3, 4, 5];
let sum = values.reduce((prev, cur, index, array) => prev + cur);

alert(sum); // 15
```

The first time the callback function is executed, `prev` is 1 and `cur` is 2. The second time, `prev` is 3 (the result of adding 1 and 2), and `cur` is 3 (the third item in the array). This sequence continues until all items have been visited and the result is returned.

The `reduceRight()` method works in the same way, just in the opposite direction. Consider the following example:

```
let values = [1, 2, 3, 4, 5];
let sum = values.reduceRight(function(prev, cur, index, array){
  return prev + cur;
});
alert(sum); // 15
```

In this version of the code, `prev` is 5 and `cur` is 4 the first time the callback function is executed. The result is the same, of course, because the operation is simple addition.

The decision to use `reduce()` or `reduceRight()` depends solely on the direction in which the items in the array should be visited. They are exactly equal in every other way.

TYPED ARRAYS

New in ECMAScript 6, the typed array is a construct designed for efficiently passing binary data to native libraries. There is no actual “TypedArray” type in JavaScript—rather, the term refers to a collection of specialized arrays that contain numeric types. To understand how to use the typed array, it is helpful to first understand its intended purpose.

History

As web browsers gained adoption, it was not difficult to foresee that the ability to run complex 3D applications inside of them would be in demand. As early as 2006, browser vendors including Mozilla and Opera began to experiment with a programming platform for rendering graphics-intensive applications inside the browser without requiring any plugins. The goal was to develop a JavaScript API that could make use of a 3D graphics API and GPU acceleration to enable rendering of complex graphics on a `<canvas>` element.

WebGL

The eventual JavaScript API was based on the OpenGL for Embedded Systems (OpenGL ES) 2.0 specification, a subset of OpenGL that specializes in 2D and 3D computer graphics. The new API, named the Web Graphics Library (WebGL), saw its 1.0 release in March 2011. With it, developers were able to write graphics-intensive application code that could natively be interpreted by any WebGL-compliant web browser.

In initial versions of WebGL, a fundamental mismatch between JavaScript arrays and native arrays caused performance issues. The graphics driver APIs often did not want numbers passed to them in JavaScript's default double floating point format. Furthermore, the graphics driver APIs expected arrays of numbers to be passed to them in a binary format, which of course is nothing like the JavaScript array's format in memory. Therefore, each time an array was passed between WebGL and the JavaScript runtime, the WebGL binding would perform the expensive operation of allocating a new array in the destination environment, iterating over the array in its current format, and casting the number into an appropriate format in the new array.

Emergence of Typed Arrays

This, of course, was untenable, and Mozilla solved this problem by implementing `CanvasFloatArray`, a C-style array of floating point numbers that offered a JavaScript interface. Using this type allowed the JavaScript runtime to allocate, read, and write an array that could be passed directly to and from the graphics driver API. The `CanvasFloatArray` would eventually be reshaped into the `Float32Array`, which was the first “type” available for typed arrays as they currently exist.

Using ArrayBuffers

`Float32Array` is actually one type of “view” that allows the JavaScript runtime to access a block of allocated memory called an `ArrayBuffer`. The `ArrayBuffer` is the fundamental unit referred to by all typed arrays and views.

NOTE *The `TypedArrayBuffer` is a variant of the `ArrayBuffer` that can be passed between execution contexts without performing a copy. Refer to the “Workers” chapter for coverage of this type.*

`ArrayBuffer` is a normal JavaScript constructor that can be used to allocate a specific number of bytes in memory.

```
const buf = new ArrayBuffer(16); // Allocates 16 bytes of memory
alert(buf.byteLength);         // 16
```

An `ArrayBuffer` can never be resized once it is created. However, you are able to copy all or part of an existing `ArrayBuffer` into a new instance using `slice()`:

```
const buf1 = new ArrayBuffer(16);
const buf2 = buf1.slice(4, 12);
alert(buf2.byteLength); // 8
```

`ArrayBuffer` is in some ways similar to the C++ `malloc()`, with several notable exceptions:

- When `malloc()` fails to allocate, it returns a null pointer. If `ArrayBuffer` allocation fails, it throws an error.
- A `malloc()` call can take advantage of virtual memory, so the maximum size of the allocation is only bounded by the addressable system memory. `ArrayBuffer` allocation cannot exceed `Number.MAX_SAFE_INTEGER` (2^{53}) bytes.

- A successful `malloc()` invocation performs no initialization of the actual addresses. Declaring an `ArrayBuffer` initializes all the bits to 0s.
- Heap memory allocated by `malloc()` cannot be used by the system until `free()` is invoked or the program exits. Heap memory allocated by declaring an `ArrayBuffer` is still garbage collected—no manual memory management is required.

The contents of an `ArrayBuffer` cannot be read or written with only a reference to the buffer instance. To read or write data inside, you must do so with a view. There are different types of views, but they all refer to binary data stored in an `ArrayBuffer`.

DataViews

The first type of view that allows you to read and write an `ArrayBuffer` is the `DataView`. This view is designed for file I/O and network I/O; the API allows for a high degree of control when manipulating buffer data, but it offers reduced performance compared to different view types as a result. A `DataView` does not assume anything about the buffer contents and is not iterable.

A `DataView` must be created to read from and write to an `ArrayBuffer` that already exists. It can use the whole buffer or only part of it, and it maintains a reference to the buffer instance and where in the buffer the view begins.

```
const buf = new ArrayBuffer(16);

// DataView default to use the entire ArrayBuffer
const fullDataView = new DataView(buf);
alert(fullDataView.byteOffset); // 0
alert(fullDataView.byteLength); // 16
alert(fullDataView.buffer === buf); // true

// Constructor takes an optional byte offset and byte length
// byteOffset=0 begins the view at the start of the buffer
// byteLength=8 restricts the view to the first 8 bytes
const firstHalfDataView = new DataView(buf, 0, 8);
alert(firstHalfDataView.byteOffset); // 0
alert(firstHalfDataView.byteLength); // 8
alert(firstHalfDataView.buffer === buf); // true

// DataView will use the remainder of the buffer unless specified
// byteOffset=8 begins the view at the 9th byte of the buffer
// byteLength default is the remainder of the buffer
const secondHalfDataView = new DataView(buf, 8);
alert(secondHalfDataView.byteOffset); // 8
alert(secondHalfDataView.byteLength); // 8
alert(secondHalfDataView.buffer === buf); // true
```

To read from and write to the buffer through a `DataView`, you will require the use of several components:

- The byte offset at which you wish to read or write. This can be thought of as a sort of “address” within the `DataView`.

- The `ElementType` the `DataView` should use for conversion between the `Number` type in the JavaScript runtime and the binary format in the buffer.
- The endianness of the value in memory. Defaults to big-endian.

ElementType

The `DataView` makes no assumptions about what data type is stored inside the buffer. The API it exposes forces you to specify an `ElementType` when reading or writing, and the `DataView` will dutifully perform the conversion to execute that read or write.

ECMAScript 6 supports eight different `ElementTypes`:

ELEMENTTYPE	BYTES	DESCRIPTION	C EQUIVALENT	RANGE OF VALUES
Int8	1	8-bit signed integer	signed char	-128 to 127
Uint8	1	8-bit unsigned integer	unsigned char	0 to 255
Int16	2	16-bit signed integer	short	-32768 to 32767
Uint16	2	16-bit unsigned integer	unsigned short	0 to 65535
Int32	4	32-bit signed integer	int	-2,147,483,648 to 2,147,483,647
Uint32	4	32-bit unsigned integer	unsigned int	0 to 4,294,967,295
Float32	4	32-bit IEEE-754 floating point	float	-3.4E+38 to +3.4E+38
Float64	8	64-bit IEEE-754 floating point	double	-1.7E+308 to +1.7E+308

The `DataView` exposes `get` and `set` methods for each of these types, which use a `byteOffset` to address into the buffer for reading and writing values. Types can be used interchangeably, as demonstrated here:

```
// Allocate two bytes of memory and declare a DataView
const buf = new ArrayBuffer(2);
const view = new DataView(buf);

// Demonstrate that the entire buffer is indeed all zeroes
// Check the first and second byte
alert(view.getInt8(0)); // 0
alert(view.getInt8(1)); // 0
// Check the entire buffer
alert(view.getInt16(0)); // 0

// Set the entire buffer to ones
// 255 in binary is 11111111 (2^8 - 1)
view.setUint8(0, 255);
```

```
// DataView will automatically cast values to the designated ElementType
// 255 in hex is 0xFF
view.setUint8(1, 0xFF);

// The buffer is now all ones, which when read as a
// two's complement signed integer should be -1
alert(view.getInt16(0)); // -1
```

Big-Endian and Little-Endian

The buffer's bytes in the previous example were intentionally identical to avoid the issue of endianness. “Endianness” refers to the convention of byte ordering maintained by a computing system. For the purposes of `DataViews`, there are only two conventions supported: big-endian and little-endian. Big-endian, also referred to as “network byte order,” means that the most significant byte is held in the first byte, and the least significant byte is held in the last byte. Little-endian means the least significant byte is held in the first byte, and the most significant byte is held in the last byte.

The native endianness of the system executing the JavaScript runtime will determine how it reads and writes bytes, but a `DataView` does not obey this convention. A `DataView` is an unbiased interface to a segment of memory and will follow whatever endianness you specify. All `DataView` API methods default to the big-endian convention but accept an optional final Boolean argument that allows you to enable the little-endian convention by setting it to true.

```
// Allocate two bytes of memory and declare a DataView
const buf = new ArrayBuffer(2);
const view = new DataView(buf);

// Fill the buffer so that the first bit and last bit are 1
view.setUint8(0, 0x80); // Sets leftmost bit to 1
view.setUint8(1, 0x01); // Sets rightmost bit to 1

// Buffer contents (spaced for readability):
// 0x8 0x0 0x0 0x1
// 1000 0000 0000 0001

// Read a big-endian Uint16
// 0x80 is the high byte, 0x01 is the low byte
// 0x8001 = 215 + 20 = 32768 + 1 = 32769
alert(view.getUint16(0)); // 32769

// Read a little-endian Uint16
// 0x01 is the high byte, 0x80 is the low byte
// 0x0180 = 28 + 27 = 256 + 128 = 384
alert(view.getUint16(0, true)); // 384

// Write a big-endian Uint16
view.setUint16(0, 0x0004);

// Buffer contents (spaced for readability):
// 0x0 0x0 0x0 0x4
// 0000 0000 0000 0100
```



```

alert(view.getUint8(0)); // 0
alert(view.getUint8(1)); // 4

// Write a little-endian Uint16
view.setUint16(0, 0x0002, true);

// Buffer contents (spaced for readability):
// 0x0 0x2 0x0 0x0
// 0000 0010 0000 0000

alert(view.getUint8(0)); // 2
alert(view.getUint8(1)); // 0

```

Corner Cases

A `DataView` will only complete a read or write if there is sufficient buffer space to do so; otherwise it throws a `RangeError`:

```

const buf = new ArrayBuffer(6);
const view = new DataView(buf);

// Attempt to get a value that partially extends past end of buffer
view.getInt32(4);
// RangeError

// Attempt to get a value past the end of the buffer
view.getInt32(8);
// RangeError

// Attempt to get a value past the end of the buffer
view.getInt32(-1);
// RangeError

// Attempt to set a value that extends past end of buffer
view.setInt32(4, 123);
// RangeError

```

A `DataView` will make a best effort to cast a value into the appropriate type when writing to a buffer, falling back to 0. If it cannot, it will throw an error:

```

const buf = new ArrayBuffer(1);
const view = new DataView(buf);

view.setInt8(0, 1.5);
alert(view.getInt8(0)); // 1

view.setInt8(0, [4]);
alert(view.getInt8(0)); // 4

view.setInt8(0, 'f');
alert(view.getInt8(0)); // 0

view.setInt8(0, Symbol());
// TypeError

```

Typed Arrays

Typed arrays are another form of an `ArrayBuffer` view. Though it is similar in concept to a `DataView`, a typed array is distinguished in that it enforces a single `ElementType` and obeys the system's native endianness. In exchange, it offers a much broader API and better performance. Typed arrays are designed for efficiently exchanging binary data with native libraries like WebGL. Because the binary representation of typed arrays is in an easily digestible format for the native operating system, JavaScript engines are able to heavily optimize arithmetic, bitwise, and other common operations on typed arrays, and as a result they are extremely fast to use.

Typed arrays can be created to read from an existing buffer, initialized with their own buffer, filled with an iterable, or filled from an existing typed array of any type. They can also be created using `<ElementType>.from()` and `<ElementType>.of()`:

```
// Creates a buffer of 12 bytes
const buf = new ArrayBuffer(12);
// Creates an Int32Array that references this buffer
const ints = new Int32Array(buf);
// The typed array recognizes it needs 4 bytes per element,
// and therefore will have a length of 3
alert(ints.length); // 3

// Creates an Int32Array of length 6
const ints2 = new Int32Array(6);
// Each number uses 4 bytes, so the ArrayBuffer is 24 bytes
alert(ints2.length); // 6
// Like DataView, typed arrays have a reference to their associated buffer
alert(ints2.buffer.byteLength); // 24

// Creates an Int32Array containing [2, 4, 6, 8]
const ints3 = new Int32Array([2, 4, 6, 8]);
alert(ints3.length); // 4
alert(ints3.buffer.byteLength); // 16
alert(ints3[2]); // 6

// Creates an Int16Array with values copied from ints3
const ints4 = new Int16Array(ints3);
// The new typed array allocates its own buffer, and each value
// is converted to its new representation at the same index
alert(ints4.length); // 4
alert(ints4.buffer.byteLength); // 8
alert(ints4[2]); // 6

// Creates an Int16Array from a normal array
const ints5 = Int16Array.from([3, 5, 7, 9]);
alert(ints5.length); // 4
alert(ints5.buffer.byteLength); // 8
alert(ints5[2]); // 7

// Creates a Float32Array from arguments
const floats = Float32Array.of(3.14, 2.718, 1.618);
alert(floats.length); // 3
alert(floats.buffer.byteLength); // 12
alert(floats[2]); // 1.6180000305175781
```

Both the constructor and instances expose a `BYTES_PER_ELEMENT` property that returns the size of each element in that type of array:

```
alert(Int16Array.BYTES_PER_ELEMENT); // 2
alert(Int32Array.BYTES_PER_ELEMENT); // 4

const ints = new Int32Array(1),
      floats = new Float64Array(1);

alert(ints.BYTES_PER_ELEMENT); // 4
alert(floats.BYTES_PER_ELEMENT); // 8
```

Unless a typed array is initialized with values, its associated buffer is filled with zeroes:

```
const ints = new Int32Array(4);
alert(ints[0]); // 0
alert(ints[1]); // 0
alert(ints[2]); // 0
alert(ints[3]); // 0
```

Typed Array Behavior

In most ways, typed arrays behave like their regular array counterparts would. Typed arrays support the following operators, methods, and properties:

- `[]`
- `copyWithin()`
- `entries()`
- `every()`
- `fill()`
- `filter()`
- `find()`
- `findIndex()`
- `forEach()`
- `indexOf()`
- `join()`
- `keys()`
- `lastIndexOf()`
- `length`
- `map()`
- `reduce()`
- `reduceRight()`
- `reverse()`

- slice()
- some()
- sort()
- toLocaleString()
- toString()
- values()

Methods that return a new array will return a new typed array with the same element type:

```
const ints = new Int16Array([1, 2, 3]);
const doubleints = ints.map(x => 2*x);
alert(doubleints instanceof Int16Array); // true
```

Typed arrays have a `Symbol.iterator` defined, meaning that `for...of` loops and spread operators can also be used:

```
const ints = new Int16Array([1, 2, 3]);
for (const int of ints) {
  alert(int);
}
// 1
// 2
// 3

alert(Math.max(...ints)); // 3
```

Merging, Copying, and Changing Typed Arrays

Typed arrays still use array buffers as their storage, and array buffers cannot be resized. Therefore, the following methods are not supported by typed arrays:

- concat()
- pop()
- push()
- shift()
- splice()
- unshift()

However, typed arrays do offer two new methods that allow you to copy values in and out of arrays quickly: `set()` and `subarray()`.

`set()` copies the values from a provided array or typed array into the current typed array at the specified index:

```
// Create an int16 array of length 8
const container = new Int16Array(8);
```



```

alert(concatArray); // [1, 2, 3, 4, 5, 6, 7, 8, 9]
alert(concatArray instanceof Int32Array); // true

```

Underflow and Overflow

Overflow and underflow of values in typed arrays will not spill over into other indices, but you still must take into account what element type the array considers its entries. Typed arrays will accept only the relevant bits that each index in the array can hold, irrespective of the effect it will have on the actual numerical value. The following demonstrates how underflow and overflow are handled:

```

// Signed ints array of length 2
// Each index holds a 2's complement signed integer which can
// range from -128 (-1 * 2^7) to 127 (2^7 - 1)
const ints = new Int8Array(2);

// Unsigned ints array of length 2
// Each index holds an unsigned integer which can range from
// 0 to 255 (2^7 - 1)
const unsignedInts = new Uint8Array(2);

// Overflow bits will not spill into adjacent indices.
// The index only takes the least significant 8 bits
unsignedInts[1] = 256; // 0x100
alert(unsignedInts); // [0, 0]
unsignedInts[1] = 511; // 0x1FF
alert(unsignedInts); // [0, 255]

// Underflow bits will be converted to their unsigned equivalent.
// 0xFF is -1 as a 2's complement int (truncated to 8 bits),
// but is 255 as an unsigned int
unsignedInts[1] = -1 // 0xFF (truncated to 8 bits)
alert(unsignedInts); // [0, 255]

// Overflow in 2's complement occurs transparently.
// 0x80 is 128 in unsigned int but -128 in 2's complement int
ints[1] = 128; // 0x80
alert(ints); // [0, -128]

// Underflow in 2's complement occurs transparently.
// 0xFF is 255 in unsigned int but -1 in 2's complement int
ints[1] = 255; // 0xFF
alert(ints); // [0, -1]

```

In addition to the eight element types, there is also an additional “clamped” array type, `Uint8ClampedArray`, which prevents overflow in either direction. Values above its maximum value of 255 will be rounded down to 255, and values below 0 will be rounded up to 0.

```

const clampedInts = new Uint8ClampedArray([-1, 0, 255, 256]);
alert(clampedInts); // [0, 0, 255, 255]

```

According to Brendan Eich, “`Uint8ClampedArray` is totally a historical artifact of the HTML5 canvas element. Avoid unless you really are doing canvas-y things.”

THE MAP TYPE

Prior to the ECMAScript 6 specification, implementing a key/value store in JavaScript could be accomplished effectively and easily by using an `Object`, using the object properties as keys and the property references the values. This style of implementation was not without its flaws, however, and therefore the TC39 committee saw fit to define a specification for a true key/value store.

Newly added in the ECMAScript 6, `Map` is a new collection type that introduces true key/value behavior into the language. Much of what it offers is an overlap with what is provided by the `Object` type, but there are subtle differences between the `Object` and `Map` types that should be taken into account when selecting one for use.

Basic API

An empty `Map` is instantiated with the new keyword:

```
const m = new Map();
```

If you wish to populate the `Map` when it is initialized, the constructor optionally accepts an iterable object, expecting it to contain key/value pair arrays. Each pair in the iterable argument will be inserted into the newly created `Map` in the order in which they are iterated:

```
// Initialize map with nested arrays
const m1 = new Map([
  ["key1", "val1"],
  ["key2", "val2"],
  ["key3", "val3"]
]);
alert(m1.size); // 3

// Initialize map with custom-defined iterator
const m2 = new Map({
  [Symbol.iterator]: function* () {
    yield ["key1", "val1"];
    yield ["key2", "val2"];
    yield ["key3", "val3"];
  }
});
alert(m2.size); // 3

// Map expects values to be key/value whether they are provided or not
const m3 = new Map([[ ]]);
alert(m3.has(undefined)); // true
alert(m3.get(undefined)); // undefined
```

Key/value pairs can be added after initialization with `set()`, queried with `get()` and `has()`, counted with the `size` property, and removed with `delete()` and `clear()`:

```
const m = new Map();

alert(m.has("firstName")); // false
alert(m.get("firstName ")); // undefined
alert(m.size); // 0
```

```
m.set("firstName", "Matt")
  .set("lastName", "Frisbie");

alert(m.has("firstName")); // true
alert(m.get("firstName")); // Matt
alert(m.size);             // 2

m.delete("firstName"); // deletes only this key/value pair

alert(m.has("firstName")); // false
alert(m.has("lastName")); // true
alert(m.size);             // 1

m.clear(); // destroys all key/value pairs in this Map instance

alert(m.has("firstName")); // false
alert(m.has("lastName")); // false
alert(m.size);             // 0
```

The `set()` method returns the `Map` instance, so it is possible to chain multiple `set` operations together, including on the initial declaration:

```
const m = new Map().set("key1", "val1");

m.set("key2", "val2")
  .set("key3", "val3");

alert(m.size); // 3
```

Unlike an `Object`, which can only use numbers or strings as keys, a `Map` can use any JavaScript data type as a key. It uses the “SameValueZero” comparison operation (defined inside the ECMAScript specification and not available in the actual language) and is mostly comparable to using strict object equivalence to check for a key match. As with `Objects`, there is no restriction on what is contained in the value.

```
const m = new Map();

const functionKey = function() {};
const symbolKey = Symbol();
const objectKey = new Object();

m.set(functionKey, "functionValue");
m.set(symbolKey, "symbolValue");
m.set(objectKey, "objectValue");

alert(m.get(functionKey)); // functionValue
alert(m.get(symbolKey));   // symbolValue
alert(m.get(objectKey));   // objectValue

// SameValueZero checks mean separate instances will not collide
alert(m.get(function() {})); // undefined
```

As with strict equivalence, objects and other “collection” types used for keys and values remain unchanged inside a `Map` when their contents or properties are altered:

```
const m = new Map();

const objKey = {},
      objVal = {},
      arrKey = [],
      arrVal = [];

m.set(objKey, objVal);
m.set(arrKey, arrVal);

objKey.foo = "foo";
objVal.bar = "bar";
arrKey.push("foo");
arrVal.push("bar");

alert(m.get(objKey)); // {bar: "bar"}
alert(m.get(arrKey)); // ["bar"]
```

The use of the `SameValueZero` operation may introduce unexpected collisions:

```
const m = new Map();

const a = 0/"", // NaN
      b = 0/"", // NaN
      pz = +0,
      nz = -0;

alert(a === b); // false
alert(pz === nz); // true

m.set(a, "foo");
m.set(pz, "bar");

alert(m.get(b)); // foo
alert(m.get(nz)); // bar
```

NOTE *The `SameValueZero` operation is new to the ECMAScript specification. There is an excellent writeup on it and other ECMAScript equality conventions on the Mozilla documentation site: https://developer.mozilla.org/en-US/docs/Web/JavaScript/Equality_comparisons_and_sameness.*

Order and Iteration

One major departure from the `Object` type’s conventions is that `Map` instances maintain the order of key/value insertion and allow you to perform iterative operations following insertion order.

A `Map` instance can provide an `Iterator` that contains array pairs in the form of `[key, value]` in insertion order. This iterator can be retrieved using `entries()`, or the `Symbol.iterator` property, which references `entries()`:

```
const m = new Map([
  ["key1", "val1"],
  ["key2", "val2"],
  ["key3", "val3"]
]);

alert(m.entries === m[Symbol.iterator]); // true

for (let pair of m.entries()) {
  alert(pair);
}
// [key1,val1]
// [key2,val2]
// [key3,val3]

for (let pair of m[Symbol.iterator]()) {
  alert(pair);
}
// [key1,val1]
// [key2,val2]
// [key3,val3]
```

Because `entries()` is the default iterator, the spread operator can be used to concisely convert a `Map` into an array:

```
const m = new Map([
  ["key1", "val1"],
  ["key2", "val2"],
  ["key3", "val3"]
]);

alert([...m]); // [[key1,val1],[key2,val2],[key3,val3]]
```

To use a callback convention instead of an iterator, `forEach(callback, opt_thisArg)` invokes the callback for each key/value pair. It optionally accepts a second argument, which will override the value of `this` inside each callback invocation.

```
const m = new Map([
  ["key1", "val1"],
  ["key2", "val2"],
  ["key3", "val3"]
]);

m.forEach((val, key) => alert(`${key} -> ${val}`));
// key1 -> val1
// key2 -> val2
// key3 -> val3
```

`keys()` and `values()` return an iterator that contains all keys or all values in the `Map` in insertion order:

```
const m = new Map([
  ["key1", "val1"],
  ["key2", "val2"],
  ["key3", "val3"]
]);

for (let key of m.keys()) {
  alert(key);
}
// key1
// key2
// key3

for (let key of m.values()) {
  alert(key);
}
// value1
// value2
// value3
```

Keys and values exposed inside an iterator are mutable, but the references inside the `Map` cannot be altered. However, this does not restrict changing properties inside a key or value object. Doing so will not alter their identity with respect to the `Map` instance:

```
const m1 = new Map([
  ["key1", "val1"]
]);

// String primitive as key is unaltered
for (let key of m1.keys()) {
  key = "newKey";
  alert(key); // newKey
  alert(m1.get("key1")); // val1
}

const keyObj = {id: 1};

const m = new Map([
  [keyObj, "val1"]
]);

// Key object property is altered, but the object still refers
// to the same value inside the map
for (let key of m.keys()) {
  key.id = "newKey";
  alert(key); // {id: "newKey"}
  alert(m.get(keyObj)); // val1
}
alert(keyObj); // {id: "newKey"}
```

Choosing Between Objects and Maps

For most web development purposes, selecting between a `Map` or a regular `Object` will be only a matter of preference and have little consequence elsewhere. However, for developers that care about memory and performance, there are notable differences between objects and maps that may be of interest.

Memory Profile

The engine-level implementation of `Object` and `Map` will obviously differ between browsers, but the amount of memory required to store a single key/value pair scales linearly with the number of keys. Bulk addition or removal of key/value pairs is also governed by how the engine implements memory allocation for that type. Results may vary by browser, but given a fixed amount of memory, a `Map` will be able to store roughly 50 percent more key/value pairs than an `Object`.

Insertion Performance

Inserting a new key/value pair into an `Object` versus a `Map` is a roughly comparable operation, but insertion into a `Map` will generally be slightly faster across all browser engines. For both types, the speed of an insertion does not scale linearly with the number of key/value pairs in the `Object` or `Map`. If your code is heavy on insert operations, `Map` instances offer superior performance.

Lookup Performance

Unlike insertion, looking up a key/value pair in an `Object` versus a `Map` is a roughly comparable operation at scale, but a smaller number of key/value pairs favor `Object` instances in some situations. In situations where an `Object` instance is being used like an array (for example, consecutive integer properties), the browser engine can perform optimizations such as more efficient layout in memory—this is never possible with a `Map`. For both types, lookup speed does not scale linearly with the number of key/value pairs in an `Object` or `Map`. If your code is heavy on lookup operations, in some scenarios it may be more advantageous to use an `Object`.

Delete Performance

The performance of the `delete` operation on `Object` properties is notorious for being horrendous, and this is still very much the case in many browser engines. Workarounds for pseudo-deleting object properties include assigning `undefined` or `null` as the property value, but in many cases this is an obnoxious or unsuitable compromise. Across most browser engines, the `Map` `delete()` operation is faster than insert and lookup. If your code is heavy on `delete` operations, the `Map` type is the overwhelming favorite.

THE WEAKMAP TYPE

Newly added in the ECMAScript 6, `WeakMap` is a new collection type that introduces augmented key/value behavior into the language. The `WeakMap` type is a cousin to the `Map` type, and its API is a strict subset of `Map`. The “weak” designation describes how JavaScript’s garbage collector treats keys in a `WeakMap`.

Basic API

An empty `WeakMap` is instantiated with the new keyword:

```
const wm = new WeakMap();
```

Keys in a `WeakMap` can only be of type `Object` or inherit from `Object`—all other attempts to set a key with a non-object will throw a `TypeError`. There are no restrictions on the type of the value.

If you wish to populate the `WeakMap` when it is initialized, the constructor optionally accepts an iterable object, expecting it to contain valid key/value pair arrays. Each pair in the iterable argument will be inserted into the newly created `WeakMap` in the order in which they are iterated:

```
const key1 = {id: 1},
      key2 = {id: 2},
      key3 = {id: 3};
// Initialize WeakMap with nested arrays
const wm1 = new WeakMap([
  [key1, "val1"],
  [key2, "val2"],
  [key3, "val3"]
]);
alert(wm1.get(key1)); // val2
alert(wm1.get(key2)); // val2
alert(wm1.get(key3)); // val3

// Initialization is all-or-nothing, a single bad key will
// throw an error and abort the initialization
const wm2 = new WeakMap([
  [key1, "val1"],
  ["BADKEY", "val2"],
  [key3, "val3"]
]);
// TypeError: Invalid value used as WeakMap key
typeof wm2;
// ReferenceError: wm2 is not defined

// Primitives can still be used with an object wrapper
const stringKey = new String("key1");
const wm3 = new WeakMap([
  [stringKey, "val1"]
]);
alert(wm3.get(stringKey)); // "val1"
```

Key/value pairs can be added after initialization with `set()`, queried with `get()` and `has()`, and removed with `delete()`:

```
const wm = new WeakMap();

const key1 = {id: 1},
      key2 = {id: 2};

alert(wm.has(key1)); // false
alert(wm.get(key1)); // undefined
```

```
wm.set(key1, "Matt")
  .set(key2, "Frisbie");

alert(wm.has(key1)); // true
alert(wm.get(key1)); // Matt

wm.delete(key1); // deletes only this key/value pair

alert(wm.has(key1)); // false
alert(wm.has(key2)); // true
```

The `set()` method returns the `WeakMap` instance, so it is possible to chain multiple set operations together, including on the initial declaration:

```
const key1 = {id: 1},
      key2 = {id: 2},
      key3 = {id: 3};

const wm = new WeakMap().set(key1, "val1");

wm.set(key2, "val2")
  .set(key3, "val3");

alert(wm.get(key1)); // val1
alert(wm.get(key2)); // val2
alert(wm.get(key3)); // val3
```

Weak Keys

The “weak” designation stems from the fact that keys in a `WeakMap` are “weakly held,” meaning they are not counted as formal references that would otherwise prevent garbage collection. An important distinction for the `WeakMap` is that the value reference is *not* weakly held. As long as the key exists, the key/value pair will remain in the map and count as a reference to the value—thereby preventing it from being garbage collected.

Consider the following example:

```
const wm = new WeakMap();

wm.set({}, "val");
```

Inside `set()`, a fresh object is initialized and used as a key to a dummy string. Because there are no other references to this object, as soon as this line is finished executing, the object key will be free for garbage collection. When this occurs, the key/value pair will disappear from the `WeakMap`, and it will be empty. In this example, because there are no other references to the value, this key/value destruction will also mean that the value is eligible for garbage collection.

Consider a slightly different example:

```
const wm = new WeakMap();

const container = {
  key: {}
};
```

```

wm.set(container.key, "val");

function removeReference()
  container.key = null;
}

```

Here, the `container` object maintains a reference to the key in the `WeakMap`, so the object is ineligible for garbage collection. However, as soon as `removeReference()` is invoked, the last strong reference to the key object will be destroyed, and garbage collection will eventually wipe out the key/value pair.

Non-Iterable Keys

Because key/value pairs in a `WeakMap` can be destroyed at any time, it does not make sense to offer the ability to iterate through the key/value pairs. This also excludes the ability to destroy all key/value pairs at once using `clear()`, which is not part of the `WeakMap` API. Because iteration is not possible, it is also not possible to retrieve a value from a `WeakMap` instance unless you have a reference to the key object. Even if code has access to the `WeakMap` instance, there is no way to inspect its contents.

The reason that `WeakMap` instances restrict keys to only objects is to preserve the convention that values can only be retrieved from a `WeakMap` with a reference to the key object. If primitives were allowed, the `WeakMap` instance would have no way of differentiating between the string primitive that was initially used to set the key/value pair and an identical string primitive that was initialized later—an undesirable behavior.

Utility

`WeakMap` instances are a striking departure from existing JavaScript tools, and it may not be immediately obvious how they ought to be used. There is no single answer to this, but a number of strategies have already emerged.

Private Variables

`WeakMap` instances engender an entirely new way of implementing truly private variables in JavaScript. The premise is relatively straightforward: private variables will be stored in a `WeakMap` with the object instance as the key and a dictionary of private members as the value.

One implementation is as follows:

```

const wm = new WeakMap();

class User {
  constructor(id) {
    this.idProperty = Symbol('id');
    this.setId(id);
  }

  setPrivate(property, value) {
    const privateMembers = wm.get(this) || {};
    privateMembers[property] = value;
    wm.set(this, privateMembers);
  }
}

```

```
getPrivate(property) {
  return wm.get(this) [property];
}

setId(id) {
  this.setPrivate(this.idProperty, id);
}

getId() {
  return this.getPrivate(this.idProperty);
}

const user = new User(123);
alert(user.getId()); // 123
user.setId(456);
alert(user.getId()); // 456

// Demonstrating it's not really private
alert(wm.get(user) [user.idProperty]); // 456
```

The observant developer will note that, with this implementation, foreign code needs only a reference to the object instance and the `WeakMap` to retrieve the “private” variables. To prevent this, the `WeakMap` can be wrapped in a closure to totally hide the `WeakMap` instance from outside code.

```
const User = (() => {
  const wm = new WeakMap();

  class User {
    constructor(id) {
      this.idProperty = Symbol('id');
      this.setId(id);
    }

    setPrivate(property, value) {
      const privateMembers = wm.get(this) || {};
      privateMembers[property] = value;
      wm.set(this, privateMembers);
    }

    getPrivate(property) {
      return wm.get(this) [property];
    }

    setId(id) {
      this.setPrivate(this.idProperty, id);
    }

    getId(id) {
      return this.getPrivate(this.idProperty);
    }
  }
  return User;
})();
```



```
const user = new User(123);
alert(user.getId()); // 123
user.setId(456);
alert(user.getId()); // 456
```

Therefore, a value in a `WeakMap` cannot be retrieved without the key that was used to insert it. Although, this prevents the aforementioned pattern of access, in some ways it has pushed the code full-circle to the pre-ES6 closure private variable pattern.

DOM Node Metadata

Because `WeakMap` instances do not interfere with garbage collection, they are a terrific tool for cleanup-free metadata association. Consider the following example, which uses a regular `Map`:

```
const m = new Map();

const loginButton = document.querySelector('#login');

// Associates some metadata with the node
m.set(loginButton, {disabled: true});
```

Suppose after this code executes, the page is changed by JavaScript and the login button is removed from the DOM tree. Because a reference exists inside the `Map`, the DOM node will linger in memory in perpetuity until explicitly removed from the `Map`, or until the `Map` is destroyed.

If, instead, a `WeakMap` was used, as shown in the following code, the node's removal from the DOM would allow the garbage collector to free the allocated memory immediately (assuming no other lingering references to the object).

```
const wm = new WeakMap();

const loginButton = document.querySelector('#login');

// Associates some metadata with the node
wm.set(loginButton, {disabled: true});
```

THE SET TYPE

Newly added in the ECMAScript 6, `Set` is a new collection type that introduces set behavior into the language. A `Set` in many ways behaves more like an augmented `Map`, as much of the API and behavior is shared.

Basic API

An empty `Set` is instantiated with the `new` keyword:

```
const m = new Set();
```

If you wish to populate the map when it is initialized, the constructor optionally accepts an iterable object containing elements to be added into the newly created `Set` instance.

```
// Initialize set with array
const s1 = new Set(["val1", "val2", "val3"]);
```

```
    alert(s1.size); // 3

    // Initialize set with custom-defined iterator
    const s2 = new Set({
      [Symbol.iterator]: function*() {
        yield "val1";
        yield "val2";
        yield "val3";
      }
    });
    alert(s2.size); // 3
```

Values can be added after initialization with `add()`, queried with `has()`, counted with the `size` property, and removed with `delete()` and `clear()`:

```
const s = new Set();

alert(s.has("Matt")); // false
alert(s.size); // 0

s.add("Matt")
  .add("Frisbie");

alert(s.has("Matt")); // true
alert(s.size); // 2

s.delete("Matt");

alert(s.has("Matt")); // false
alert(s.has("Frisbie")); // true
alert(s.size); // 1

s.clear(); // destroys all values in this Set instance

alert(s.has("Matt")); // false
alert(s.has("Frisbie")); // false
alert(s.size); // 0
```

The `add()` method returns the `Set` instance, so it is possible to chain multiple operations together, including on the initial declaration:

```
const s = new Set().add("val1");

s.set("val2")
  .set("val3");

alert(s.size); // 3
```

Like `Map`, a `Set` can contain any JavaScript data type as a value. It uses the “SameValueZero” comparison operation (defined inside the ECMAScript specification and not available in the actual language) and is mostly comparable to using strict object equivalence to check for a key match. There is no restriction on what is contained in the value.

```
const s = new Set();

const functionVal = function() {};
```

```

const symbolVal = Symbol();
const objectVal = new Object();

s.add(functionVal);
s.add(symbolVal);
s.add(objectVal);

alert(s.has(functionVal)); // true
alert(s.has(symbolVal)); // true
alert(s.has(objectVal)); // true

// SameValueZero checks mean separate instances will not collide
alert(s.has(function() {})); // false

```

As with strict equivalence, objects and other “collection” types used for values remain unchanged inside a set when their contents or properties are altered:

```

const s = new Set();

const objVal = {},
      arrVal = [];

s.add(objVal);
  .add(arrVal);

objVal.bar = "bar";
arrVal.push("bar");

alert(s.has(objVal)); // true
alert(s.has(arrVal)); // true

```

The `add()` and `delete()` operations are idempotent. `delete()` returns a Boolean indicating if that value was present in the set.

```

const s = new Set();

s.add('foo');
alert(s.size); // 1
s.add('foo');
alert(s.size); // 1

// Value was present in the set
alert(s.delete('foo')); // true

// Value was not present in the set
alert(s.delete('foo')); // false

```

Order and Iteration

Sets maintain the order of value insertion and allow you to perform iterative operations following insertion order.

A Set instance can provide an Iterator that contains the set contents in insertion order. This iterator can be retrieved using `values()`, its alias `keys()`, or the `Symbol.iterator` property, which references `values()`:

```
const s = new Set(["val1", "val2", "val3"]);

alert(s.values === s[Symbol.iterator]); // true
alert(s.keys === s[Symbol.iterator]);  // true

for (let value of s.values()) {
  alert(value);
}
// val1
// val2
// val3

for (let value of s[Symbol.iterator]()) {
  alert(value);
}
// val1
// val2
// val3
```

Because `values()` is the default iterator, the spread operator can be used to concisely convert a set into an array:

```
const s = new Set(["val1", "val2", "val3"]);

alert([...s]); // [val1, val2, val3]
```

`entries()` returns an iterator that contains a two-element array containing a duplicate of all values in the Set in insertion order:

```
const s = new Set(["val1", "val2", "val3"]);

for (let pair of s.entries()) {
  alert(pair);
}
// [val1, val1]
// [val2, val2]
// [val3, val3]
```

To use a callback convention instead of an iterator, `forEach(callback, opt_thisArg)` invokes the callback for each value. It optionally accepts a second argument, which will override the value of `this` inside each callback invocation.

```
const s = new Set(["val1", "val2", "val3"]);

s.forEach((val, dupVal) => alert(`${val} -> ${dupVal}`));
// val1 -> val1
// val2 -> val2
// val3 -> val3
```

Changing properties of values in a `Set` does not alter the value's identity with respect to the `Set` instance:

```
const s1 = new Set(["val1"]);

// String primitive as value is unaltered
for (let value of m.values()) {
  value = "newVal";
  alert(value);           // newVal
  alert(s.has("val1"));  // true
}

const valObj = {id: 1};

const s2 = new Set([valObj]);

// Value object property is altered, but the object still exists
// inside the set
for (let value of s.values()) {
  value.id = "newVal";
  alert(value);           // {id: "newVal"}
  alert(s.has(valObj));  // true
}
alert(valObj);           // {id: "newKey"}
```

Defining Formal Set Operations

In many ways, `Set` feels like `Map` with its API slightly rearranged. This is only underscored by the fact that its API only supports self-referential operations. Many developers will have an appetite for using `Set` operations. This requires manual implementation, and it can either take the form of a subclassing `Set` or defining a utility library. To offer flavors of both at once, you can implement static methods on a subclass and then use those static methods in the instance methods. When implementing these operations, there are some points to keep in mind:

- Some `Set` operations are associative, so it is advantageous to be able to implement the method so it can handle an arbitrary number of `Set` instances.
- A `Set` preserves insertion order, and the sets that are returned from these methods should reflect that fact.
- Use memory efficiently wherever possible. Spread operators offer nice syntax, but avoid switching back and forth between sets and arrays wherever possible to save on object initialization costs.
- Don't mutate existing `Set` instances. `union(a, b)` or `a.union(b)` should return a new `Set` instance with the result.

```
class XSet extends Set {
  union(...sets) {
    return XSet.union(this, ...sets)
  }
}
```

```
intersection(...sets) {
    return XSet.intersection(this, ...sets);
}

difference(set) {
    return XSet.difference(this, set);
}

symmetricDifference(set) {
    return XSet.symmetricDifference(this, set);
}

cartesianProduct(set) {
    return XSet.cartesianProduct(this, set);
}

powerSet() {
    return XSet.powerSet(this);
}

// Returns union of two or more sets.
static union(a, ...bSets) {
    const unionSet = new XSet(a);
    for (const b of bSets) {
        for (const bValue of b) {
            unionSet.add(bValue);
        }
    }
    return unionSet;
}

// Returns intersection of two or more sets.
static intersection(a, ...bSets) {
    const intersectionSet = new XSet(a);
    for (const aValue of intersectionSet) {
        for (const b of bSets) {
            if (!b.has(aValue)) {
                intersectionSet.delete(aValue);
            }
        }
    }
    return intersectionSet;
}

// Returns difference of exactly two sets.
static difference(a, b) {
    const differenceSet = new XSet(a);
    for (const bValue of b) {
        if (a.has(bValue)) {
            differenceSet.delete(bValue);
        }
    }
    return differenceSet;
}
```

```

// Returns symmetric difference of exactly two sets.
static symmetricDifference(a, b) {
  // By definition, the symmetric difference can be expressed as
  // (a union b) - (a intersection b)
  return a.union(b).difference(a.intersection(b));
}

// Returns cartesian product (as array pairs) of exactly two sets.
// Must return set of arrays since cartesian product may contain
// pairs of identical values.
static cartesianProduct(a, b) {
  const cartesianProductSet = new XSet();
  for (const aValue of a) {
    for (const bValue of b) {
      cartesianProductSet.add([aValue, bValue]);
    }
  }
  return cartesianProductSet;
}

// Returns power set of exactly one set.
static powerSet(a) {
  const powerSet = new XSet().add(new XSet());
  for (const aValue of a) {
    for (const set of new XSet(powerSet)) {
      powerSet.add(new XSet(set).add(aValue));
    }
  }
  return powerSet;
}
}

```

THE WEAKSET TYPE

Newly added in the ECMAScript 6, `WeakSet` is a new collection type that introduces set behavior into the language. The `WeakSet` type is a cousin to the `Set` type, and its API is a strict subset of `Set`. The “weak” designation describes how JavaScript’s garbage collector treats values in a weak map.

Basic API

An empty `WeakSet` instance is instantiated with the `new` keyword:

```
const ws = new WeakSet();
```

Values in a `WeakSet` can only be of type `object` or inherit from `Object`—all other attempts to set a value with a non-object will throw a `TypeError`.

If you wish to populate the `WeakSet` when it is initialized, the constructor optionally accepts an iterable object, expecting it to contain valid values. Each value in the iterable argument will be inserted into the newly created `WeakSet` in the order in which they are iterated:

```
const val1 = {id: 1},
      val2 = {id: 2},
```

```
    val3 = {id: 3};
// Initialize WeakSet with nested arrays
const ws1 = new WeakSet([val1, val2, val3]);

alert(ws1.has(val1)); // true
alert(ws1.has(val2)); // true
alert(ws1.has(val3)); // true

// Initialization is all-or-nothing, a single bad value will
// throw an error and abort the initialization
const ws2 = new WeakSet([val1, "BADVAL", val3]);
// TypeError: Invalid value used in WeakSet
typeof ws2;
// ReferenceError: ws2 is not defined

// Primitives can still be used with an object wrapper
const stringVal = new String("val1");
const ws3 = new WeakSet([stringVal]);
alert(ws3.has(stringVal)); // true
```

Values can be added after initialization with `add()`, queried with `has()`, and removed with `delete()`:

```
const ws = new WeakSet();

const val1 = {id: 1},
      val2 = {id: 2};

alert(ws.has(val1)); // false

ws.add(val1)
  .add(val2);

alert(ws.has(val1)); // true
alert(ws.has(val2)); // true

ws.delete(val1); // deletes only this value

alert(ws.has(val1)); // false
alert(ws.has(val2)); // true
```

The `add()` method returns the `WeakSet` instance, so it is possible to chain multiple `add` operations together, including on the initial declaration:

```
const val1 = {id: 1},
      val2 = {id: 2},
      val3 = {id: 3};

const ws = new WeakSet().add(val1);

ws.add(val2)
  .add(val3);

alert(ws.has(val1)); // true
alert(ws.has(val2)); // true
alert(ws.has(val3)); // true
```

Weak Keys

The “weak” designation stems from the fact that values in a `WeakSet` are “weakly held,” meaning they are not counted as formal references, which would otherwise prevent garbage collection.

Consider the following example:

```
const ws = new WeakSet();

ws.add({});
```

Inside `add()`, a fresh object is initialized and used as a value. Because there are no other references to this object, as soon as this line is finished executing, the object value will be free for garbage collection. When this occurs, the value will disappear from the `WeakSet`, and it will be empty.

Consider a slightly different example:

```
const ws = new WeakSet();

const container = {
  val: {}
};

ws.add(container.val);

function removeReference()
  container.val = null;
}
```

Here, the `container` object maintains a reference to the value in the `WeakSet` instance, so the object is ineligible for garbage collection. However, as soon as `removeReference()` is invoked, the last strong reference to the value object will be destroyed, and garbage collection will eventually wipe out the value.

Non-Iterable Values

Because values in a `WeakSet` can be destroyed at any time, it does not make sense to offer the ability to iterate through the values. This also excludes the ability to destroy all values at once using `clear()`, which is not part of the `WeakSet` API. Because iteration is not possible, it is also not possible to retrieve a value from a `WeakSet` instance unless you have a reference to the value object. Even if code has access to the `WeakSet` instance, there is no way to inspect its contents.

`WeakMap` instances restrict keys to only objects in order to preserve the convention that values can only be retrieved from a `WeakSet` with a reference to the value object. If primitives were allowed, the `WeakSet` would have no way of differentiating between the string primitive that was initially used to set the value and an identical string primitive that was initialized later—an undesirable behavior.

Utility

`WeakSet` instances are more limited in their usefulness when compared to `WeakMap` instances, but they still are valuable to use for tagging objects.

Consider the following example, which uses a regular Set:

```
const disabledElements = new Set();

const loginButton = document.querySelector('#login');

// Tags the node as "disabled" by adding it to the corresponding set
disabledElements.add(loginButton);
```

Here, it is possible to check if an element is disabled by seeing if it exists inside `disabledElements`, which can be done in constant time. However, if the element is removed from the DOM, its presence inside this Set will prevent garbage collection from reallocating its memory.

To allow the garbage collection to reallocate the element's memory a `WeakSet` can instead be used:

```
const disabledElements = new WeakSet();

const loginButton = document.querySelector('#login');

// Tags the node as "disabled" by adding it to the corresponding set
disabledElements.add(loginButton);
```

Now, when any element in the `WeakSet` is removed from the DOM, the garbage collector will ignore its presence inside the `WeakSet` when considering it for garbage collection.

ITERATION AND SPREAD OPERATORS

ECMAScript 6 introduced iterators and the spread operator, which are especially useful in the context of collection reference types. These new tools allow for easy interoperability, cloning, and modification of collection types.

NOTE *The Iterators and Generators chapter offers more coverage on exactly how iterators work.*

As shown earlier in the chapter, four native collection reference types define a default iterator:

```
Array
All typed arrays
Map
Set
```

Trivially, this means that all support ordered iteration and can be passed to a `for...of` loop:

```
let iterableThings = [
  Array.of(1, 2),
  typedArr = Int16Array.of(3, 4),
  new Map([[5, 6], [7, 8]]),
  new Set([9, 10])
];
```

```

for (const iterableThing of iterableThings) {
  for (const x of iterableThing) {
    console.log(x);
  }
}

// 1
// 2
// 3
// 4
// [5, 6]
// [7, 8]
// 9
// 10

```

This also means that all these types are compatible with the spread operator. The spread operator is especially useful as it performs a shallow copy on the iterable object. This allows you to easily clone entire objects with a succinct syntax:

```

let arr1 = [1, 2, 3];
let arr2 = [...arr1];

console.log(arr1);           // [1, 2, 3]
console.log(arr2);           // [1, 2, 3]
console.log(arr1 === arr2); // false

```

Constructors which expect an iterable object can just be passed the iterable instance to be cloned:

```

let map1 = new Map([[1, 2], [3, 4]]);
let map2 = new Map(map1);

console.log(map1); // Map {1 => 2, 3 => 4}
console.log(map2); // Map {1 => 2, 3 => 4}

```

It also allows for partial array construction:

```

let arr1 = [1, 2, 3];
let arr2 = [0, ...arr1, 4, 5];

console.log(arr2); // [0, 1, 2, 3, 4, 5]

```

The shallow copy mechanism means that only object references are copied:

```

let arr1 = [{}];
let arr2 = [...arr1];

arr1[0].foo = 'bar';
console.log(arr2[0]); // { foo: 'bar' }

```

Each of these collection types support multiple methods of construction, such as the `Array.of()` and `Array.from()` static methods. When combined with the spread operator, this makes for extremely easy interoperability:

```

let arr1 = [1, 2, 3];

// Copy array into typed array

```

```
let typedArr1 = Int16Array.of(...arr1);
let typedArr2 = Int16Array.from(arr1);
console.log(typedArr1); // Int16Array [1, 2, 3]
console.log(typedArr2); // Int16Array [1, 2, 3]

// Copy array into map
let map = new Map(arr1.map((x) => [x, `val` + x]));
console.log(map); // Map {1 => `val 1`, 2 => `val 2`, 3 => `val 3`}

// Copy array in to set
let set = new Set(typedArr2);
console.log(set); // Set {1, 2, 3}

// Copy set back into array
let arr2 = [...set];
console.log(arr2); // [1, 2, 3]
```

SUMMARY

Objects in JavaScript are called reference values, and several built-in reference types can be used to create specific types of objects, as follows:

- Reference types are similar to classes in traditional object-oriented programming but are implemented differently.
- The `Object` type is the base from which all other reference types inherit basic behavior.
- The `Array` type represents an ordered list of values and provides functionality for manipulating and converting the values.
- Typed arrays encompass a range of different reference types that involve type management of numbers in memory.
- The `Date` type provides information about dates and times, including the current date and time and calculations.
- The `RegExp` type is an interface for regular-expression support in ECMAScript, providing most basic and some advanced regular-expression functionality.

One of the unique aspects of JavaScript is that functions are actually instances of the `Function` type, meaning functions are objects. Because functions are objects, functions have methods that can be used to augment how they behave.

Because of the existence of primitive wrapper types, primitive values in JavaScript can be accessed as if they were objects. There are three primitive wrapper types: `Boolean`, `Number`, and `String`. They all have the following characteristics:

- Each of the wrapper types maps to the primitive type of the same name.
- When a primitive value is accessed in read mode, a primitive wrapper object is instantiated so that it can be used to manipulate the data.
- As soon as a statement involving a primitive value is executed, the wrapper object is destroyed.

There are also two built-in objects that exist at the beginning of code execution: `Global` and `Math`. The `Global` object isn't accessible in most ECMAScript implementations; however, web browsers implement it as the `window` object. The `Global` object contains all global variables and functions as properties. The `Math` object contains properties and methods to aid in complex mathematical calculations.

ECMAScript 6 introduced a handful of collection types: `Map`, `WeakMap`, `Set`, and `WeakSet`. These offer new possibilities for organizing application data as well as easier memory management.

7

Iterators and Generators

WHAT'S IN THIS CHAPTER?

- Introduction to iteration
- The iterator pattern
- Generators

WROX.COM DOWNLOADS FOR THIS CHAPTER

Please note that all the code examples for this chapter are available as a part of this chapter's code download on the book's website at www.wrox.com/go/projavascript4e on the Download Code tab.

The term “iteration” is derived from the Latin *itero*, meaning “repeat” or “do again.” In the context of software, “iteration” means repetitively performing a procedure multiple times, in sequence, and usually with an expectation of termination. The ECMAScript 6 specification introduces two high-level features—iterators and generators—to allow for cleaner, faster, and easier iteration.

INTRODUCTION TO ITERATION

In JavaScript, one of the simplest examples of iteration is a counting loop:

```
for (let i = 1; i <= 10; ++i) {  
  console.log(i);  
}
```

Loops are a fundamental iterative tool because they allow you to specify how many iterations should occur and what should occur during each iteration. Each loop iteration will finish execution before another begins, and the order in which each iteration occurs is well-defined.

Iteration can occur over ordered collections of items. (Consider “ordered” in this context to imply there is an accepted sequence in which all the items should be traversed, with a definitive beginning and end item.) In JavaScript, the most common example of this ordered collection is an array.

```
let collection = ['foo', 'bar', 'baz'];

for (let index = 0; index < collection.length; ++index) {
  console.log(collection[index]);
}
```

Because an array has a known length, and because each item in that array can be retrieved via its index, the entire array can be traversed in order by incrementing the range of possible indices.

The fundamental procedure occurring in such a loop is not ideal for several reasons:

- **Iterating through the data structure requires a specific knowledge of how to use the data structure.** Each item in the array can only be retrieved by first referencing the array object and then retrieving an item at a specific index using the `[]` operator. This does not generalize to other data structures.
- **The order of traversal is not inherent to the data structure.** Incrementing an integer to access sequential indices is specific to the array type and does not generalize to other data structures that have an implicit ordering.

ES5 introduced the `Array.prototype.forEach` method, which is closer to what is needed (but still not an ideal solution):

```
let collection = ['foo', 'bar', 'baz'];

collection.forEach((item) => console.log(item));
// foo
// bar
// baz
```

This solves the problem of separately tracking an index and retrieving items via the array object. However, there is no way to terminate this iteration; the method is limited to arrays, and the callback structure is unwieldy.

With earlier versions of ECMAScript, performing iteration required the use of loops or other auxiliary constructs, which is an increasingly messy affair as code complexity scales. Many languages have addressed this problem with a native language construct that allows iteration to be performed without specific knowledge of how the iteration was actually occurring, and the solution is the *iterator pattern*. Python, Java, C++, and many other languages offer first-class support for this pattern, and JavaScript, too, with the ES6 specification.

THE ITERATOR PATTERN

The *iterator pattern* (specifically in the context of ECMAScript) describes a solution in which something can be described as “iterable” and can implement a formal `Iterable` interface and consumed by an `Iterator`.

The concept of an “iterable” is intentionally abstract. Frequently, the iterable will take the form of a collection object like an array or set, both of which have a finite number of countable elements and feature an unambiguous order of traversal:

```
// Arrays have finite countable elements
// In-order traversal visits each index in increasing index order
let arr = [3, 1, 4];

// Sets have finite countable elements
// In-order traversal visits each value in insertion order
let set = new Set().add(3).add(1).add(4);
```

However, an iterable does not have to be linked to a collection object. It can also be linked to something that only behaves like an array—such as the counting loop from earlier in the chapter. The values generated in this loop are transient, and yet such a loop is performing iteration. Both this counting loop and an array can behave as an iterable.

NOTE *Transient iterables can be implemented as generators, which are covered later in the chapter.*

Anything that implements the `Iterable` interface can be “consumed” by an object that implements the `Iterator` interface. An *iterator* is a separate object created on demand and intended for a single use. Each iterator is associated with an *iterable*, and the iterator exposes an API to iterate through the associated iterable a single time. The iterator doesn’t need to understand the structure of the iterable it is associated with; it only must know how to retrieve sequential values. This separation of concerns is what makes the `Iterable/Iterator` convention so useful.

The Iterable Protocol

Implementing the `Iterable` interface requires both the capability to self-identify as supporting iteration and the capability to create an object that implements the `Iterator` interface. In ECMAScript, this means it must expose a property, the “default iterator,” keyed with the special `Symbol.iterator` key. This default iterator property must refer to an iterator factory function, which will produce a new iterator when invoked.

Many built-in types implement the `Iterable` interface:

- Strings
- Arrays
- Maps
- Sets
- The `arguments` object
- Some DOM collection types like `NodeList`

Checking for the existence of this default iterator property will expose the factory function:

```
let num = 1;
let obj = {};

// These types do not have iterator factories
console.log(num[Symbol.iterator]); // undefined
console.log(obj[Symbol.iterator]); // undefined

let str = 'abc';
let arr = ['a', 'b', 'c'];
let map = new Map().set('a', 1).set('b', 2).set('c', 3);
let set = new Set().add('a').add('b').add('c');
let els = document.querySelectorAll('div');

// These types all have iterator factories
console.log(str[Symbol.iterator]); // f values() { [native code] }
console.log(arr[Symbol.iterator]); // f values() { [native code] }
console.log(map[Symbol.iterator]); // f values() { [native code] }
console.log(set[Symbol.iterator]); // f values() { [native code] }
console.log(els[Symbol.iterator]); // f values() { [native code] }

// Invoking the factory function produces an Iterator
console.log(str[Symbol.iterator]()); // StringIterator {}
console.log(arr[Symbol.iterator]()); // ArrayIterator {}
console.log(map[Symbol.iterator]()); // MapIterator {}
console.log(set[Symbol.iterator]()); // SetIterator {}
console.log(els[Symbol.iterator]()); // ArrayIterator {}
```

You do not necessarily need to explicitly invoke this factory function to produce an iterator. Anything that implements this protocol is automatically compatible with any language features that accept an iterable. These native language constructs include:

- `for...of` loop
- Array destructuring
- The spread operator
- `Array.from()`
- Set construction
- Map construction
- `Promise.all()`, which expects an iterable of promises
- `Promise.race()`, which expects an iterable of promises
- The `yield*` operator, used in generators

Behind the scenes, these native language constructs are invoking the factory function of the provided iterable to create an iterator:

```
let arr = ['foo', 'bar', 'baz'];

// for...of loops
for (let el of arr) {
  console.log(el);
}
```

```

}
// foo
// bar
// baz

// Array destructuring
let [a, b, c] = arr;
console.log(a, b, c); // foo, bar, baz

// Spread operator
let arr2 = [...arr];
console.log(arr2); // ['foo', 'bar', 'baz']

// Array.from()
let arr3 = Array.from(arr);
console.log(arr3); // ['foo', 'bar', 'baz']

// Set constructor
let set = new Set(arr);
console.log(set); // Set(3) {'foo', 'bar', 'baz'}

// Map constructor
let pairs = arr.map((x, i) => [x, i]);
console.log(pairs); // [['foo', 0], ['bar', 1], ['baz', 2]]
let map = new Map(pairs);
console.log(map); // Map(3) { 'foo'=>0, 'bar'=>1, 'baz'=>2 }

```

An object still implements the `Iterable` interface if a parent class up the prototype chain implements the interface:

```

class FooArray extends Array {}
let fooArr = new FooArray('foo', 'bar', 'baz');

for (let el of fooArr) {
  console.log(el);
}
// foo
// bar
// baz

```

The Iterator Protocol

An iterator is a single-use object that will iterate through whatever iterable it is associated with. The Iterator API uses a `next()` method to advance through the iterable. Each successive time `next()` is invoked, it will return an `IteratorResult` object containing the next value in the iterator. The current position the iterator is at cannot be known without invoking the `next()` method.

The `next()` method returns an object with two properties: `done`, which is a Boolean indicating if `next()` can be invoked again to retrieve more values, and `value`, which will contain the next value in the iterable or undefined if `done` is true. The `done:true` state is termed “exhaustion.” This can be demonstrated with a simple array:

```

// Iterable object
let arr = ['foo', 'bar'];

```

```

// Iterator factory
console.log(arr[Symbol.iterator]); // f values() { [native code] }

// Iterator
let iter = arr[Symbol.iterator]();
console.log(iter); // ArrayIterator {}

// Performing iteration
console.log(iter.next()); // { done: false, value: 'foo' }
console.log(iter.next()); // { done: false, value: 'bar' }
console.log(iter.next()); // { done: true, value: undefined }

```

Arrays are iterated in order by creating an iterator and invoking `next()` until it ceases to produce new values. Note how the iterator does not know how to retrieve the next values inside the iterable, nor does it know how large the iterable is. Once the iterator reaches the `done:true` state, invoking `next()` is idempotent:

```

let arr = ['foo'];
let iter = arr[Symbol.iterator]();
console.log(iter.next()); // { done: false, value: 'foo' }
console.log(iter.next()); // { done: true, value: undefined }
console.log(iter.next()); // { done: true, value: undefined }
console.log(iter.next()); // { done: true, value: undefined }

```

Each iterator represents a one-time ordered traversal of the iterable. Different instances are not aware of each other and will independently traverse the iterable:

```

let arr = ['foo', 'bar'];
let iter1 = arr[Symbol.iterator]();
let iter2 = arr[Symbol.iterator]();

console.log(iter1.next()); // { done: false, value: 'foo' }
console.log(iter2.next()); // { done: false, value: 'foo' }
console.log(iter2.next()); // { done: false, value: 'bar' }
console.log(iter1.next()); // { done: false, value: 'bar' }

```

An iterator is not bound to a snapshot of the iterable; it merely uses a cursor to track its progress through the iterable. If the iterable is mutated during iteration, the iterator will incorporate the changes:

```

let arr = ['foo', 'baz'];
let iter = arr[Symbol.iterator]();

console.log(iter.next()); // { done: false, value: 'foo' }

// Insert value in the middle of array
arr.splice(1, 0, 'bar');

console.log(iter.next()); // { done: false, value: 'bar' }
console.log(iter.next()); // { done: false, value: 'baz' }
console.log(iter.next()); // { done: true, value: undefined }

```

NOTE *An iterator maintains a reference to the iterable object, so be aware that the iterator's existence will prevent garbage collection of the iterable object.*

The term “iterator” can be somewhat nebulous because it refers to a generalized iteration concept, an interface, and formal iterator-type classes. The following example compares an explicit iterator implementation and a native iterator implementation:

```
// This class implements the Iterable interface.
// Invoking the default iterator factory will return
// an iterator object that implements the Iterator interface.
class Foo {
  [Symbol.iterator]() {
    return {
      next() {
        return { done: false, value: 'foo' };
      }
    }
  }
}
let f = new Foo();

// Logs an object which implements the Iterator interface
console.log(f[Symbol.iterator]()); // { next: f() {} }

// The Array type implements the Iterable interface.
// Invoking the default iterator of an Array type
// will create an instance of ArrayIterator.
let a = new Array();

// Logs an instance of ArrayIterator
console.log(a[Symbol.iterator]()); // Array Iterator {}
```

Custom Iterator Definition

Like the `Iterable` interface, any object that implements the `Iterator` interface can be used as an iterator. Consider the following example where a `Counter` class is defined to iterate a specific number of times:

```
class Counter {
  // Counter instance should iterate <limit> times
  constructor(limit) {
    this.count = 1;
    this.limit = limit;
  }

  next() {
    if (this.count <= this.limit) {
      return { done: false, value: this.count++ };
    } else {
      return { done: true, value: undefined };
    }
  }
}
```

```
    [Symbol.iterator]() {
      return this;
    }
  }

  let counter = new Counter(3);

  for (let i of counter) {
    console.log(i);
  }
  // 1
  // 2
  // 3
```

This satisfies the `Iterator` interface, but this implementation isn't optimal because each class instance can be iterated only once:

```
for (let i of counter) { console.log(i); }
// 1
// 2
// 3

for (let i of counter) { console.log(i); }
// (nothing logged)
```

In order to allow for creating multiple iterators from a single iterable, the counter must be created on a per-iterator basis. To address this, you can return an iterator object with the counter variables available through a closure:

```
class Counter {
  constructor(limit) {
    this.limit = limit;
  }

  [Symbol.iterator]() {
    let count = 1,
        limit = this.limit;
    return {
      next() {
        if (count <= limit) {
          return { done: false, value: count++ };
        } else {
          return { done: true, value: undefined };
        }
      }
    };
  }
}

let counter = new Counter(3);

for (let i of counter) { console.log(i); }
// 1
// 2
// 3
```

```

for (let i of counter) { console.log(i); }
// 1
// 2
// 3

```

Every iterator created in this way also implements the `Iterable` interface. The `Symbol.iterator` property refers to a factory that will return the same iterator:

```

let arr = ['foo', 'bar', 'baz'];
let iter1 = arr[Symbol.iterator]();

console.log(iter1[Symbol.iterator]); // f values() { [native code] }

let iter2 = iter1[Symbol.iterator]();

console.log(iter1 === iter2); // true

```

Because every iterator also implements the `Iterable` interface, they can be used everywhere an iterable is expected, such as a `for...of` loop:

```

let arr = [3, 1, 4];
let iter = arr[Symbol.iterator]();

for (let item of arr) { console.log(item); }
// 3
// 1
// 4

for (let item of iter) { console.log(item); }
// 3
// 1
// 4

```

Early Termination of Iterators

The optional `return()` method allows for specifying behavior that will execute only if the iterator is closed prematurely. “Closing” an iterator occurs when the construct performing the iteration wishes to indicate to the iterator that it does not intend to finish traversing until exhaustion. Scenarios where this might happen include the following:

- A `for...of` loop exits early via `break`, `continue`, `return`, or `throw`.
- A destructuring operation does not consume all values.

The `return()` method must return a valid `IteratorResult` object. A simple iterator implementation should just return `{ done: true }`, as the return value is only used in the context of generators, which I discuss later in the chapter.

As shown in the code that follows, a built-in language construct will automatically invoke the `return()` method once it identifies that there are further values that need to be iterated over that will not be consumed.

```

class Counter {
  constructor(limit) {

```

```
    this.limit = limit;
  }

  [Symbol.iterator]() {
    let count = 1,
        limit = this.limit;
    return {
      next() {
        if (count <= limit) {
          return { done: false, value: count++ };
        } else {
          return { done: true };
        }
      },
      return() {
        console.log('Exiting early');
        return { done: true };
      }
    };
  }
}
```

```
let counter1 = new Counter(5);
```

```
for (let i of counter1) {
  if (i > 2) {
    break;
  }
  console.log(i);
}
// 1
// 2
// Exiting early
```

```
let counter2 = new Counter(5);
```

```
try {
  for (let i of counter2 {
    if (i > 2) {
      throw 'err';
    }
    console.log(i);
  }
} catch(e) {}
// 1
// 2
// Exiting early
```

```
let counter3 = new Counter(5);
```

```
let [a, b] = counter3;
// Exiting early
```

If an iterator is not closed, then you are able to pick up iteration where you left off. For example, Array Iterators are not closable:

```
let a = [1, 2, 3, 4, 5];
let iter = a[Symbol.iterator]();

for (let i of iter) {
  console.log(i);
  if (i > 2) {
    break
  }
}
// 1
// 2
// 3

for (let i of iter) {
  console.log(i);
}
// 4
// 5
```

Because the `return()` method is optional, not all iterators are closable. Whether or not an iterator is closable can be ascertained by testing if the `return` property on the iterator instance is a function object. However, merely adding the method to a non-closable iterator will *not* make it become closable, as invoking `return()` does not force the iterator into a closed state. The `return()` method will, however, still be invoked:

```
let a = [1, 2, 3, 4, 5];
let iter = a[Symbol.iterator]();

iter.return = function() {
  console.log('Exiting early');
  return { done: true };
};

for (let i of iter) {
  console.log(i);
  if (i > 2) {
    break
  }
}
// 1
// 2
// 3
// Exiting early

for (let i of iter) {
  console.log(i);
}
// 4
// 5
```

GENERATORS

Generators are a delightfully flexible construct introduced in the ECMAScript 6 specification that offers the ability to pause and resume code execution inside a single function block. The implications of this new ability are profound; it allows for, among many other things, the ability to define custom iterators and implement coroutines.

Generator Basics

Generators take the form of a function, and the generator designation is performed with an asterisk. Anywhere a function definition is valid, a generator function definition is also valid:

```
// Generator function declaration
function* generatorFn() {}

// Generator function expression
let generatorFn = function* () {}

// Object literal method generator function
let foo = {
  * generatorFn() {}
}

// Class instance method generator function
class Foo {
  * generatorFn() {}
}

// Class static method generator function
class Bar {
  static * generatorFn() {}
}
```

NOTE *Arrow functions cannot be used as generator functions.*

The function will be considered a generator irrespective of the whitespace surrounding the asterisk:

```
// Equivalent generator functions:
function* generatorFnA() {}
function *generatorFnB() {}
function * generatorFnC() {}

// Equivalent generator methods:
class Foo {
  *generatorFnD() {}
  * generatorFnE() {}
}
```

When invoked, generator functions produce a *generator object*. Generator objects begin in a state of suspended execution. Like iterators, these generator objects implement the `Iterator` interface and therefore feature a `next()` method, which, when invoked, instructs the generator to begin or resume execution.

```
function* generatorFn() {}

const g = generatorFn();

console.log(g);          // generatorFn {<suspended>}
console.log(g.next());  // f next() { [native code] }
```

The return value of this `next()` method matches that of an iterator, with a `done` and `value` property. A generator function with an empty function body will act as a passthrough; invoking `next()` a single time will result in the generator reaching the `done:true` state.

```
function* generatorFn() {}

let generatorObject = generatorFn();

console.log(generatorObject);          // generatorFn {<suspended>}
console.log(generatorObject.next());  // { done: true, value: undefined }
```

The `value` property is the return value of the generator function, which defaults to `undefined` and can be specified via the generator function's return value.

```
function* generatorFn() {
  return 'foo';
}

let generatorObject = generatorFn();

console.log(generatorObject);          // generatorFn {<suspended>}
console.log(generatorObject.next());  // { done: true, value: 'foo' }
```

Generator function execution will only begin upon the initial `next()` invocation, as shown here:

```
function* generatorFn() {
  console.log('foobar');
}

// Nothing is logged yet when the generator function is initially invoked
let generatorObject = generatorFn();

generatorObject.next(); // foobar
```

Generator objects implement the `Iterable` interface, and their default iterator is self-referential:

```
function* generatorFn() {}

console.log(generatorFn);
// f* generatorFn() {}
console.log(generatorFn() [Symbol.iterator]);
// f [Symbol.iterator]() {native code}
```

```
console.log(generatorFn());  
// generatorFn {<suspended>}  
console.log(generatorFn()[Symbol.iterator]());  
// generatorFn {<suspended>}  
  
const g = generatorFn();  
  
console.log(g === g[Symbol.iterator]());  
// true
```

Interrupting Execution with “yield”

The `yield` keyword allows generators to stop and start execution, and it is what makes generators truly useful. Generator functions will proceed with normal execution until they encounter a `yield` keyword. Upon encountering the keyword, execution will be halted and the scope state of the function will be preserved. Execution will only resume when the `next()` method is invoked on the generator object:

```
function* generatorFn() {  
  yield;  
}  
  
let generatorObject = generatorFn();  
  
console.log(generatorObject.next()); // { done: false, value: undefined }  
console.log(generatorObject.next()); // { done: true, value: undefined }
```

The `yield` keyword behaves as an intermediate function return, and the yielded value is available inside the object returned by the `next()` method. A generator function exiting via the `yield` keyword will have a `done` value of `false`; a generator function exiting via the `return` keyword will have a `done` value of `true`:

```
function* generatorFn() {  
  yield 'foo';  
  yield 'bar';  
  return 'baz';  
}  
  
let generatorObject = generatorFn();  
  
console.log(generatorObject.next()); // { done: false, value: 'foo' }  
console.log(generatorObject.next()); // { done: false, value: 'bar' }  
console.log(generatorObject.next()); // { done: true, value: 'baz' }
```

Execution progress within a generator function is scoped to each generator object instance. Invoking `next()` on one generator object does not affect any other:

```
function* generatorFn() {  
  yield 'foo';  
  yield 'bar';  
  return 'baz';  
}
```

```

let generatorObject1 = generatorFn();
let generatorObject2 = generatorFn();

console.log(generatorObject1.next()); // { done: false, value: 'foo' }
console.log(generatorObject2.next()); // { done: false, value: 'foo' }
console.log(generatorObject2.next()); // { done: false, value: 'bar' }
console.log(generatorObject1.next()); // { done: false, value: 'bar' }

```

The `yield` keyword can only be used inside a generator function; anywhere else will throw an error. Like the function `return` keyword, the `yield` keyword must appear immediately inside a generator function definition. Nesting further inside a non-generator function will throw a syntax error:

```

// valid
function* validGeneratorFn() {
  yield;
}

// invalid
function* invalidGeneratorFnA() {
  function a() {
    yield;
  }
}

// invalid
function* invalidGeneratorFnB() {
  const b = () => {
    yield;
  }
}

// invalid
function* invalidGeneratorFnC() {
  (() => {
    yield;
  })();
}

```

Using a Generator Object as an Iterable

You will infrequently find the need to explicitly invoke `next()` on a generator object. Instead, generators are much more useful when consumed as an iterable, as shown here:

```

function* generatorFn() {
  yield 1;
  yield 2;
  yield 3;
}

for (const x of generatorFn()) {
  console.log(x);
}

```

```
// 1
// 2
// 3
```

This can be especially useful when the need to define custom iterables arises. For example, it is often useful to define an iterable, which will produce an iterator that executes a specific number of times. With a generator, this can be accomplished simply with a loop:

```
function* nTimes(n) {
  while(n--) {
    yield;
  }
}

for (let _ of nTimes(3)) {
  console.log('foo');
}
// foo
// foo
// foo
```

The single generator function parameter controls the number of loop iterations. When `n` reaches 0, the `while` condition will become falsy, the loop will exit, and the generator function will return.

Using “yield” for Input and Output

The `yield` keyword also behaves as an intermediate function parameter. The `yield` keyword where the generator last paused execution will assume the first value passed to `next()`. Somewhat confusingly, the value provided to the first `next()` invocation is not used, as this `next()` is used to begin the generator function execution:

```
function* generatorFn(initial) {
  console.log(initial);
  console.log(yield);
  console.log(yield);
}

let generatorObject = generatorFn('foo');

generatorObject.next('bar'); // foo
generatorObject.next('baz'); // baz
generatorObject.next('qux'); // qux
```

The `yield` keyword can be simultaneously used as both an input and an output, as is shown in the following example:

```
function* generatorFn() {
  return yield 'foo';
}

let generatorObject = generatorFn();

console.log(generatorObject.next()); // { done: false, value: 'foo' }
console.log(generatorObject.next('bar')); // { done: true, value: 'bar' }
```

Because the function must evaluate the entire expression to determine the value to return, it will pause execution when encountering the `yield` keyword and evaluate the value to yield, `foo`. The subsequent `next()` invocation provides the `foo` value as the value for that same `yield`, and this in turn is evaluated as the generator function return value.

The `yield` keyword is not limited to a one-time use. An infinite counting generator function can be defined as follows:

```
function* generatorFn() {
  for (let i = 0; ; ++i) {
    yield i;
  }
}

let generatorObject = generatorFn();

console.log(generatorObject.next().value); // 0
console.log(generatorObject.next().value); // 1
console.log(generatorObject.next().value); // 2
console.log(generatorObject.next().value); // 3
console.log(generatorObject.next().value); // 4
console.log(generatorObject.next().value); // 5
...
```

Suppose you wanted to define a generator function that would iterate a configurable number of times and produce the index of iteration. This can be accomplished by instantiating a new array, but the same behavior can be accomplished without the array:

```
function* nTimes(n) {
  for (let i = 0; i < n; ++i) {
    yield i;
  }
}

for (let x of nTimes(3)) {
  console.log(x);
}
// 0
// 1
// 2
```

Alternately, the following has a slightly less verbose `while` loop implementation:

```
function* nTimes(n) {
  let i = 0;
  while(n--) {
    yield i++;
  }
}

for (let x of nTimes(3)) {
  console.log(x);
}
// 0
// 1
// 2
```

Using generators in this way provides a useful way of implementing ranges or populating arrays:

```
function* range(start, end) {
  let i = start;
  while(end > start) {
    yield start++;
  }
}

for (const x of range(4, 7)) {
  console.log(x);
}
// 4
// 5
// 6

function* zeroes(n) {
  while(n--) {
    yield 0;
  }
}

console.log(Array.from(zeroes(8))); // [0, 0, 0, 0, 0, 0, 0, 0]
```

Yielding an Iterable

It is possible to augment the behavior of `yield` to cause it to iterate through an iterable and yield its contents one at a time. This can be done using an asterisk, as shown here:

```
// generatorFn is equivalent to:
// function* generatorFn() {
//   for (const x of [1, 2, 3]) {
//     yield x;
//   }
// }
function* generatorFn() {
  yield* [1, 2, 3];
}

let generatorObject = generatorFn();

for (const x of generatorFn()) {
  console.log(x);
}
// 1
// 2
// 3
```

Like the generator function asterisk, whitespace around the `yield` asterisk will not alter its behavior:

```
function* generatorFn() {
  yield* [1, 2];
  yield * [3, 4];
  yield * [5, 6];
}
```

```

for (const x of generatorFn()) {
  console.log(x);
}
// 1
// 2
// 3
// 4
// 5
// 6

```

Because `yield*` is effectively just serializing an iterable into sequential yielded values, using it isn't any different than placing `yield` inside a loop. These two generator functions are equivalent in behavior:

```

function* generatorFnA() {
  for (const x of [1, 2, 3]) {
    yield x;
  }
}

for (const x of generatorFnA()) {
  console.log(x);
}
// 1
// 2
// 3

function* generatorFnB() {
  yield* [1, 2, 3];
}

for (const x of generatorFnB()) {
  console.log(x);
}
// 1
// 2
// 3

```

The value of `yield*` is the value property accompanying `done:true` of the associated iterator. For vanilla iterators, this value will be `undefined`:

```

function* generatorFn() {
  console.log('iter value:', yield* [1, 2, 3]);
}

for (const x of generatorFn()) {
  console.log('value:', x);
}
// value: 1
// value: 2
// value: 3
// iter value: undefined

```

For iterators produced from a generator function, this value will take the form of whatever value is returned from the generator function:

```

function* innerGeneratorFn() {
  yield 'foo';
}

```



```
    return 'bar';
  }
  function* outerGeneratorFn(genObj) {
    console.log('iter value:', yield* innerGeneratorFn());
  }

  for (const x of outerGeneratorFn()) {
    console.log('value:', x);
  }
  // value: foo
  // iter value: bar
```

Recursive Algorithms Using yield*

`yield*` is most useful when used in a recursive operation, where the generator can yield itself. Consider the following example:

```
function* nTimes(n) {
  if (n > 0) {
    yield* nTimes(n - 1);
    yield n - 1;
  }
}

for (const x of nTimes(3)) {
  console.log(x);
}
// 0
// 1
// 2
```

In this example, each generator is first yielding each value from a newly created generator object, and then yielding a single integer. The result of this is that the generator function will recursively decrement the counter value and instantiate another generator object, which at the top level will have the effect of creating a single iterable that returns incremental integers.

Using recursive generator structure and `yield*` allows for elegantly expressing recursive algorithms. Consider the following graph implementation, which generates a random bidirectional graph:

```
class Node {
  constructor(id) {
    this.id = id;
    this.neighbors = new Set();
  }

  connect(node) {
    if (node !== this) {
      this.neighbors.add(node);
      node.neighbors.add(this);
    }
  }
}

class RandomGraph {
  constructor(size) {
```

```

    this.nodes = new Set();

    // Create nodes
    for (let i = 0; i < size; ++i) {
        this.nodes.add(new Node(i));
    }

    // Randomly connect nodes
    const threshold = 1 / size;
    for (const x of this.nodes) {
        for (const y of this.nodes) {
            if (Math.random() < threshold) {
                x.connect(y);
            }
        }
    }
}

// This is just for debug purposes
print() {
    for (const node of this.nodes) {
        const ids = [...node.neighbors]
            .map((n) => n.id)
            .join(', ');

        console.log(`${node.id}: ${ids}`);
    }
}

const g = new RandomGraph(6);

g.print();
// Example output:
// 0: 2,3,5
// 1: 2,3,4,5
// 2: 1,3
// 3: 0,1,2,4
// 4: 2,3
// 5: 0,4

```

The graph data structure is well-suited for recursive traversal, and using a recursive generator allows you to do exactly that. To do so, the generator function must accept an iterable, yield each value in that iterable, and recurse on each value. A simple utilization of this would be to test if a graph is connected, meaning that there are no nodes that cannot be reached. This test can be accomplished by beginning at one node and exhaustively attempting to visit every node. The result is a very succinct implementation of a depth first traversal:

```

class Node {
    constructor(id) {
        ...
    }

    connect(node) {
        ...
    }
}

```

```
    }  
  }  
  
  class RandomGraph {  
    constructor(size) {  
      ...  
    }  
  
    print() {  
      ...  
    }  
  
    isConnected() {  
      const visitedNodes = new Set();  
  
      function* traverse(nodes) {  
        for (const node of nodes) {  
          if (!visitedNodes.has(node)) {  
            yield node;  
            yield* traverse(node.neighbors);  
          }  
        }  
      }  
    }  
  
    // Grab first node in the Set  
    const firstNode = this.nodes[Symbol.iterator]() .next().value;  
  
    // Use the recursive generator to iterate every node  
    for (const node of traverse([firstNode])) {  
      visitedNodes.add(node);  
    }  
  
    return visitedNodes.size === this.nodes.size;  
  }  
}
```

Using a Generator as the Default Iterator

Because generator objects implement the `Iterable` interface, and because both generator functions and the default iterator are invoked to produce an iterator, generators are exceptionally well suited to be used as default iterators. The following is a simple example where the default iterator can yield the class's contents in a single line:

```
class Foo {  
  constructor() {  
    this.values = [1, 2, 3];  
  }  
  * [Symbol.iterator]() {  
    yield* this.values;  
  }  
}  
  
const f = new Foo();
```

```

for (const x of f) {
  console.log(x);
}
// 1
// 2
// 3

```

Here, the `for...of` loop invokes the default iterator—which happens to be a generator function—and produces a generator object. The generator object is an iterable and therefore compatible for use in iteration.

Early Termination of Generators

Like iterators, generators also support the concept of being “closable.” For an object to implement the `Iterator` interface, it must have a `next()` and, optionally, a `return()` method for when the iterator is terminated early. A generator object has both of these methods and an additional third method, `throw()`.

```

function* generatorFn() {}

const g = generatorFn();

console.log(g);           // generatorFn {<suspended>}
console.log(g.next());   // f next() { [native code] }
console.log(g.return()); // f return() { [native code] }
console.log(g.throw());  // f throw() { [native code] }

```

The `return()` and `throw()` methods are two methods that can be used to coerce the generator into a closed state.

The `return()` Method

The `return()` method will force the generator into a closed state, and the value provided to `return()` will be the value provided in the terminal iterator object:

```

function* generatorFn() {
  for (const x of [1, 2, 3]) {
    yield x;
  }
}

const g = generatorFn();

console.log(g);           // generatorFn {<suspended>}
console.log(g.return(4)); // { done: true, value: 4 }
console.log(g);           // generatorFn {<closed>}

```

Unlike iterators, all generator objects have a `return()` method that forces it into a closed state that it cannot exit once reached. Subsequent invoking of `next()` will disclose the `done:true` state, but any provided return value is not stored or propagated:

```

function* generatorFn() {
  for (const x of [1, 2, 3]) {
    yield x;

```

```
    }  
  }  
  
  const g = generatorFn();  
  
  console.log(g.next()); // { done: false, value: 1 }  
  console.log(g.return(4)); // { done: true, value: 4 }  
  console.log(g.next()); // { done: true, value: undefined }  
  console.log(g.next()); // { done: true, value: undefined }  
  console.log(g.next()); // { done: true, value: undefined }
```

Built-in language constructs such as the `for...of` loop will sensibly ignore any values returned inside the `done:true` `IteratorObject`.

```
function* generatorFn() {  
  for (const x of [1, 2, 3]) {  
    yield x;  
  }  
}  
  
const g = generatorFn();  
  
for (const x of g) {  
  if (x > 1) {  
    g.return(4);  
  }  
  console.log(x);  
}  
// 1  
// 2
```

The `throw()` Method

The `throw()` method will inject a provided error into the generator object at the point it is suspended. If the error is unhandled, the generator will close:

```
function* generatorFn() {  
  for (const x of [1, 2, 3]) {  
    yield x;  
  }  
}  
  
const g = generatorFn();  
  
console.log(g); // generatorFn {<suspended>}  
try {  
  g.throw('foo');  
} catch (e) {  
  console.log(e); // foo  
}  
console.log(g); // generatorFn {<closed>}
```

If, however, the error is handled *inside* the generator function, then it will not close and can resume execution. The error handling will skip over that `yield`, so in this example you will see it skip a value. Consider the following example:

```
function* generatorFn() {
  for (const x of [1, 2, 3]) {
    try {
      yield x;
    } catch(e) {}
  }
}

const g = generatorFn();

console.log(g.next()); // { done: false, value: 1}
g.throw('foo');
console.log(g.next()); // { done: false, value: 3}
```

In this example, the generator suspends execution at a `yield` keyword inside a `try/catch` block. While it is suspended, `throw()` injects the `foo` error, which is thrown by the `yield` keyword. Because this error is thrown inside the generator's `try/catch` block, it is subsequently caught while still inside the generator. However, because `yield` threw that error, that value of 2 will not be produced by the generator. Instead, the generator function continues execution, proceeding on to the next loop iteration where it encounters the `yield` keyword yet again—this time, yielding the value 3.

NOTE *If the generator object has not yet begun execution, calling `throw()` cannot be caught inside the function because the error is thrown from outside the function block.*

SUMMARY

Iteration is a pattern that is encountered in essentially every programming language. The ECMAScript 6 specification formally embraces the concept of iteration by introducing two formal concepts in the language, iterators and generators.

An iterator is an interface that can be implemented by any object and allows for successive visitation of values that it produces. Anything that implements the `Iterable` interface features a `Symbol.iterator` property, which references the default iterator. The default iterator behaves as an iterator factory: a function which, when invoked, produces an object that implements the `Iterator` interface.

Successive values are coerced from an iterator via its `next()` method, which returns an `IteratorObject`. This object contains a `done` property, a Boolean indicating if there are more values available, and a `value` property, which contains the present value provided from the iterator. This interface can be manually consumed by invoking `next()` repeatedly, or automatically consumed by native iterable consumers such as the `for...of` loop.

Generators are a special type of function that, when invoked, produces a generator object. This generator object implements the `Iterable` interface, and therefore can be used anywhere an iterable is expected. Generators are unique in that they support the `yield` keyword, which is used to pause execution of the generator function. The `yield` keyword can also be used to accept input and output through the `next()` method. When accompanied by an asterisk, the `yield` keyword will serve to serialize an iterable it is paired with.

8

Objects, Classes, and Object-Oriented Programming

WHAT'S IN THIS CHAPTER?

- Understanding objects
- Understanding object creation
- Understanding inheritance
- Understanding classes

ECMA-262 defines an object as an unordered collection of properties. Strictly speaking, this means that an object is an array of values in no particular order. Each property or method is identified by a name that is mapped to a value. For this reason (and others yet to be discussed), it helps to think of ECMAScript objects as hash tables: nothing more than a grouping of name-value pairs where the value may be data or a function.

UNDERSTANDING OBJECTS

The canonical way of creating a custom object is to create a new instance of `Object` and add properties and methods to it, as in this example:

```
let person = new Object();
person.name = "Nicholas";
person.age = 29;
person.job = "Software Engineer";
```



```
person.sayName = function() {  
  console.log(this.name);  
};
```

This example creates an object called `person` that has three properties (`name`, `age`, and `job`) and one method (`sayName()`). The `sayName()` method displays the value of `this.name`, which resolves to `person.name`. Early JavaScript developers used this pattern frequently to create new objects. A few years later, object literals became the preferred pattern for creating such objects. The previous example can be rewritten using object literal notation as follows:

```
let person = {  
  name: "Nicholas",  
  age: 29,  
  job: "Software Engineer",  
  sayName() {  
    console.log(this.name);  
  }  
};
```

The `person` object in this example is equivalent to the `person` object in the prior example, with all the same properties and methods. These properties are all created with certain characteristics that define their behavior in JavaScript.

Types of Properties

ECMA-262 describes characteristics of properties through the use of internal-only attributes. These attributes are defined by the specification for implementation in JavaScript engines, and as such, these attributes are not directly accessible in JavaScript. To indicate that an attribute is internal, surround the attribute name with two pairs of square brackets, such as `[[Enumerable]]`.

There are two types of properties: data properties and accessor properties.

Data Properties

Data properties contain a single location for a data value. Values are read from and written to this location. Data properties have four attributes describing their behavior:

- `[[Configurable]]`—Indicates if the property may be redefined by removing the property via `delete`, changing the property's attributes, or changing the property into an accessor property. By default, this is true for all properties defined directly on an object, as in the previous example.
- `[[Enumerable]]`—Indicates if the property will be returned in a `for-in` loop. By default, this is true for all properties defined directly on an object, as in the previous example.
- `[[Writable]]`—Indicates if the property's value can be changed. By default, this is true for all properties defined directly on an object, as in the previous example.
- `[[Value]]`—Contains the actual data value for the property. This is the location from which the property's value is read and the location to which new values are saved. The default value for this attribute is `undefined`.

When a property is explicitly added to an object as in the previous examples, `[[Configurable]]`, `[[Enumerable]]`, and `[[Writable]]` are all set to true while the `[[Value]]` attribute is set to the assigned value. For example:

```
let person = {
  name: "Nicholas"
};
```

Here, the property called `name` is created and a value of `"Nicholas"` is assigned. That means `[[Value]]` is set to `"Nicholas"`, and any changes to that value are stored in this location.

To change any of the default property attributes, you must use the `Object.defineProperty()` method. This method accepts three arguments: the object on which the property should be added or modified, the name of the property, and a descriptor object. The properties on the descriptor object match the attribute names: `configurable`, `enumerable`, `writable`, and `value`. You can set one or all of these values to change the corresponding attribute values. For example:

```
let person = {};
Object.defineProperty(person, "name", {
  writable: false,
  value: "Nicholas"
});
console.log(person.name); // "Nicholas"
person.name = "Greg";
console.log(person.name); // "Nicholas"
```

This example creates a property called `name` with a value of `"Nicholas"` that is read-only. The value of this property can't be changed, and any attempts to assign a new value are ignored in nonstrict mode. In strict mode, an error is thrown when an attempt is made to change the value of a read-only property.

Similar rules apply to creating a nonconfigurable property. For example:

```
let person = {};
Object.defineProperty(person, "name", {
  configurable: false,
  value: "Nicholas"
});
console.log(person.name); // "Nicholas"
delete person.name;
console.log(person.name); // "Nicholas"
```

Here, setting `configurable` to `false` means that the property cannot be removed from the object. Calling `delete` on the property has no effect in nonstrict mode and throws an error in strict mode. Additionally, once a property has been defined as nonconfigurable, it cannot become configurable again. Any attempt to call `Object.defineProperty()` and change any attribute other than `writable` causes an error:

```
let person = {};
Object.defineProperty(person, "name", {
  configurable: false,
  value: "Nicholas"
});
```

```
// Throws an error
Object.defineProperty(person, "name", {
  configurable: true,
  value: "Nicholas"
});
```

So although you can call `Object.defineProperty()` multiple times for the same property, there are limits once `configurable` has been set to `false`.

When you are using `Object.defineProperty()`, the values for `configurable`, `enumerable`, and `writable` default to `false` unless otherwise specified. In most cases, you likely won't need the powerful options provided by `Object.defineProperty()`, but it's important to understand the concepts to have a good understanding of JavaScript objects.

Accessor Properties

Accessor properties do not contain a data value. Instead, they contain a combination of a getter function and a setter function (though both are not necessary). When an accessor property is read from, the getter function is called, and it's the function's responsibility to return a valid value; when an accessor property is written to, a function is called with the new value, and that function must decide how to react to the data. Accessor properties have four attributes:

- `[[Configurable]]`—Indicates if the property may be redefined by removing the property via `delete`, changing the property's attributes, or changing the property into a data property. By default, this is `true` for all properties defined directly on an object.
- `[[Enumerable]]`—Indicates if the property will be returned in a `for-in` loop. By default, this is `true` for all properties defined directly on an object.
- `[[Get]]`—The function to call when the property is read from. The default value is `undefined`.
- `[[Set]]`—The function to call when the property is written to. The default value is `undefined`.

It is not possible to define an accessor property explicitly; you must use `Object.defineProperty()`. Here's a simple example:

```
// Define object with pseudo-private member 'year_'
// and public member 'edition'
let book = {
  year_: 2017,
  edition: 1
};

Object.defineProperty(book, "year", {
  get() {
    return this.year_;
  },
  set(newValue) {
    if (newValue > 2017) {
      this.year_ = newValue;
      this.edition += newValue - 2017;
    }
  }
});
book.year = 2018;
console.log(book.edition); // 2
```

In this code, an object `book` is created with two default properties: `year_` and `edition`. The underscore on `year_` is a common notation to indicate that a property is not intended to be accessed from outside of the object's methods. The `year` property is defined to be an accessor property where the getter function simply returns the value of `year_` and the setter does some calculation to determine the correct edition. So changing the `year` property to 2018 results in both `year_` and `edition` changing to 2. This is a typical use case for accessor properties, when setting a property value results in some other changes to occur.

It's not necessary to assign both a getter and a setter. Assigning just a getter means that the property cannot be written to and attempts to do so will be ignored. In strict mode, trying to write to a property with only a getter throws an error. Likewise, a property with only a setter cannot be read and will return the value `undefined` in nonstrict mode, while doing so throws an error in strict mode.

There is no way to modify `[[Configurable]]` or `[[Enumerable]]` in browsers that don't support `Object.defineProperty()`.

NOTE *Prior to ECMAScript 5, two nonstandard methods were used to create accessor properties: `__defineGetter__()` and `__defineSetter__()`. These were first developed by Firefox and later copied by Safari, Chrome, and Opera.*

Defining Multiple Properties

Because there's a high likelihood that you'll need to define more than one property on an object, ECMAScript provides the `Object.defineProperties()` method. This method allows you to define multiple properties using descriptors at once. There are two arguments: the object on which to add or modify the properties and an object whose property names correspond to the properties' names to add or modify. For example:

```
let book = {};
Object.defineProperties(book, {
  year_: {
    value: 2017
  },

  edition: {
    value: 1
  },

  year: {
    get() {
      return this.year_;
    },

    set(newValue) {
      if (newValue > 2017) {
        this.year_ = newValue;
        this.edition += newValue - 2017;
      }
    }
  }
});
```

This code defines two data properties, `year_` and `edition`, and an accessor property called `year` on the `book` object. The resulting object is identical to the example in the previous section. The only difference is that all of these properties are created at the same time.

Reading Property Attributes

It's also possible to retrieve the property descriptor for a given property by using the `Object.getPrototypeOf()` method. This method accepts two arguments: the object on which the property resides and the name of the property whose descriptor should be retrieved. The return value is an object with properties for `configurable`, `enumerable`, `get`, and `set` for accessor properties or `configurable`, `enumerable`, `writable`, and `value` for data properties. For example:

```
let book = {};
Object.defineProperties(book, {
  year_: {
    value: 2017
  },

  edition: {
    value: 1
  },

  year: {
    get: function() {
      return this.year_;
    },

    set: function(newValue) {
      if (newValue > 2017) {
        this.year_ = newValue;
        this.edition += newValue - 2017;
      }
    }
  }
});

let descriptor = Object.getOwnPropertyDescriptor(book, "year_");
console.log(descriptor.value); // 2017
console.log(descriptor.configurable); // false
console.log(typeof descriptor.get); // "undefined"
let descriptor = Object.getOwnPropertyDescriptor(book, "year");
console.log(descriptor.value); // undefined
console.log(descriptor.enumerable); // false
console.log(typeof descriptor.get); // "function"
```

For the data property `year_`, `value` is equal to the original value, `configurable` is `false`, and `get` is `undefined`. For the accessor property `year`, `value` is `undefined`, `enumerable` is `false`, and `get` is a pointer to the specified getter function.

New in ECMAScript 2017 is the `Object.getOwnPropertyDescriptors()` static method. This method effectively performs on `Object.getOwnPropertyDescriptor()` on all own properties and returns them in a new object. For the previous example, using this static method would return the following object:

```
let book = {};  
Object.defineProperty(book, {  
  year_: {  
    value: 2017  
  },  
  
  edition: {  
    value: 1  
  },  
  
  year: {  
    get: function() {  
      return this.year_;  
    },  
  
    set: function(newValue){  
      if (newValue > 2017) {  
        this.year_ = newValue;  
        this.edition += newValue - 2017;  
      }  
    }  
  }  
});  
  
console.log(Object.getOwnPropertyDescriptors(book));  
// {  
//   edition: {  
//     configurable: false,  
//     enumerable: false,  
//     value: 1,  
//     writable: false  
//   },  
//   year: {  
//     configurable: false,  
//     enumerable: false,  
//     get: f(),  
//     set: f(newValue),  
//   },  
//   year_: {  
//     configurable: false,  
//     enumerable: false,  
//     value: 2019,  
//     writable: false  
//   }  
// }
```

Merging Objects

JavaScript developers will often find that it is useful to be able to perform a “merge” of two objects. More specifically, this merge will take the form of folding all the local properties of one source object into a destination object. Often, this behavior is also referred to as using a “mixin,” in which the destination object is augmented by mixing in the properties of a source object.

ECMAScript 6 introduces this exact behavior with the `Object.assign()` method. This method accepts one destination object, and one or many source objects, and for each source object copies the enumerable (`Object.propertyIsEnumerable` returns `true`) and own (`Object.hasOwnProperty` returns `true`) properties onto the destination object. Properties keyed with strings and symbols will be copied. For each suitable property, the method will use `[[Get]]` to retrieve a value from the source object and `[[Set]]` on the destination object to assign the value.

```
let dest, src, result;

/**
 * Simple copy
 */
dest = {};
src = { id: 'src' };

result = Object.assign(dest, src);

// Object.assign mutates the destination object
// and also returns that object after exiting.
console.log(dest === result); // true
console.log(dest !== src);   // true
console.log(result);         // { id: src }
console.log(dest);           // { id: src }

/**
 * Multiple source objects
 */
dest = {};

result = Object.assign(dest, { a: 'foo' }, { b: 'bar' });

console.log(result); // { a: foo, b: bar }

/**
 * Getters and setters
 */
dest = {
  set a(val) {
    console.log('Invoked dest setter with param ${val}');
  }
};
src = {
  get a() {
    console.log('Invoked src getter');
    return 'foo';
  }
};

Object.assign(dest, src);
// Invoked src getter
// Invoked dest setter with param foo
```

```
// Since the setter does not perform an assignment,
// no value is actually transferred
console.log(dest); // { set a(val) {...} }
```

`Object.assign()` is effectively performing a shallow copy from each source object. If multiple source objects have the same property defined, the last one to be copied will be the ultimate value. Furthermore, any value retrieved from accessor properties, such as a getter, on a source object will be assigned as a static value on the destination object—there is no ability to transfer getters and setters between objects.

```
let dest, src, result;

/**
 * Overwritten properties
 */
dest = { id: 'dest' };

result = Object.assign(dest, { id: 'src1', a: 'foo' }, { id: 'src2', b: 'bar' });

// Object.assign will overwrite duplicate properties.
console.log(result); // { id: src2, a: foo, b: bar }

// This can be observed by using a setter on the destination object:
dest = {
  set id(x) {
    console.log(x);
  }
};

Object.assign(dest, { id: 'first' }, { id: 'second' }, { id: 'third' });
// first
// second
// third

/**
 * Object references
 */

dest = {};
src = { a: {} };

Object.assign(dest, src);

// Shallow property copies means only object references copied.
console.log(dest); // { a :{} }
console.log(dest.a === src.a); // true
```

If an error is thrown during the assignment, it will discontinue and exit with the thrown error. `Object.assign()` has no concept of “rolling back” earlier assignments so it is a best-effort method that may only partially complete.

```
let dest, src, result;

/**
```



```

    * Error handling
    */
    dest = {};
    src = {
      a: 'foo',
      get b() {
        // Error will be thrown when Object.assign()
        // invokes this getter.
        throw new Error();
      },
      c: 'bar'
    };

    try {
      Object.assign(dest, src);
    } catch(e) {}

    // Object.assign() has no way of rolling back already performed changes,
    // so set operations already performed on the destination object before
    // the error is thrown remain:
    console.log(dest); // { a: foo }

```

Object Identity and Equality

In versions prior to ECMAScript 6, there were several tricky corner cases where the `===` operator was insufficient:

```

// These are cases where === behaves as expected:
console.log(true === 1); // false
console.log({} === {}); // false
console.log("2" === 2); // false

// These have different representations in the JS engine and yet are treated as equal
console.log(+0 === -0); // true
console.log(+0 === 0); // true
console.log(-0 === 0); // true

// To determine NaN equivalence, the profoundly annoying isNaN() is required
console.log(NaN === NaN); // false
console.log(isNaN(NaN)); // true

```

To remedy this, the ECMAScript 6 specification introduced `Object.is()`, which behaves mostly as `===` does but also accounts for the corner cases listed previously. The method accepts exactly two arguments:

```

console.log(Object.is(true, 1)); // false
console.log(Object.is({}, {})); // false
console.log(Object.is("2", 2)); // false

// Correct 0, -0, +0 equivalence/nonequivalence:
console.log(Object.is(+0, -0)); // false
console.log(Object.is(+0, 0)); // true
console.log(Object.is(-0, 0)); // false

// Correct NaN equivalence:
console.log(Object.is(NaN, NaN)); // true

```

To check more than two objects, it is trivial to recursively use transitive equality:

```
function recursivelyCheckEqual(x, ...rest) {
  return Object.is(x, rest[0]) &&
    (rest.length < 2 || recursivelyCheckEqual(...rest));
}
```

Enhanced Object Syntax

ECMAScript 6 introduced a handful of extremely useful syntactical tools for defining and interacting with objects. None of them meaningfully change existing engine behavior, but they enormously enhance the convenience of dealing with objects.

All object syntax conventions introduced in this section are also applicable to ECMAScript 6 classes, defined later in this chapter.

NOTE *The enhanced object syntax described in this section is almost universally superior to what it replaces; therefore, you will find that it is used by default here in this chapter as well as elsewhere in the book.*

Property Value Shorthand

Developers frequently find that, when adding a variable to an object, the property name used to key that variable often will match the variable name itself. For example:

```
let name = 'Matt';

let person = {
  name: name
};

console.log(person); // { name: 'Matt' }
```

Thus, the property value shorthand convention was introduced. This allows you to simply use the variable itself without the colon notation, and the interpreter will automatically use the variable name as the property key. If the variable name is not found, a `ReferenceError` will be thrown.

The following code is equivalent:

```
let name = 'Matt';

let person = {
  name
};

console.log(person); // { name: 'Matt' }
```

Minifiers will preserve property names between scopes to prevent breaking references. Take the following code snippet for example:

```
function makePerson(name) {
  return {
```

```
        name
    };
}

let person = makePerson('Matt');

console.log(person.name); // Matt
```

Compilers are careful to preserve the initial name string identifier inside the function definition even though the parameter identifier is restricted to the function scope. When this is compiled using the Google Closure compiler, the function parameter name will be shortened, but the property name will remain:

```
function makePerson(a) {
    return {
        name: a
    };
}

var person = makePerson("Matt");

console.log(person.name); // Matt
```

Computed Property Keys

Prior to the introduction of computed property keys, there was no way to dynamically assign property keys in an object literal without declaring the object and then individually using the square bracket notation for property assignment. For example:

```
const nameKey = 'name';
const ageKey = 'age';
const jobKey = 'job';

let person = {};
person[nameKey] = 'Matt';
person[ageKey] = 27;
person[jobKey] = 'Software engineer';

console.log(person); // { name: 'Matt', age: 27, job: 'Software engineer' }
```

With computed properties, the property assignment can occur inside the object literal's initial definition. Square brackets around the object property key instruct the runtime to evaluate its contents as a JavaScript expression instead of a string:

```
const nameKey = 'name';
const ageKey = 'age';
const jobKey = 'job';

let person = {
    [nameKey]: 'Matt',
    [ageKey]: 27,
    [jobKey]: 'Software engineer'
};

console.log(person); // { name: 'Matt', age: 27, job: 'Software engineer' }
```

Because the contents are evaluated as a JavaScript expression, it is possible to make the contents of the computed property complex expressions to be evaluated upon instantiation:

```
const nameKey = 'name';
const ageKey = 'age';
const jobKey = 'job';
let uniqueToken = 0;

function getUniqueKey(key) {
  return `${key}_${uniqueToken++}`;
}

let person = {
  [getUniqueKey(nameKey)]: 'Matt',
  [getUniqueKey(ageKey)]: 27,
  [getUniqueKey(jobKey)]: 'Software engineer'
};

console.log(person); // { name_0: 'Matt', age_1: 27, job_2: 'Software engineer' }
```

NOTE Any errors thrown in a computed property key expression will abort the creation of the object. Be careful when the expressions computing a property key have side effects, as an error thrown in an expression will not roll back earlier computation.

Concise Method Syntax

When defining function properties of an object, the format almost always takes the form of a property key referencing an anonymous function expression, as follows:

```
let person = {
  sayName: function(name) {
    console.log('My name is ${name}');
  }
};

person.sayName('Matt'); // My name is Matt
```

The new shorthand method syntax follows this pattern and allows the developer to give up the capability to name the function expression—which, most of the time, is not useful anyway—and in exchange dramatically shorten how a function property can be expressed.

The following is behaviorally identical to the previous code snippet:

```
let person = {
  sayName(name) {
    console.log('My name is ${name}');
  }
};

person.sayName('Matt'); // My name is Matt
```

This is also applicable to the getter and setter object conventions:

```
let person = {
  name_: '',
  get name() {
    return this.name_;
  },
  set name(name) {
    this.name_ = name;
  },
  sayName() {
    console.log('My name is ${this.name_}');
  }
};

person.name = 'Matt';
person.sayName(); // My name is Matt
```

Shorthand method syntax and computed property keys are mutually compatible:

```
const methodKey = 'sayName';

let person = {
  [methodKey](name) {
    console.log('My name is ${name}');
  }
}

person.sayName('Matt'); // My name is Matt
```

NOTE *You will find that the shorthand method syntax is more useful in the context of ECMAScript 6 classes, which are covered later in the chapter.*

Object Destructuring

ECMAScript 6 introduced object destructuring, which allows you to perform one or many operations using nested data within a single statement. With respect to objects, this gives you the ability to perform assignments from object properties using syntax that matches the structure of an object.

The following is an example of two equivalent code snippets, first without object destructuring:

```
// Without object destructuring
let person = {
  name: 'Matt',
  age: 27
};

let personName = person.name,
    personAge = person.age;

console.log(personName); // Matt
console.log(personAge); // 27
```

Second, using object destructuring:

```
// With object destructuring
let person = {
  name: 'Matt',
  age: 27
};

let { name: personName, age: personAge } = person;

console.log(personName); // Matt
console.log(personAge); // 27
```

Destructuring allows you to declare multiple variables and simultaneously perform multiple assignments all inside a single object literal-like syntax. If you want to reuse the property name as a local variable name, you can use a shorthand syntax, as follows:

```
let person = {
  name: 'Matt',
  age: 27
};

let { name, age } = person;

console.log(name); // Matt
console.log(age); // 27
```

Destructuring assignments do not have to match what is inside the object. You are able to ignore properties when performing an assignment; conversely, if you reference a property that does not exist, `undefined` will be assigned:

```
let person = {
  name: 'Matt',
  age: 27
};

let { name, job } = person;

console.log(name); // Matt
console.log(job); // undefined
```

It is also possible to define default values, which will be applied in the event that a property does not exist in the source object:

```
let person = {
  name: 'Matt',
  age: 27
};

let { name, job='Software engineer' } = person;

console.log(name); // Matt
console.log(job); // Software engineer
```

Destructuring uses the internal function `ToObject()` (which is not directly accessible in the runtime) to coerce a source into an object. This means that primitive values will be treated as objects when

used in a destructuring operation; this also means that, by definition in the `ToObject()` specification, `null` and `undefined` cannot be destructured and will throw an error.

```
let { length } = 'foobar';
console.log(length);      // 6

let { constructor: c } = 4;
console.log(c === Number); // true

let { _ } = null;        // TypeError

let { _ } = undefined;  // TypeError
```

Destructuring does not demand that variable declarations occur inside the destructuring expression. However, doing so requires the assignment expression to be contained inside parentheses:

```
let personName, personAge;

let person = {
  name: 'Matt',
  age: 27
};

({name: personName, age: personAge} = person);

console.log(personName, personAge); // Matt, 27
```

Nested Destructuring

There are no restrictions on referencing nested properties or assignment targets. This allows you to do things like perform copies of object properties:

```
let person = {
  name: 'Matt',
  age: 27,
  job: {
    title: 'Software engineer'
  }
};
let personCopy = {};

({
  name: personCopy.name,
  age: personCopy.age,
  job: personCopy.job
} = person);

// Because an object reference was assigned into personCopy, changing a property
// inside the person.job object will be propagated to personCopy:
person.job.title = 'Hacker'

console.log(person);
// { name: 'Matt', age: 27, job: { title: 'Hacker' } }

console.log(personCopy);
```

```
// { name: 'Matt', age: 27, job: { title: 'Hacker' } }
```

Destructuring assignments can be nested to match nested property references:

```
let person = {
  name: 'Matt',
  age: 27,
  job: {
    title: 'Software engineer'
  }
};

// Declares 'title' variable and assigns person.job.title as its value
let { job: { title } } = person;

console.log(title); // Software engineer
```

You cannot use nested property references when an outer property is undefined. This is true for both source objects and destination objects:

```
let person = {
  job: {
    title: 'Software engineer'
  }
};
let personCopy = {};

// 'foo' is undefined on the source object
({
  foo: {
    bar: personCopy.bar
  }
} = person);
// TypeError: Cannot destructure property 'bar' of 'undefined' or 'null'.

// 'job' is undefined on the destination object
({
  job: {
    title: personCopy.job.title
  }
} = person);
// TypeError: Cannot set property 'title' of undefined
```

Partial Destructuring Completion

It's important to note that a destructured assignment involving multiple properties is a sequential operation with independent outcomes. If, within a single destructured expression with multiple assignments, the initial assignments succeed but a later one throws an error, the destructured assignment will exit having only partially completed:

```
let person = {
  name: 'Matt',
  age: 27
};

let personName, personBar, personAge;
```



```
try {
  // person.foo is undefined, so this will throw an error
  ({name: personName, foo: { bar: personBar }, age: personAge} = person);
} catch(e) {}

console.log(personName, personBar, personAge);
// Matt, undefined, undefined
```

Parameter Context Matching

It is also possible to perform a destructured assignment inside a function parameter list. It does not affect the arguments object, but it allows you to declare variables inside the function signature that are immediately available inside the function body:

```
let person = {
  name: 'Matt',
  age: 27
};

function printPerson(foo, {name, age}, bar) {
  console.log(arguments);
  console.log(name, age);
}

function printPerson2(foo, {name: personName, age: personAge}, bar) {
  console.log(arguments);
  console.log(personName, personAge);
}

printPerson('1st', person, '2nd');
// ['1st', { name: 'Matt', age: 27 }, '2nd']
// 'Matt', 27

printPerson2('1st', person, '2nd');
// ['1st', { name: 'Matt', age: 27 }, '2nd']
// 'Matt', 27
```

OBJECT CREATION

Although using the `Object` constructor or an object literal are convenient ways to create single objects, there is an obvious downside: Creating multiple objects with the same interface requires a lot of code duplication.

Overview

Through successive specifications, the available features of ECMAScript followed a highly unusual pattern. Through the ECMAScript 5.1 specification, there was no formal support for object-oriented constructs such as classes or inheritance. However, as you will see in the following sections, clever application of prototypal inheritance allowed JavaScript developers to emulate this behavior—quite successfully.

With the ECMAScript 6 specification, formal support for classes and inheritance was introduced. These ES6 classes are intended to completely subsume the prototype-based class solutions designed in previous specifications. However, their implementation is, in many ways, merely a syntactical abstraction for ES5.1-style constructor functions and prototypal inheritance.

NOTE *Make no mistake: A JavaScript codebase built upon object-oriented patterns should almost always use ECMAScript 6 classes. That said, it is instructive to learn about the conventions that existed prior to ES6 classes, especially since the ES6 class definition can be imagined as a thin wrapper around existing constructs. Therefore, before the ES6 classes section, the following sections will progressively introduce the underlying concepts that are replaced by classes.*

The Factory Pattern

The factory pattern is a well-known design pattern used in software engineering to abstract away the process of creating specific objects. (Other design patterns and their implementation in JavaScript are discussed later in the book.) One way to create objects with specific interfaces is shown in this example:

```
function createPerson(name, age, job) {
  let o = new Object();
  o.name = name;
  o.age = age;
  o.job = job;
  o.sayName = function() {
    console.log(this.name);
  };
  return o;
}

let person1 = createPerson("Nicholas", 29, "Software Engineer");
let person2 = createPerson("Greg", 27, "Doctor");
```

Here, the function `createPerson()` accepts arguments with which to build an object with all of the necessary information to represent a `Person` object. The function can be called any number of times with different arguments and will still return an object that has three properties and one method. Though this solved the problem of creating multiple similar objects, the factory pattern didn't address the issue of object identification (what type of object an object is).

The Function Constructor Pattern

As mentioned in previous chapters, constructors in ECMAScript are used to create specific types of objects. There are native constructors, such as `Object` and `Array`, which are available automatically in the execution environment at runtime. It is also possible to define custom constructors, in the form of a function, that define properties and methods for your own type of object.

For instance, the previous example can be rewritten using the function constructor pattern:

```
function Person(name, age, job){
  this.name = name;
  this.age = age;
  this.job = job;
  this.sayName = function() {
    console.log(this.name);
  };
}

let person1 = new Person("Nicholas", 29, "Software Engineer");
let person2 = new Person("Greg", 27, "Doctor");

person1.sayName(); // Nicholas
person2.sayName(); // Greg
```

In this example, the `Person()` function takes the place of the factory `createPerson()` function. Note that the code inside `Person()` is the same as the code inside `createPerson()`, with the following exceptions:

- There is no object being created explicitly.
- The properties and method are assigned directly onto the `this` object.
- There is no `return` statement.

Also note the name of the function is `Person` with an uppercase *P*. By convention, constructor functions always begin with an uppercase letter, whereas nonconstructor functions begin with a lowercase letter. This convention is borrowed from other OO languages and helps to distinguish function use in ECMAScript because constructors are simply functions that create objects.

To create a new instance of `Person`, use the `new` operator. Calling a constructor in this manner will do the following:

1. A new object is created in memory.
2. The new object's internal `[[Prototype]]` pointer is assigned to the constructor's `prototype` property.
3. The `this` value of the constructor is assigned to the new object (so `this` points to the new object).
4. The code inside the constructor is executed (adds properties to the new object).
5. If the constructor function returns a non-null value, that object is returned. Otherwise, the new object that was just created is returned.

At the end of the preceding example, `person1` and `person2` are each filled with a different instance of `Person`. Each of these objects has a `constructor` property that points back to `Person`, as follows:

```
console.log(person1.constructor == Person); // true
console.log(person2.constructor == Person); // true
```

The `constructor` property was originally intended for use in identifying the object type. However, the `instanceof` operator is considered to be a safer way of determining type. Each of the objects in this example is considered to be both an instance of `Object` and an instance of `Person`, as indicated by using the `instanceof` operator like this:

```
console.log(person1 instanceof Object); // true
console.log(person1 instanceof Person); // true
console.log(person2 instanceof Object); // true
console.log(person2 instanceof Person); // true
```

Defining your own constructors ensures that instances can be identified as a particular type later on, which is a great advantage over the factory pattern. In this example, `person1` and `person2` are considered to be instances of `Object` because all custom objects inherit from `Object` (the specifics of this are discussed later).

Constructor functions do not have to be expressed as a function declaration. A function expression assigned to a variable behaves identically:

```
let Person = function(name, age, job) {
  this.name = name;
  this.age = age;
  this.job = job;
  this.sayName = function() {
    console.log(this.name);
  };
};

let person1 = new Person("Nicholas", 29, "Software Engineer");
let person2 = new Person("Greg", 27, "Doctor");

person1.sayName(); // Nicholas
person2.sayName(); // Greg

console.log(person1 instanceof Object); // true
console.log(person1 instanceof Person); // true
console.log(person2 instanceof Object); // true
console.log(person2 instanceof Person); // true
```

When instantiating, the parentheses after the constructor function are optional if you do not wish to pass any arguments—the `new` operator will invoke the constructor function no matter what:

```
function Person() {
  this.name = "Jake";
  this.sayName = function() {
    console.log(this.name);
  };
};

let person1 = new Person();
let person2 = new Person;

person1.sayName(); // Jake
person2.sayName(); // Jake

console.log(person1 instanceof Object); // true
```

```
console.log(person1 instanceof Person); // true
console.log(person2 instanceof Object); // true
console.log(person2 instanceof Person); // true
```

Constructors as Functions

The only difference between constructor functions and other functions is the way in which they are called. Constructors are, after all, just functions; there's no special syntax to define a constructor that automatically makes it behave as such. Any function that is called with the `new` operator acts as a constructor, whereas any function called without it acts just as you would expect a normal function call to act. For instance, the `Person()` function from the previous example may be called in any of the following ways:

```
// use as a constructor
let person = new Person("Nicholas", 29, "Software Engineer");
person.sayName(); // "Nicholas"

// call as a function
Person("Greg", 27, "Doctor"); // adds to window
window.sayName(); // "Greg"

// call in the scope of another object
let o = new Object();
Person.call(o, "Kristen", 25, "Nurse");
o.sayName(); // "Kristen"
```

The first part of this example shows the typical use of a constructor—to create a new object via the `new` operator. The second part shows what happens when the `Person()` function is called without the `new` operator: The properties and methods get added to the `window` object. Remember that the `this` object always points to the `Global` object (`window` in web browsers) when a function is called without an explicitly set `this` value (by being an object method or through `call()/apply()`). So after the function is called, the `sayName()` method can be called on the `window` object, and it will return "Greg". The `Person()` function can also be called within the scope of a particular object using `call()` (or `apply()`). In this case, it's called with a `this` value of the object `o`, which then gets assigned all of the properties and the `sayName()` method.

Problems with Constructors

Though the constructor paradigm is useful, it is not without its faults. The major downside to constructors is that methods are created once for each instance. So, in the previous example, both `person1` and `person2` have a method called `sayName()`, but those methods are not the same instance of `Function`. Remember that functions are objects in ECMAScript, so every time a function is defined, it's actually an object being instantiated. Logically, the constructor actually looks like this:

```
function Person(name, age, job){
  this.name = name;
  this.age = age;
  this.job = job;
  this.sayName = new Function("console.log(this.name)"); // logical equivalent
}
```

Thinking about the constructor in this manner makes it clear that each instance of `Person` gets its own instance of `Function` that happens to display the `name` property. To be clear, creating a function

in this manner is different with regard to scope chains and identifier resolution, but the mechanics of creating a new instance of `Function` remain the same. So, functions of the same name on different instances are not equivalent, as the following code proves:

```
console.log(person1.sayName == person2.sayName); // false
```

It doesn't make sense to have two instances of `Function` that do the same thing, especially when the `this` object makes it possible to avoid binding functions to particular objects until runtime.

It's possible to work around this limitation by moving the function definition outside of the constructor, as follows:

```
function Person(name, age, job){
  this.name = name;
  this.age = age;
  this.job = job;
  this.sayName = sayName;
}

function sayName() {
  console.log(this.name);
}

let person1 = new Person("Nicholas", 29, "Software Engineer");
let person2 = new Person("Greg", 27, "Doctor");

person1.sayName(); // Nicholas
person2.sayName(); // Greg
```

In this example, the `sayName()` function is defined outside the constructor. Inside the constructor, the `sayName` property is set equal to the global `sayName()` function. Because the `sayName` property now contains just a pointer to a function, both `person1` and `person2` end up sharing the `sayName()` function that is defined in the global scope. This solves the problem of having duplicate functions that do the same thing but also creates some clutter in the global scope by introducing a function that can realistically be used only in relation to an object. If the object needed multiple methods, that would mean multiple global functions, and all of a sudden the custom reference type definition is no longer nicely grouped in the code. These problems are addressed by using the prototype pattern.

The Prototype Pattern

Each function is created with a `prototype` property, which is an object containing properties and methods that should be available to instances of a particular reference type. This object is literally a prototype for the object to be created once the constructor is called. The benefit of using the prototype is that all of its properties and methods are shared among object instances. Instead of assigning object information in the constructor, they can be assigned directly to the prototype, as in this example:

```
function Person() {}

Person.prototype.name = "Nicholas";
Person.prototype.age = 29;
Person.prototype.job = "Software Engineer";
```

```
Person.prototype.sayName = function() {
  console.log(this.name);
};

let person1 = new Person();
person1.sayName(); // "Nicholas"

let person2 = new Person();
person2.sayName(); // "Nicholas"

console.log(person1.sayName == person2.sayName); // true
```

Using a function expression is also suitable:

```
let Person = function() {};

Person.prototype.name = "Nicholas";
Person.prototype.age = 29;
Person.prototype.job = "Software Engineer";
Person.prototype.sayName = function() {
  console.log(this.name);
};

let person1 = new Person();
person1.sayName(); // "Nicholas"

let person2 = new Person();
person2.sayName(); // "Nicholas"

console.log(person1.sayName == person2.sayName); // true
```

Here, the properties and the `sayName()` method are added directly to the `prototype` property of `Person`, leaving the constructor empty. However, it's still possible to call the constructor to create a new object and have the properties and methods present. Unlike the constructor pattern, the properties and methods are all shared among instances, so `person1` and `person2` are both accessing the same set of properties and the same `sayName()` function. To understand how this works, you must understand the nature of prototypes in ECMAScript.

How Prototypes Work

Whenever a function is created, its `prototype` property is also created according to a specific set of rules. By default, all prototypes automatically get a property called `constructor` that points back to the function on which it is a property. In the previous example, for instance, `Person.prototype.constructor` points to `Person`. Then, depending on the constructor, other properties and methods may be added to the prototype.

When defining a custom constructor, the prototype gets the `constructor` property only by default; all other methods are inherited from `Object`. Each time the constructor is called to create a new instance, that instance has an internal pointer to the constructor's prototype. In ECMA-262, this is called `[[Prototype]]`. There is no standard way to access `[[Prototype]]` from script, but Firefox, Safari, and Chrome all support a property on every object called `__proto__`; in other implementations, this property is completely hidden from script. The important thing to understand is that a direct link exists between the instance and the constructor's prototype but not between the instance and the constructor.

This relationship can be difficult to visualize, so refer to the following snippet as a sort of lookup table for overall prototype behavior:

```

/**
 * Constructor function can exist as function expression
 * or function declaration, so both of these are suitable:
 *   function Person {}
 *   let Person = function() {}
 */
function Person() {}

/**
 * Upon declaration, the constructor function already
 * has a prototype object associated with it:
 */
console.log(typeof Person.prototype);
console.log(Person.prototype);
// {
//   constructor: f Person(),
//   __proto__: Object
// }

/**
 * As mentioned previously, the constructor function has
 * a 'prototype' reference to the prototype object, and
 * the prototype object has a 'constructor' reference to
 * the constructor function. These references are cyclical:
 */
console.log(Person.prototype.constructor === Person); // true

/**
 * Any normal prototype chain will terminate at the Object prototype.
 * The prototype of the Object prototype is null.
 */
console.log(Person.prototype.__proto__ === Object.prototype); // true
console.log(Person.prototype.__proto__.constructor === Object); // true
console.log(Person.prototype.__proto__.__proto__ === null); // true

console.log(Person.prototype.__proto__);
// {
//   constructor: f Object(),
//   toString: ...
//   hasOwnProperty: ...
//   isPrototypeOf: ...
//   ...
// }

let person1 = new Person(),
    person2 = new Person();

/**
 * The constructor, the prototype object, and an instance
 * are three completely distinct objects:
 */

```



```

console.log(person1 !== Person);           // true
console.log(person1 !== Person.prototype); // true
console.log(Person.prototype !== person);  // true

/**
 * An instance is linked to the prototype through __proto__, which
 * is the literal manifestation of the [[Prototype]] hidden property.
 *
 * A constructor is linked to the prototype through the constructor property.
 *
 * An instance has no direct link to the constructor, only through the prototype.
 */
console.log(person1.__proto__ === Person.prototype); // true
console.log(person1.__proto__.constructor === Person); // true

/**
 * Two instances created from the same constructor function will share
 * a prototype object:
 */
console.log(person1.__proto__ === person2.__proto__); // true

/**
 * instanceof will check the instance's prototype chain against the
 * prototype property of a constructor function:
 */
console.log(person1 instanceof Person);           // true
console.log(person1 instanceof Object);           // true
console.log(Person.prototype instanceof Object); // true

```

Consider the original example using the `Person` constructor and `Person.prototype`. The relationship between the objects in the example is shown in Figure 8-1.

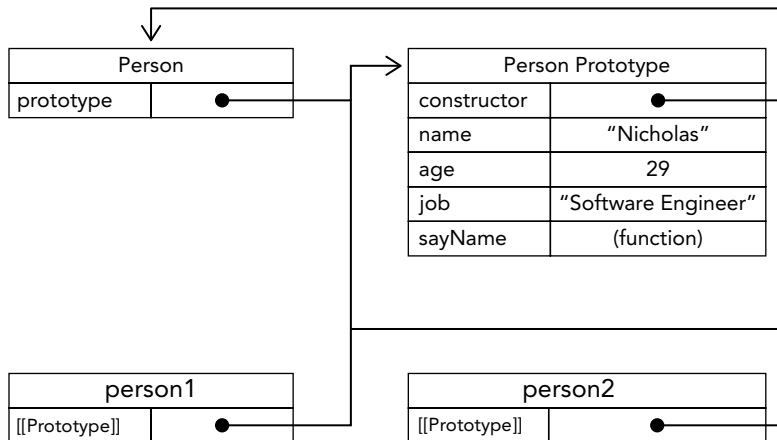

FIGURE 8-1:

Figure 8-1 shows the relationship between the `Person` constructor, the `Person`'s prototype, and the two instances of `Person` that exist. Note that `Person.prototype` points to the prototype object but `Person.prototype.constructor` points back to `Person`. The prototype contains the constructor

property and the other properties that were added. Each instance of `Person`, `person1`, and `person2` has internal properties that point back to `Person.prototype` only; each has no direct relationship with the constructor. Also note that even though neither of these instances have properties or methods, `person1.sayName()` works. This is due to the lookup procedure for object properties.

Even though `[[Prototype]]` is not accessible in all implementations, the `isPrototypeOf()` method can be used to determine if this relationship exists between objects. Essentially, `isPrototypeOf()` returns `true` if `[[Prototype]]` points to the prototype on which the method is being called, as shown here:

```
console.log(Person.prototype.isPrototypeOf(person1)); // true
console.log(Person.prototype.isPrototypeOf(person2)); // true
```

In this code, the prototype's `isPrototypeOf()` method is called on both `person1` and `person2`. Because both instances have a link to `Person.prototype`, it returns `true`.

The ECMAScript Object type has a method called `Object.getPrototypeOf()`, which returns the value of `[[Prototype]]`. For example:

```
console.log(Object.getPrototypeOf(person1) == Person.prototype); // true
console.log(Object.getPrototypeOf(person1).name); // "Nicholas"
```

The first line of this code simply confirms that the object returned from `Object.getPrototypeOf()` is actually the prototype of the object. The second line retrieves the value of the `name` property on the prototype, which is `"Nicholas"`. Using `Object.getPrototypeOf()`, you are able to retrieve an object's prototype easily, which becomes important once you want to implement inheritance using the prototype (discussed later in this chapter).

The Object type also features a `setPrototypeOf()` method, which writes a new value into the `[[Prototype]]` of the instance. This allows you to overwrite the prototype hierarchy of an already-instantiated object:

```
let biped = {
  numLegs: 2
};
let person = {
  name: 'Matt'
};

Object.setPrototypeOf(person, biped);

console.log(person.name); // Matt
console.log(person.numLegs); // 2
console.log(Object.getPrototypeOf(person) === biped); // true
```

WARNING: *The `Object.setPrototypeOf()` operation will likely cause severe performance slowdowns when used. The Mozilla documentation puts it best: "In every browser and JavaScript engine, the effects on performance of altering inheritance are subtle and far-flung, and are not limited to simply the time spent in `Object.setPrototypeOf()` statement, but may extend to any code that has access to any object whose `[[Prototype]]` has been altered."*

To avoid these slowdowns, prefer to just create a new object and specify its prototype with

```
Object.create():

let biped = {
  numLegs: 2
};
let person = Object.create(biped);
person.name = 'Matt';

console.log(person.name); // Matt
console.log(person.numLegs); // 2
console.log(Object.getPrototypeOf(person) === biped); // true
```

Understanding the Prototype Hierarchy

Whenever a property is accessed for reading on an object, a search is started to find a property with that name. The search begins on the object instance itself. If a property with the given name is found on the instance, then that value is returned; if the property is not found, then the search continues up the pointer to the prototype, and the prototype is searched for a property with the same name. If the property is found on the prototype, then that value is returned. So, when `person1.sayName()` is called, a two-step process happens. First, the JavaScript engine asks, "Does the instance `person1` have a property called `sayName`?" The answer is no, so it continues the search and asks, "Does the `person1` prototype have a property called `sayName`?" The answer is yes, so the function stored on the prototype is accessed. When `person2.sayName()` is called, the same search executes, ending with the same result. This is how prototypes are used to share properties and methods among multiple object instances.

NOTE *The constructor property mentioned earlier exists only on the prototype and so is accessible from object instances.*

Although it's possible to read values on the prototype from object instances, it is not possible to overwrite them. If you add a property to an instance that has the same name as a property on the prototype, you create the property on the instance, which then masks the property on the prototype. Here's an example:

```
function Person() {}

Person.prototype.name = "Nicholas";
Person.prototype.age = 29;
Person.prototype.job = "Software Engineer";
Person.prototype.sayName = function() {
  console.log(this.name);
};

let person1 = new Person();
let person2 = new Person();

person1.name = "Greg";
console.log(person1.name); // "Greg" - from instance
console.log(person2.name); // "Nicholas" - from prototype
```

In this example, the `name` property of `person1` is shadowed by a new value. Both `person1.name` and `person2.name` still function appropriately, returning "Greg" (from the object instance) and "Nicholas" (from the prototype), respectively. When `person1.name` was accessed in the `console.log()`, its value was read, so the search began for a property called `name` on the instance. Because the property exists, it is used without searching the prototype. When `person2.name` is accessed the same way, the search doesn't find the property on the instance, so it continues to search on the prototype where the `name` property is found.

Once a property is added to the object instance, it *shadows* any properties of the same name on the prototype, which means that it blocks access to the property on the prototype without altering it. Even setting the property to `null` only sets the property on the instance and doesn't restore the link to the prototype. The `delete` operator, however, completely removes the instance property and allows the prototype property to be accessed again as follows:

```
function Person() {}

Person.prototype.name = "Nicholas";
Person.prototype.age = 29;
Person.prototype.job = "Software Engineer";
Person.prototype.sayName = function() {
  console.log(this.name);
};

let person1 = new Person();
let person2 = new Person();

person1.name = "Greg";
console.log(person1.name); // "Greg" - from instance
console.log(person2.name); // "Nicholas" - from prototype

delete person1.name;
console.log(person1.name); // "Nicholas" - from the prototype
```

In this modified example, `delete` is called on `person1.name`, which previously had been shadowed with the value "Greg". This restores the link to the prototype's `name` property, so the next time `person1.name` is accessed, it's the prototype property's value that is returned.

The `hasOwnProperty()` method determines if a property exists on the instance or on the prototype. This method, which is inherited from `Object`, returns `true` only if a property of the given name exists on the object instance, as in this example:

```
function Person() {}

Person.prototype.name = "Nicholas";
Person.prototype.age = 29;
Person.prototype.job = "Software Engineer";
Person.prototype.sayName = function() {
  console.log(this.name);
};

let person1 = new Person();
let person2 = new Person();
```

```

console.log(person1.hasOwnProperty("name")); // false

person1.name = "Greg";
console.log(person1.name); // "Greg" - from instance
console.log(person1.hasOwnProperty("name")); // true

console.log(person2.name); // "Nicholas" - from prototype
console.log(person2.hasOwnProperty("name")); // false

delete person1.name;
console.log(person1.name); // "Nicholas" - from the prototype
console.log(person1.hasOwnProperty("name")); // false

```

By injecting calls to `hasOwnProperty()` in this example, it becomes clear when the instance's property is being accessed and when the prototype's property is being accessed. Calling `person1.hasOwnProperty("name")` returns `true` only after `name` has been overwritten on `person1`, indicating that it now has an instance property instead of a prototype property. Figure 8-2 illustrates the various steps being taken in this example. (For simplicity, the relationship to the `Person` constructor has been omitted.)

Initially

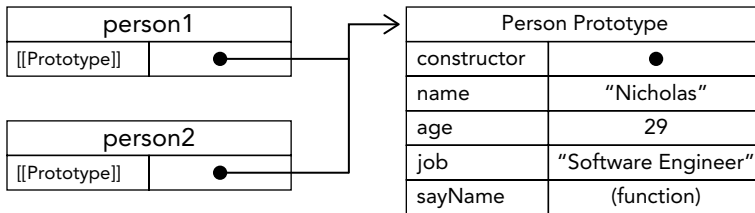

`person1.name = "Greg"`

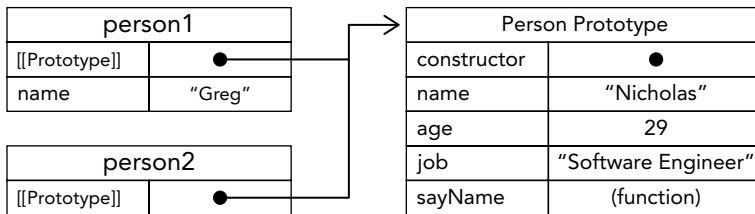

`delete person1.name`

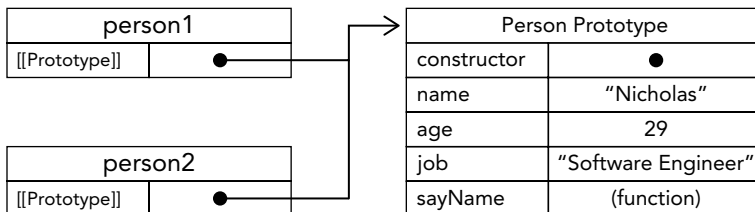

FIGURE 8-2:

NOTE *The ECMAScript `Object.getOwnPropertyDescriptor()` method works only on instance properties; to retrieve the descriptor of a prototype property, you must call `Object.getOwnPropertyDescriptor()` on the prototype object directly.*

Prototypes and the “in” Operator

There are two ways to use the `in` operator: on its own or as a `for-in` loop. When used on its own, the `in` operator returns `true` when a property of the given name is accessible by the object, which is to say that the property may exist on the instance or on the prototype. Consider the following example:

```
function Person() {}

Person.prototype.name = "Nicholas";
Person.prototype.age = 29;
Person.prototype.job = "Software Engineer";
Person.prototype.sayName = function() {
  console.log(this.name);
};

let person1 = new Person();
let person2 = new Person();

console.log(person1.hasOwnProperty("name")); // false
console.log("name" in person1); // true

person1.name = "Greg";
console.log(person1.name); // "Greg" - from instance
console.log(person1.hasOwnProperty("name")); // true
console.log("name" in person1); // true

console.log(person2.name); // "Nicholas" - from prototype
console.log(person2.hasOwnProperty("name")); // false
console.log("name" in person2); // true

delete person1.name;
console.log(person1.name); // "Nicholas" - from the prototype
console.log(person1.hasOwnProperty("name")); // false
console.log("name" in person1); // true
```

Throughout the execution of this code, the property name is available on each object either directly or from the prototype. Therefore, calling `"name" in person1` always returns `true`, regardless of whether the property exists on the instance. It's possible to determine if the property of an object exists on the prototype by combining a call to `hasOwnProperty()` with the `in` operator like this:

```
function hasPrototypeProperty(object, name){
  return !object.hasOwnProperty(name) && (name in object);
}
```

Because the `in` operator always returns `true` as long as the property is accessible by the object, and `hasOwnProperty()` returns `true` only if the property exists on the instance, a prototype property can be determined if the `in` operator returns `true` but `hasOwnProperty()` returns `false`. Consider the following example:

```
function Person() {}

Person.prototype.name = "Nicholas";
Person.prototype.age = 29;
Person.prototype.job = "Software Engineer";
Person.prototype.sayName = function() {
  console.log(this.name);
};

let person = new Person();
console.log(hasPrototypeProperty(person, "name")); // true

person.name = "Greg";
console.log(hasPrototypeProperty(person, "name")); // false
```

In this code, the `name` property first exists on the prototype, so `hasPrototypeProperty()` returns `true`. Once the `name` property is overwritten, it exists on the instance, so `hasPrototypeProperty()` returns `false`. Even though the `name` property still exists on the prototype, it is no longer used because the instance property now exists.

When using a `for-in` loop, all properties that are accessible by the object and can be enumerated will be returned, which includes properties both on the instance and on the prototype. Instance properties that shadow a non-enumerable prototype property (a property that has `[[Enumerable]]` set to `false`) will be returned in the `for-in` loop because all developer-defined properties are enumerable by default.

To retrieve a list of all enumerable instance properties on an object, you can use the `Object.keys()` method, which accepts an object as its argument and returns an array of strings containing the names of all enumerable properties. For example:

```
function Person() {}

Person.prototype.name = "Nicholas";
Person.prototype.age = 29;
Person.prototype.job = "Software Engineer";
Person.prototype.sayName = function() {
  console.log(this.name);
};

let keys = Object.keys(Person.prototype);
console.log(keys); // "name,age,job,sayName"
let p1 = new Person();
p1.name = "Rob";
p1.age = 31;
let p1keys = Object.keys(p1);
console.log(p1keys); // "name,age"
```

Here, the `keys` variable is filled with an array containing `"name"`, `"age"`, `"job"`, and `"sayName"`. This is the order in which they would normally appear using `for-in`. When called on an instance of `Person`, `Object.keys()` returns an array of `name` and `age`, the only two instance properties.

If you'd like a list of all instance properties, whether enumerable or not, you can use `Object.getOwnPropertyNames()` in the same way:

```
let keys = Object.getOwnPropertyNames(Person.prototype);
console.log(keys); // "constructor, name, age, job, sayName"
```

Note the inclusion of the non-enumerable `constructor` property in the list of results. Both `Object.keys()` and `Object.getOwnPropertyNames()` may be suitable replacements for using `for-in`.

With the introduction of symbols in ECMAScript 6, the need for a sibling method to `Object.getOwnPropertyNames()` became apparent because symbol-keyed properties do not have a concept of a name. Therefore, `Object.getOwnPropertySymbols()` was introduced, which offers the same behavior as `Object.getOwnPropertyNames()` but with respect to symbols:

```
let k1 = Symbol('k1'),
    k2 = Symbol('k2');

let o = {
  [k1]: 'k1',
  [k2]: 'k2'
};

console.log(Object.getOwnPropertySymbols(o));
// [Symbol(k1), Symbol(k2)]
```

Property Enumeration Order

`for-in` loops, `Object.keys()`, `Object.getOwnPropertyNames/Symbols()`, and `Object.assign()` have an important distinction when it comes to property enumeration order. `for-in` loops and `Object.keys()` do not have a deterministic order of enumeration—these are determined by the JavaScript engine and may vary by browser.

`Object.getOwnPropertyNames()`, `Object.getOwnPropertySymbols()`, and `Object.assign()`, however, *do* have a deterministic enumeration order. Number keys will first be enumerated in ascending order, then string and symbol keys enumerated in insertion order. Keys defined inline in an object literal will be inserted in their comma delimited order.

```
let k1 = Symbol('k1'),
    k2 = Symbol('k2');

let o = {
  1: 1,
  first: 'first',
  [k1]: 'sym2',
  second: 'second',
  0: 0
};

o[k2] = 'sym2';
o[3] = 3;
o.third = 'third';
o[2] = 2;

console.log(Object.getOwnPropertyNames(o));
```



```
// ["0", "1", "3", "first", "second", "third"]

console.log(Object.getOwnPropertySymbols(o));
// [Symbol(k1), Symbol(k2)]
```

Object Iteration

For most of JavaScript history, iterating the properties of an object was a messy affair. The ECMAScript 2017 introduced two static methods for converting an object's contents into a serialized—and more importantly, iterable—format. These static methods, `Object.values()` and `Object.entries()`, accept an object and return its contents in an array. `Object.values()` returns an array of the object's values, and `Object.entries()` returns an array of array pairs, each representing a `[key, value]` pair in the object.

These methods are demonstrated here:

```
const o = {
  foo: 'bar',
  baz: 1,
  qux: {}
};

console.log(Object.values(o));
// ["bar", 1, {}]

console.log(Object.entries(o));
// [["foo", "bar"], ["baz", 1], ["qux", {}]]
```

Note that non-string properties are converted to strings in the output array. Furthermore, the method performs a shallow copy of the object:

```
const o = {
  qux: {}
};

console.log(Object.values(o)[0] === o.qux);
// true

console.log(Object.entries(o)[0][1] === o.qux);
// true
```

Symbol-keyed properties are ignored:

```
const sym = Symbol();
const o = {
  [sym]: 'foo'
};

console.log(Object.values(o));
// []

console.log(Object.entries(o));
// []
```

Alternate Prototype Syntax

You may have noticed in the previous example that `Person.prototype` had to be typed out for each property and method. To limit this redundancy and to better visually encapsulate functionality on the prototype, it has become more common to simply overwrite the prototype with an object literal that contains all of the properties and methods, as in this example:

```
function Person() {}

Person.prototype = {
  name: "Nicholas",
  age: 29,
  job: "Software Engineer",
  sayName() {
    console.log(this.name);
  }
};
```

In this rewritten example, the `Person.prototype` property is set equal to a new object created with an object literal. The end result is the same, with one exception: the `constructor` property no longer points to `Person`. When a function is created, its `prototype` object is created and the `constructor` is automatically assigned. Essentially, this syntax overwrites the default `prototype` object completely, meaning that the `constructor` property is equal to that of a completely new object (the `Object` constructor) instead of the function itself. Although the `instanceof` operator still works reliably, you cannot rely on the `constructor` to indicate the type of object, as this example shows:

```
let friend = new Person();

console.log(friend instanceof Object); // true
console.log(friend instanceof Person); // true
console.log(friend.constructor == Person); // false
console.log(friend.constructor == Object); // true
```

Here, `instanceof` still returns `true` for both `Object` and `Person`, but the `constructor` property is now equal to `Object` instead of `Person`. If the `constructor`'s value is important, you can set it specifically back to the appropriate value, as shown here:

```
function Person() {
}

Person.prototype = {
  constructor: Person,
  name: "Nicholas",
  age: 29,
  job: "Software Engineer",
  sayName() {
    console.log(this.name);
  }
};
```

This code specifically includes a `constructor` property and sets it equal to `Person`, ensuring that the property contains the appropriate value.

Keep in mind that restoring the constructor in this manner creates a property with `[[Enumerable]]` set to `true`. Native constructor properties are not enumerable by default, so if you're using an ECMAScript-compliant JavaScript engine, you may wish to use `Object.defineProperty()` instead:

```
function Person() {}

Person.prototype = {
  name: "Nicholas",
  age: 29,
  job: "Software Engineer",
  sayName() {
    console.log(this.name);
  }
};

// restore the constructor
Object.defineProperty(Person.prototype, "constructor", {
  enumerable: false,
  value: Person
});
```

Dynamic Nature of Prototypes

Because the process of looking up values on a prototype is a search, changes made to the prototype at any point are immediately reflected on instances, even the instances that existed before the change was made. Here's an example:

```
let friend = new Person();

Person.prototype.sayHi = function() {
  console.log("hi");
};

friend.sayHi(); // "hi" - works!
```

In this code, an instance of `Person` is created and stored in `friend`. The next statement adds a method called `sayHi()` to `Person.prototype`. Even though the `friend` instance was created prior to this change, it still has access to the new method. This happens because of the loose link between the instance and the prototype. When `friend.sayHi()` is called, the instance is first searched for a property named `sayHi`; when it's not found, the search continues to the prototype. Because the link between the instance and the prototype is simply a pointer, not a copy, the search finds the new `sayHi` property on the prototype and returns the function stored there.

Although properties and methods may be added to the prototype at any time, and they are reflected instantly by all object instances, you cannot overwrite the entire prototype and expect the same behavior. The `[[Prototype]]` pointer is assigned when the constructor is called, so changing the prototype to a different object severs the tie between the constructor and the original prototype. Remember that the instance has a pointer to only the prototype, not to the constructor. Consider the following:

```
function Person() {}

let friend = new Person();
```

```

Person.prototype = {
  constructor: Person,
  name: "Nicholas",
  age: 29,
  job: "Software Engineer",
  sayName() {
    console.log(this.name);
  }
};

friend.sayName(); // error

```

In this example, a new instance of `Person` is created before the prototype object is overwritten. When `friend.sayName()` is called, it causes an error, because the prototype that `friend` points to doesn't contain a property of that name. Figure 8-3 illustrates why this happens.

Overwriting the prototype on the constructor means that new instances will reference the new prototype while any previously existing object instances still reference the old prototype.

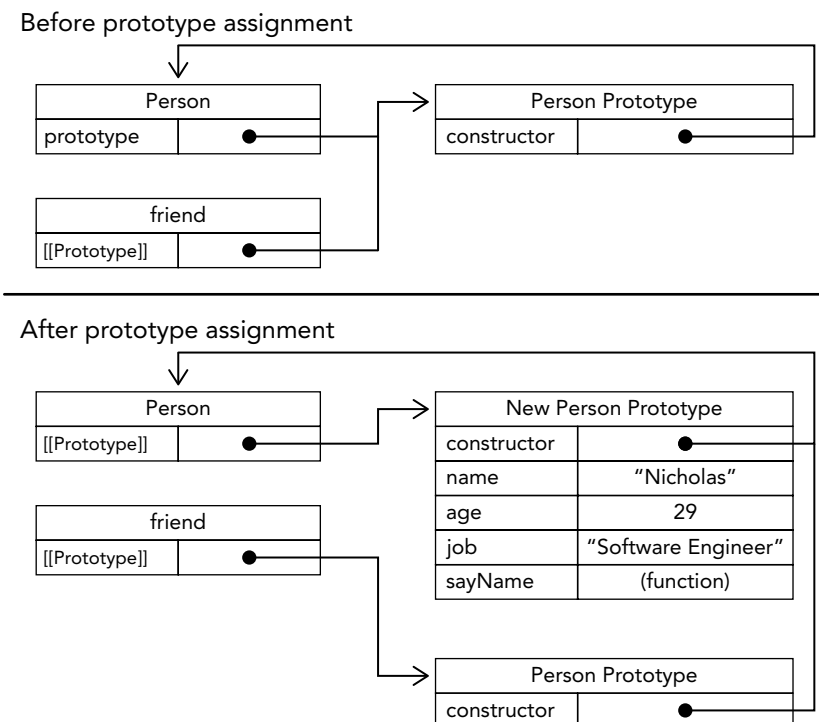

FIGURE 8-3:

Native Object Prototypes

The prototype pattern is important not just for defining custom types but also because it is the pattern used to implement all of the native reference types. Each of these (including `Object`, `Array`, `String`, and so on) has its methods defined on the constructor's prototype. For instance, the `sort()`

method can be found on `Array.prototype`, and `substring()` can be found on `String.prototype`, as shown here:

```
console.log(typeof Array.prototype.sort);    // "function"
console.log(typeof String.prototype.substring); // "function"
```

Through native object prototypes, it's possible to get references to all of the default methods and to define new methods. Native object prototypes can be modified just like custom object prototypes, so methods can be added at any time. For example, the following code adds a method called `startsWith()` to the `String` primitive wrapper:

```
String.prototype.startsWith = function (text) {
  return this.indexOf(text) === 0;
};

let msg = "Hello world!";
console.log(msg.startsWith("Hello")); // true
```

The `startsWith()` method in this example returns `true` if some given text occurs at the beginning of a string. The method is assigned to `String.prototype`, making it available to all strings in the environment. Since `msg` is a string, the `String` primitive wrapper is created behind the scenes, making `startsWith()` accessible.

NOTE *Although possible, it is not recommended to modify native object prototypes in a production environment. This can often cause confusion and create possible name collisions if a method that didn't exist natively in one browser is implemented natively in another. It's also possible to accidentally overwrite native methods. The preferred method is to create a custom class that inherits from the native type.*

Problems with Prototypes

The prototype pattern isn't without its faults. For one, it negates the ability to pass initialization arguments into the constructor, meaning that all instances get the same property values by default. Although this is an inconvenience, it isn't the biggest problem with prototypes. The main problem comes with their shared nature.

All properties on the prototype are shared among instances, which is ideal for functions. Properties that contain primitive values also tend to work well, as shown in the previous example, where it's possible to hide the `prototype` property by assigning a property of the same name to the instance. The real problem occurs when a property contains a reference value. Consider the following example:

```
function Person() {}

Person.prototype = {
  constructor: Person,
  name: "Nicholas",
```

```
    age: 29,  
    job: "Software Engineer",  
    friends: ["Shelby", "Court"],  
    sayName() {  
      console.log(this.name);  
    }  
  }  
};  
  
let person1 = new Person();  
let person2 = new Person();  
  
person1.friends.push("Van");  
  
console.log(person1.friends); // "Shelby,Court,Van"  
console.log(person2.friends); // "Shelby,Court,Van"  
console.log(person1.friends === person2.friends); // true
```

Here, the `Person.prototype` object has a property called `friends` that contains an array of strings. Two instances of `Person` are then created. The `person1.friends` array is altered by adding another string. Because the `friends` array exists on `Person.prototype`, not on `person1`, the changes made are also reflected on `person2.friends` (which points to the same array). If the intention is to have an array shared by all instances, then this outcome is okay. Typically, though, instances want to have their own copies of all properties. This is why the prototype pattern is rarely used on its own.

INHERITANCE

The concept most often discussed in relation to OO programming is inheritance. Many OO languages support two types of inheritance: interface inheritance, where only the method signatures are inherited, and implementation inheritance, where actual methods are inherited. Interface inheritance is not possible in ECMAScript because functions do not have signatures. Implementation inheritance is the only type of inheritance supported by ECMAScript, and this is done primarily through the use of prototype chaining.

Prototype Chaining

ECMA-262 describes *prototype chaining* as the primary method of inheritance in ECMAScript. The basic idea is to use the concept of prototypes to inherit properties and methods between two reference types. Recall the relationship between constructors, prototypes, and instances: each constructor has a prototype object that points back to the constructor, and instances have an internal pointer to the prototype. What if the prototype were actually an instance of another type? That would mean the prototype itself would have a pointer to a different prototype that, in turn, would have a pointer to another constructor. If that prototype were also an instance of another type, then the pattern would continue, forming a chain between instances and prototypes. This is the basic idea behind prototype chaining.

Implementing prototype chaining involves the following code pattern:

```
function SuperType() {
  this.property = true;
}

SuperType.prototype.getSuperValue = function() {
  return this.property;
};

function SubType() {
  this.subproperty = false;
}

// inherit from SuperType
SubType.prototype = new SuperType();

SubType.prototype.getSubValue = function () {
  return this.subproperty;
};

let instance = new SubType();
console.log(instance.getSuperValue()); // true
```

This code defines two types: `SuperType` and `SubType`. Each type has a single property and a single method. The main difference between the two is that `SubType` inherits from `SuperType` by creating a new instance of `SuperType` and assigning it to `SubType.prototype`. This overwrites the original prototype and replaces it with a new object, which means that all properties and methods that typically exist on an instance of `SuperType` now also exist on `SubType.prototype`. After the inheritance takes place, a method is assigned to `SubType.prototype`, adding a new method on top of what was inherited from `SuperType`. The relationship between the instance and both constructors and prototypes is displayed in Figure 8-4.

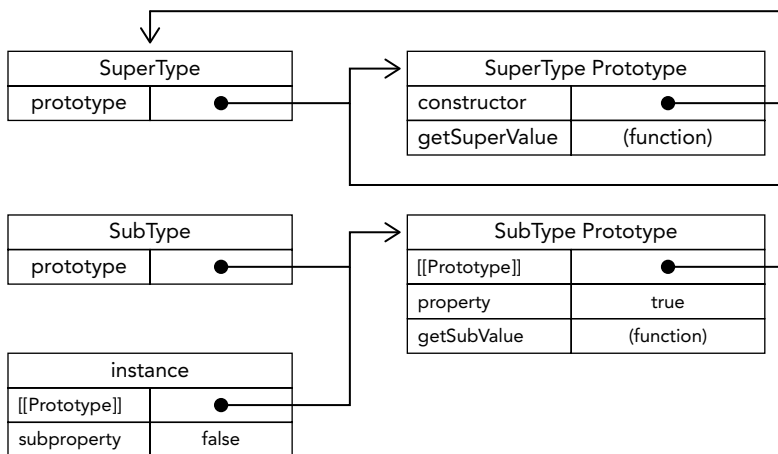

FIGURE 8-4:

Instead of using the default prototype of `SubType`, a new prototype is assigned. That new prototype happens to be an instance of `SuperType`, so it not only gets the properties and methods of a `SuperType` instance but also points back to the `SuperType`'s prototype. So `instance` points to `SubType.prototype` and `SubType.prototype` points to `SuperType.prototype`. Note that the `getSuperValue()` method remains on the `SuperType.prototype` object, but `property` ends up on `SubType.prototype`. That's because `getSuperValue()` is a prototype method, and `property` is an instance property. `SubType.prototype` is now an instance of `SuperType` so `property` is stored there. Also note that `instance.constructor` points to `SuperType` because the `constructor` property on the `SubType.prototype` was overwritten.

Prototype chaining extends to the prototype search mechanism described earlier. As you may recall, when a property is accessed in read mode on an instance, the property is first searched for on the instance. If the property is not found, then the search continues to the prototype. When inheritance has been implemented via prototype chaining, that search can continue up the prototype chain. In the previous example, for instance, a call to `instance.getSuperValue()` results in a three-step search: the instance, `SubType.prototype`, and `SuperType.prototype`, where the method is found. The search for properties and methods always continues until the end of the prototype chain is reached.

Default Prototypes

In reality, there is another step in the prototype chain. All reference types inherit from `Object` by default, which is accomplished through prototype chaining. The default prototype for any function is an instance of `Object`, meaning that its internal prototype pointer points to `Object.prototype`. This is how custom types inherit all of the default methods such as `toString()` and `valueOf()`. So the previous example has an extra layer of inheritance. Figure 8-5 shows the complete prototype chain.

`SubType` inherits from `SuperType`, and `SuperType` inherits from `Object`. When `instance.toString()` is called, the method being called actually exists on `Object.prototype`.

Prototype and Instance Relationships

The relationship between prototypes and instances is discernible in two ways. The first way is to use the `instanceof` operator, which returns `true` whenever an instance is used with a constructor that appears in its prototype chain, as in this example:

```
console.log(instance instanceof Object);    // true
console.log(instance instanceof SuperType); // true
console.log(instance instanceof SubType);   // true
```

Here, the `instance` object is technically an instance of `Object`, `SuperType`, and `SubType` because of the prototype chain relationship. The result is that `instanceof` returns `true` for all of these constructors.

The second way to determine this relationship is to use the `isPrototypeOf()` method. Each prototype in the chain has access to this method, which returns `true` for an instance in the chain, as in this example:

```
console.log(Object.prototype.isPrototypeOf(instance)); // true
console.log(SuperType.prototype.isPrototypeOf(instance)); // true
console.log(SubType.prototype.isPrototypeOf(instance)); // true
```

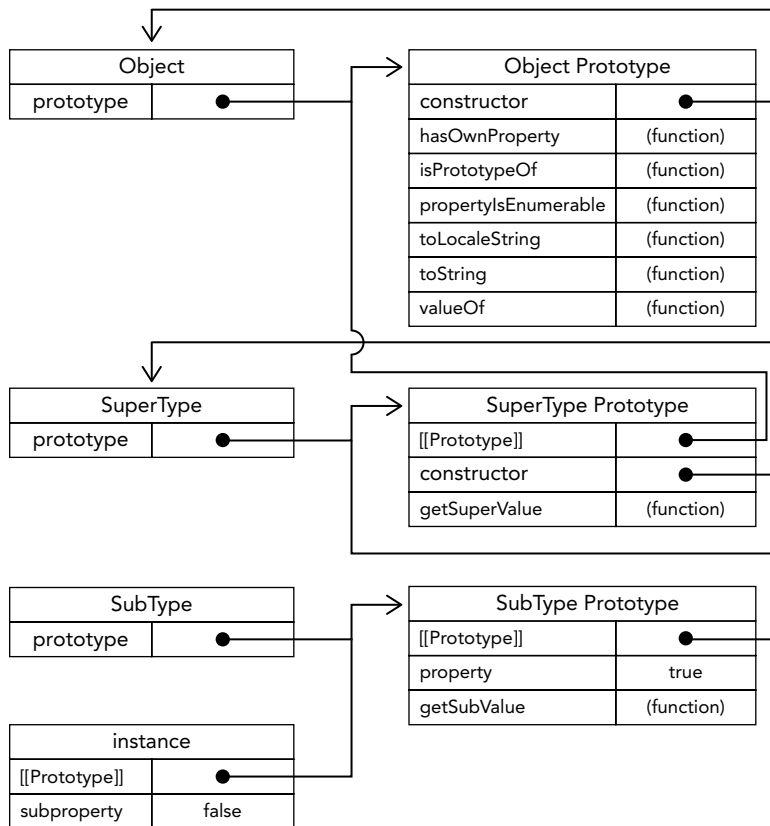



FIGURE 8-5:

Working with Methods

Often a subtype will need to either override a supertype method or introduce new methods that don't exist on the supertype. To accomplish this, the methods must be added to the prototype after the prototype has been assigned. Consider this example:

```
function SuperType() {
  this.property = true;
}

SuperType.prototype.getSuperValue = function() {
  return this.property;
};

function SubType() {
  this.subproperty = false;
}
```

```

// inherit from SuperType
SubType.prototype = new SuperType();

// new method
SubType.prototype.getSubValue = function () {
  return this.subproperty;
};

// override existing method
SubType.prototype.getSuperValue = function () {
  return false;
};

let instance = new SubType();
console.log(instance.getSuperValue()); // false

```

In this code, the highlighted area shows two methods. The first is `getSubValue()`, which is a new method on the `SubType`. The second is `getSuperValue()`, which already exists in the prototype chain but is being shadowed here. When `getSuperValue()` is called on an instance of `SubType`, it will call this one, but instances of `SuperType` will still call the original. The important thing to note is that both of the methods are defined after the prototype has been assigned as an instance of `SuperType`.

Another important thing to understand is that the object literal approach to creating prototype methods cannot be used with prototype chaining because you end up overwriting the chain. Here's an example:

```

function SuperType() {
  this.property = true;
}

SuperType.prototype.getSuperValue = function() {
  return this.property;
};

function SubType() {
  this.subproperty = false;
}

// inherit from SuperType
SubType.prototype = new SuperType();

// try to add new methods - this nullifies the previous line
SubType.prototype = {
  getSubValue() {
    return this.subproperty;
  },

  someOtherMethod() {
    return false;
  }
};

let instance = new SubType();
console.log(instance.getSuperValue()); // error!

```

In this code, the prototype is reassigned to be an object literal after it was already assigned to be an instance of `SuperType`. The prototype now contains a new instance of `Object` instead of an instance of `SuperType`, so the prototype chain has been broken. There is no relationship between `SubType` and `SuperType`.

Problems with Prototype Chaining

Even though prototype chaining is a powerful tool for inheritance, it is not without its issues. The major issue revolves around prototypes that contain reference values. Recall from earlier that prototype properties containing reference values are shared with all instances; this is why properties are typically defined within the constructor instead of on the prototype. When implementing inheritance using prototypes, the prototype actually becomes an instance of another type, meaning that what once were instance properties are now prototype properties. The issue is highlighted by the following example:

```
function SuperType() {
  this.colors = ["red", "blue", "green"];
}

function SubType() {}

// inherit from SuperType
SubType.prototype = new SuperType();

let instance1 = new SubType();
instance1.colors.push("black");
console.log(instance1.colors); // "red,blue,green,black"

let instance2 = new SubType();
console.log(instance2.colors); // "red,blue,green,black"
```

In this example, the `SuperType` constructor defines a property, `colors`, that contains an array (a reference value). Each instance of `SuperType` has its own `colors` property containing its own array. When `SubType` inherits from `SuperType` via prototype chaining, `SubType.prototype` becomes an instance of `SuperType` and so it gets its own `colors` property, which is akin to specifically creating `SubType.prototype.colors`. The end result: all instances of `SubType` share a `colors` property. This is indicated as the changes made to `instance1.colors` are reflected on `instance2.colors`.

A second issue with prototype chaining is that you cannot pass arguments into the supertype constructor when the subtype instance is being created. In fact, there is no way to pass arguments into the supertype constructor without affecting all of the object instances. Because of this and the aforementioned issue with reference values on the prototype, prototype chaining is rarely used alone.

Constructor Stealing

In an attempt to solve the inheritance problem with reference values on prototypes, developers began using a technique called *constructor stealing* (also sometimes called object masquerading or classical inheritance). The basic idea is quite simple: call the supertype constructor from within the subtype constructor. Keeping in mind that functions are simply objects that execute code in a particular

context, the `apply()` and `call()` methods can be used to execute a constructor on the newly created object, as in this example:

```
function SuperType() {
  this.colors = ["red", "blue", "green"];
}

function SubType() {
  // inherit from SuperType
  SuperType.call(this);
}

let instance1 = new SubType();
instance1.colors.push("black");
console.log(instance1.colors); // "red,blue,green,black"

let instance2 = new SubType();
console.log(instance2.colors); // "red,blue,green"
```

The highlighted lines in this example show the single call that is used in constructor stealing. By using the `call()` method (or alternately, `apply()`), the `SuperType` constructor is called in the context of the newly created instance of `SubType`. Doing this effectively runs all of the object-initialization code in the `SuperType()` function on the new `SubType` object. The result is that each instance has its own copy of the `colors` property.

Passing Arguments

One advantage that constructor stealing offers over prototype chaining is the ability to pass arguments into the supertype constructor from within the subtype constructor. Consider the following:

```
function SuperType(name) {
  this.name = name;
}

function SubType() {
  // inherit from SuperType passing in an argument
  SuperType.call(this, "Nicholas");

  // instance property
  this.age = 29;
}

let instance = new SubType();
console.log(instance.name); // "Nicholas";
console.log(instance.age); // 29
```

In this code, the `SuperType` constructor accepts a single argument, `name`, which is simply assigned to a property. A value can be passed into the `SuperType` constructor when called from within the `SubType` constructor, effectively setting the `name` property for the `SubType` instance. To ensure that the `SuperType` constructor doesn't overwrite those properties, you can define additional properties on the subtype after the call to the supertype constructor.

Problems with Constructor Stealing

The downside to using constructor stealing exclusively is that it introduces the same problems as the constructor pattern for custom types: Methods must be defined inside the constructor, so there's no function reuse. Furthermore, methods defined on the supertype's prototype are not accessible on the subtype, so all types can use only the constructor pattern. Because of these issues, constructor stealing is rarely used on its own.

Combination Inheritance

Combination inheritance (sometimes also called pseudoclassical inheritance) combines prototype chaining and constructor stealing to get the best of each approach. The basic idea is to use prototype chaining to inherit properties and methods on the prototype and to use constructor stealing to inherit instance properties. This allows function reuse by defining methods on the prototype and allows each instance to have its own properties. Consider the following:

```
function SuperType(name){
  this.name = name;
  this.colors = ["red", "blue", "green"];
}

SuperType.prototype.sayName = function() {
  console.log(this.name);
};

function SubType(name, age){
  // inherit properties
  SuperType.call(this, name);

  this.age = age;
}

// inherit methods
SubType.prototype = new SuperType();

SubType.prototype.sayAge = function() {
  console.log(this.age);
};

let instance1 = new SubType("Nicholas", 29);
instance1.colors.push("black");
console.log(instance1.colors); // "red,blue,green,black"
instance1.sayName();         // "Nicholas";
instance1.sayAge();          // 29

let instance2 = new SubType("Greg", 27);
console.log(instance2.colors); // "red,blue,green"
instance2.sayName();          // "Greg";
instance2.sayAge();           // 27
```

In this example, the `SuperType` constructor defines two properties, `name` and `colors`, and the `SuperType` prototype has a single method called `sayName()`. The `SubType` constructor calls the `SuperType` constructor, passing in the `name` argument, and defines its own property, called `age`. Additionally, the

SubType prototype is assigned to be an instance of SuperType, and then a new method, called sayAge(), is defined. With this code, it's then possible to create two separate instances of SubType that have their own properties, including the colors property, but all use the same methods.

Addressing the downsides of both prototype chaining and constructor stealing, combination inheritance is the most frequently used inheritance pattern in JavaScript. It also preserves the behavior of instanceof and isPrototypeOf() for identifying the composition of objects.

Prototypal Inheritance

In 2006, Douglas Crockford wrote an article, “Prototypal Inheritance in JavaScript,” in which he introduced a method of inheritance that didn't involve the use of strictly defined constructors. His premise was that prototypes allow you to create new objects based on existing objects without the need for defining custom types. The function he introduced to this end is as follows:

```
function object(o) {
  function F() {}
  F.prototype = o;
  return new F();
}
```

The object() function creates a temporary constructor, assigns a given object as the constructor's prototype, and returns a new instance of the temporary type. Essentially, object() performs a shadow copy of any object that is passed into it. Consider the following:

```
let person = {
  name: "Nicholas",
  friends: ["Shelby", "Court", "Van"]
};

let anotherPerson = object(person);
anotherPerson.name = "Greg";
anotherPerson.friends.push("Rob");

let yetAnotherPerson = object(person);
yetAnotherPerson.name = "Linda";
yetAnotherPerson.friends.push("Barbie");

console.log(person.friends); // "Shelby, Court, Van, Rob, Barbie"
```

This is the way Crockford advocates using prototypal inheritance: you have an object that you want to use as the base of another object. That object should be passed into object(), and the resulting object should be modified accordingly. In this example, the person object contains information that should be available on another object, so it is passed into the object() function, which returns a new object. The new object has person as its prototype, meaning that it has both a primitive value property and a reference value property on its prototype. This also means that person.friends is shared not only by person but also with anotherPerson and yetAnotherPerson. Effectively, this code has created two clones of person.

ECMAScript 5 formalized the concept of prototypal inheritance by adding the Object.create() method. This method accepts two arguments, an object to use as the prototype for a new object and an optional object defining additional properties to apply to the new object. When used with one argument, Object.create() behaves the same as the object() method:

```
let person = {
  name: "Nicholas",
  friends: ["Shelby", "Court", "Van"]
};

let anotherPerson = Object.create(person);
anotherPerson.name = "Greg";
anotherPerson.friends.push("Rob");

let yetAnotherPerson = Object.create(person);
yetAnotherPerson.name = "Linda";
yetAnotherPerson.friends.push("Barbie");

console.log(person.friends); // "Shelby,Court,Van,Rob,Barbie"
```

The second argument for `Object.create()` is in the same format as the second argument for `Object.defineProperties()`: each additional property to define is specified along with its descriptor. Any properties specified in this manner will shadow properties of the same name on the prototype object. For example:

```
let person = {
  name: "Nicholas",
  friends: ["Shelby", "Court", "Van"]
};

let anotherPerson = Object.create(person, {
  name: {
    value: "Greg"
  }
});
console.log(anotherPerson.name); // "Greg"
```

Prototypal inheritance is useful when there is no need for the overhead of creating separate constructors, but you still need an object to behave similarly to another. Keep in mind that properties containing reference values will always share those values, similar to using the prototype pattern.

Parasitic Inheritance

Closely related to prototypal inheritance is the concept of *parasitic inheritance*, another pattern popularized by Crockford. The idea behind parasitic inheritance is similar to that of the parasitic constructor and factory patterns: create a function that does the inheritance, augments the object in some way, and then returns the object as if it did all the work. The basic parasitic inheritance pattern looks like this:

```
function createAnother(original){
  let clone = Object.create(original); // create a new object by calling a function
  clone.sayHi = function() { // augment the object in some way
    console.log("hi");
  };
  return clone; // return the object
}
```

In this code, the `createAnother()` function accepts a single argument, which is the object to base a new object on. This object, `original`, is passed into the `object()` function, and the result is assigned to `clone`. Next, the `clone` object is changed to have a new method called `sayHi()`. The last step is to return the object. The `createAnother()` function can be used in the following way:

```
let person = {
  name: "Nicholas",
  friends: ["Shelby", "Court", "Van"]
};

let anotherPerson = createAnother(person);
anotherPerson.sayHi(); // "hi"
```

The code in this example returns a new object based on `person`. The `anotherPerson` object has all of the properties and methods of `person` but adds a new method called `sayHi()`.

Parasitic inheritance is another pattern to use when you are concerned primarily with objects and not with custom types and constructors. The `object()` method is not required for parasitic inheritance; any function that returns a new object fits the pattern.

NOTE *Keep in mind that adding functions to objects using parasitic inheritance leads to inefficiencies related to function reuse, similar to the constructor pattern.*

Parasitic Combination Inheritance

Combination inheritance is not without its inefficiencies. The most inefficient part of the pattern is that the supertype constructor is always called twice: once to create the subtype's prototype, and once inside the subtype constructor. Essentially, the subtype prototype ends up with all of the instance properties of a supertype object, only to have it overwritten when the subtype constructor executes. Consider the combination inheritance example again:

```
function SuperType(name) {
  this.name = name;
  this.colors = ["red", "blue", "green"];
}

SuperType.prototype.sayName = function() {
  console.log(this.name);
};

function SubType(name, age) {
  SuperType.call(this, name); // second call to SuperType()

  this.age = age;
}

SubType.prototype = new SuperType(); // first call to SuperType()
SubType.prototype.constructor = SubType;
```



```

SubType.prototype.sayAge = function() {
  console.log(this.age);
};

```

The highlighted lines of code indicate when the `SuperType` constructor is executed. When this code is executed, `SubType.prototype` ends up with two properties: `name` and `colors`. These are instance properties for `SuperType`, but they are now on the `SubType`'s prototype. When the `SubType` constructor is called, the `SuperType` constructor is also called, which creates instance properties `name` and `colors` on the new object that mask the properties on the prototype. Figure 8-6 illustrates this process.

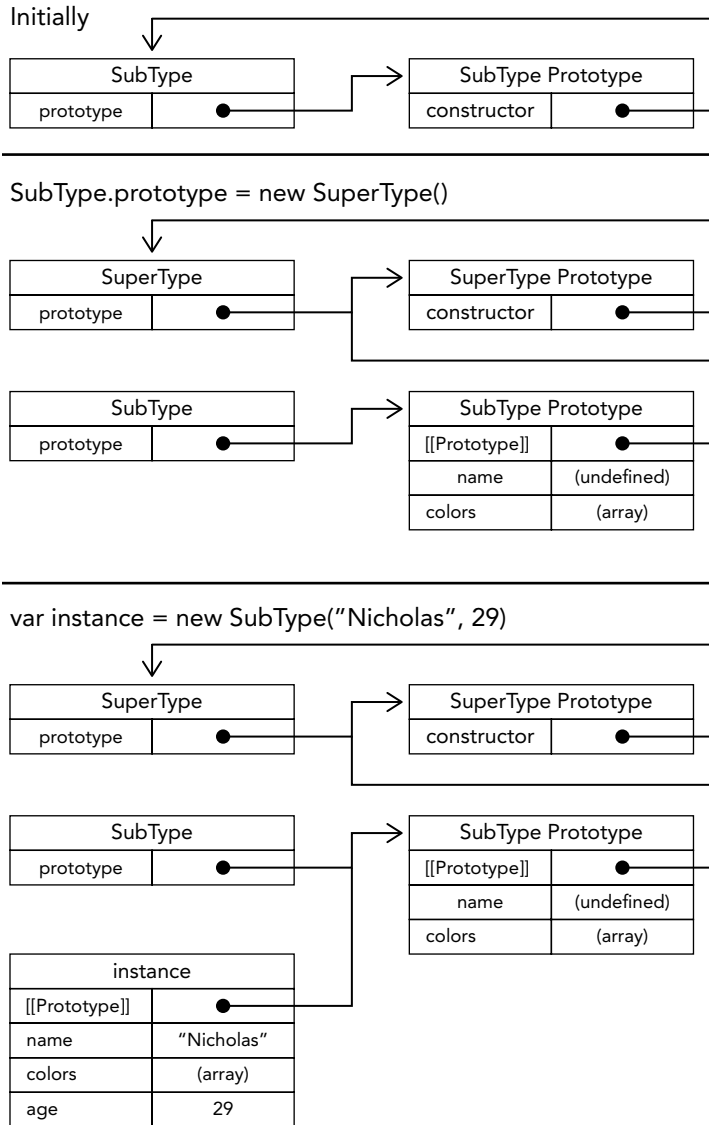

FIGURE 8-6:

As you can see, there are two sets of `name` and `colors` properties: one on the instance and one on the `SubType` prototype. This is the result of calling the `SuperType` constructor twice. Fortunately, there is a way around this.

Parasitic combination inheritance uses constructor stealing to inherit properties but uses a hybrid form of prototype chaining to inherit methods. The basic idea is this: Instead of calling the supertype constructor to assign the subtype's prototype, all you need is a copy of the supertype's prototype. Essentially, use parasitic inheritance to inherit from the supertype's prototype and then assign the result to the subtype's prototype. The basic pattern for parasitic combination inheritance is as follows:

```
function inheritPrototype(subType, superType) {
  let prototype = Object(superType.prototype); // create object
  prototype.constructor = subType;           // augment object
  subType.prototype = prototype;             // assign object
}
```

The `inheritPrototype()` function implements very basic parasitic combination inheritance. This function accepts two arguments: the subtype constructor and the supertype constructor. Inside the function, the first step is to create a clone of the supertype's prototype. Next, the `constructor` property is assigned onto `prototype` to account for losing the default `constructor` property when the prototype is overwritten. Finally, the subtype's prototype is assigned to the newly created object. A call to `inheritPrototype()` can replace the subtype prototype assignment in the previous example, as shown here:

```
function SuperType(name) {
  this.name = name;
  this.colors = ["red", "blue", "green"];
}

SuperType.prototype.sayName = function() {
  console.log(this.name);
};

function SubType(name, age) {
  SuperType.call(this, name);

  this.age = age;
}

inheritPrototype(SubType, SuperType);

SubType.prototype.sayAge = function() {
  console.log(this.age);
};
```

This example is more efficient in that the `SuperType` constructor is being called only one time, avoiding having unnecessary and unused properties on `SubType.prototype`. Furthermore, the prototype chain is kept intact, so both `instanceof` and `isPrototypeOf()` behave as they would normally. Parasitic combination inheritance is considered the most optimal inheritance paradigm for reference types.

CLASSES

The previous sections are an in-depth overview of how it was possible to emulate class-like behavior using only features available in ECMAScript 5. It is not difficult to conclude that the strategies shown presented various problems and tradeoffs. On top of this, the syntax was inarguably excessively verbose and messy.

To address these problems, newly introduced in ECMAScript 6 is the ability to formally define classes using the `class` keyword. Classes are a fundamentally new syntactical construct in ECMAScript, and therefore they may feel unfamiliar at first. Although ECMAScript 6 classes appear to feature canonical object-oriented programming, they still uses prototype and constructor concepts under the hood.

Class Definition Basics

Similar to the function type, there are two primary ways of defining a class: class declarations and class expressions. Both use the `class` keyword and curly braces:

```
// class declaration
class Person {}

// class expression
const Animal = class {};
```

Like function expressions, class expressions cannot be referenced until they are evaluated in execution. However, an important departure from the parallel behavior of function definition is that, while function declarations are hoisted, class declarations are not:

```
console.log(FunctionExpression); // undefined
var FunctionExpression = function() {};
console.log(FunctionExpression); // function() {}

console.log(FunctionDeclaration); // FunctionDeclaration() {}
function FunctionDeclaration() {}
console.log(FunctionDeclaration); // FunctionDeclaration() {}

console.log(ClassExpression); // undefined
var ClassExpression = class {};
console.log(ClassExpression); // class {}

console.log(ClassDeclaration); // ReferenceError: ClassDeclaration is not defined
class ClassDeclaration {}
console.log(ClassDeclaration); // class ClassDeclaration {}
```

Also a departure from function declarations, which are function scoped, class declarations are block scoped:

```
{
  function FunctionDeclaration() {}
  class ClassDeclaration {}
}
```

```

console.log(FunctionDeclaration); // FunctionDeclaration() {}
console.log(ClassDeclaration);    // ReferenceError: ClassDeclaration is not defined

```

Class Composition

A class can be composed of the class's constructor method, instance methods, getters, setters, and static class methods. None of these are explicitly required; an empty class definition is valid syntax. By default, everything inside a class definition executes in strict mode.

As with function constructors, most style guides will direct you to capitalize the class name to distinguish it from instances that are created from it (for example, `class Foo {}` might create an instance `foo`):

```

// Valid empty class definition
class Foo {}

// Valid class definition with constructor
class Bar {
  constructor() {}
}

// Valid class definition with getter
class Baz {
  get myBaz() {}
}

// Valid class definition with static method
class Qux {
  static myQux() {}
}

```

Class expressions may be optionally named. When the expression is assigned to a variable, the name property may be used to retrieve the class expression name string, but the identifier itself is not accessible outside the class expression scope.

```

let Person = class PersonName {
  identify() {
    console.log(Person.name, PersonName.name);
  }
}

let p = new Person();

p.identify(); // PersonName, PersonName

console.log(Person.name); // PersonName
console.log(PersonName); // ReferenceError: PersonName is not defined

```

The Class Constructor

The `constructor` keyword is used inside the class definition block to signal the definition of the class's constructor function. Using the method name `constructor` will signal to the interpreter that this particular function should be invoked to create a fresh instance using the `new` operator. Definition

of the constructor is optional; electing not to define the class constructor is the same as defining the constructor as an empty function.

Instantiation

Instantiating a `Person` using the `new` operator operates identically to using `new` with a function constructor. The only perceptible difference is that the JavaScript interpreter understands that using `new` with a class means the `constructor` function should be used for instantiation.

Calling a class constructor using `new` will do the following:

1. A new object is created in memory.
2. The new object's internal `[[Prototype]]` pointer is assigned to be the constructor's `prototype` property.
3. The `this` value of the constructor is assigned to the new object (so `this` points to the new object when referenced inside the constructor).
4. The code inside the constructor is executed (adds properties to the new object).
5. If the constructor function returns an object, that object is returned. Otherwise, the new object that was just created is returned.

```
class Animal {}

class Person {
  constructor() {
    console.log('person ctor');
  }
}

class Vegetable {
  constructor() {
    this.color = 'orange';
  }
}

let a = new Animal();

let p = new Person(); // person ctor

let v = new Vegetable();
console.log(v.color); // orange
```

Parameters provided when instantiating the class are used as parameters to the constructor function. If you do not require the use of parameters, empty parentheses following the class name are optional:

```
class Person {
  constructor(name) {
    console.log(arguments.length);
    this.name = name || null;
  }
}

let p1 = new Person; // 0
console.log(p1.name); // null
```

```

let p2 = new Person();           // 0
console.log(p2.name);           // null

let p3 = new Person('Jake');    // 1
console.log(p3.name);           // Jake

```

By default, the constructor will return the `this` object after execution. If an object is returned from the constructor function, that value will be used as the instantiated object and the newly created `this` object will be discarded if a reference to it is not preserved. However, if a different object is returned, the returned object will not be associated with the class via `instanceof` because its prototype pointer was never modified.

```

class Person {
  constructor(override) {
    this.foo = 'foo';
    if (override) {
      return {
        bar: 'bar'
      };
    }
  }
}

let p1 = new Person(),
    p2 = new Person(true);

console.log(p1);                // Person{ foo: 'foo' }
console.log(p1 instanceof Person); // true

console.log(p2);                // { bar: 'bar' }
console.log(p2 instanceof Person); // false

```

One major departure from function constructors is that the use of the `new` operator with class constructors is mandatory. With function constructors, when electing not to use the `new` operator, the constructor would use the global `this` value—typically the window object—inside the constructor. With class constructors, neglecting to use the `new` operator will throw an error:

```

function Person() {}

class Animal {}

// Constructs instance using window as 'this'
let p = Person();

let a = Animal();
// TypeError: class constructor Animal cannot be invoked without 'new'

```

The class constructor method is not special and, after instantiation, behaves as a regular instance method (with the same constructor restrictions). Because of this, you are able to reference and use it post-instantiation:

```

class Person {}

// Create a new instance using the class
let p1 = new Person();

```

```
p1.constructor();  
// TypeError: Class constructor Person cannot be invoked without 'new'  
  
// Create a new instance using the reference to the class constructor  
let p2 = new p1.constructor();
```

Understanding Classes as Special Functions

There is no formal class type in the ECMAScript specification, and in many ways ECMAScript classes behave like special functions. Once declared, the class identifier identifies as a function when checked with the `typeof` operator:

```
class Person {}  
  
console.log(Person);           // class Person {}  
console.log(typeof Person);   // function
```

The class identifier has a `prototype` property, and the prototype has a `constructor` property that refers back to the class itself:

```
class Person{}  
  
console.log(Person.prototype);           // { constructor: f() }  
console.log(Person === Person.prototype.constructor); // true
```

As with function constructors, you can use the `instanceof` operator to test if the constructor prototype appears in the prototype chain of an instance:

```
class Person {}  
  
let p = new Person();  
  
console.log(p instanceof Person); // true
```

You have likely come to understand that the `instanceof` operator checks an instance's prototype chain against a constructor function, which in this example would be checking the instance `p` against the constructor function `Person`, which appears to be a class.

As shown earlier, the class behaves in the same way as a constructor function, and in the context of classes, the class itself is considered the constructor when `new` is applied to it. Importantly, the constructor method inside the class definition is *not* considered to be the constructor, and will return `false` when used with `instanceof`. If the constructor method is invoked directly, this is the same as using a non-class function constructor, and the `instanceof` convention will reverse:

```
class Person {}  
  
let p1 = new Person();  
  
console.log(p1.constructor === Person);           // true  
console.log(p1 instanceof Person);               // true  
console.log(p1 instanceof Person.constructor);   // false  
  
let p2 = new Person.constructor();  
  
console.log(p2.constructor === Person);           // false
```

```

console.log(p2 instanceof Person);           // false
console.log(p2 instanceof Person.constructor); // true

```

Classes are first-class citizens in JavaScript, meaning they can be passed around as you would any other object or function reference:

```

// Classes may be defined anywhere a function would, such as inside an array:
let classList = [
  class {
    constructor(id) {
      this.id_ = id;
      console.log('instance ${this.id_}');
    }
  }
];

function createInstance(classDefinition, id) {
  return new classDefinition(id);
}

let foo = createInstance(classList[0], 3141); // instance 3141

```

Similar to an immediately invoked function expression, a class can also be immediately instantiated:

```

// Because it is a class expression, the class name is optional
let p = new class Foo {
  constructor(x) {
    console.log(x);
  }
}('bar'); // bar

console.log(p); // Foo {}

```

Instance, Prototype, and Class Members

The class definition syntax allows you to neatly define members that should exist on an object instance, members that should exist on the object prototype, and members that should exist on the class itself.

Instance Members

Each time `new <classname>` is invoked, the constructor function will execute. Inside this function, you are able to populate the freshly created instance (the `this` object) with “own” properties. There are no restrictions to what may be added to the new instance and no restrictions on members added after the constructor exits.

Each instance is assigned unique member objects, meaning nothing is shared on the prototype:

```

class Person {
  constructor() {
    // For this example, define a string with object wrapper
    // as to check object equality between instances below
    this.name = new String('Jack');
  }
}

```



```

    this.sayName = () => console.log(this.name);

    this.nicknames = ['Jake', 'J-Dog']
  }
}

let p1 = new Person(),
    p2 = new Person();

p1.sayName(); // Jack
p2.sayName(); // Jack

console.log(p1.name === p2.name);           // false
console.log(p1.sayName === p2.sayName);    // false
console.log(p1.nicknames === p2.nicknames); // false

p1.name = p1.nicknames[0];
p2.name = p2.nicknames[1];

p1.sayName(); // Jake
p2.sayName(); // J-Dog

```

Prototype Methods and Accessors

To allow for sharing of methods between instances, the class definition syntax allows for definition of methods on the prototype object inside the class body.

```

class Person {
  constructor() {
    // Everything added to 'this' will exist on each individual instance
    this.locate = () => console.log('instance');
  }

  // Everything defined in the class body is defined on the class prototype object
  locate() {
    console.log('prototype');
  }
}

let p = new Person();

p.locate();           // instance
Person.prototype.locate(); // prototype

```

Methods can be defined in either location, but member data such as primitives and objects cannot be added to the prototype inside the class body:

```

class Person {
  name: 'Jake'
}
// Uncaught SyntaxError: Unexpected token :

```

Class methods behave identically to object properties, meaning they can be keyed with strings, symbols, or computed values:

```

const symbolKey = Symbol('symbolKey');

class Person {

```

```

    stringKey() {
      console.log('invoked stringKey');
    }
    [symbolKey]() {
      console.log('invoked symbolKey');
    }
    ['computed' + 'Key']() {
      console.log('invoked computedKey');
    }
  }

let p = new Person();

p.stringKey(); // invoked stringKey
p[symbolKey](); // invoked symbolKey
p.computedKey(); // invoked computedKey

```

Class definitions also support getters and setter accessors. The syntax and behavior is identical to that of regular objects:

```

class Person {
  set name(newName) {
    this.name_ = newName;
  }

  get name() {
    return this.name_;
  }
}

let p = new Person();
p.name = 'Jake';
console.log(p.name); // Jake

```

Static Class Methods and Accessors

It is also possible to define methods on the class itself. These are intended to be used in situations where a function performs an action that is not centered on a specific instance and does not require a class instance to actually exist. Like prototype members, these are only ever created once per class.

A static class member is designated using the `static` keyword as a prefix inside the class definition. Inside static members, `this` refers to the class itself. All other conventions are identical to prototype members:

```

class Person {
  constructor() {
    // Everything added to 'this' will exist on each individual instance
    this.locate = () => console.log('instance', this);
  }

  // Defined on the class prototype object
  locate() {
    console.log('prototype', this);
  }

  // Defined on the class

```

```

    static locate() {
      console.log('class', this);
    }
  }

let p = new Person();

p.locate();           // instance, Person {}
Person.prototype.locate(); // prototype, {constructor: ... }
Person.locate();      // class, class Person {}

```

You may often find that these static class methods are useful as instance factories:

```

class Person {
  constructor(age) {
    this.age_ = age;
  }

  sayAge() {
    console.log(this.age_);
  }

  static create() {
    // Create and return a person instance with a random age
    return new Person(Math.floor(Math.random()*100));
  }
}

console.log(Person.create()); // Person { age_:... }

```

Non-Function Prototype and Class Members

Although the class definition does not explicitly support adding member data to prototypes or classes, outside the class definition there is nothing preventing you from adding them manually:

```

class Person {
  sayName() {
    console.log(`${Person.greeting} ${this.name}`);
  }
}

// Define data member on class
Person.greeting = 'My name is';

// Define data member on prototype
Person.prototype.name = 'Jake';

let p = new Person();
p.sayName(); // My name is Jake

```

NOTE *One main reason these are not explicitly allowed is that mutable data members in a shared object can be an antipattern. Generally, object instances should own the data that they reference from this.*

Iterator and Generator Methods

The class definition syntax allows for definition of generator methods on both the prototype and the class itself:

```
class Person {
  // define generator on prototype
  *createNicknameIterator() {
    yield 'Jack';
    yield 'Jake';
    yield 'J-Dog';
  }

  // define generator on class
  static *createJobIterator() {
    yield 'Butcher';
    yield 'Baker';
    yield 'Candlestick maker';
  }
}

let jobIter = Person.createJobIterator();
console.log(jobIter.next().value); // Butcher
console.log(jobIter.next().value); // Baker
console.log(jobIter.next().value); // Candlestick maker

let p = new Person();
let nicknameIter = p.createNicknameIterator();
console.log(nicknameIter.next().value); // Jack
console.log(nicknameIter.next().value); // Jake
console.log(nicknameIter.next().value); // J-Dog
```

Because generator methods are supported, it is possible to make a class instance iterable by adding a default iterator:

```
class Person {
  constructor() {
    this.nicknames = ['Jack', 'Jake', 'J-Dog'];
  }

  *[Symbol.iterator]() {
    yield *this.nicknames.entries();
  }
}

let p = new Person();
for (let [idx, nickname] of p) {
  console.log(nickname);
}
// Jack
// Jake
// J-Dog
```

Alternately, to merely return the iterator instance:

```
class Person {
  constructor() {
```

```

    this.nicknames = ['Jack', 'Jake', 'J-Dog'];
  }

  [Symbol.iterator]() {
    return this.nicknames.entries();
  }
}

let p = new Person();
for (let [idx, nickname] of p) {
  console.log(nickname);
}
// Jack
// Jake
// J-Dog

```

Inheritance

Earlier in the chapter, we covered the laborious details of implementing inheritance using ES5 mechanisms. One of the best additions in the ECMAScript 6 specification is native support for a class inheritance mechanism. Although it makes use of a new syntax, class inheritance still uses the prototype chain under the hood.

Inheritance Basics

ES6 classes support a single inheritance format. Using the `extends` keyword, you are able to inherit from anything that has a `[[Construct]]` property and a prototype. For the most part, this means inheriting from another class, but this also allows for backwards compatibility with function constructors:

```

class Vehicle {}

// Inherit from class
class Bus extends Vehicle {}

let b = new Bus();
console.log(b instanceof Bus);    // true
console.log(b instanceof Vehicle); // true

function Person() {}

// Inherit from function constructor
class Engineer extends Person {}

let e = new Engineer();
console.log(e instanceof Engineer); // true
console.log(e instanceof Person);   // true

```

Both class and prototype methods are carried down to the derived class. The value of `this` reflects the class or instance that is invoking the method:

```

class Vehicle {
  identifyPrototype(id) {
    console.log(id, this);
  }
}

```

```

    static identifyClass(id) {
      console.log(id, this);
    }
  }

class Bus extends Vehicle {}

let v = new Vehicle();
let b = new Bus();

b.identifyPrototype('bus'); // bus, Bus {}
v.identifyPrototype('vehicle'); // vehicle, Vehicle {}

Bus.identifyClass('bus'); // bus, class Bus {}
Vehicle.identifyClass('vehicle'); // vehicle, class Vehicle {}

```

NOTE *The extends keyword is valid inside class expressions, so `let Bar = class extends Foo {}` is perfectly valid syntax.*

Constructors, HomeObjects, and super()

Derived class methods have a reference to their prototype via the `super` keyword. This is only available for derived classes, and only available inside the constructor or inside static methods. `super` is used inside the constructor to control when to invoke the parent class constructor.

```

class Vehicle {
  constructor() {
    this.hasEngine = true;
  }
}

class Bus extends Vehicle {
  constructor() {
    // Cannot reference 'this' before super(), will throw ReferenceError

    super(); // same as super.constructor()

    console.log(this instanceof Vehicle); // true
    console.log(this); // Bus { hasEngine: true }
  }
}

new Bus();

```

`super` can also be used inside static methods to invoke static methods defined on the inherited class:

```

class Vehicle {
  static identify() {
    console.log('vehicle');
  }
}

```

```

    }

    class Bus extends Vehicle {
        static identify() {
            super.identify();
        }
    }

    Bus.identify(); // vehicle

```

NOTE *ES6 gives the constructor and static methods a reference to the internal `[[HomeObject]]`, which points to the object the method is defined upon. This pointer is assigned automatically and is only accessible internally inside the JavaScript engine. `super` will always be defined as the prototype of `[[HomeObject]]`.*

Things to note when using `super`:

- `super` can only be used in a derived class constructor or static method.

```

class Vehicle {
    constructor() {
        super();
        // SyntaxError: 'super' keyword unexpected
    }
}

```

- The `super` keyword cannot be referenced by itself; it must be either invoked as a constructor or used to reference a static method.

```

class Vehicle {}

class Bus extends Vehicle {
    constructor() {
        console.log(super);
        // SyntaxError: 'super' keyword unexpected here
    }
}

```

- Calling `super()` will invoke the parent class constructor and assign the resulting instance to `this`.

```

class Vehicle {}

class Bus extends Vehicle {
    constructor() {
        super();

        console.log(this instanceof Vehicle);
    }
}

new Bus(); // true

```

- `super()` behaves like a constructor function; you must manually pass arguments to it to pass them to the parent constructor.

```
class Vehicle {
  constructor(licensePlate) {
    this.licensePlate = licensePlate;
  }
}
```

```
class Bus extends Vehicle {
  constructor(licensePlate) {
    super(licensePlate);
  }
}
```

```
console.log(new Bus('1337H4X')); // Bus { licensePlate: '1337H4X' }
```

- If you decline to define a constructor function, `super()` will be invoked and all arguments passed to the derived class constructor.

```
class Vehicle {
  constructor(licensePlate) {
    this.licensePlate = licensePlate;
  }
}
```

```
class Bus extends Vehicle {}
```

```
console.log(new Bus('1337H4X')); // Bus { licensePlate: '1337H4X' }
```

- You cannot reference `this` inside the constructor before invoking `super()`.

```
class Vehicle {}
```

```
class Bus extends Vehicle {
  constructor() {
    console.log(this);
  }
}
```

```
new Bus();
// ReferenceError: Must call super constructor in derived class
// before accessing 'this' or returning from derived constructor
```

- If a class is derived from a parent class and you explicitly define a constructor, you must either invoke `super()` or return an object from the constructor.

```
class Vehicle {}
```

```
class Car extends Vehicle {}
```

```
class Bus extends Vehicle {
  constructor() {
    super();
  }
}
```



```
class Van extends Vehicle {
  constructor() {
    return {};
  }
}

console.log(new Car()); // Car {}
console.log(new Bus()); // Bus {}
console.log(new Van()); // {}
```

Abstract Base Classes

You may find a need to define a class that should be inherited from but not directly instantiated. Although ECMAScript does not explicitly support this, it is easy to implement using `new.target`, which informs you what was used in conjunction with the `new` keyword. You can prevent direct instantiation by checking that `new.target` is never the abstract base class:

```
// Abstract base class
class Vehicle {
  constructor() {
    console.log(new.target);
    if (new.target === Vehicle) {
      throw new Error('Vehicle cannot be directly instantiated');
    }
  }
}

// Derived class
class Bus extends Vehicle {}

new Bus(); // class Bus {}
new Vehicle(); // class Vehicle {}
// Error: Vehicle cannot be directly instantiated
```

It is also possible to require that a method be defined on a derived class by checking for it in the abstract base class constructor. Because prototype methods exist before the constructor is invoked, you can check for them on the `this` keyword:

```
// Abstract base class
class Vehicle {
  constructor() {
    if (new.target === Vehicle) {
      throw new Error('Vehicle cannot be directly instantiated');
    }

    if (!this.foo) {
      throw new Error('Inheriting class must define foo()');
    }

    console.log('success!');
  }
}
```

```

// Derived class
class Bus extends Vehicle {
  foo() {}
}

// Derived class
class Van extends Vehicle {}

new Bus(); // success!
new Van(); // Error: Inheriting class must define foo()

```

Inheriting from Built-in Types

ES6 classes offer seamless interoperability with existing built-in reference types, allowing you to extend them easily:

```

class SuperArray extends Array {
  shuffle() {
    // Fisher-Yates shuffle
    for (let i = this.length - 1; i > 0; i--) {
      const j = Math.floor(Math.random() * (i + 1));
      [this[i], this[j]] = [this[j], this[i]];
    }
  }
}

let a = new SuperArray(1, 2, 3, 4, 5);

console.log(a instanceof Array); // true
console.log(a instanceof SuperArray); // true

console.log(a); // [1, 2, 3, 4, 5]
a.shuffle();
console.log(a); // [3, 1, 4, 5, 2]

```

Some built-in types have methods defined in which a new object instance is returned. By default, the type of this object instance will match the type of the original instance:

```

class SuperArray extends Array {}

let a1 = new SuperArray(1, 2, 3, 4, 5);
let a2 = a1.filter(x => !!(x%2))

console.log(a1); // [1, 2, 3, 4, 5]
console.log(a2); // [1, 3, 5]
console.log(a1 instanceof SuperArray); // true
console.log(a2 instanceof SuperArray); // true

```

If you wish to override this, you can override the `Symbol.species` accessor, which is used to determine the class to be used to create the returned instance:

```

class SuperArray extends Array {
  static get [Symbol.species]() {
    return Array;
  }
}

```

```

    }

    let a1 = new SuperArray(1, 2, 3, 4, 5);
    let a2 = a1.filter(x => !(x%2))

    console.log(a1); // [1, 2, 3, 4, 5]
    console.log(a2); // [1, 3, 5]
    console.log(a1 instanceof SuperArray); // true
    console.log(a2 instanceof SuperArray); // false

```

Class Mixins

A common pattern in JavaScript is to bundle together behavior from several different classes into a single package. Although ES6 classes do not explicitly support inheriting from multiple classes, the feature offers extensibility that can be cleverly wielded to emulate such behavior.

NOTE *The `Object.assign()` method is designed to offer mixin behavior from object mixins. Implementing your own mixin expressions is only necessary when your mixins take the form of classes. If you only need to merge properties between multiple objects, prefer to use `Object.assign()`.*

The reference following the `extends` keyword is a JavaScript expression. Any syntax is valid there as long as it resolves to a class or function constructor. The expression is evaluated when the class definition is evaluated:

```

class Vehicle {}

function getParentClass() {
  console.log('evaluated expression');
  return Vehicle;
}

class Bus extends getParentClass() {}
// evaluated expression

```

A mixin pattern can be achieved by chaining multiple mixin elements inside the expression, which will resolve into a single class that can be inherited from. If a class `Person` needs to incorporate mixins `A`, `B`, and `C`, you will in some form architect a pattern that configures `B` to inherit from `A`, `C` to inherit from `B`, and `Person` to inherit from `C`—thereby joining all three mixins into the superclass. There are several strategies that can accomplish such a pattern.

One strategy is to define “nestable” functions that accept a superclass as a parameter, define the mixin class as a subclass of the parameter, and return that class. These mixins can be chained inside each other and provided as the superclass expression:

```

class Vehicle {}

let FooMixin = (Superclass) => class extends Superclass {

```

```

    foo() {
      console.log('foo');
    }
  };
let BarMixin = (Superclass) => class extends Superclass {
  bar() {
    console.log('bar');
  }
};
let BazMixin = (Superclass) => class extends Superclass {
  baz() {
    console.log('baz');
  }
};

class Bus extends FooMixin(BarMixin(BazMixin(Vehicle))) {}

let b = new Bus();
b.foo(); // foo
b.bar(); // bar
b.baz(); // baz

```

It is possible to flatten this nesting using a utility function:

```

class Vehicle {}

let FooMixin = (Superclass) => class extends Superclass {
  foo() {
    console.log('foo');
  }
};
let BarMixin = (Superclass) => class extends Superclass {
  bar() {
    console.log('bar');
  }
};
let BazMixin = (Superclass) => class extends Superclass {
  baz() {
    console.log('baz');
  }
};

function mix(BaseClass, ...Mixins) {
  return Mixins.reduce((accumulator, current) => current(accumulator), BaseClass);
}

class Bus extends mix(Vehicle, FooMixin, BarMixin, BazMixin) {}

let b = new Bus();
b.foo(); // foo
b.bar(); // bar
b.baz(); // baz

```

NOTE *Many JavaScript frameworks, most notably React, are moving away from mixin patterns and toward composition (in the form of extracting methods into separate classes and utilities, and incorporating those piecemeal without the use of inheritance). This reflects the well-known software principle of “composition over inheritance,” which is regarded by many to offer superior flexibility and code design.*

SUMMARY

Objects are created and augmented at any point during code execution, making objects into dynamic, rather than strictly defined, entities. The following patterns are used for the creation of objects:

- The factory pattern uses a simple function that creates an object, assigns properties and methods, and then returns the object. This pattern fell out of favor when the constructor pattern emerged.
- With the constructor pattern, it’s possible to define custom reference types that can be created using the `new` operator in the same way as built-in object instances are created. The constructor pattern does have a downside, however, in that none of its members are reused, including functions. Because functions can be written in a loosely typed manner, there’s no reason they cannot be shared by multiple object instances.
- The prototype pattern takes this into account, using the constructor’s `prototype` property to assign properties and methods that should be shared. The combination constructor/prototype pattern uses the constructor to define instance properties and the prototype pattern to define shared properties and methods.

Inheritance in JavaScript is implemented primarily using the concept of prototype chaining. Prototype chaining involves assigning a constructor’s prototype to be an instance of another type. In doing so, the subtype assumes all of the properties and methods of the supertype in a manner similar to class-based inheritance. The problem with prototype chaining is that all of the inherited properties and methods are shared among object instances, making it ill-suited for use on its own. The constructor stealing pattern avoids these issues, calling the supertype’s constructor from inside of the subtype’s constructor. This allows each instance to have its own properties but forces the types to be defined using only the constructor pattern. The most popular pattern of inheritance is combination inheritance, which uses prototype chaining to inherit shared properties and methods and uses constructor stealing to inherit instance properties.

There are also the following alternate inheritance patterns:

- Prototypal inheritance implements inheritance without the need for predefined constructors, essentially performing a shallow clone operation on a given object. The result of the operation then may be augmented further.

- Closely related is parasitic inheritance, which is a pattern for creating an object based on another object or some information, augmenting it, and returning it. This pattern has also been repurposed for use with combination inheritance to remove the inefficiencies related to the number of times the supertype constructor is called.
- Parasitic combination inheritance is considered the most efficient way to implement type-based inheritance.

New in ECMAScript 6 is the introduction of classes, which are largely a syntactical wrapper for existing prototype-based concepts. This syntax confers to the language the ability to elegantly define classes that are backwards compatible and can inherit from built-in or custom classes. Classes elegantly bridge the gap between object instances, object prototypes, and object classes.



Proxies and Reflect

WHAT'S IN THIS CHAPTER?

- Proxy fundamentals
- Proxy traps and reflect methods
- Proxy patterns

Freshly introduced in ECMAScript 6, proxies and reflection are totally new constructs that afford you the ability to intercept and shim additional behavior into fundamental operations within the language. More specifically, you can define a proxy object associated with a target object, and the proxy object can be used as an abstracted target object within which you can control what happens when various operations are performed before they actually reach the target object.

For developers approaching this subject for the first time, this is a fairly nebulous concept paired with a healthy corpus of new terminology. Working through multiple examples will help to cement your understanding.

NOTE *There is no analogue for proxies in ECMAScript versions prior to ES6. Because it is a fundamentally new language ability, many transpilers are unable to convert proxy behavior into earlier ECMAScript versions because replicating the behavior of a proxy is effectively impossible. Therefore, proxies and reflection are useful only in situations where native support is offered on 100 percent of platforms. It is possible to detect support for proxies and divert to fallback code as necessary, but this would lead to code duplication and is therefore discouraged.*

PROXY FUNDAMENTALS

As mentioned in the chapter introduction, a proxy behaves as an abstraction for a target object. In many ways, it is analogous to a C++ pointer in that it can be wielded as a stand-in for the target object it points to but is, in fact, totally separate from the target object. The target object can either be manipulated directly or through the proxy, but manipulating directly will circumvent the behavior that a proxy enables.

NOTE *There are key differences between ECMAScript proxies and C++ pointers that will be discussed later, but for introductory purposes pointers are a suitable conceptual building block.*

Creating a Passthrough Proxy

In its simplest form, a proxy can exist as nothing more than an abstracted target object. By default, all operations performed on a proxy object will be transparently propagated through to the target object. Therefore, you are able to use a proxy object in all the same ways and places that you would use the target object that the proxy object is associated with.

A proxy is created using the `Proxy` constructor. It requires you to provide both a target object and a handler object, without which a `TypeError` is thrown. For a simple passthrough proxy, using a simple object literal for the handler object will allow all operations to reach the target object unimpeded.

As shown here, all operations performed on the proxy will effectively be applied to the target object instead. The only perceptible difference is the identity of the proxy object.

```
const target = {
  id: 'target'
};

const handler = {};

const proxy = new Proxy(target, handler);

// The 'id' property will access the same value
console.log(target.id); // target
console.log(proxy.id);  // target

// Assignment to a target property changes both since
// both are accessing the same value.
target.id = 'foo';
console.log(target.id); // foo
console.log(proxy.id);  // foo

// Assignment to a proxy property changes both since
// this assignment is conferred to the target object.
proxy.id = 'bar';
console.log(target.id); // bar
console.log(proxy.id);  // bar
```



```

// The hasOwnProperty() method is effectively applied
// to the target in both cases.
console.log(target.hasOwnProperty('id')); // false
console.log(proxy.hasOwnProperty('id')); // false

// The instanceof operator is effectively applied
// to the target in both cases.
console.log(target instanceof Proxy); // false
console.log(proxy instanceof Proxy); // false

// Strict object equality can still be used to
// differentiate proxy from target.
console.log(target === proxy); // false

```

Defining Traps

The primary purpose of a proxy is to allow you to define *traps*, which behave as “fundamental operation interceptors” inside the handler object. Each handler object is made up of zero, one, or many traps, and each trap corresponds to a fundamental operation that can be directly or indirectly called on the proxy. When these fundamental operations are called on the proxy object, before being invoked on the target object, the proxy will invoke the trap function instead, allowing you to intercept and modify its behavior.

NOTE *The term “trap” is borrowed from the world of operating systems, where a trap is a synchronous interrupt in program flow that diverts processor execution to execute a subroutine before returning to the original program flow.*

For example, you are able to define a `get()` trap that is triggered each time any ECMAScript operation performs a `get()` in one form or another. Such a trap can be defined as follows:

```

const target = {
  foo: 'bar'
};

const handler = {
  // Traps are keyed by method name inside the handler object
  get() {
    return 'handler override';
  }
};

const proxy = new Proxy(target, handler);

```

When a `get()` operation is called on this proxy object, the trap function that is defined for `get()` will be invoked instead. Of course, `get()` is not a usable method on ECMAScript objects. The `get()` operation that is being trapped is shared between multiple operations that can be found in actual JavaScript code. Operations of the form `proxy[property]`, `proxy.property`, or `Object.create(proxy)[property]` will all use the fundamental operation `get()` to retrieve the property,

and therefore all of these will invoke the trap function instead when they are used on the proxy. Only the proxy will use the trap handler functions; these operations will behave normally when used with the target object.

```
const target = {
  foo: 'bar'
};

const handler = {
  // Traps are keyed by method name inside the handler object
  get() {
    return 'handler override';
  }
};

const proxy = new Proxy(target, handler);

console.log(target.foo);           // bar
console.log(proxy.foo);           // handler override

console.log(target['foo']);        // bar
console.log(proxy['foo']);         // handler override

console.log(Object.create(target)['foo']); // bar
console.log(Object.create(proxy)['foo']);  // handler override
```

Trap Parameters and the Reflect API

All traps have access to parameters that will allow you to fully recreate the original behavior of the trapped method. For example, the `get()` method receives a reference to the target object, the property being looked up, and a reference to the proxy object.

```
const target = {
  foo: 'bar'
};

const handler = {
  get(trapTarget, property, receiver) {
    console.log(trapTarget === target);
    console.log(property);
    console.log(receiver === proxy);
  }
};

const proxy = new Proxy(target, handler);

proxy.foo;
// true
// foo
// true
```

Thus, it is possible to define a trap handler that wholly recreates the behavior of the method being trapped:

```
const target = {
  foo: 'bar'
};

const handler = {
  get(trapTarget, property, receiver) {
    return trapTarget[property];
  }
};

const proxy = new Proxy(target, handler);

console.log(proxy.foo); // bar
console.log(target.foo); // bar
```

Such a tactic can be implemented for all traps, but not all trap behavior is as simple to recreate as `get()`; therefore, this is an impractical strategy. Instead of manually implementing the contents of the trapped method, the original behavior of the trapped method is wrapped inside an identically named method on the global `Reflect` object.

Every method that can be trapped inside a handler object has a corresponding `Reflect` API method. This method has an identical name and function signature, and performs the exact behavior that the trapped method is intercepting. Therefore, it is possible to define a passthrough proxy using only the `Reflect` API:

```
const target = {
  foo: 'bar'
};

const handler = {
  get() {
    return Reflect.get(...arguments);
  }
};

const proxy = new Proxy(target, handler);

console.log(proxy.foo); // bar
console.log(target.foo); // bar
```

Alternately, in a more succinct format:

```
const target = {
  foo: 'bar'
};

const handler = {
  get: Reflect.get
};

const proxy = new Proxy(target, handler);

console.log(proxy.foo); // bar
console.log(target.foo); // bar
```

If you wish to create a true passthrough proxy that traps every available method and forwards each one to its corresponding Reflect API function, defining an explicit handler object is not required:

```
const target = {
  foo: 'bar'
};

const proxy = new Proxy(target, Reflect);

console.log(proxy.foo); // bar
console.log(target.foo); // bar
```

The Reflect API allows you to modify the trapped method with minimal boilerplate code. For example, the following decorates the return value whenever a certain property is accessed:

```
const target = {
  foo: 'bar',
  baz: 'qux'
};

const handler = {
  get(trapTarget, property, receiver) {
    let decoration = '';
    if (property === 'foo') {
      decoration = '!!!';
    }

    return Reflect.get(...arguments) + decoration;
  }
};

const proxy = new Proxy(target, handler);

console.log(proxy.foo); // bar!!!
console.log(target.foo); // bar

console.log(proxy.baz); // qux
console.log(target.baz); // qux
```

Trap Invariants

Traps give you a broad ability to change how nearly any fundamental method behaves, but they are not without restriction. Each trapped method is aware of the target object context and trap function signature, and the behavior of the trap handler function must obey the “trap invariants” as specified in the ECMAScript specification. Trap invariants vary by method, but in general they will prevent the trap definition from exhibiting any grossly unexpected behavior.

For example, if a target object has a non-configurable and non-writable data property, a `TypeError` will be thrown if you attempt to return a value from the trap that is different from the target object’s property:

```
const target = {};
Object.defineProperty(target, 'foo', {
  configurable: false,
```

```

    writable: false,
    value: 'bar'
  });

  const handler = {
    get() {
      return 'qux';
    }
  };

  const proxy = new Proxy(target, handler);

  console.log(proxy.foo);
  // TypeError

```

Revocable Proxies

You may find a need for disabling the association between the proxy object and the target object. For a normal proxy created with `new Proxy()`, this association lasts the lifetime of the proxy object.

`Proxy` also exposes a `revocable()` method, which provides you with an additional `revoke` function that can be called to disassociate the proxy object from the target object. Revoking the proxy is irreversible. Furthermore, the `revoke` function is idempotent and will not have further effect if called multiple times. Any method called on a proxy after it is revoked will throw a `TypeError`.

The `revoke` function can be captured upon proxy instantiation:

```

const target = {
  foo: 'bar'
};

const handler = {
  get() {
    return 'intercepted';
  }
};

const { proxy, revoke } = Proxy.revocable(target, handler);

console.log(proxy.foo); // intercepted
console.log(target.foo); // bar

revoke();

console.log(proxy.foo); // TypeError

```

Utility of the Reflect API

There are a handful of reasons to favor the `Reflect` API in certain situations.

Reflect API vs. Object API

When diving into the Reflect API, remember:

1. The Reflect API is not limited to trap handler
2. Most Reflect API methods have an analogue on the Object type.

In general, the Object methods are geared for general application use, and the Reflect methods are geared for fine-tuned object control and manipulation.

Status Flags

Many Reflect methods return a Boolean, indicating if the operation they intend to perform will be successful or not. In certain situations, this is more useful than how other Reflect API methods behave, which will either return the modified object or throw an error (depending on the method). For example, you can use the Reflect API to perform the following refactor:

```
// Initial code

const o = {};

try {
  Object.defineProperty(o, 'foo', 'bar');
  console.log('success');
} catch(e) {
  console.log('failure');
}
```

In the event of a problem with defining the new property, `Reflect.defineProperty` will return `false` instead of throwing an error, enabling you to do the following:

```
// Refactored code

const o = {};

if(Object.defineProperty(o, 'foo', 'bar')) {
  console.log('success');
} else {
  console.log('failure');
}
```

The following Reflect methods provide you with status flags:

- `Reflect.defineProperty`
- `Reflect.preventExtensions`
- `Reflect.setPrototypeOf`
- `Reflect.set`
- `Reflect.deleteProperty`

Supplanting Operators with First-Class Functions

Several Reflect methods offer behavior that is available only via operators:

- `Reflect.get()` accesses behavior that is only available otherwise via object property access.
- `Reflect.set()` accesses behavior that is only available otherwise via the `=` assignment operator.
- `Reflect.has()` accesses behavior that is only available otherwise via the `in` operator or `with()`.
- `Reflect.deleteProperty()` accesses behavior that is only available otherwise via the `delete` operator.
- `Reflect.construct()` accesses behavior that is only available otherwise via the `new` operator.

Safe Function Application

When invoking a function using the `apply` method, there is a small possibility that the function being called defines its own `apply` property. To circumvent this, it is possible to pluck the `apply` method off the `Function` prototype, as follows:

```
Function.prototype.apply.call(myFunc, thisVal, argumentList);
```

This nightmarish line of code can be avoided and fully replicated using `Reflect.apply`:

```
Reflect.apply(myFunc, thisVal, argumentsList);
```

Proxying a Proxy

Proxies are capable of intercepting Reflect API operations, and this means that it is entirely possible to create a proxy of a proxy. This allows you to build multiple layers of indirection on top of a singular target object:

```
const target = {
  foo: 'bar'
};

const firstProxy = new Proxy(target, {
  get() {
    console.log('first proxy');
    return Reflect.get(...arguments);
  }
});

const secondProxy = new Proxy(firstProxy, {
  get() {
    console.log('second proxy');
    return Reflect.get(...arguments);
  }
});

console.log(secondProxy.foo);
// second proxy
// first proxy
// bar
```

Proxy Considerations and Shortcomings

Proxies are a new API built upon existing ECMAScript infrastructure, and therefore their implementation was best-effort. For the most part, proxies work very well as a virtualization layer for objects. Nevertheless, proxies cannot always seamlessly integrate with existing ECMAScript constructs in certain scenarios.

'this' Inside a Proxy

One potential source of trouble with proxies is the value of `this`. As you might expect, the `this` value inside a method will respect the object upon which it was called:

```
const target = {
  thisValEqualsProxy() {
    return this === proxy;
  }
}

const proxy = new Proxy(target, {});

console.log(target.thisValEqualsProxy()); // false
console.log(proxy.thisValEqualsProxy()); // true
```

Intuitively, this should make perfect sense: Any method called on a proxy, `proxy.outerMethod()`, which in turn calls another method inside its function body, `this.innerMethod()`, should effectively be invoking `proxy.innerMethod()`. In most cases, this is certainly the expected behavior; however, if your target relies on object identity, you may encounter unexpected issues.

Recall the `WeakMap` private variable implementation from the *Collection Reference Types* chapter, an abridged version of which is displayed here:

```
const wm = new WeakMap();

class User {
  constructor(userId) {
    wm.set(this, userId);
  }

  set id(userId) {
    wm.set(this, userId);
  }

  get id() {
    return wm.get(this);
  }
}
```

Because this implementation relies on the object identity of the `User` instance, it will encounter problems when the user instance is proxied:

```
const user = new User(123);
console.log(user.id); // 123

const userInstanceProxy = new Proxy(user, {});
console.log(userInstanceProxy.id); // undefined
```

The user instance is initially being keyed in the weak map with the target object, but the proxy is attempting to retrieve that instance with the *proxy* object. The solution to such a problem is to reconfigure the proxying such that the initial key insertion is done with a proxy instance—a feat that can be accomplished by proxying the User class itself, and instantiating a proxy of the class:

```
const UserClassProxy = new Proxy(User, {});
const proxyUser = new UserClassProxy(456);
console.log(proxyUser.id);
```

Proxies and Internal Slots

Often, you will find that instances of built-in reference types can work alongside proxies seamlessly, as is the case with `Array`. However, some ECMAScript built-in types can rely on mechanisms that proxies cannot control. The result of this is that some methods on a wrapped instance will flat out not work properly.

The canonical example of this is the `Date` type. Per the ECMAScript specification, `Date` types rely on the existence of an “internal slot” named `[[NumberData]]` on the `this` value when executing methods. Because the internal slot does not exist on the proxy, and because these internal slot values are not accessed via the normal `get` and `set` operations that a proxy could otherwise intercept and redirect to the target, the method will throw a `TypeError`:

```
const target = new Date();
const proxy = new Proxy(target, {});

console.log(proxy instanceof Date); // true

proxy.getDate(); // TypeError: 'this' is not a Date object
```

PROXY TRAPS AND REFLECT METHODS

Proxies are able to trap thirteen different fundamental operations. Each has its own entry in the Reflect API, parameters, associated ECMAScript operations, and invariants.

As demonstrated earlier, several different JavaScript operations may invoke the same trap handler. However, for any single operation that is performed on a proxy object, only one trap handler will ever be called; there is no overlap of trap coverage.

All traps will also intercept their corresponding Reflect API operations if they are invoked on the proxy.

get()

The `get()` trap is called inside operations that retrieve a property value. Its corresponding Reflect API method is `Reflect.get()`.

```
const myTarget = {};

const proxy = new Proxy(myTarget, {
  get(target, property, receiver) {
    console.log('get()');
  }
});
```

```
        return Reflect.get(...arguments)
    }
});

proxy.foo;
// get()
```

Return value

The return value is unrestricted.

Intercepted operations

```
proxy.property
proxy[property]
Object.create(proxy) [property]
Reflect.get(proxy, property, receiver)
```

Trap handler parameters

target: Target object

property: String key property being referenced on target object

receiver: Proxy object or object that inherits from proxy object

Trap invariants

If `target.property` is non-writable and non-configurable, the handler return value must match `target.property`.

If `target.property` is non-configurable and has `undefined` as its `[[Get]]` attribute, the handler return value must also be `undefined`.

set()

The `set()` trap is called inside operations that assign a property value. Its corresponding Reflect API method is `Reflect.set()`.

```
const myTarget = {};

const proxy = new Proxy(myTarget, {
  set(target, property, value, receiver) {
    console.log('set()');
    return Reflect.set(...arguments)
  }
});

proxy.foo = 'bar';
// set()
```

Return value

A return value of `true` indicates success; a return value of `false` indicates failure, and in strict mode will throw a `TypeError`.

Intercepted operations

```
proxy.property = value
proxy[property] = value
Object.create(proxy)[property] = value
Reflect.set(proxy, property, value, receiver)
```

Trap handler parameters

target: Target object

property: String key property being referenced on target object

value: The value being assigned to property

receiver: The original assignment recipient object

Trap invariants

If `target.property` is non-writable and non-configurable, the target property value cannot be altered.

If `target.property` is non-configurable and has `undefined` as its `[[Set]]` attribute, the target property value cannot be altered.

Returning `false` from the handler will throw a `TypeError` in strict mode.

has()

The `has()` trap is called inside the `in` operator. Its corresponding Reflect API method is `Reflect.has()`.

```
const myTarget = {};

const proxy = new Proxy(myTarget, {
  has(target, property) {
    console.log('has() ');
    return Reflect.has(...arguments)
  }
});

'foo' in proxy;
// has()
```

Return value

`has()` must return a Boolean indicating if the property is present or not. Non-Boolean return values will be coerced into a Boolean.

Intercepted operations

```
property in proxy
property in Object.create(proxy)
with(proxy) {(property);}
Reflect.has(proxy, property)
```

Trap handler parameters

target: Target object
property: String key property being referenced on target object

Trap invariants

If an own `target.property` exists and is non-configurable, the handler must return `true`.
If an own `target.property` exists and the target object is non-extensible, the handler must return `true`.

defineProperty()

The `defineProperty()` trap is called inside `Object.defineProperty()`. Its corresponding Reflect API method is `Reflect.defineProperty()`.

```
const myTarget = {};

const proxy = new Proxy(myTarget, {
  defineProperty(target, property, descriptor) {
    console.log('defineProperty()');
    return Reflect.defineProperty(...arguments)
  }
});

Object.defineProperty(proxy, 'foo', { value: 'bar' });
// defineProperty()
```

Return value

`defineProperty()` must return a Boolean indicating if the property was successfully defined or not. Non-Boolean return values will be coerced into a Boolean.

Intercepted operations

```
Object.defineProperty(proxy, property, descriptor)
Reflect.defineProperty(proxy, property, descriptor)
```

Trap handler parameters

target: Target object

property: String key property being referenced on target object

descriptor: Object containing optional definitions for enumerable, configurable, writable, value, get, or set

Trap invariants

If the target object is non-extensible, properties cannot be added.

If the target object has a configurable property, a non-configurable property of the same key cannot be added.

If the target object has a non-configurable property, a configurable property of the same key cannot be added.

getOwnPropertyDescriptor()

The `getOwnPropertyDescriptor()` trap is called inside `Object.getOwnPropertyDescriptor()`. Its corresponding Reflect API method is `Reflect.getOwnPropertyDescriptor()`.

```
const myTarget = {};

const proxy = new Proxy(myTarget, {
  getOwnPropertyDescriptor(target, property) {
    console.log('getOwnPropertyDescriptor()');
    return Reflect.getOwnPropertyDescriptor(...arguments)
  }
});

Object.getOwnPropertyDescriptor(proxy, 'foo');
// getOwnPropertyDescriptor()
```

Return value

`getOwnPropertyDescriptor()` must return an object, or undefined if the property does not exist.

Intercepted operations

```
property in proxy
property in Object.create(proxy)
with(proxy) { (property); }
Reflect.has(proxy, property)
```

Trap handler parameters

target: Target object

property: String key property being referenced on target object

Trap invariants

If an own `target.property` exists and is non-configurable, the handler must return an object to indicate that the property exists.

If an own `target.property` exists and is configurable, the handler cannot return an object indicating that the property is configurable.

If an own `target.property` exists and `target` is non-extensible, the handler must return an object to indicate that the property exists.

If `target.property` does not exist and `target` is non-extensible, the handler must return `undefined` to indicate that the property does not exist.

If `target.property` does not exist, the handler cannot return an object indicating that the property is configurable.

`deleteProperty()`

The `deleteProperty()` trap is called inside the `delete` operator. Its corresponding Reflect API method is `Reflect.deleteProperty()`.

```
const myTarget = {};  
  
const proxy = new Proxy(myTarget, {  
  deleteProperty(target, property) {  
    console.log('deleteProperty() ');  
    return Reflect.deleteProperty(...arguments)  
  }  
});  
  
delete proxy.foo  
// deleteProperty()
```

Return value

`deleteProperty()` must return a Boolean indicating if the property was successfully deleted or not. Non-Boolean return values will be coerced into a Boolean.

Intercepted operations

```
delete proxy.property  
  
delete proxy[property]  
  
Reflect.deleteProperty(proxy, property)
```

Trap handler parameters

target: Target object

property: String key property being referenced on target object

Trap invariants

If an own `target.property` exists and is non-configurable, the handler cannot delete the property.

ownKeys()

The `ownKeys()` trap is called inside `Object.keys()` and similar methods. Its corresponding Reflect API method is `Reflect.ownKeys()`.

```
const myTarget = {};

const proxy = new Proxy(myTarget, {
  ownKeys(target) {
    console.log('ownKeys()');
    return Reflect.ownKeys(...arguments)
  }
});

Object.keys(proxy);
// ownKeys()
```

Return value

`ownKeys()` must return an enumerable object that contains either strings or symbols.

Intercepted operations

```
Object.getOwnPropertyNames(proxy)
Object.getOwnPropertySymbols(proxy)
Object.keys(proxy)
Reflect.ownKeys(proxy)
```

Trap handler parameters

target: Target object

Trap invariants

The returned enumerable object must contain all non-configurable own properties of `target`.

If `target` is non-extensible, the returned enumerable object must exactly contain the own property keys of `target`.

getPrototypeOf()

The `getPrototypeOf()` trap is called inside `Object.getPrototypeOf()`. Its corresponding Reflect API method is `Reflect.getPrototypeOf()`.

```
const myTarget = {};
```

```
const proxy = new Proxy(myTarget, {
  getPrototypeOf(target) {
    console.log('getPrototypeOf()');
    return Reflect.getPrototypeOf(...arguments)
  }
});

Object.getPrototypeOf(proxy);
// getPrototypeOf()
```

Return value

`getPrototypeOf()` must return an object or null.

Intercepted operations

```
Object.getPrototypeOf(proxy)
Reflect.getPrototypeOf(proxy)
proxy.__proto__
Object.prototype.isPrototypeOf(proxy)
proxy instanceof Object
```

Trap handler parameters

target: Target object

Trap invariants

If `target` is non-extensible, the only valid return value of `Object.getPrototypeOf(proxy)` is the value returned from `Object.getPrototypeOf(target)`.

setPrototypeOf()

The `setPrototypeOf()` trap is called inside `Object.setPrototypeOf()`. Its corresponding Reflect API method is `Reflect.setPrototypeOf()`.

```
const myTarget = {};

const proxy = new Proxy(myTarget, {
  setPrototypeOf(target, prototype) {
    console.log('setPrototypeOf()');
    return Reflect.setPrototypeOf(...arguments)
  }
});

Object.setPrototypeOf(proxy, Object);
// setPrototypeOf()
```

Return value

`setPrototypeOf()` must return a Boolean indicating if the prototype assignment was successful or not. Non-Boolean return values will be coerced into a Boolean.

Intercepted operations

```
Object.setPrototypeOf(proxy)
```

```
Reflect.setPrototypeOf(proxy)
```

Trap handler parameters

target: Target object

prototype: The intended replacement prototype for `target`, or `null` if this is to be a top-level prototype

Trap invariants

If `target` is non-extensible, the only valid `prototype` parameter is the value returned from `Object.getPrototypeOf(target)`.

isExtensible()

The `isExtensible()` trap is called inside `Object.isExtensible()`. Its corresponding Reflect API method is `Reflect.isExtensible()`.

```
const myTarget = {};

const proxy = new Proxy(myTarget, {
  isExtensible(target) {
    console.log('isExtensible()');
    return Reflect.isExtensible(...arguments)
  }
});

Object.isExtensible(proxy);
// isExtensible()
```

Return value

`isExtensible()` must return a Boolean indicating if the prototype assignment was successful or not. Non-Boolean return values will be coerced into a Boolean.

Intercepted operations

```
Object.isExtensible(proxy)
```

```
Reflect.isExtensible(proxy)
```

Trap handler parameters

target: Target object

Trap invariants

If `target` is extensible, the handler must return `true`.

If `target` is non-extensible, the handler must return `false`.

preventExtensions()

The `preventExtensions()` trap is called inside `Object.preventExtensions()`. Its corresponding Reflect API method is `Reflect.preventExtensions()`.

```
const myTarget = {};  
  
const proxy = new Proxy(myTarget, {  
  preventExtensions(target) {  
    console.log('preventExtensions()');  
    return Reflect.preventExtensions(...arguments)  
  }  
});  
  
Object.preventExtensions(proxy);  
// preventExtensions()
```

Return value

`preventExtensions()` must return a Boolean indicating if `target` is already non-extensible. Non-Boolean return values will be coerced into a Boolean.

Intercepted operations

```
Object.preventExtensions(proxy)  
Reflect.preventExtensions(proxy)
```

Trap handler parameters

target: Target object

Trap invariants

If `Object.isExtensible(proxy)` is `false`, the handler must return `true`.

apply()

The `apply()` trap is called on function calls. Its corresponding Reflect API method is `Reflect.apply()`.

```
const myTarget = () => {};
```

```

const proxy = new Proxy(myTarget, {
  apply(target, thisArg, ...argumentsList) {
    console.log('apply()');
    return Reflect.apply(...arguments)
  }
});

proxy();
// apply()

```

Return value

The return value is unrestricted.

Intercepted operations

```

proxy(...argumentsList)

Function.prototype.apply(thisArg, argumentsList)

Function.prototype.call(thisArg, ...argumentsList)

Reflect.apply(target, thisArgument, argumentsList)

```

Trap handler parameters

target: Target object

thisArg: this argument for the function call

argumentsList: List of arguments for the function call

Trap invariants

target must be a function object.

construct()

The `construct()` trap is called inside the `new` operator. Its corresponding Reflect API method is `Reflect.construct()`.

```

const myTarget = function() {};

const proxy = new Proxy(myTarget, {
  construct(target, argumentsList, newTarget) {
    console.log('construct()');
    return Reflect.construct(...arguments)
  }
});

new proxy;
// construct()

```

Return value

`construct()` must return an object.

Intercepted operations

```
new proxy(...argumentsList)
Reflect.construct(target, argumentsList, newTarget)
```

Trap handler parameters

target: Target constructor

argumentsList: List of arguments passed to the target constructor

newTarget: The originally called constructor

Trap invariants

target must be able to be used as a constructor.

PROXY PATTERNS

The Proxy API allows you to introduce some incredibly useful patterns into your code.

Tracking Property Access

The nature of `get`, `set`, and `has` affords you total insight into when object properties are being accessed and inspected. If you provide a trapped proxy to an object throughout your application, you will be able to see exactly when and where this object is accessed:

```
const user = {
  name: 'Jake'
};

const proxy = new Proxy(user, {
  get(target, property, receiver) {
    console.log('Getting ${property}');

    return Reflect.get(...arguments);
  },
  set(target, property, value, receiver) {
    console.log('Setting ${property}=${value}');

    return Reflect.set(...arguments);
  }
});

proxy.name; // Getting name
proxy.age = 27; // Setting age=27
```

Hidden Properties

The innards of proxies are totally hidden to remote code so it is very easy to conceal the existence of properties on the target object. For example:

```
const hiddenProperties = ['foo', 'bar'];
const targetObject = {
  foo: 1,
  bar: 2,
  baz: 3
};
const proxy = new Proxy(targetObject, {
  get(target, property) {
    if (hiddenProperties.includes(property)) {
      return undefined;
    } else {
      return Reflect.get(...arguments);
    }
  },
  has(target, property) {
    if (hiddenProperties.includes(property)) {
      return false;
    } else {
      return Reflect.has(...arguments);
    }
  }
});

// get()
console.log(proxy.foo); // undefined
console.log(proxy.bar); // undefined
console.log(proxy.baz); // 3

// has()
console.log('foo' in proxy); // false
console.log('bar' in proxy); // false
console.log('baz' in proxy); // true
```

Property Validation

Because all assignments must go through the `set()` trap, you can allow or reject assignments based on the content of the intended value:

```
const target = {
  onlyNumbersGoHere: 0
};

const proxy = new Proxy(target, {
  set(target, property, value) {
    if (typeof value !== 'Number') {
      return false;
    } else {
      return Reflect.set(...arguments);
    }
  }
});
```

```

proxy.onlyNumbersGoHere = 1;
console.log(proxy.onlyNumbersGoHere); // 1
proxy.onlyNumbersGoHere = '2';
console.log(proxy.onlyNumbersGoHere); // 1

```

Function and Constructor Parameter Validation

In the same way that object properties can be validated and protected, function and constructor parameters are also available for vetting. For example, a function can ensure that it is only provided values of a certain type:

```

function median(...nums) {
  return nums.sort()[Math.floor(nums.length / 2)];
}

const proxy = new Proxy(median, {
  apply(target, thisArg, ...argumentsList) {
    for (const arg of argumentsList) {
      if (typeof arg !== 'number') {
        throw 'Non-number argument provided';
      }
    }
    return Reflect.apply(...arguments);
  }
});

console.log(proxy(4, 7, 1)); // 4
console.log(proxy(4, '7', 1));
// Error: Non-number argument provided

```

Similarly, a constructor can enforce the presence of constructor parameters:

```

class User {
  constructor(id) {
    this.id_ = id;
  }
}

const proxy = new Proxy(User, {
  construct(target, argumentsList, newTarget) {
    if (argumentsList[0] === undefined) {
      throw 'User cannot be instantiated without id';
    } else {
      return Reflect.construct(...arguments);
    }
  }
});

new proxy(1);

new proxy();
// Error: User cannot be instantiated without id

```

Data Binding and Observables

Proxying allows you to intertwine the existence of various parts of the runtime that would otherwise be separate. This allows for a wide variety of patterns that enable different bits of code to interact with one another.

For example, a proxied class can be bound to a global collection of instances so that every created instance is added to that collection:

```
const userList = [];  
  
class User {  
  constructor(name) {  
    this.name_ = name;  
  }  
}  
  
const proxy = new Proxy(User, {  
  construct() {  
    const newUser = Reflect.construct(...arguments);  
    userList.push(newUser);  
    return newUser;  
  }  
});  
  
new proxy('John');  
new proxy('Jacob');  
new proxy('Jingleheimerschmidt');  
  
console.log(userList); // [User {}, User {}, User {}]
```

Alternately, a collection can be bound to an emitter, which will fire each time a new instance is inserted:

```
const userList = [];  
  
function emit(newValue) {  
  console.log(newValue);  
}  
  
const proxy = new Proxy(userList, {  
  set(target, property, value, receiver) {  
    const result = Reflect.set(...arguments);  
    if (result) {  
      emit(Reflect.get(target, property, receiver));  
    }  
    return result;  
  }  
});  
  
proxy.push('John');  
// John  
proxy.push('Jacob');  
// Jacob
```

SUMMARY

Proxies are one of the more exciting and dynamic additions in the ECMAScript 6 specification. Although they have no backwards compilation support, they enable an entirely new field of metaprogramming and abstraction that was not previously available.

At a high level, proxies are a transparent virtualization of a real JavaScript object. When a proxy is created, you are able to define a handler object containing *traps*, which are points of interception that will be encountered by nearly every fundamental JavaScript operator and method. These trap handlers allow you to modify how these fundamental methods operate, although they are bound by *trap invariants*.

Alongside proxies is the Reflect API, which offers a suite of methods that identically encapsulate the behavior each trap is intercepting. The Reflect API can be thought of as a collection of fundamental operations that are the building blocks of nearly all JavaScript object APIs.

The utility of proxies is nearly unbounded, and it allows the developer to wield elegant new patterns such as (but certainly not limited to) tracking property access, hiding properties, preventing modification or deletion of properties, function parameter validation, constructor parameter validation, data binding, and observables.

10

Functions

WHAT'S IN THIS CHAPTER?

- Function expressions, function declarations, and arrow functions
- Default parameters and spread operators
- Recursion with functions
- Private variables using closures

WROX.COM DOWNLOADS FOR THIS CHAPTER

Please note that all the code examples for this chapter are available as a part of this chapter's code download on the book's website at www.wrox.com/go/projavascript4e on the Download Code tab.

Some of the most interesting parts of ECMAScript are its functions, primarily because functions actually are objects. Each function is an instance of the `Function` type that has properties and methods just like any other reference type. Because functions are objects, function names are simply pointers to function objects and are not necessarily tied to the function itself. Functions are typically defined using function-declaration syntax, as in this example:

```
function sum (num1, num2) {  
    return num1 + num2;  
}
```

In this code, a variable `sum` is defined and initialized to be a function. Note that there is no name included after the `function` keyword because it's not needed—the function can be referenced by the variable `sum`. Also note that there is no semicolon after the end of the function definition.

The function-declaration syntax is almost exactly equivalent to using a function expression, such as this:

```
let sum = function(num1, num2) {  
  return num1 + num2;  
};
```

Note that there is a semicolon after the end of the function, just as there would be after any variable initialization.

Another way to define a function that is quite similar to a function expression is to use the “arrow” function syntax, such as this:

```
let sum = (num1, num2) => {  
  return num1 + num2;  
};
```

The final way to define functions is to use the `Function` constructor, which accepts any number of arguments. The last argument is always considered to be the function body, and the previous arguments enumerate the new function’s arguments. Consider this example:

```
let sum = new Function("num1", "num2", "return num1 + num2"); // not recommended
```

This syntax is not recommended because it causes a double interpretation of the code (once for the regular ECMAScript code and once for the strings that are passed into the constructor) and thus can affect performance. However, it’s important to think of functions as objects and function names as pointers—this syntax is great at representing that concept.

NOTE *There are subtle but important differences between these different ways to instantiate a function object that will be discussed later in the chapter. Nevertheless, all of them are invoked in an identical way.*

ARROW FUNCTIONS

New in ECMAScript 6 is the capability to define a function expression using the fat-arrow syntax. For the most part, arrow functions instantiate function objects that behave in the same manner as their formal function expression counterparts. Anywhere a function expression can be used, an arrow function can also be used:

```
let arrowSum = (a, b) => {  
  return a + b;  
};  
  
let functionExpressionSum = function(a, b) {  
  return a + b;  
};  
  
console.log(arrowSum(5, 8)); // 13  
console.log(functionExpressionSum(5, 8)); // 13
```

Arrow functions are exceptionally useful in inline situations where they offer a more succinct syntax:

```
let ints = [1, 2, 3];

console.log(ints.map(function(i) { return i + 1; })); // [2, 3, 4]
console.log(ints.map((i) => { return i + 1 })); // [2, 3, 4]
```

Arrow functions do not require the parentheses if you only want to use a single parameter. If you want to have zero parameters, or more than one parameter, parentheses are required:

```
// Both are valid
let double = (x) => { return 2 * x; };
let triple = x => { return 3 * x; };

// Zero parameters require an empty pair of parentheses
let getRandom = () => { return Math.random(); };

// Multiple parameters require parentheses
let sum = (a, b) => { return a + b; };

// Invalid syntax:
let multiply = a, b => { return a * b; };
```

Arrow functions also do not require curly braces, but choosing to not use them changes the behavior of the function. Using the curly braces is called the "block body" syntax and behaves in the same way as a normal function expression in that multiple lines of code can exist inside the arrow function as they would for a normal function expression. If you omit the curly braces, you are using the "concise body" syntax and are limited to a single line of code, such as an assignment or expression. The value of this line will implicitly return, as demonstrated here:

```
// Both are valid and will return the value
let double = (x) => { return 2 * x; };
let triple = (x) => 3 * x;

// Assignment is allowed
let value = {};
let setName = (x) => x.name = "Matt";
setName(value);
console.log(value.name); // "Matt"

// Invalid syntax:
let multiply = (a, b) => return a * b;
```

Arrow functions, although syntactically succinct, are not suited in several situations. They do not allow the use of arguments, super, or new.target, and cannot be used as a constructor. Additionally, function objects created with the arrow syntax do not have a prototype defined.

FUNCTION NAMES

Because function names are simply pointers to functions, they act like any other variable containing a pointer to an object. This means it's possible to have multiple names for a single function, as in this example:

```
function sum(num1, num2) {
  return num1 + num2;
}
```

```

console.log(sum(10, 10));           // 20

let anotherSum = sum;
console.log(anotherSum(10, 10));    // 20

sum = null;
console.log(anotherSum(10, 10));    // 20

```

This code defines a function named `sum()` that adds two numbers together. A variable, `anotherSum`, is declared and set equal to `sum`. Note that using the function name without parentheses accesses the function pointer instead of executing the function. At this point, both `anotherSum` and `sum` point to the same function, meaning that `anotherSum()` can be called and a result returned. When `sum` is set to `null`, it severs its relationship with the function, although `anotherSum()` can still be called without any problems.

All function objects in ECMAScript 6 expose a read-only `name` property that describes the function. In many cases, this will just be the function identifier, or the stringified variable name that references the function. If a function is unnamed, it will be reported as such. If it is created using the function constructor, it will be identified as “anonymous”:

```

function foo() {}
let bar = function() {};
let baz = () => {};

console.log(foo.name);           // foo
console.log(bar.name);           // bar
console.log(baz.name);           // baz
console.log(() => {}).name;       // (empty string)
console.log((new Function()).name); // anonymous

```

If a function is a getter, a setter, or instantiated using `bind()`, a prefix will be prepended to identify it as such:

```

function foo() {}

console.log(foo.bind(null).name); // bound foo

let dog = {
  years: 1,
  get age() {
    return this.years;
  },
  set age(newAge) {
    this.years = newAge;
  }
}

let propertyDescriptor = Object.getOwnPropertyDescriptor(dog, 'age');
console.log(propertyDescriptor.get.name); // get age
console.log(propertyDescriptor.set.name); // set age

```

UNDERSTANDING ARGUMENTS

Function arguments in ECMAScript don't behave in the same way as function arguments in most other languages. An ECMAScript function doesn't care how many arguments are passed in, nor does it care about the data types of those arguments. Just because you define a function to accept two arguments doesn't mean you can pass in only two arguments. You could pass in one or three or none, and the interpreter won't complain.

This indifference happens because arguments in ECMAScript are represented as an array internally. The array is always passed to the function, but the function doesn't care what (if anything) is in the array. If the array arrives with zero items, that's fine; if it arrives with more, that's okay, too. In fact, when a function is defined using the `function` keyword (meaning a non-arrow function), there actually is an `arguments` object that can be accessed while inside a function to retrieve the values of each argument that was passed in.

The `arguments` object acts like an array (though it isn't an instance of `Array`) in that you can access each argument using bracket notation (the first argument is `arguments[0]`, the second is `arguments[1]`, and so on) and determine how many arguments were passed in by using the `length` property.

In the following example, the `sayHi()` function's first argument is named `name`.

```
function sayHi(name, message) {
  console.log("Hello " + name + ", " + message);
}
```

The same value can be accessed by referencing `arguments[0]`. Therefore, the function can be rewritten without naming the arguments explicitly, like this:

```
function sayHi() {
  console.log("Hello " + arguments[0] + ", " + arguments[1]);
}
```

In this rewritten version, there are no named arguments. The `name` and `message` arguments have been removed, yet the function will behave appropriately. This illustrates an important point about functions in ECMAScript: named arguments are a convenience, not a necessity. Unlike in other languages, naming your arguments in ECMAScript does not create a function signature that must be matched later on; there is no validation against named arguments.

The `arguments` object can also be used to check the number of arguments passed into the function via the `length` property. The following example outputs the number of arguments passed into the function each time it is called:

```
function howManyArgs() {
  console.log(arguments.length);
}

howManyArgs("string", 45); // 2
howManyArgs();           // 0
howManyArgs(12);        // 1
```

This example shows alerts displaying 2, 0, and 1 (in that order). In this way, developers have the freedom to let functions accept any number of arguments and behave appropriately. Consider the following:

```
function doAdd() {
  if (arguments.length === 1) {
    console.log(arguments[0] + 10);
  } else if (arguments.length === 2) {
    console.log(arguments[0] + arguments[1]);
  }
}

doAdd(10);           // 20
doAdd(30, 20);      // 50
```

The function `doAdd()` adds 10 to a number only if there is one argument; if there are two arguments, they are simply added together and returned. So `doAdd(10)` returns 20, whereas `doAdd(30, 20)` returns 50. It's not quite as good as overloading, but it is a sufficient workaround for this ECMAScript limitation.

Another important thing to understand about arguments is that the `arguments` object can be used in conjunction with named arguments, such as the following:

```
function doAdd(num1, num2) {
  if (arguments.length === 1) {
    console.log(num1 + 10);
  } else if (arguments.length === 2) {
    console.log(arguments[0] + num2);
  }
}
```

In this rewrite of the `doAdd()` function, two-named arguments are used in conjunction with the `arguments` object. The named argument `num1` holds the same value as `arguments[0]`, so they can be used interchangeably (the same is true for `num2` and `arguments[1]`).

Another interesting behavior of `arguments` is that its values always stay in sync with the values of the corresponding named parameters. For example:

```
function doAdd(num1, num2) {
  arguments[1] = 10;
  console.log(arguments[0] + num2);
}
```

This version of `doAdd()` always overwrites the second argument with a value of 10. Because values in the `arguments` object are automatically reflected by the corresponding named arguments, the change to `arguments[1]` also changes the value of `num2`, so both have a value of 10. This doesn't mean that both access the same memory space, however; their memory spaces are separate but happen to be kept in sync. This effect goes only one way: changing the named argument does *not* result in a change to the corresponding value in `arguments`. Another thing to keep in mind: if only one argument is passed in, then setting `arguments[1]` to a value will not be reflected by the named argument because the length of the `arguments` object is set based on the number of arguments passed in, not the number of named arguments listed for the function.

Any named argument that is not passed into the function is automatically assigned the value `undefined`. This is akin to defining a variable without initializing it. For example, if only one argument is passed into the `doAdd()` function, then `num2` has a value of `undefined`.

Strict mode makes several changes to how the `arguments` object can be used. First, assignment, as in the previous example, no longer works. The value of `num2` remains `undefined` even though `arguments[1]` has been assigned to 10. Second, trying to overwrite the value of `arguments` is a syntax error. (The code will not execute.)

Arguments in Arrow Functions

When a function is defined using the arrow notation, the arguments passed to the function cannot be accessed using the `arguments` keyword; they can only be accessed using their named token in the function definition.

```
function foo() {
  console.log(arguments[0]);
}
foo(5); // 5

let bar = () => {
  console.log(arguments[0]);
};
bar(5); // ReferenceError: arguments is not defined
```

Although the arrow function `arguments` may not be available, be aware that it is possible that the `arguments` keyword is provided to the arrow function scope from the scope of a wrapping function being invoked:

```
function foo() {
  let bar = () => {
    console.log(arguments[0]); // 5
  };
  bar();
}

foo(5);
```

NOTE *All arguments in ECMAScript are passed by value. It is not possible to pass arguments by reference. If an object is passed as an argument, the value is just a reference to the object.*

NO OVERLOADING

ECMAScript functions cannot be overloaded in the traditional sense. In other languages, such as Java, it is possible to write two definitions of a function as long as their signatures (the type and number of arguments accepted) are different. As just discussed, functions in ECMAScript don't have signatures

because the arguments are represented as an array containing zero or more values. Without function signatures, true overloading is not possible.

If two functions are defined to have the same name in ECMAScript, it is the last function that becomes the owner of that name. Consider the following example:

```
function addSomeNumber(num) {
  return num + 100;
}

function addSomeNumber(num) {
  return num + 200;
}

let result = addSomeNumber(100); // 300
```

Here, the function `addSomeNumber()` is defined twice. The first version of the function adds 100 to the argument, and the second adds 200. When the last line is called, it returns 300 because the second function has overwritten the first.

As mentioned previously, it's possible to simulate overloading of methods by checking the type and number of arguments that have been passed into a function and then reacting accordingly.

Thinking of function names as pointers also explains why there can be no function overloading in ECMAScript. In the previous example, it's clear that declaring two functions with the same name always results in the last function overwriting the previous one. This code is almost exactly equivalent to the following:

```
let addSomeNumber = function(num) {
  return num + 100;
};

addSomeNumber = function(num) {
  return num + 200;
};

let result = addSomeNumber(100); // 300
```

In this rewritten code, it's much easier to see exactly what is going on. The variable `addSomeNumber` is simply being overwritten when the second function is created.

DEFAULT PARAMETER VALUES

In ECMAScript 5.1 and before, a common strategy for implementing default parameter values was to determine if a parameter was not provided to the function invocation by checking if it was undefined, and assigning a value to the parameter if that was the case:

```
function makeKing(name) {
  name = (typeof name !== 'undefined') ? name : 'Henry';
  return `King ${name} VIII`;
}

console.log(makeKing()); // 'King Henry VIII'
console.log(makeKing('Louis')); // 'King Louis VIII'
```

This is no longer required in ECMAScript 6, as it supports explicitly defining values for parameters if they are not provided when the function is invoked. The equivalent of the previous function with ES6 default parameters is done using the = operator directly inside the function signature:

```
function makeKing(name = 'Henry') {
  return `King ${name} VIII`;
}

console.log(makeKing('Louis')); // 'King Louis VIII'
console.log(makeKing());        // 'King Henry VIII'
```

Passing undefined as an argument is treated the same as not passing any argument, which allows for multiple independent default variables:

```
function makeKing(name = 'Henry', numerals = 'VIII') {
  return `King ${name} ${numerals}`;
}

console.log(makeKing());           // 'King Henry VIII'
console.log(makeKing('Louis'));   // 'King Louis VIII'
console.log(makeKing(undefined, 'VI')); // 'King Henry VI'
```

When using default parameters, the arguments object's value does not reflect the default value of a parameter, but rather the argument passed to the function. This mirrors the ES5 strict mode behavior and is valuable because it preserves the values as they were passed when the function was invoked:

```
function makeKing(name = 'Henry') {
  name = 'Louis';
  return `King ${arguments[0]}`;
}

console.log(makeKing());           // 'King undefined'
console.log(makeKing('Louis'));   // 'King Louis'
```

Default parameter values are not limited to primitives or object types, you can also calculate a value from an invoked function:

```
let romanNumerals = ['I', 'II', 'III', 'IV', 'V', 'VI'];
let ordinality = 0;

function getNumerals() {
  // Increment the ordinality after using it to index into the numerals array
  return romanNumerals[ordinality++];
}

function makeKing(name = 'Henry', numerals = getNumerals()) {
  return `King ${name} ${numerals}`;
}

console.log(makeKing());           // 'King Henry I'
console.log(makeKing('Louis', 'XVI')); // 'King Louis XVI'
console.log(makeKing());           // 'King Henry II'
console.log(makeKing());           // 'King Henry III'
```

The function default parameter is only invoked when the function itself is invoked, not when the function is defined. Note that the method that calculates the default value is only invoked when the argument is not provided.

Arrow functions are also capable of utilizing default parameters in the same way, although it means parentheses around a single argument is no longer optional if a default value is specified:

```
let makeKing = (name = 'Henry') => `King ${name}`;

console.log(makeKing()); // King Henry
```

Default Parameter Scope and Temporal Dead Zone

Because you can define objects and invoke functions on the fly when evaluating default parameter values, that surely means that there is some sort of execution scope for function parameters—and this is in fact the case.

Defining multiple parameters with default values operates in effectively the same way as declaring variables sequentially using the `let` keyword. Consider the following function:

```
function makeKing(name = 'Henry', numerals = 'VIII') {
  return `King ${name} ${numerals}`;
}

console.log(makeKing()); // King Henry VIII
```

The default parameter values are initialized in the order in which they are listed in the list of parameters. You can think of it as behaving similar to the following:

```
function makeKing() {
  let name = 'Henry';
  let numerals = 'VIII';

  return `King ${name} ${numerals}`;
}
```

Because the parameters are initialized in order, parameters that have their default value defined later can reference an earlier parameter. The following silly example does exactly this:

```
function makeKing(name = 'Henry', numerals = name) {
  return `King ${name} ${numerals}`;
}

console.log(makeKing()); // King Henry Henry
```

The order of parameter initialization follows the same Temporal Dead Zone rules specifying that parameter values cannot reference other parameter values that are defined later. This would throw an error:

```
// Error
function makeKing(name = numerals, numerals = 'VIII') {
  return `King ${name} ${numerals}`;
}
```

Parameters also exist inside their own scope, and therefore cannot reference the scope of the function body. This would throw an error:

```
// Error
function makeKing(name = 'Henry', numerals = defaultNumeral) {
  let defaultNumeral = 'VIII';
  return `King ${name} ${numerals}`;
}
```

SPREAD ARGUMENTS AND REST PARAMETERS

ECMAScript 6 introduces the spread operator, which allows for a very elegant way of managing and grouping collections. One of its most useful applications is in the domain of function signatures where it shines especially brightly in the domain of weak typing and variable length arguments. The spread operator is useful both when invoking a function, as well as when defining a function's parameters.

Spread Arguments

Instead of passing an array as a single function argument, it is often useful to be able to break apart an array of values and individually pass each value as a separate argument.

Suppose you have the following function defined, which sums all the values passed as arguments:

```
let values = [1, 2, 3, 4];

function getSum() {
  let sum = 0;
  for (let i = 0; i < arguments.length; ++i) {
    sum += arguments[i];
  }
  return sum;
}
```

This function expects each of its arguments to be an individual number that will be iterated through to find the sum. An array outside the function containing all the values you want to sum is a logical format, but the most prudent way to flatten this array into separate parameters is to inelegantly utilize `.apply()`:

```
console.log(getSum.apply(null, values)); // 10
```

In ECMAScript 6, you are now able to perform this action more succinctly using the spread operator. Applying the spread operator to an iterable object and passing that as a single argument to a function will break apart that iterable object of size *N* and pass it to the function as *N* separate arguments.

With the spread operator, you can unpack the outer array into individual arguments directly inside the function invocation:

```
console.log(getSum(...values)); // 10
```

Because the size of the array is known, there are no restrictions on other parameters appearing before or after the spread operator, including other spread operators:

```
console.log(getSum(-1, ...values)); // 9
console.log(getSum(...values, 5)); // 15
console.log(getSum(-1, ...values, 5)); // 14
console.log(getSum(...values, ...[5,6,7])); // 28
```

The presence of the spread operator is totally unknown to the `arguments` object; it will treat the value being broken apart as separate pieces because that is how they are passed to the function:

```
let values = [1,2,3,4]

function countArguments() {
```

```

    console.log(arguments.length);
  }

  countArguments(-1, ...values);           // 5
  countArguments(...values, 5);           // 5
  countArguments(-1, ...values, 5);       // 6
  countArguments(...values, ...[5,6,7]); // 7

```

The `arguments` object is only one way to consume spread arguments. Spread arguments can be used as named parameters in both standard functions and arrow functions, as well as alongside default arguments:

```

function getProduct(a, b, c = 1) {
  return a * b * c;
}

let getSum = (a, b, c = 0) => {
  return a + b + c;
}

console.log(getProduct(...[1,2]));       // 2
console.log(getProduct(...[1,2,3]));     // 6
console.log(getProduct(...[1,2,3,4]));   // 6

console.log(getSum(...[0,1]));           // 1
console.log(getSum(...[0,1,2]));         // 3
console.log(getSum(...[0,1,2,3]));       // 3

```

Rest Parameter

When composing a function definition, instead of handling parameters individually, it is possible to use the spread operator to combine ranges of parameters of variable length into a single array. In many ways, this is very similar to how the `arguments` object works, but in this case the rest parameter becomes a formal `Array` object.

```

function getSum(...values) {
  // Sequentially sum all elements in 'values'
  // Initial total = 0
  return values.reduce((x, y) => x + y, 0);
}

console.log(getSum(1,2,3)); // 6

```

If there are named parameters preceding the rest parameter, it will assume the size of the remaining parameters that remain unnamed, or an empty array if there are none. Because the rest parameter is variable in size, you are only able to use it as the last formal parameter:

```

// Error
function getProduct(...values, lastValue) {}

// OK
function ignoreFirst(firstValue, ...values) {
  console.log(values);
}

```

```

ignoreFirst(); // []
ignoreFirst(1); // []
ignoreFirst(1,2); // [2]
ignoreFirst(1,2,3); // [2, 3]

```

Although arrow functions do not support the `arguments` object, they do support rest parameters, which affords you behavior that is extremely similar to `arguments`:

```

let getSum = (...values) => {
  return values.reduce((x, y) => x + y, 0);
}

console.log(getSum(1,2,3)); // 6

```

As you might expect, using a rest parameter does not affect the `arguments` object—it will still exactly reflect what was passed to the function:

```

function getSum(...values) {
  console.log(arguments.length); // 3
  console.log(arguments); // [1, 2, 3]
  console.log(values); // [1, 2, 3]
}

console.log(getSum(1,2,3));

```

FUNCTION DECLARATIONS VERSUS FUNCTION EXPRESSIONS

Throughout this section, the function declaration and function expression are referred to as being almost equivalent. This hedging is due to one major difference in the way that a JavaScript engine loads data into the execution context. Function declarations are read and available in an execution context before any code is executed, whereas function expressions aren't complete until the execution reaches that line of code. Consider the following:

```

// OK
console.log(sum(10, 10));
function sum(num1, num2) {
  return num1 + num2;
}

```

This code runs perfectly because function declarations are read and added to the execution context before the code begins running through a process called *function declaration hoisting*. As the code is being evaluated, the JavaScript engine does a first pass for function declarations and pulls them to the top of the source tree. So even though the function declaration appears after its usage in the code, the engine changes this to *hoist* the function declarations to the top. Changing the function declaration to an equivalent function expression, as in the following example, will cause an error during execution:

```

// Error
console.log(sum(10, 10));
let sum = function(num1, num2) {
  return num1 + num2;
};

```

This updated code will cause an error because the function is part of an initialization statement, not part of a function declaration. That means the function isn't available in the variable `sum` until the

highlighted line has been executed, which won't happen, because the first line causes an “unexpected identifier” error. This is not a consequence of using `let`, as using the `var` keyword will result in the same problem:

```
console.log(sum(10, 10));
var sum = function(num1, num2) {
  return num1 + num2;
};
```

Aside from this difference in when the function is available by the given name, the two syntaxes are equivalent.

NOTE *It is possible to have named function expressions that look like declarations, such as `let sum = function sum() {}`. This is discussed in the Function Expressions section of this chapter.*

FUNCTIONS AS VALUES

Because function names in ECMAScript are nothing more than variables, functions can be used anywhere variables can be used. This means it's possible not only to pass a function into another function as an argument, but also to return a function as the result of another function. Consider the following function:

```
function callSomeFunction(someFunction, someArgument) {
  return someFunction(someArgument);
}
```

This function accepts two arguments. The first argument should be a function, and the second argument should be a value to pass to that function. Any function can then be passed in as follows:

```
function add10(num) {
  return num + 10;
}

let result1 = callSomeFunction(add10, 10);
console.log(result1); // 20

function getGreeting(name) {
  return "Hello, " + name;
}

let result2 = callSomeFunction(getGreeting, "Nicholas");
console.log(result2); // "Hello, Nicholas"
```

The `callSomeFunction()` function is generic, so it doesn't matter what function is passed in as the first argument—the result will always be returned from the first argument being executed. Remember that to access a function pointer instead of executing the function, you must leave off the parentheses,

so the variables `add10` and `getGreeting` are passed into `callSomeFunction()` instead of their results being passed in.

Returning a function from a function is also possible and can be quite useful. For instance, suppose that you have an array of objects and want to sort the array on an arbitrary object property. A comparison function for the array's `sort()` method accepts only two arguments, which are the values to compare, but really you need a way to indicate which property to sort by. This problem can be addressed by defining a function to create a comparison function based on a property name, as in the following example:

```
function createComparisonFunction(propertyName) {
  return function(object1, object2) {
    let value1 = object1[propertyName];
    let value2 = object2[propertyName];

    if (value1 < value2) {
      return -1;
    } else if (value1 > value2) {
      return 1;
    } else {
      return 0;
    }
  };
}
```

This function's syntax may look complicated, but it's just a function inside of a function, preceded by the `return` operator. The `propertyName` argument is accessible from the inner function and is used with bracket notation to retrieve the value of the given property. Once the property values are retrieved, a simple comparison can be done. This function can be used as in the following example:

```
let data = [
  {name: "Zachary", age: 28},
  {name: "Nicholas", age: 29}
];

data.sort(createComparisonFunction("name"));
console.log(data[0].name); // Nicholas

data.sort(createComparisonFunction("age"));
console.log(data[0].name); // Zachary
```

In this code, an array called `data` is created with two objects. Each object has a `name` property and an `age` property. By default, the `sort()` method would call `toString()` on each object to determine the sort order, which wouldn't give logical results in this case. Calling `createComparisonFunction("name")` creates a comparison function that sorts based on the `name` property, which means the first item will have the name "Nicholas" and an age of 29. When `createComparisonFunction("age")` is called, it creates a comparison function that sorts based on the `age` property, meaning the first item will be the one with its name equal to "Zachary" and age equal to 28.

FUNCTION INTERNALS

In ECMAScript 5, two special objects exist inside a function: `arguments` and `this`. In ECMAScript 6, the `new.target` property was introduced.

arguments

The `arguments` object, as discussed previously, is an array-like object that contains all of the arguments that were passed into the function. It is only available when a function is declared using the `function` keyword (as opposed to arrow function declaration). Though its primary use is to represent function arguments, the `arguments` object also has a property named `callee`, which is a pointer to the function that owns the `arguments` object. Consider the following classic factorial function:

```
function factorial(num) {
  if (num <= 1) {
    return 1;
  } else {
    return num * factorial(num - 1);
  }
}
```

Factorial functions are typically defined to be recursive, as in this example, which works fine when the name of the function is set and won't be changed. However, the proper execution of this function is tightly coupled with the function name "factorial". It can be decoupled by using `arguments.callee` as follows:

```
function factorial(num) {
  if (num <= 1) {
    return 1;
  } else {
    return num * arguments.callee(num - 1);
  }
}
```

In this rewritten version of the `factorial()` function, there is no longer a reference to the name "factorial" in the function body, which ensures that the recursive call will happen on the correct function no matter how the function is referenced. Consider the following:

```
let trueFactorial = factorial;

factorial = function() {
  return 0;
};

console.log(trueFactorial(5)); // 120
console.log(factorial(5));    // 0
```

Here, the variable `trueFactorial` is assigned the value of `factorial`, effectively storing the function pointer in a second location. The `factorial` variable is then reassigned to a function that simply returns 0. Without using `arguments.callee` in the original `factorial()` function's body, the call to `trueFactorial()` would return 0. However, with the function decoupled from the function name, `trueFactorial()` correctly calculates the factorial, and `factorial()` is the only function that returns 0.

this

The next special object is called `this`, which behaves differently when used inside a standard function and an arrow function.

Inside a standard function, it is a reference to the context object that the function is operating on—often called the *this value* (when a function is called in the global scope of a web page, the `this` object points to `window`). Consider the following:

```

window.color = 'red';
let o = {
  color: 'blue'
};

function sayColor() {
  console.log(this.color);
}

sayColor();    // 'red'

o.sayColor = sayColor;
o.sayColor(); // 'blue'

```

The function `sayColor()` is defined globally but references the `this` object. The value of `this` is not determined until the function is called, so its value may not be consistent throughout the code execution. When `sayColor()` is called in the global scope, it outputs "red" because `this` is pointing to `window`, which means `this.color` evaluates to `window.color`. By assigning the function to the object `o` and then calling `o.sayColor()`, the `this` object points to `o`, so `this.color` evaluates to `o.color` and "blue" is displayed.

Inside an arrow function, `this` references the context in which the arrow function expression is defined. This is demonstrated in the following example, where two different invocations of `sayColor` both reference the property of the `window` object, which is the context inside which the arrow function was initially defined:

```

window.color = 'red';
let o = {
  color: 'blue'
};

let sayColor = () => console.log(this.color);

sayColor();    // 'red'

o.sayColor = sayColor;
o.sayColor(); // 'red'

```

This is especially useful in situations where events or timeouts will invoke a function inside a callback where the invoking object is not the intended object. When an arrow function is used in these situations, the context referenced by `this` is preserved:

```

function King() {
  this.royaltyName = 'Henry';
}

```

```

    // 'this' will be the King instance
    setTimeout(() => console.log(this.royaltyName), 1000);
  }

  function Queen() {
    this.royaltyName = 'Elizabeth';

    // 'this' will be the window object
    setTimeout(function() { console.log(this.royaltyName); }, 1000);
  }

  new King(); // Henry
  new Queen(); // undefined

```

NOTE Remember that function names are simply variables containing pointers, so the global `sayColor()` function and `o.sayColor()` point to the same function even though they execute in different contexts.

caller

ECMAScript 5 also formalizes an additional property on a function object: `caller`. Though not defined in ECMAScript 3, all browsers except earlier versions of Opera supported this property, which contains a reference to the function that called this function or `null` if the function was called from the global scope. For example:

```

function outer() {
  inner();
}
function inner() {
  console.log(inner.caller);
}
outer();

```

This code displays an alert with the source text of the `outer()` function. Because `outer()` calls `inner()`, `inner.caller` points back to `outer()`. For looser coupling, you can also access the same information via `arguments.callee.caller`:

```

function outer() {
  inner();
}

function inner() {
  console.log(arguments.callee.caller);
}

outer();

```

When function code executes in strict mode, attempting to access `arguments.callee` results in an error. ECMAScript 5 also defines `arguments.caller`, which also results in an error in strict mode and is always undefined outside of strict mode. This is to clear up confusion between

`arguments.caller` and the `caller` property of functions. These changes were made as security additions to the language, so third-party code could not inspect other code running in the same context.

Strict mode places one additional restriction: you cannot assign a value to the `caller` property of a function. Doing so results in an error.

new.target

Functions have always been able to behave as both a constructor to instantiate a new object, and as a normal callable function. New in ECMAScript 6 is the ability to determine if a function was invoked with the `new` keyword using `new.target`. If a function is called normally, `new.target` will be undefined. If a function is called using the `new` keyword, `new.target` will reference the constructor or function.

```
function King() {
  if (!new.target) {
    throw 'King must be instantiated using "new"'
  }
  console.log('King instantiated using "new"');
}

new King(); // King instantiated using "new"
King();    // Error: King must be instantiated using "new"
```

FUNCTION PROPERTIES AND METHODS

Functions are objects in ECMAScript and, as mentioned previously, therefore have properties and methods. Each function has two properties: `length` and `prototype`. The `length` property indicates the number of named arguments that the function expects, as in this example:

```
function sayName(name) {
  console.log(name);
}

function sum(num1, num2) {
  return num1 + num2;
}

function sayHi() {
  console.log("hi");
}

console.log(sayName.length); // 1
console.log(sum.length);    // 2
console.log(sayHi.length);  // 0
```

This code defines three functions, each with a different number of named arguments. The `sayName()` function specifies one argument, so its `length` property is set to 1. Similarly, the `sum()` function specifies two arguments, so its `length` property is 2, and `sayHi()` has no named arguments, so its `length` is 0.

The `prototype` property is perhaps the most interesting part of the ECMAScript core. The `prototype` is the actual location of all instance methods for reference types, meaning methods

such as `toString()` and `valueOf()` actually exist on the `prototype` and are then accessed from the object instances. This property is very important in terms of defining your own reference types and inheritance. (These topics are covered in the chapter “Objects, Classes, and Object-Oriented Programming.”) In ECMAScript 5, the `prototype` property is not enumerable and so will not be found using `for-in`.

There are two additional methods for functions: `apply()` and `call()`. These methods both call the function with a specific `this` value, effectively setting the value of the `this` object inside the function body. The `apply()` method accepts two arguments: the value of `this` inside the function and an array of arguments. This second argument may be an instance of `Array`, but it can also be the `arguments` object. Consider the following:

```
function sum(num1, num2) {
    return num1 + num2;
}

function callSum1(num1, num2) {
    return sum.apply(this, arguments); // passing in arguments object
}

function callSum2(num1, num2) {
    return sum.apply(this, [num1, num2]); // passing in array
}

console.log(callSum1(10, 10)); // 20
console.log(callSum2(10, 10)); // 20
```

In this example, `callSum1()` executes the `sum()` method, passing in `this` as the `this` value (which is equal to `window` because it’s being called in the global scope) and also passing in the `arguments` object. The `callSum2()` method also calls `sum()`, but it passes in an array of the arguments instead. Both functions will execute and return the correct result.

NOTE *In strict mode, the `this` value of a function called without a context object is not coerced to `window`. Instead, this becomes `undefined` unless explicitly set by either attaching the function to an object or using `apply()` or `call()`.*

The `call()` method exhibits the same behavior as `apply()`, but arguments are passed to it differently. The first argument is the `this` value, but the remaining arguments are passed directly into the function. Using `call()` arguments must be enumerated specifically, as in this example:

```
function sum(num1, num2) {
    return num1 + num2;
}

function callSum(num1, num2) {
    return sum.call(this, num1, num2);
}

console.log(callSum(10, 10)); // 20
```

The `callSum()` method must pass in each of its arguments explicitly into the `call()` method. The result is the same as using `apply()`. The decision to use either `apply()` or `call()` depends solely on the easiest way for you to pass arguments into the function. If you intend to pass in the `arguments` object directly or if you already have an array of data to pass in, then `apply()` is the better choice; otherwise, `call()` may be a more appropriate choice. (If there are no arguments to pass in, these methods are identical.)

The true power of `apply()` and `call()` lies not in their ability to pass arguments but rather in their ability to augment the `this` value inside of the function. Consider the following example:

```

window.color = 'red';
let o = {
  color: 'blue'
};

function sayColor() {
  console.log(this.color);
}

sayColor();           // red

sayColor.call(this); // red
sayColor.call(window); // red
sayColor.call(o);    // blue

```

This example is a modified version of the one used to illustrate the `this` object. Once again, `sayColor()` is defined as a global function, and when it's called in the global scope, it displays "red" because `this.color` evaluates to `window.color`. You can then call the function explicitly in the global scope by using `sayColor.call(this)` and `sayColor.call(window)`, which both display "red". Running `sayColor.call(o)` switches the context of the function such that `this` points to `o`, resulting in a display of "blue".

The advantage of using `call()` (or `apply()`) to augment the scope is that the object doesn't need to know anything about the method. In the first version of this example, the `sayColor()` function was placed directly on the object `o` before it was called; in the updated example, that step is no longer necessary.

ECMAScript 5 defines an additional method called `bind()`. The `bind()` method creates a new function instance whose `this` value is *bound* to the value that was passed into `bind()`. For example:

```

window.color = 'red';
var o = {
  color: 'blue'
};

function sayColor() {
  console.log(this.color);
}
let objectSayColor = sayColor.bind(o);
objectSayColor(); // blue

```

Here, a new function called `objectSayColor()` is created from `sayColor()` by calling `bind()` and passing in the object `o`. The `objectSayColor()` function has a `this` value equivalent to `o`, so calling the function, even as a global call, results in the string "blue" being displayed.

For functions, the inherited methods `toLocaleString()` and `toString()` always return the function's code. The exact format of this code varies from browser to browser—some return your code exactly as it appeared in the source code, including comments, whereas others return the internal representation of your code, which has comments removed and possibly some code changes that the interpreter made. Because of these differences, you can't rely on what is returned for any important functionality, though this information may be useful for debugging purposes. The inherited method `valueOf()` simply returns the function itself.

FUNCTION EXPRESSIONS

One of the more powerful, and often confusing, parts of JavaScript is function expressions. There are two ways to define a function: by function declaration and by function expression. The first, function declaration, has the following form:

```
function functionName(arg0, arg1, arg2) {
  // function body
}
```

One of the key characteristics of function declarations is *function declaration hoisting*, whereby function declarations are read before the code executes. That means a function declaration may appear after code that calls it and still work:

```
sayHi();
function sayHi() {
  console.log("Hi!");
}
```

This example doesn't throw an error because the function declaration is read first before the code begins to execute.

The second way to create a function is by using a function expression. Function expressions have several forms. The most common is as follows:

```
let functionName = function(arg0, arg1, arg2) {
  // function body
};
```

This pattern of function expression looks like a normal variable assignment. A function is created and assigned to the variable `functionName`. The created function is considered to be an *anonymous function*, because it has no identifier after the `function` keyword. (Anonymous functions are also sometimes called *lambda functions*.) This means the `name` property is the empty string.

Function expressions act like other expressions and, therefore, must be assigned before usage. The following causes an error:

```
sayHi(); // Error! function doesn't exist yet
let sayHi = function() {
  console.log("Hi!");
};
```

Understanding function hoisting is key to understanding the differences between function declarations and function expressions. For instance, the result of the following code may be surprising:

```
// Never do this!
if (condition) {
  function sayHi() {
    console.log('Hi!');
  }
} else {
  function sayHi() {
    console.log('Yo!');
  }
}
```

The code seems to indicate that if `condition` is `true`, use one definition for `sayHi()`; otherwise, use a different definition. In fact, this is not valid syntax in ECMAScript, so JavaScript engines try to error correct into an appropriate state. The problem is that browsers don't consistently error correct in this case. Most browsers return the second declaration regardless of `condition`; Firefox returns the first when `condition` is `true`. This pattern is dangerous and should not be used. It is perfectly fine, however, to use function expressions in this way:

```
// OK
let sayHi;
if (condition) {
  sayHi = function() {
    console.log("Hi!");
  };
} else {
  sayHi = function() {
    console.log("Yo!");
  };
}
```

This example behaves the way you would expect, assigning the correct function expression to the variable `sayHi` based on `condition`.

The ability to create functions for assignment to variables also allows you to return functions as the value of other functions.

```
function createComparisonFunction(propertyName) {
  return function(object1, object2) {
    let value1 = object1[propertyName];
    let value2 = object2[propertyName];

    if (value1 < value2) {
      return -1;
    } else if (value1 > value2) {
      return 1;
    } else {
      return 0;
    }
  };
}
```

`createComparisonFunction()` returns an anonymous function. The returned function will, presumably, be either assigned to a variable or otherwise called, but within `createComparisonFunction()` it is anonymous. Any time a function is being used as a value, it is a function expression. However, these are not the only uses for function expressions, as the rest of this chapter will show.

RECURSION

A *recursive function* typically is formed when a function calls itself by name, as in the following example:

```
function factorial(num) {
  if (num <= 1) {
    return 1;
  } else {
    return num * factorial(num - 1);
  }
}
```

This is the classic recursive factorial function. Although this works initially, it's possible to prevent it from functioning by running the following code immediately after it:

```
let anotherFactorial = factorial;
factorial = null;
console.log(anotherFactorial(4)); // error!
```

Here, the `factorial()` function is stored in a variable called `anotherFactorial`. The `factorial` variable is then set to `null`, so only one reference to the original function remains. When `anotherFactorial()` is called, it will cause an error because it will try to execute `factorial()`, which is no longer a function. Using `arguments.callee` can alleviate this problem.

Recall that `arguments.callee` is a pointer to the function being executed and, as such, can be used to call the function recursively, as shown here:

```
function factorial(num) {
  if (num <= 1) {
    return 1;
  } else {
    return num * arguments.callee(num - 1);
  }
}
```

Changing the highlighted line to use `arguments.callee` instead of the function name ensures that this function will work regardless of how it is accessed. It's advisable to always use `arguments.callee` of the function name whenever you're writing recursive functions.

The value of `arguments.callee` is not accessible to a script running in strict mode and will cause an error when attempts are made to read it. Instead, you can use *named function expressions* to achieve the same result. For example:

```
const factorial = (function f(num) {
  if (num <= 1) {
    return 1;
  } else {
```



```
    return num * f(num - 1);
  }
});
```

In this code, a named function expression `f()` is created and assigned to the variable `factorial`. The name `f` remains the same even if the function is assigned to another variable, so the recursive call will always execute correctly. This pattern works in both nonstrict mode and strict mode.

TAIL CALL OPTIMIZATION

The ECMAScript 6 specification also introduced a memory management optimization that allows the JavaScript engine to reuse stack frames when certain conditions are met. Specifically, this optimization pertains to “tail calls”, where the return value of an outer function is the returned value of an inner function, as follows:

```
function outerFunction() {
  return innerFunction(); // tail call
}
```

Prior to the ES6 optimization, executing this example would have the following effect in memory:

1. Execution reaches `outerFunction` body, first stack frame is pushed onto stack.
2. Body of `outerFunction` executes, return statement is reached. To evaluate the return statement, `innerFunction` must be evaluated.
3. Execution reaches `innerFunction` body, second stack frame is pushed onto stack.
4. Body of `innerFunction` executes, and its returned value is evaluated.
5. Return value is passed back to `outerFunction`, which in turn can return that value.
6. Stack frames are popped off the stack.

With the ES6 optimization, executing this example would have the following effect in memory:

1. Execution reaches `outerFunction` body, first stack frame is pushed onto stack.
2. Body of `outerFunction` executes, return statement is reached. To evaluate the return statement, `innerFunction` must be evaluated.
3. Engine recognizes that first stack frame can safely be popped off the stack since the return value of `innerFunction` is also the return value of `outerFunction`.
4. `outerFunction` stack frame is popped off the stack.
5. Execution reaches `innerFunction` body, stack frame is pushed onto stack.
6. Body of `innerFunction` executes, and its returned value is evaluated.
7. `innerFunction` stack frame is popped off the stack.

The obvious difference here is that the first implementation will incur an additional stack frame for every successive nested function call, whereas the second implementation will incur a single stack frame for the entire length of execution. This is the core of the ES6 tail call optimization:

if the function is structured in a way that allows it to be safely discarded upon the tail call, the engine will do so.

NOTE *There is no ability to directly measure if the tail call optimization is occurring. However, since this is part of the ES6 specification, browsers that are compliant are guaranteed to apply the optimization if your code satisfies the requirements.*

Tail Call Optimization Requirements

The engine is only capable of performing such an optimization when it is sure that the outer stack frame is truly not needed any longer. This demands the following conditions:

- The code is executing in strict mode
- The return value of the outer function is the invoked tail call function
- There is no further execution required after the tail call function returns
- The tail call function is not a closure that refers to variables in the outer function's scope

The following are a few examples that violate these conditions and therefore are not subject to the tail call optimization:

```
"use strict";

// No optimization: tail call is not returned
function outerFunction() {
  innerFunction();
}

// No optimization: tail call is not directly returned
function outerFunction() {
  let innerFunctionResult = innerFunction();
  return innerFunctionResult;
}

// No optimization: tail call must be cast as a string after return
function outerFunction() {
  return innerFunction().toString();
}

// No optimization: tail call is a closure
function outerFunction() {
  let foo = 'bar';
  function innerFunction() { return foo; }

  return innerFunction();
}
```

The following are a few examples which do not violate these conditions, and therefore will be optimized:

```
"use strict";

// Optimization used: argument computation occurs before stack frame is discarded
function outerFunction(a, b) {
  return innerFunction(a + b);
}

// Optimization used: initial return values do not have stack frame implications
function outerFunction(a, b) {
  if (a < b) {
    return a;
  }
  return innerFunction(a + b);
}

// Optimization used: both inner functions are considered to be in a tail position
function outerFunction(condition) {
  return condition ? innerFunctionA() : innerFunctionB();
}
```

A common source of confusion is the nature of differentiating tail calls and recursive calls. The optimization will be applied to recursive or non-recursive tail calls; the engine makes no distinction if the function is calling itself or a different function in the tail call. However, your code will stand to see the most benefit from this optimization in recursive situations, as this code is the form factor which tends to swamp the stack with stack frames.

NOTE *The reason for requiring strict mode is that non-strict mode function invocation allows the use of `f.arguments` and `f.caller`, which are references to the outer function's stack frame. Obviously, this means the optimization would not be possible, and therefore the strict mode requirement exists to prevent these properties from existing.*

Coding for Tail Call Optimization

It's instructive to convert a naïve recursive function into one which will be optimized. Take the following simple Fibonacci example:

```
function fib(n) {
  if (n < 2) {
    return n;
  }

  return fib(n - 1) + fib(n - 2);
}
```

```

console.log(fib(0)); // 0
console.log(fib(1)); // 1
console.log(fib(2)); // 1
console.log(fib(3)); // 2
console.log(fib(4)); // 3
console.log(fib(5)); // 5
console.log(fib(6)); // 8

```

It's easy to see that this function is not subject to tail call optimization since there is a disqualifying add operation occurring in the return statement. As a result, the number of stack frames for `fib(n)` will have a memory complexity of $O(2^n)$. Therefore, it's very simple to swamp your browser with something as simple as:

```
fib(1000);
```

Of course, there are techniques which solve this problem differently such as memoization or flattening into an iterative loop, but you can keep this implementation recursive and refactor it into an optimization-compatible form. An excellent strategy is to nest two functions: the outer one acting as the base case, and the inner one acting as the recursive case:

```

"use strict";

// base case
function fib(n) {
  return fibImpl(0, 1, n);
}

// recursive case
function fibImpl(a, b, n) {
  if (n === 0) {
    return a;
  }
  return fibImpl(b, a + b, n - 1);
}

```

With this implementation, all tail call optimization requirements are satisfied, and your browser will have no problems with `fib(1000)`;

CLOSURES

The terms *anonymous functions* and *closures* are often incorrectly used interchangeably. *Closures* are functions that have access to variables from another function's scope. This is often accomplished by creating a function inside a function, as in the following highlighted lines from the previous `createComparisonFunction()` example:

```

function createComparisonFunction(propertyName) {
  return function(object1, object2) {
    let value1 = object1[propertyName];
    let value2 = object2[propertyName];

    if (value1 < value2) {
      return -1;
    }
  };
}

```

```

    } else if (value1 > value2) {
      return 1;
    } else {
      return 0;
    }
  };
}

```

The highlighted lines in this example are part of the inner function (an anonymous function) that is accessing a variable (`propertyName`) from the outer function. Even after the inner function has been returned and is being used elsewhere, it has access to that variable. This occurs because the inner function’s scope chain includes the scope of `createComparisonFunction()`. To understand why this is possible, consider what happens when a function is first called.

The chapter “Variables, Scope, and Memory” introduced the concept of a scope chain. The details of how scope chains are created and used are important for a good understanding of closures. When a function is called, an execution context is created, and its scope chain is created. The activation object for the function is initialized with values for `arguments` and any named arguments. The outer function’s activation object is the second object in the scope chain. This process continues for all containing functions until the scope chain terminates with the global execution context.

As the function executes, variables are looked up in the scope chain for the reading and writing of values. Consider the following:

```

function compare(value1, value2) {
  if (value1 < value2) {
    return -1;
  } else if (value1 > value2) {
    return 1;
  } else {
    return 0;
  }
}

let result = compare(5, 10);

```

This code defines a function named `compare()` that is called in the global execution context. When `compare()` is called for the first time, a new activation object is created that contains `arguments`, `value1`, and `value2`. The global execution context’s variable object is next in the `compare()` execution context’s scope chain, which contains `this`, `result`, and `compare`. Figure 10-1 illustrates this relationship.

Behind the scenes, an object represents the variables in each execution context. The global context’s variable object always exists, whereas local context variable objects, such as the one for `compare()`, exist only while the function is being executed. When `compare()` is defined, its scope chain is created, preloaded with the global variable object, and saved to the internal `[[Scope]]` property. When the function is called, an execution context is created and its scope chain is built up by copying the objects in the function’s `[[Scope]]` property. After that, an activation object (which also acts as a variable object) is created and pushed to the front of the context’s scope chain. In this example, that means the `compare()` function’s execution context has two variable objects in its scope chain: the local activation object and the global variable object. Note that the scope chain is essentially a list of pointers to variable objects and does not physically contain the objects.

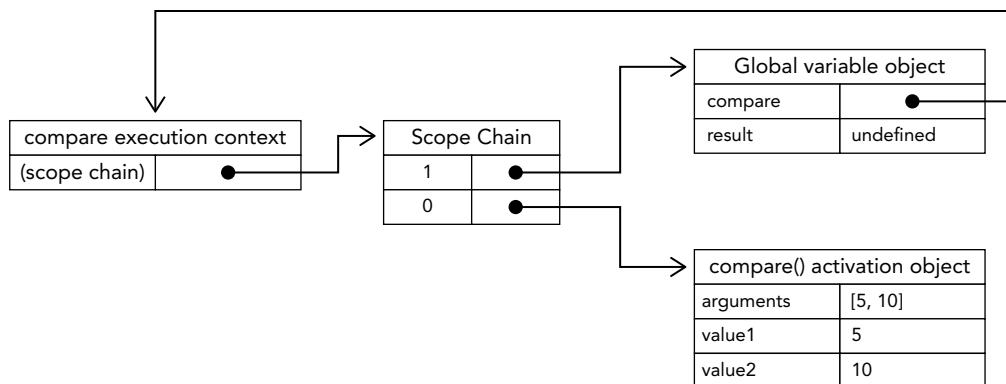

FIGURE 10-1

Whenever a variable is accessed inside a function, the scope chain is searched for a variable with the given name. Once the function has completed, the local activation object is destroyed, leaving only the global scope in memory. Closures, however, behave differently.

A function that is defined inside another function adds the containing function's activation object into its scope chain. So, in `createComparisonFunction()`, the anonymous function's scope chain actually contains a reference to the activation object for `createComparisonFunction()`. Figure 10-2 illustrates this relationship when the following code is executed:

```
let compare = createComparisonFunction('name');
let result = compare({ name: 'Nicholas' }, { name: 'Matt' });
```

When the anonymous function is returned from `createComparisonFunction()`, its scope chain has been initialized to contain the activation object from `createComparisonFunction()` and the global variable object. This gives the anonymous function access to all of the variables from `createComparisonFunction()`. Another interesting side effect is that the activation object from `createComparisonFunction()` cannot be destroyed once the function finishes executing, because a reference still exists in the anonymous function's scope chain. After `createComparisonFunction()` completes, the scope chain for its execution context is destroyed, but its activation object will remain in memory until the anonymous function is destroyed, as in the following:

```
// create function
let compareNames = createComparisonFunction('name');

// call function
let result = compareNames({ name: 'Nicholas' }, { name: 'Matt' });

// dereference function - memory can now be reclaimed
compareNames = null;
```

Here, the comparison function is created and stored in the variable `compareNames`. Setting `compareNames` equal to `null` dereferences the function and allows the garbage collection routine to clean it up. The scope chain will then be destroyed, and all of the scopes (except the global scope) can be destroyed safely. Figure 10-2 shows the scope-chain relationships that occur when `compareNames()` is called in this example.

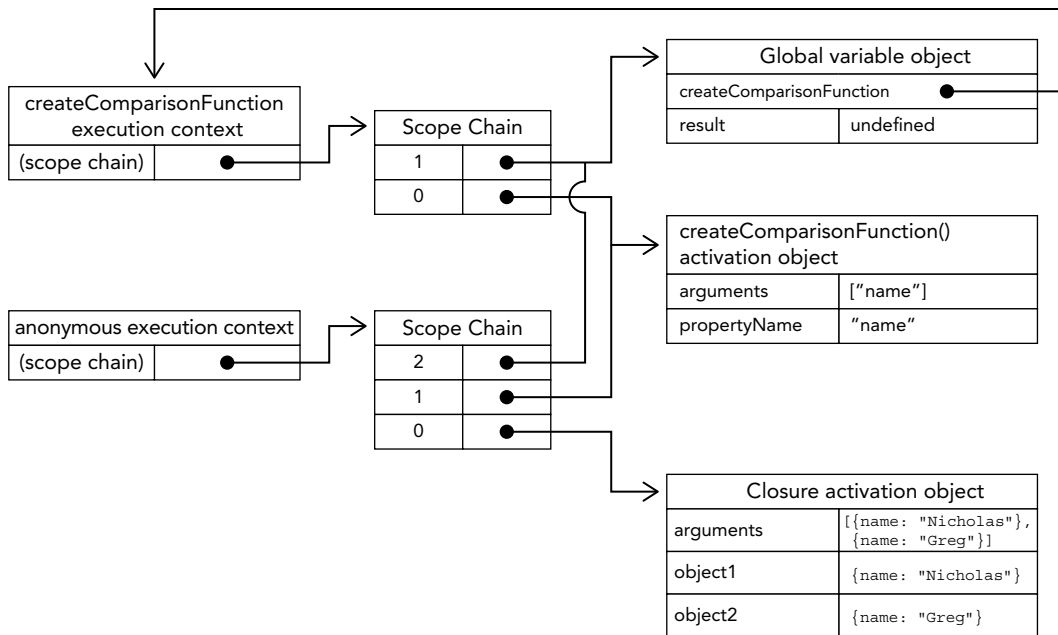

FIGURE 10-2

NOTE Because closures carry with them the containing function's scope, they take up more memory than other functions. Overuse of closures can lead to excess memory consumption, so it's recommended you use them only when absolutely necessary. Optimizing JavaScript engines, such as V8, make attempts to reclaim memory that is trapped because of closures, but it's still recommended to be careful when using closures.

The this Object

Using the `this` object inside closures introduces some complex behaviors. When a function is not defined using the arrow syntax, the `this` object is bound at runtime based on the context in which a function is executed: when used inside global functions, `this` is equal to `window` in nonstrict mode and `undefined` in strict mode, whereas `this` is equal to the object when called as an object method. Anonymous functions are not bound to an object in this context, meaning the `this` object points to `window` unless executing in strict mode (where `this` is `undefined`). Because of the way closures are written, however, this fact is not always obvious. Consider the following:

```
window.identity = 'The Window';

let object = {
```

```

    identity: 'My Object',
    getIdentityFunc() {
      return function() {
        return this.identity;
      };
    }
  };

  console.log(object.getIdentityFunc()()); // 'The Window'

```

Here, a global variable called `name` is created along with an object that also contains a property called `name`. The object contains a method, `getNameFunc()`, that returns an anonymous function, which returns `this.identity`. Because `getIdentityFunc()` returns a function, calling `object.getIdentityFunc()()` immediately calls the function that is returned, which returns a string. In this case, however, it returns `'The Window'`, which is the value of the global `identity` variable. Why didn't the anonymous function pick up the containing scope's `this` object?

Remember that each function automatically gets two special variables as soon as the function is called: `this` and `arguments`. An inner function can never access these variables directly from an outer function. It is possible to allow a closure access to a different `this` object by storing it in another variable that the closure can access, as in this example:

```

window.identity = 'The Window';

let object = {
  identity: 'My Object',
  getIdentityFunc() {
    let that = this;
    return function() {
      return that.identity;
    };
  }
};

console.log(object.getIdentityFunc()()); // 'My Object'

```

The two highlighted lines show the difference between this example and the previous one. Before defining the anonymous function, a variable named `that` is assigned equal to the `this` object. When the closure is defined, it has access to `that` because it is a uniquely named variable in the containing function. Even after the function is returned, `that` is still bound to `object`, so calling `object.getIdentityFunc()()` returns `'My Object'`.

NOTE *Both `this` and `arguments` behave in this way. If you want access to a containing scope's arguments object, you'll need to save a reference into another variable that the closure can access.*

There are a few special cases where the value of `this` may not end up as the value you expect. Consider the following modification to the previous example:

```

window.identity = 'The Window';
let object = {

```



```

    identity: 'My Object',
    getIdentity () {
        return this.identity;
    }
};

```

The `getIdentity()` method simply returns the value of `this.identity`. Here are various ways to call `object.getIdentity()` and the results:

```

object.getIdentity(); // 'My Object'
(object.getIdentity)(); // 'My Object'
(object.getIdentity = object.getIdentity)(); // 'The Window'

```

The first line calls `object.getIdentity()` in the way you normally would and so returns `'My Object'`, as `this.identity` is the same as `object.identity`. The second line places parentheses around `object.getIdentity` before calling it. While this might seem to be a reference just to the function, the `this` value is maintained because `object.getIdentity` and `(object.getIdentity)` are defined to be equivalent. The third line performs an assignment and then calls the result. Because the value of this assignment expression is the function itself, the `this` value is not maintained, and so `'The Window'` is returned.

It's unlikely that you'll intentionally use the patterns in lines two or three, but it is helpful to know that the value of `this` can change in unexpected ways when syntax is changed slightly.

Memory Leaks

The way closures work causes particular problems in Internet Explorer prior to version 9 because of the different garbage-collection routines used for JScript objects versus COM objects (discussed in Chapter 4). Storing a scope in which an HTML element is stored effectively ensures that the element cannot be destroyed. Consider the following:

```

function assignHandler() {
    let element = document.getElementById('someElement');
    element.onclick = () => console.log(element.id);
}

```

This code creates a closure as an event handler on `element`, which in turn creates a circular reference (events are discussed in Chapter 13). The anonymous function keeps a reference to the `assignHandler()` function's activation object, which prevents the reference count for `element` from being decremented. As long as the anonymous function exists, the reference count for `element` will be at least 1, which means the memory will never be reclaimed. This situation can be remedied by changing the code slightly, as shown here:

```

function assignHandler() {
    let element = document.getElementById('someElement');
    let id = element.id;

    element.onclick = () => console.log(id);

    element = null;
}

```

In this version of the code, a copy of `element`'s ID is stored in a variable that is used in the closure, eliminating the circular reference. That step alone is not enough, however, to prevent the memory problem. Remember that the closure has a reference to the containing function's entire activation

object, which contains `element`. Even if the closure doesn't reference `element` directly, a reference is still stored in the containing function's activation object. It is necessary, therefore, to set the `element` variable equal to `null`. This dereferences the COM object and decrements its reference count, ensuring that the memory can be reclaimed when appropriate.

IMMEDIATELY INVOKED FUNCTION EXPRESSIONS

An anonymous function that is called immediately is most often called an *immediately invoked function expression (IIFE)*. It resembles a function declaration, but because it is enclosed in parentheses it is interpreted as a function expression. This function is then called via the second set of parentheses at the end. The basic syntax is as follows:

```
(function() {
  // block code here
}) ();
```

The use of an IIFE to simulate block scope uses values defined inside a function expression that is executed immediately, thereby offering a block scope–like behavior using function scoped variables. (The utility of the IIFE was much greater in previous versions of ECMAScript 6 where block scoped variables were not supported.) Consider the following example:

```
// IIFE
(function () {
  for (var i = 0; i < count; i++) {
    console.log(i);
  }
}) ();

console.log(i); // Throws an error
```

The preceding code will error when the `console.log()` outside the IIFE attempts to execute because the variable defined inside the IIFE is not scoped to be accessible from outside the function expression. When trying to prevent variable bleed in ECMAScript 5.1 or before, this is a very useful pattern. It also limits the closure memory problem because there is no reference to the anonymous function. Therefore, the scope chain can be destroyed immediately after the function has completed.

With ECMAScript 6, the IIFE is no longer required for emulating block scope, as block scoped variables will offer the exact same behavior without the need for an IIFE (shown here in two different ways):

```
// Inline block scope
{
  let i;
  for (i = 0; i < count; i++) {
    console.log(i);
  }
}

console.log(i); // Throws an error
```

```
// Function block scope
for (let i = 0; i < count; i++) {
  console.log(i);
}

console.log(i); // Throws an error
```

A canonical example demonstrating the utility of the IIFE involved its ability to freeze parameter values. Consider the following example:

```
let divs = document.querySelectorAll('div');

// Does not work!
for (var i = 0; i < divs.length; ++i) {
  divs[i].addEventListener('click', function() {
    console.log(i);
  });
}
```

This uses the `var` keyword to declare the loop iterator, which is not restricted to the loop's block scope. With this presentation, clicking each `<div>` will alert the total number of elements because the counter variable still exists when the click handler executes.

Formerly, the solution to this was to use an IIFE to execute a function expression immediately that is passed the current value of the counter, thereby "freezing" the value of the counter when the click handler is defined:

```
let divs = document.querySelectorAll('div');

for (var i = 0; i < divs.length; ++i) {
  divs[i].addEventListener('click', (function(frozenCounter) {
    return function() {
      console.log(frozenCounter);
    };
  })(i));
}
```

This, however, is unnecessary with the introduction of ECMAScript block scoped variables:

```
let divs = document.querySelectorAll('div');

for (let i = 0; i < divs.length; ++i) {
  divs[i].addEventListener('click', function() {
    console.log(i);
  });
}
```

This will properly alert the corresponding index with each click. Here, the event handler executing will reference the value of the counter inside the `for` loop. In ECMAScript 6, a `for` loop using a block scoped variable keyword—here, `let`—for the iterator will create a separate counter instance per iteration, thereby allowing each click handler to reference that specific counter when executing.

Importantly, note that this will not happen when that variable is pulled outside the `for` loop. The following will experience the same problem as using `var i = 0` inside the loop:

```
let divs = document.querySelectorAll('div');

// Does not work
let i;
for (i = 0; i < divs.length; ++i) {
  divs[i].addEventListener('click', function() {
    console.log(i);
  });
}
```

PRIVATE VARIABLES

Strictly speaking, JavaScript has no concept of private members; all object properties are public. There is, however, a concept of *private variables*. Any variable defined inside a function or block is considered private because it is inaccessible outside that function. This includes function arguments, local variables, and functions defined inside other functions. Consider the following:

```
function add(num1, num2) {
  let sum = num1 + num2;
  return sum;
}
```

In this function, there are three private variables: `num1`, `num2`, and `sum`. These variables are accessible inside the function but can't be accessed outside it. If a closure were to be created inside this function, it would have access to these variables through its scope chain. Using this knowledge, you can create public methods that have access to private variables.

A *privileged method* is a public method that has access to private variables and/or private functions. There are two ways to create privileged methods on objects. The first is to do so inside a constructor, as in this example:

```
function MyObject() {
  // private variables and functions
  let privateVariable = 10;

  function privateFunction() {
    return false;
  }

  // privileged methods
  this.publicMethod = function() {
    privateVariable++;
    return privateFunction();
  };
}
```

This pattern defines all private variables and functions inside the constructor. Then privileged methods can be created to access those private members. This works because the privileged methods, when defined in the constructor, become closures with full access to all variables and functions defined inside the constructor's scope. In this example, the variable `privateVariable` and the function

`privateFunction()` are accessed only by `publicMethod()`. Once an instance of `MyObject` is created, there is no way to access `privateVariable` and `privateFunction()` directly; you can do so only by way of `publicMethod()`.

You can define private and privileged members to hide data that should not be changed directly, as in this example:

```
function Person(name) {
  this.getName = function() {
    return name;
  };

  this.setName = function (value) {
    name = value;
  };
}

let person = new Person('Nicholas');
console.log(person.getName()); // 'Nicholas'
person.setName('Greg');
console.log(person.getName()); // 'Greg'
```

The constructor in this code defines two privileged methods: `getName()` and `setName()`. Each method is accessible outside the constructor and accesses the private `name` variable. Outside the `Person` constructor, there is no way to access `name`. Because both methods are defined inside the constructor, they are closures and have access to `name` through the scope chain. The private variable `name` is unique to each instance of `Person` because the methods are being re-created each time the constructor is called. One downside, however, is that you must use the constructor pattern to accomplish this result. As discussed in the *Objects, Classes, and Object-Oriented Programming* chapter, the constructor pattern is flawed in that new methods are created for each instance. Using static private variables to achieve privileged methods enables the user to avoid this problem.

Static Private Variables

Privileged methods can also be created by using a private scope to define the private variables or functions. The pattern is as follows:

```
(function() {
  // private variables and functions
  let privateVariable = 10;

  function privateFunction() {
    return false;
  }

  // constructor
  MyObject = function() {};

  // public and privileged methods
  MyObject.prototype.publicMethod = function() {
    privateVariable++;
    return privateFunction();
  };
})();
```

In this pattern, a private scope is created to enclose the constructor and its methods. The private variables and functions are defined first, followed by the constructor and the public methods. Public methods are defined on the prototype, as in the typical prototype pattern. Note that this pattern defines the constructor not by using a function declaration but instead by using a function expression. Function declarations always create local functions, which is undesirable in this case. For this same reason, a variable declaration keyword is not used with `MyObject`. Remember that initializing an undeclared variable always creates a global variable, so `MyObject` becomes global and available outside the private scope. Also keep in mind that assigning to an undeclared variable in strict mode causes an error.

The main difference between this pattern and the previous one is that private variables and functions are shared among instances. Because the privileged method is defined on the prototype, all instances use that same function. The privileged method, being a closure, always holds a reference to the containing scope. Consider the following:

```
(function() {
  let name = '';

  Person = function(value) {
    name = value;
  };

  Person.prototype.getName = function() {
    return name;
  };

  Person.prototype.setName = function(value) {
    name = value;
  };
})();

let person1 = new Person('Nicholas');
console.log(person1.getName()); // 'Nicholas'
person1.setName('Matt');
console.log(person1.getName()); // 'Matt'

let person2 = new Person('Michael');
console.log(person1.getName()); // 'Michael'
console.log(person2.getName()); // 'Michael'
```

The `Person` constructor in this example has access to the private variable `name`, as do the `getName()` and `setName()` methods. Using this pattern, the `name` variable becomes static and will be used among all instances. This means calling `setName()` on one instance affects all other instances. Calling `setName()` or creating a new `Person` instance sets the `name` variable to a new value. This causes all instances to return the same value.

Creating static private variables in this way allows for better code reuse through prototypes, although each instance doesn't have its own private variable. Ultimately, the decision to use instance or static private variables needs to be based on your individual requirements.

NOTE *The farther up the scope chain a variable lookup is, the slower the lookup becomes because of the use of closures and private variables.*

The Module Pattern

The previous patterns create private variables and privileged methods for custom types. The module pattern, as described by Douglas Crockford, does the same for singletons. Singletons are objects of which there will only ever be one instance. Traditionally, singletons are created in JavaScript using object literal notation, as shown in the following example:

```
let singleton = {
  name: value,
  method() {
    // method code here
  }
};
```

The module pattern augments the basic singleton to allow for private variables and privileged methods, taking the following format:

```
let singleton = function() {
  // private variables and functions
  let privateVariable = 10;

  function privateFunction() {
    return false;
  }

  // privileged/public methods and properties
  return {
    publicProperty: true,

    publicMethod() {
      privateVariable++;
      return privateFunction();
    }
  };
}();
```

The module pattern uses an anonymous function that returns an object. Inside of the anonymous function, the private variables and functions are defined first. After that, an object literal is returned as the function value. That object literal contains only properties and methods that should be public. Because the object is defined inside the anonymous function, all of the public methods have access to the private variables and functions. Essentially, the object literal defines the public interface for the singleton. This can be useful when the singleton requires some sort of initialization and access to private variables, as in this example:

```
let application = function() {
  // private variables and functions
  let components = new Array();

  // initialization
  components.push(new BaseComponent());

  // public interface
  return {
    getComponentCount() {
      return components.length;
    },
  },
};
```

```
    registerComponent(component) {  
      if (typeof component == 'object') {  
        components.push(component);  
      }  
    }  
  };  
}();
```

In web applications, it's quite common to have a singleton that manages application-level information. This simple example creates an `application` object that manages components. When the object is first created, the private `components` array is created and a new instance of `BaseComponent` is added to its list. (The code for `BaseComponent` is not important; it is used only to show initialization in the example.) The `getComponentCount()` and `registerComponent()` methods are privileged methods with access to the `components` array. The former simply returns the number of registered components, and the latter registers a new component.

The module pattern is useful for cases such as when a single object is created, initialized with some data, and then needs to expose public methods that have access to private data. Every singleton created in this manner is an instance of `Object` because ultimately an object literal represents it. This is inconsequential because singletons are typically accessed globally instead of passed as arguments into a function, which negates the need to use the `instanceof` operator to determine the object type.

The Module-Augmentation Pattern

Another take on the module pattern calls for the augmentation of the object before returning it. This pattern is useful when the singleton object needs to be an instance of a particular type but must be augmented with additional properties and/or methods. Consider the following example:

```
let singleton = function() {  
  // private variables and functions  
  let privateVariable = 10;  
  
  function privateFunction() {  
    return false;  
  }  
  
  // create object  
  let object = new CustomType();  
  
  // add privileged/public properties and methods  
  object.publicProperty = true;  
  
  object.publicMethod = function() {  
    privateVariable++;  
    return privateFunction();  
  };  
  
  // return the object  
  return object;  
}();
```

If the application object in the module pattern example had to be an instance of `BaseComponent`, the following code could be used:

```
let application = function() {
  // private variables and functions
  let components = new Array();

  // initialization
  components.push(new BaseComponent());

  // create a local copy of application
  let app = new BaseComponent();

  // public interface
  app.getComponentCount = function() {
    return components.length;
  };

  app.registerComponent = function(component) {
    if (typeof component == "object") {
      components.push(component);
    }
  };

  // return it
  return app;
}();
```

In this rewritten version of the application singleton, the private variables are defined first, as in the previous example. The main difference is the creation of a variable named `app` that is a new instance of `BaseComponent`. This is the local version of what will become the `application` object. Public methods are then added onto the `app` object to access the private variables. The last step is to return the `app` object, which assigns it to `application`.

SUMMARY

Functions are useful and versatile tools in JavaScript programming. ECMAScript 6 introduces powerful syntax allowing you to wield them even more effectively.

- Function expressions are different from function declarations. Function declarations require names, while function expressions do not. A function expression without a name is also called an anonymous function.
- New in ES6, arrow functions are similar to function expressions, but with some important differences.
- Arguments and parameters in JavaScript functions are highly flexible. The `arguments` object, along with the new spread operator in ES6, allow for totally dynamic definition and invocation.
- Internally, functions expose a handful of objects and references that provide you information on how the function was invoked, where it was invoked, and what was originally passed to it.

- Engines will optimize functions with tail calls to preserve stack space.
- Behind the scenes, the closure's scope chain contains a variable object for itself, the containing function, and the global context.
- Typically, a function's scope and all of its variables are destroyed when the function has finished executing.
- When a closure is returned from that function, its scope remains in memory until the closure no longer exists.
- A function can be created and called immediately, executing the code within it but never leaving a reference to the function.
- This results in all of the variables inside the function being destroyed unless they are specifically set to a variable in the containing scope.
- Even though JavaScript doesn't have a formal concept of private object properties, closures can be used to implement public methods that have access to variables defined within the containing scope.
- Public methods that have access to private variables are called privileged methods.
- Privileged methods can be implemented on custom types using the constructor or prototype patterns and on singletons by using the module or module-augmentation patterns.

11

Promises and Async Functions

WHAT'S IN THIS CHAPTER?

- Introduction to Asynchronous Programming
- Promises
- Async Functions

WROX.COM DOWNLOADS FOR THIS CHAPTER

Please note that all the code examples for this chapter are available as a part of this chapter's code download on the book's website at www.wrox.com/go/projavascript4e on the Download Code tab.

In ECMAScript editions beginning with ES6, support and tooling for asynchronous behavior has undergone a renaissance. ECMAScript 6 introduces a formal `Promise` reference type, allowing for elegant definition and organization of asynchronous behavior. Later editions also extended the language to support asynchronous functions with the `async` and `await` keywords.

NOTE *Throughout this chapter, examples make extensive use of asynchronous logging `setTimeout(console.log, 0, ...params)` to demonstrate order of operation and other asynchronous behavior characteristics. The log output will be shown as though it is printed synchronously when, in fact, it is printed asynchronously. This is done to allow for values such as promises to assume their final state.*

Additionally, a browser's console output will often print information about objects that is not otherwise available to the JavaScript runtime (such as the state of a promise). This feature is used extensively in examples throughout the chapter to aid in broadening the reader's understanding.

INTRODUCTION TO ASYNCHRONOUS PROGRAMMING

The duality between synchronous and asynchronous behavior is a fundamental concept in computer science—especially in a single-threaded event loop model such as JavaScript. Asynchronous behavior is borne out of the need to optimize for higher computational throughput in the face of high-latency operations. If it is feasible to run other instructions while a computation is completing and still maintain a stable system, then it is pragmatic to do so.

Importantly, an asynchronous operation is not necessarily a computationally intensive or high-latency operation. It can be used anywhere it doesn't make sense to block a thread of execution to wait for the asynchronous behavior to occur.

Synchronous vs. Asynchronous JavaScript

Synchronous behavior is analogous to sequential processor instructions in memory. Each instruction is executed strictly in the order in which it appears, and each is also capable of immediately retrieving information that is stored locally within the system (for example: in a processor register or in system memory). As a result, it is easy to reason about the program state (for example, the value of a variable) at any given point in code.

A trivial example of this would be performing a simple arithmetic operation:

```
let x = 3;  
x = x + 4;
```

At each step in this program, it is possible to reason about the state of the program because execution will not proceed until the previous instruction is completed. When the last instruction completes, the computed value of `x` is immediately available for use.

This JavaScript snippet is easy to reason about because it is not difficult to anticipate what low-level instructions this will be compiled to (from JavaScript to x86, for example). Presumably, the operating system will allocate some memory for a floating point number on the stack, perform an arithmetic operation on that value, and write the result to that allocated memory. All of these instructions exist serially inside a single thread of execution. At each point in the compiled low-level program, you are well-equipped to assert what can and cannot be known about the state of the system.

Conversely, *asynchronous behavior* is analogous to interrupts, where an entity external to the current process is able to trigger code execution. An asynchronous operation is often required because it is infeasible to force the process to wait a long time for an operation to complete (which is the case with a synchronous operation). This long wait might occur because the code is accessing a high-latency resource, such as sending a request to a remote server and awaiting a response.

A trivial JavaScript example of this would be performing an arithmetic operation inside a timeout:

```
let x = 3;  
setTimeout(() => x = x + 4, 1000);
```

This program eventually performs the same work as the synchronous one—adding two numbers together—but this thread of execution cannot know exactly when the value of `x` will change because that depends on when the callback is dequeued from the message queue and executed.

This code is not as easy to reason about. Although the low-level instructions used in this example ultimately do the same work as the previous example, the second chunk of instructions (the addition

operation and assignment) are triggered by a system timer, which will generate an interrupt to enqueue execution. Precisely when this interrupt will be triggered is a black box to the JavaScript runtime, so it effectively cannot be known exactly when the interrupt will occur (although it is guaranteed to be *after* the current thread of synchronous execution completes, since the callback will not yet have had an opportunity to be dequeued and executed). Nevertheless, you are generally unable to assert when the system state will change after the callback is scheduled.

For the value of `x` to become useful, this asynchronously executed function would need to signal to the rest of the program that it has updated the value of `x`. However, if the program does not need this value, then it is free to proceed and do other work instead of waiting for the result.

Designing a system to know when the value of `x` can be read is surprisingly tricky. Implementations of such a system within the JavaScript have undergone several iterations.

Legacy Asynchronous Programming Patterns

Asynchronous behavior has long been an important but ugly cornerstone of JavaScript. In early versions of the language, an asynchronous operation only supported definition of a callback function to indicate that the asynchronous operation had completed. Serializing asynchronous behavior was a common problem, usually solved by a codebase full of nested callback functions—colloquially referred to as “callback hell.”

Suppose you were working with the following asynchronous function, which uses `setTimeout` to perform some behavior after one second:

```
function double(value) {
  setTimeout(() => setTimeout(console.log, 0, value * 2), 1000);
}

double(3);
// 6 (printed after roughly 1000ms)
```

There's nothing mysterious occurring here, but it is important to understand exactly why this is an asynchronous function. `setTimeout` allows for the definition of a callback that is scheduled to execute after a specified amount of time. After 1000ms, the JavaScript runtime will schedule the callback for execution by pushing it onto JavaScript's message queue. This callback is dequeued and executed in a manner that is totally invisible to JavaScript code. What's more, the `double()` function exits immediately after the `setTimeout` scheduling operation is successful.

Returning Asynchronous Values

Suppose the `setTimeout` operation returned a useful value. What's the best way to transport the value back to where it is needed? The widely accepted strategy is to provide a callback to the asynchronous operation, where the callback contained the code that needs access to the calculated value (provided as a parameter). This looks like the following:

```
function double(value, callback) {
  setTimeout(() => callback(value * 2), 1000);
}

double(3, (x) => console.log(`I was given: ${x}`));
// I was given: 6 (printed after roughly 1000ms)
```

Here, the `setTimeout` invocation is instructed to push a function onto the message queue after 1000ms have elapsed. This function will be dequeued and asynchronously evaluated by the runtime. The callback function and its parameters are still available in the asynchronous execution through a function closure.

Handling Failure

The possibility of failure needs to be incorporated into this callback model as well, so this typically took the form of a success and failure callback:

```
function double(value, success, failure) {
  setTimeout(() => {
    try {
      if (typeof value !== 'number') {
        throw 'Must provide number as first argument';
      }
      success(2 * value);
    } catch (e) {
      failure(e);
    }
  }, 1000);
}

const successCallback = (x) => console.log(`Success: ${x}`);
const failureCallback = (e) => console.log(`Failure: ${e}`);

double(3, successCallback, failureCallback);
double('b', successCallback, failureCallback);

// Success: 6 (printed after roughly 1000ms)
// Failure: Must provide number as first argument (printed after roughly 1000ms)
```

This format is already undesirable, as the callbacks must be defined when the asynchronous operation is initialized. The value returned from the asynchronous function is transient, and so only callbacks that are prepared to accept this transient value as a parameter are capable of accessing it.

Nesting Asynchronous Callbacks

The callback situation is further complicated when access to the asynchronous values have dependencies on other asynchronous values. In the world of callbacks, this necessitates nesting the callbacks:

```
function double(value, success, failure) {
  setTimeout(() => {
    try {
      if (typeof value !== 'number') {
        throw 'Must provide number as first argument';
      }
      success(2 * value);
    } catch (e) {
      failure(e);
    }
  }, 1000);
}
```

```

const successCallback = (x) => {
  double(x, (y) => console.log(`Success: ${y}`));
};
const failureCallback = (e) => console.log(`Failure: ${e}`);

double(3, successCallback, failureCallback);

// Success: 12 (printed after roughly 1000ms)

```

It should come as no surprise that this callback strategy does not scale well as code complexity grows. The “callback hell” colloquialism is well-deserved, as JavaScript codebases that were afflicted with such a structure became nearly unmaintainable.

PROMISES

A “promise” is a surrogate entity that acts as a stand-in for a result that does not yet exist. The term “promise” was first proposed by Daniel Friedman and David Wise in their 1976 paper, *The Impact of Applicative Programming on Multiprocessing*, but the conceptual behavior of a promise would not be formalized until a decade later by Barbara Liskov and Liuba Shrira in their 1988 paper, *Promises: Linguistic Support for Efficient Asynchronous Procedure Calls in Distributed Systems*. Contemporary computer scientists described similar concepts such as an “eventual,” “future,” “delay,” or “deferred”; all of these described in one form or another a programming tool for synchronizing program execution.

The Promises/A+ Specification

Early forms of promises appeared in jQuery and Dojo’s Deferred API, and in 2010, growing popularity led to the Promises/A specification inside the CommonJS project. Third-party JavaScript promise libraries such as Q and Bluebird continued to gain adoption, yet each implementation was slightly different. To address the rifts in the promise space, in 2012 the Promises/A+ organization forked the CommonJS “Promises/A” proposal and created the eponymous Promises/A+ Promise Specification (<https://promisesaplus.com/>). This specification would eventually govern how promises were implemented in the ECMAScript 6 specification.

ECMAScript 6 introduced a first-class implementation of a Promises/A+–compliant Promise type. In the time since its introduction, Promises have enjoyed an overwhelmingly robust rate of adoption. All modern browsers fully support the ES6 promise type, and multiple browser APIs such as `fetch()` and the battery API use it exclusively.

Promise Basics

As of ECMAScript 6, `Promise` is a supported reference type and can be instantiated with the `new` operator. Doing so requires passing an executor function parameter (covered in an upcoming section), which here is an empty function object to please the interpreter:

```

let p = new Promise(() => {});
setTimeout(console.log, 0, p); // Promise <pending>

```

If an executor function is not provided, a `SyntaxError` will be thrown.

The Promise State Machine

When passing a promise instance to `console.log`, the console output (which may vary between browsers) indicates that this promise instance is *pending*. As mentioned previously, a promise is a stateful object that can exist in one of three states:

- *Pending*
- *Fulfilled* (sometimes also referred to as *resolved*)
- *Rejected*

A *pending* state is the initial state a promise begins in. From a pending state, a promise can become *settled* by transitioning to a *fulfilled* state to indicate success, or a *rejected* state to indicate failure. This transition to a *settled* state is irreversible; once a transition to either *fulfilled* or *rejected* occurs, the state of the promise can never change. Furthermore, it is not guaranteed that a promise will ever leave the *pending* state. Therefore, well-structured code should behave properly if the promise successfully resolves, if the promise rejects, or if it never exits the pending state.

Importantly, the state of a promise is private and cannot be directly inspected in JavaScript. The reason for this is primarily to prevent synchronous programmatic handling of a promise object based on its state when it is read. Furthermore, the state of a promise cannot be mutated by external JavaScript. This is for the same reason the state cannot be read: The promise intentionally encapsulates a block of asynchronous behavior, and external code performing synchronous definition of its state would be antithetical to its purpose.

Resolved Values, Rejection Reasons, and Utility of Promises

There are two primary reasons the Promise construct is useful. The first is to abstractly represent a block of asynchronous execution. The state of the promise is indicative of whether or not the promise has yet to complete execution. The *pending* state indicates that execution has not yet begun or is still in progress. The *fulfilled* state is a nonspecific indicator that the execution has completed successfully. The *rejected* state is a nonspecific indicator that the execution did not complete successfully.

In some cases, the internal state machine is all the utility a promise needs to provide: the mere knowledge that a piece of asynchronous code has completed is sufficient for informing program flow. For example, suppose a promise is dispatching an HTTP request to a server. The request returning with a status of 200–299 might be sufficient to transition the promise state to *fulfilled*. Similarly, the request returning with a status that is *not* 200–299 would transition the promise state to *rejected*.

In other cases, the asynchronous execution that the promise is wrapping is actually generating a value, and the program flow will expect this value to be available when the promise changes state. Alternately, if the promise rejects, the program flow will expect the reason for rejection when the promise changes state. For example, suppose a promise is dispatching an HTTP request to a server and expecting it to return JSON. The request returning with a status of 200–299 might be sufficient to transition the promise to *fulfilled*, and the JSON string will be available inside the promise. Similarly, the request returning with a status that is *not* 200–299 would transition the promise state to *rejected*, and the reason for rejection might be an `ERROR` object containing the text accompanying the HTTP status code.

To support these two use cases, every promise that transitions to a *fulfilled* state has a private internal *value*. Similarly, every promise that transitions to a *rejected* state has a private internal *reason*. Both *value* and *reason* are an immutable reference to a primitive or object. Both are optional and will default to `undefined`. Asynchronous code that is scheduled to execute after a promise reaches a certain *settled* state is always provided with the *value* or *reason*.

Controlling Promise State with the Executor

Because the state of a promise is private, it can only be manipulated internally. This internal manipulation is performed inside the promise's executor function. The executor function has two primary duties: initializing the asynchronous behavior of the promise, and controlling any eventual state transition. Control of the state transition is accomplished by invoking one of its two function parameters, typically named `resolve` and `reject`. Invoking `resolve` will change the state to *fulfilled*; invoking `reject` will change the state to *rejected*. Invoking `rejected()` will also throw an error (this error behavior is covered more later).

```
let p1 = new Promise((resolve, reject) => resolve());
setTimeout(console.log, 0, p1); // Promise <resolved>

let p2 = new Promise((resolve, reject) => reject());
setTimeout(console.log, 0, p2); // Promise <rejected>
// Uncaught error (in promise)
```

In the preceding example, there isn't really any asynchronous behavior occurring because the state of each promise is already changed by the time the executor function exits. Importantly, the executor function will execute *synchronously*, as it acts as the initializer for the promise. This order of execution is demonstrated here:

```
new Promise(() => setTimeout(console.log, 0, 'executor'));
setTimeout(console.log, 0, 'promise initialized');

// executor
// promise initialized
```

You can delay the state transition by adding a `setTimeout`:

```
let p = new Promise((resolve, reject) => setTimeout(resolve, 1000));

// When this console.log executes, the timeout callback has not yet executed:
setTimeout(console.log, 0, p); // Promise <pending>
```

Once either `resolve` or `reject` is invoked, the state transition cannot be undone. Attempts to further mutate the state will silently be ignored. This is demonstrated here:

```
let p = new Promise((resolve, reject) => {
  resolve();
  reject(); // No effect
});

setTimeout(console.log, 0, p); // Promise <resolved>
```

You can avoid promises getting stuck in a pending state by adding timed exit behavior. For example, you can set a timeout to reject the promise after 10 seconds:

```
let p = new Promise((resolve, reject) => {
  setTimeout(reject, 10000); // After 10 seconds, invoke reject()
```

```
    // Do executor things
  });

  setTimeout(console.log, 0, p);    // Promise <pending>
  setTimeout(console.log, 11000, p); // Check state after 11 seconds

  // (After 10 seconds) Uncaught error
  // (After 11 seconds) Promise <rejected>
```

Because a promise can only change state a single time, this timeout behavior allows you to safely set a maximum on the amount of time a promise can remain in the pending state. If the code inside the executor were to resolve or reject prior to the timeout, the timeout handler's attempt to reject the promise will be silently ignored.

Promise Casting with `Promise.resolve()`

A promise does not necessarily need to begin in a pending state and utilize an executor function to reach a settled state. It is possible to instantiate a promise in the "resolved" state by invoking the `Promise.resolve()` static method. The following two promise instantiations are effectively equivalent:

```
let p1 = new Promise((resolve, reject) => resolve());
let p2 = Promise.resolve();
```

The value of this resolved promise will become the first argument passed to `Promise.resolve()`. This effectively allows you to "cast" any value into a promise:

```
setTimeout(console.log, 0, Promise.resolve());
// Promise <resolved>: undefined

setTimeout(console.log, 0, Promise.resolve(3));
// Promise <resolved>: 3

// Additional arguments are ignored
setTimeout(console.log, 0, Promise.resolve(4, 5, 6));
// Promise <resolved>: 4
```

Perhaps the most important aspect of this static method is its ability to act as a passthrough when the argument is already a promise. As a result, `Promise.resolve()` is an idempotent method, as demonstrated here:

```
let p = Promise.resolve(7);

setTimeout(console.log, 0, p === Promise.resolve(p));
// true

setTimeout(console.log, 0, p === Promise.resolve(Promise.resolve(p)));
// true
```

This idempotence will respect the state of the promise passed to it:

```
let p = new Promise(() => {});

setTimeout(console.log, 0, p); // Promise <pending>
setTimeout(console.log, 0, Promise.resolve(p)); // Promise <pending>

setTimeout(console.log, 0, p === Promise.resolve(p)); // true
```

Beware that this static method will happily wrap any non-promise, including an error object, as a resolved promise, which might lead to unintended behavior:

```
let p = Promise.resolve(new Error('foo'));

setTimeout(console.log, 0, p);
// Promise <resolved>: Error: foo
```

Promise Rejection with Promise.reject()

Similar in concept to `Promise.resolve()`, `Promise.reject()` instantiates a rejected promise and throws an asynchronous error (which will not be caught by `try/catch` and can only be caught by a rejection handler). The following two promise instantiations are effectively equivalent:

```
let p1 = new Promise((resolve, reject) => reject());
let p2 = Promise.reject();
```

The ‘reason’ field of this resolved promise will be the first argument passed to `Promise.reject()`. This will also be the error passed to the reject handler:

```
let p = Promise.reject(3);
setTimeout(console.log, 0, p); // Promise <rejected>: 3

p.then(null, (e) => setTimeout(console.log, 0, e)); // 3
```

Importantly, `Promise.reject()` does not mirror the behavior of `Promise.resolve()` with respect to idempotence. If passed a promise object, it will happily use that promise as the ‘reason’ field of the rejected promise:

```
setTimeout(console.log, 0, Promise.reject(Promise.resolve()));
// Promise <rejected>: Promise <resolved>
```

Synchronous/Asynchronous Execution Duality

Much of the design of the `Promise` construct is to engender a totally separate mode of computation in JavaScript. This is neatly encapsulated in the following example, which throws errors in two different ways:

```
try {
  throw new Error('foo');
} catch(e) {
  console.log(e); // Error: foo
}

try {
  Promise.reject(new Error('bar'));
} catch(e) {
  console.log(e);
}
// Uncaught (in promise) Error: bar
```

The first `try/catch` block throws an error and then proceeds to catch it, but the second `try/catch` block throws an error that is *not* caught. This might seem counterintuitive because the code appears to be synchronously creating a rejected promise instance, which then throws an error upon rejection. However, the reason the second promise is not caught is that the code is not attempting to catch the error

in the appropriate "asynchronous mode." Such behavior underscores how promises actually behave: They are synchronous objects—used inside a synchronous mode of execution—acting as a bridge to an *asynchronous* mode of execution.

In the preceding example, the error from the rejected promise is not being thrown inside the synchronous execution thread, but instead from the browser's asynchronous message queue execution. Therefore, the encapsulating try/catch block will not suffice to catch this error. Once code starts to execute in this asynchronous mode, the only way to interact with it is to use asynchronous mode constructs—more specifically, promise methods.

Promise Instance Methods

The methods exposed on a promise instance serve to bridge the gap between the synchronous external code path and the asynchronous internal code path. These methods can be used to access data returned from an asynchronous operation, handle success and failure outcomes of the promise, serially evaluate promises, or add functions that only execute once the promise enters a terminal state.

Implementing the Thenable Interface

For the purposes of ECMAScript asynchronous constructs, any object that exposes a `then()` method is considered to implement the `Thenable` interface. The following is an example of the simplest possible class that implements this interface:

```
class MyThenable {
  then() {}
}
```

The ECMAScript `Promise` type implements the `Thenable` interface. This simplistic interface is not to be confused with other interfaces or type definitions in packages like TypeScript, which lay out a much more specific form of a `Thenable` interface.

NOTE *The utility and purpose of the `Thenable` interface is revisited later in the chapter in the *async function* section.*

Promise.prototype.then()

The method `Promise.prototype.then()` is the primary method that is used to attach handlers to a promise instance. The `then()` method accepts up to two arguments: an optional `onResolved` handler function, and an optional `onRejected` handler function. Each will execute only when the promise upon which they are defined reaches its respective "fulfilled" or "rejected" state.

```
function onResolved(id) {
  setTimeout(console.log, 0, id, 'resolved');
}
function onRejected(id) {
  setTimeout(console.log, 0, id, 'rejected');
}
```

```

let p1 = new Promise((resolve, reject) => setTimeout(resolve, 3000));
let p2 = new Promise((resolve, reject) => setTimeout(reject, 3000));

p1.then(() => onResolved('p1'),
      () => onRejected('p1'));
p2.then(() => onResolved('p2'),
      () => onRejected('p2'));

// (after 3s)
// p1 resolved
// p2 rejected

```

Because a promise can only transition to a final state a single time, you are guaranteed that execution of these handlers is mutually exclusive.

As described earlier, both handler arguments are completely optional. Any non-function type provided as an argument to `then()` will be silently ignored. If you wish to explicitly provide only an `onRejected` handler, providing `undefined` as the `onResolved` argument is the canonical choice. This allows you to avoid creating a temporary object in memory just to be ignored by the interpreter, and it will also please type systems that expect an optional function object as an argument.

```

function onResolved(id) {
  setTimeout(console.log, 0, id, 'resolved');
}
function onRejected(id) {
  setTimeout(console.log, 0, id, 'rejected');
}

let p1 = new Promise((resolve, reject) => setTimeout(resolve, 3000));
let p2 = new Promise((resolve, reject) => setTimeout(reject, 3000));

// Non-function handlers are silently ignored, not recommended
p1.then('gobbeltgook');

// Canonical form of explicit onResolved handler skipping
p2.then(null, () => onRejected('p2'));

// p2 rejected (after 3s)

```

The `Promise.prototype.then()` method returns a new promise instance:

```

let p1 = new Promise(() => {});
let p2 = p1.then();
setTimeout(console.log, 0, p1);           // Promise <pending>
setTimeout(console.log, 0, p2);           // Promise <pending>
setTimeout(console.log, 0, p1 === p2);    // false

```

This new promise instance is derived from the return value of the `onResolved` handler. The return value of the handler is wrapped in `Promise.resolve()` to generate a new promise. If no handler function is provided, the method acts as a passthrough for the initial promise's resolved value. If there is no explicit return statement, the default return value is `undefined` and wrapped in a `Promise.resolve()`.

```

let p1 = Promise.resolve('foo');

// Calling then() with no handler function acts as a passthrough
let p2 = p1.then();

```

```
setTimeout(console.log, 0, p2); // Promise <resolved>: foo

// These are equivalent
let p3 = p1.then(() => undefined);
let p4 = p1.then(() => {});
let p5 = p1.then(() => Promise.resolve());

setTimeout(console.log, 0, p3); // Promise <resolved>: undefined
setTimeout(console.log, 0, p4); // Promise <resolved>: undefined
setTimeout(console.log, 0, p5); // Promise <resolved>: undefined
```

Explicit return values are wrapped in `Promise.resolve()`:

```
...

// These are equivalent:
let p6 = p1.then(() => 'bar');
let p7 = p1.then(() => Promise.resolve('bar'));

setTimeout(console.log, 0, p6); // Promise <resolved>: bar
setTimeout(console.log, 0, p7); // Promise <resolved>: bar

// Promise.resolve() preserves the returned promise
let p8 = p1.then(() => new Promise(() => {}));
let p9 = p1.then(() => Promise.reject());
// Uncaught (in promise): undefined

setTimeout(console.log, 0, p8); // Promise <pending>
setTimeout(console.log, 0, p9); // Promise <rejected>: undefined
```

Throwing an exception will return a rejected promise:

```
...

let p10 = p1.then(() => { throw 'baz'; });
// Uncaught (in promise) baz

setTimeout(console.log, 0, p10); // Promise <rejected> baz
```

Importantly, returning an error will not trigger the same rejection behavior, and will instead wrap the error object in a resolved promise:

```
...

let p11 = p1.then(() => Error('qux'));

setTimeout(console.log, 0, p11); // Promise <resolved>: Error: qux
```

The `onRejected` handler behaves in the same way: values returned from the `onRejected` handler are wrapped in `Promise.resolve()`. This might seem counterintuitive at first, but the `onRejected` handler is doing its job to catch an asynchronous error. Therefore, this rejection handler completing execution without throwing an additional error should be considered expected promise behavior and therefore return a resolved promise.

The following code snippet is the `Promise.reject()` analog of the previous examples using `Promise.resolve()`:

```
let p1 = Promise.reject('foo');

// Calling then() with no handler function acts as a passthrough
let p2 = p1.then();
// Uncaught (in promise) foo

setTimeout(console.log, 0, p2); // Promise <rejected>: foo

// These are equivalent
let p3 = p1.then(null, () => undefined);
let p4 = p1.then(null, () => {});
let p5 = p1.then(null, () => Promise.resolve());

setTimeout(console.log, 0, p3); // Promise <resolved>: undefined
setTimeout(console.log, 0, p4); // Promise <resolved>: undefined
setTimeout(console.log, 0, p5); // Promise <resolved>: undefined

// These are equivalent
let p6 = p1.then(null, () => 'bar');
let p7 = p1.then(null, () => Promise.resolve('bar'));

setTimeout(console.log, 0, p6); // Promise <resolved>: bar
setTimeout(console.log, 0, p7); // Promise <resolved>: bar

// Promise.resolve() preserves the returned promise
let p8 = p1.then(null, () => new Promise(() => {}));
let p9 = p1.then(null, () => Promise.reject());
// Uncaught (in promise): undefined

setTimeout(console.log, 0, p8); // Promise <pending>
setTimeout(console.log, 0, p9); // Promise <rejected>: undefined

let p10 = p1.then(null, () => { throw 'baz'; });
// Uncaught (in promise) baz

setTimeout(console.log, 0, p10); // Promise <rejected>: baz

let p11 = p1.then(null, () => Error('qux'));

setTimeout(console.log, 0, p11); // Promise <resolved>: Error: qux
```

Promise.prototype.catch()

The `Promise.prototype.catch()` method can be used to attach only a reject handler to a promise. It only takes a single argument, the `onRejected` handler function. The method is no more than syntactical sugar, and is no different than using `Promise.prototype.then(null, onRejected)`.

The following code demonstrates this equivalence:

```
let p = Promise.reject();
let onRejected = function(e) {
  setTimeout(console.log, 0, 'rejected');
};

// These two reject handlers behave identically:
p.then(null, onRejected); // rejected
p.catch(onRejected);      // rejected
```

The `Promise.prototype.catch()` method returns a new promise instance:

```
let p1 = new Promise(() => {});
let p2 = p1.catch();
setTimeout(console.log, 0, p1);           // Promise <pending>
setTimeout(console.log, 0, p2);           // Promise <pending>
setTimeout(console.log, 0, p1 === p2);    // false
```

With respect to creation of the new promise instance, `Promise.prototype.catch()` behaves identically to the `onRejected` handler of `Promise.prototype.then()`.

Promise.prototype.finally()

The `Promise.prototype.finally()` method can be used to attach an `onFinally` handler, which executes when the promise reaches either a resolved or a rejected state. This is useful for avoiding code duplication between `onResolved` and `onRejected` handlers. Importantly, the handler does not have any way of determining if the promise was resolved or rejected, so this method is designed to be used for things like cleanup.

```
let p1 = Promise.resolve();
let p2 = Promise.reject();
let onFinally = function() {
  setTimeout(console.log, 0, 'Finally!')
}

p1.finally(onFinally); // Finally
p2.finally(onFinally); // Finally
```

The `Promise.prototype.finally()` method returns a new promise instance:

```
let p1 = new Promise(() => {});
let p2 = p1.finally();
setTimeout(console.log, 0, p1);           // Promise <pending>
setTimeout(console.log, 0, p2);           // Promise <pending>
setTimeout(console.log, 0, p1 === p2);    // false
```

This new promise instance is derived in a different manner than `then()` or `catch()`. Because `onFinally` is intended to be a state-agnostic method, in most cases it will behave as a passthrough for the parent promise. This is true for both the resolved and rejected states.

```
let p1 = Promise.resolve('foo');

// These all act as a passthrough
let p2 = p1.finally();
let p3 = p1.finally(() => undefined);
```



```

let p4 = p1.finally(() => {});
let p5 = p1.finally(() => Promise.resolve());
let p6 = p1.finally(() => 'bar');
let p7 = p1.finally(() => Promise.resolve('bar'));
let p8 = p1.finally(() => Error('qux'));

setTimeout(console.log, 0, p2); // Promise <resolved>: foo
setTimeout(console.log, 0, p3); // Promise <resolved>: foo
setTimeout(console.log, 0, p4); // Promise <resolved>: foo
setTimeout(console.log, 0, p5); // Promise <resolved>: foo
setTimeout(console.log, 0, p6); // Promise <resolved>: foo
setTimeout(console.log, 0, p7); // Promise <resolved>: foo
setTimeout(console.log, 0, p8); // Promise <resolved>: foo

```

The only exceptions to this are when it returns a pending promise, or an error is thrown (via an explicit throw or returning a rejected promise). In these cases, the corresponding promise is returned (pending or rejected), as shown here:

```

...

// Promise.resolve() preserves the returned promise
let p9 = p1.finally(() => new Promise(() => {}));
let p10 = p1.finally(() => Promise.reject());
// Uncaught (in promise): undefined

setTimeout(console.log, 0, p9); // Promise <pending>
setTimeout(console.log, 0, p10); // Promise <rejected>: undefined

let p11 = p1.finally(() => { throw 'baz';});
// Uncaught (in promise) baz

setTimeout(console.log, 0, p11); // Promise <rejected>: baz

```

Returning a pending promise is an unusual case, as once the promise resolves, the new promise will still behave as a passthrough for the initial promise:

```

let p1 = Promise.resolve('foo');

// The resolved value is ignored
let p2 = p1.finally(
  () => new Promise((resolve, reject) => setTimeout(() => resolve('bar'), 100)));

setTimeout(console.log, 0, p2); // Promise <pending>

setTimeout(() => setTimeout(console.log, 0, p2), 200);

// After 200ms:
// Promise <resolved>: foo

```

Non-Reentrant Promise Methods

When a promise reaches a settled state, execution of handlers associated with that state are merely *scheduled* rather than immediately executed. Synchronous code following the attachment of the handler is guaranteed to execute before the handler is invoked. This remains true even if the promise already exists in the state the newly attached handler is associated with. This property, called

non-reentrancy, is guaranteed by the JavaScript runtime. The following simple example demonstrates this property:

```
// Create a resolved promise
let p = Promise.resolve();

// Attach a handler to the resolved state.
// Intuitively, this would execute as soon as possible since p is already resolved.
p.then(() => console.log('onResolved handler'));

// Synchronously log to indicate that then() has returned
console.log('then() returns');

// Actual output:
// then() returns
// onResolved handler
```

In this example, calling `then()` on a resolved promise will push the `onResolved` handler onto the message queue. This handler will not be executed until it is dequeued after the current thread of execution completes. Therefore, synchronous code immediately following `then()` is guaranteed to execute prior to the handler.

The inverse of this scenario yields the same result. If handlers are already attached to a promise that later synchronously changes state, the handler execution is non-reentrant upon that state change. The following example demonstrates how, even with an `onResolved` handler already attached, synchronously invoking `resolve()` will still exhibit non-reentrant behavior:

```
let synchronousResolve;

// Create a promise and capture the resolve function in a local variable
let p = new Promise((resolve) => {
  synchronousResolve = function() {
    console.log('1: invoking resolve()');
    resolve();
    console.log('2: resolve() returns');
  };
});

p.then(() => console.log('4: then() handler executes'));

synchronousResolve();
console.log('3: synchronousResolve() returns');

// Actual output:
// 1: invoking resolve()
// 2: resolve() returns
// 3: synchronousResolve() returns
// 4: then() handler executes
```

In this example, even though the promise state changes synchronously with handlers attached to that state, the handler execution will still not occur until dequeued from the runtime's message queue.

Non-reentrancy is guaranteed for both `onResolved` and `onRejected` handlers, `catch()` handlers, and `finally()` handlers. Each of these is demonstrated in this example:

```
let p1 = Promise.resolve();
p1.then(() => console.log('p1.then() onResolved'));
console.log('p1.then() returns');

let p2 = Promise.reject();
p2.then(null, () => console.log('p2.then() onRejected'));
console.log('p2.then() returns');

let p3 = Promise.reject();
p3.catch(() => console.log('p3.catch() onRejected'));
console.log('p3.catch() returns');

let p4 = Promise.resolve();
p4.finally(() => console.log('p4.finally() onFinally'));

console.log('p4.finally() returns');

// p1.then() returns
// p2.then() returns
// p3.catch() returns
// p4.finally() returns
// p1.then() onResolved
// p2.then() onRejected
// p3.catch() onRejected
// p4.finally() onFinally
```

Sibling Handler Order of Execution

If multiple handlers are attached to a promise, when the promise transitions to a settled state, the associated handlers will execute in the order in which they were attached. This is true for `then()`, `catch()`, and `finally()`:

```
let p1 = Promise.resolve();
let p2 = Promise.reject();

p1.then(() => setTimeout(console.log, 0, 1));
p1.then(() => setTimeout(console.log, 0, 2));
// 1
// 2

p2.then(null, () => setTimeout(console.log, 0, 3));
p2.then(null, () => setTimeout(console.log, 0, 4));
// 3
// 4

p2.catch(() => setTimeout(console.log, 0, 5));
p2.catch(() => setTimeout(console.log, 0, 6));
// 5
// 6

p1.finally(() => setTimeout(console.log, 0, 7));
p1.finally(() => setTimeout(console.log, 0, 8));
// 7
// 8
```

Resolved Value and Rejected Reason Passing

When reaching a settled state, a promise will provide its resolved value (if it is fulfilled) or its rejection reason (if it is rejected) to any handlers that are attached to that state. This is especially useful in cases where successive blocks of serial computation are required. For example, if the JSON response of one network request is required to perform a second network request, the response from the first request can be passed as the resolved value to the `onResolved` handler. Alternately, a failed network request can pass the HTTP status code to the `onRejected` handler.

Resolved values and rejected reasons are assigned from inside the executor as the first argument to the `resolve()` or `reject()` functions. These values are provided to their respective `onResolved` or `onRejected` handler as the sole parameter. This handoff is demonstrated here:

```
let p1 = new Promise((resolve, reject) => resolve('foo'));
p1.then((value) => console.log(value));    // foo

let p2 = new Promise((resolve, reject) => reject('bar'));
p2.catch((reason) => console.log(reason)); // bar
```

`Promise.resolve()` and `Promise.reject()` accept the value/reason argument when calling the static method. The `onResolved` and `onRejected` handlers are provided the value or reason in the same way as if it were passed from the executor:

```
let p1 = Promise.resolve('foo');
p1.then((value) => console.log(value));    // foo

let p2 = Promise.reject('bar');
p2.catch((reason) => console.log(reason)); // bar
```

Rejecting Promises and Rejection Error Handling

Rejecting a promise is analogous to a `throw` expression in that they both represent a program state that should force a discontinuation of any subsequent operations. Throwing an error inside a promise executor or handler will cause it to reject; the corresponding error object will be the rejection reason. Therefore, these promises all will reject with an error object:

```
let p1 = new Promise((resolve, reject) => reject(Error('foo')));
let p2 = new Promise((resolve, reject) => { throw Error('foo'); });
let p3 = Promise.resolve().then(() => { throw Error('foo'); });
let p4 = Promise.reject(Error('foo'));

setTimeout(console.log, 0, p1); // Promise <rejected>: Error: foo
setTimeout(console.log, 0, p2); // Promise <rejected>: Error: foo
setTimeout(console.log, 0, p3); // Promise <rejected>: Error: foo
setTimeout(console.log, 0, p4); // Promise <rejected>: Error: foo

// Also throws four uncaught errors
```

Promises can be rejected with any value including `undefined`, but it is strongly recommended that you consistently use error object. The primary reason for this is that constructing an error object allows the browser to capture the stack trace inside the error object, which is immensely useful in

debugging. For example, the stack trace for the three errors in the preceding code should appear something like the following:

```
Uncaught (in promise) Error: foo
  at Promise (test.html:5)
  at new Promise (<anonymous>)
  at test.html:5
Uncaught (in promise) Error: foo
  at Promise (test.html:6)
  at new Promise (<anonymous>)
  at test.html:6
Uncaught (in promise) Error: foo
  at test.html:8
Uncaught (in promise) Error: foo
  at Promise.resolve.then (test.html:7)
```

All errors are asynchronously thrown and unhandled, and the stack trace captured by the error objects show the path that the error object took. Also note here the order of errors: The `Promise.resolve().then()` error executes last because it requires an *additional* entry on the runtime's message queue because it is creating one additional promise prior to ultimately throwing the uncaught error.

This example also uncovers an interesting side effect of asynchronous errors. Normally, when throwing an error using the `throw` keyword, the JavaScript runtime's error handling behavior will decline to execute any instructions following the thrown error.

```
throw Error('foo');
console.log('bar'); // This will never print

// Uncaught Error: foo
```

However, when an error is thrown inside a promise, because the error is actually being thrown asynchronously from the message queue, it will not prevent the runtime from continuing to execute synchronous instructions:

```
Promise.reject(Error('foo'));
console.log('bar');
// bar

// Uncaught (in promise) Error: foo
```

As demonstrated earlier in this chapter with `Promise.reject()`, an asynchronous error can be caught only with an asynchronous `onRejection` handler.

```
// Correct
Promise.reject(Error('foo')).catch((e) => {});

// Incorrect
try {
  Promise.reject(Error('foo'));
} catch(e) {}
```

This does not apply to catching the error while still inside the executor, where `try/catch` will still suffice to catch the error before it rejects the promise:

```
let p = new Promise((resolve, reject) => {
  try {
```

```
        throw Error('foo');
    } catch(e) {}

    resolve('bar');
  });

  setTimeout(console.log, 0, p); // Promise <resolved>: bar
```

The `onRejected` handler for `then()` and `catch()` is analogous to the semantics of `try/catch` in that catching an error should effectively neutralize it and allow for normal computation to continue. Therefore, it should make sense that an `onRejected` handler tasked with catching asynchronous error will in fact return a *resolved* promise. The synchronous/synchronous comparison are demonstrated in the following example:

```
console.log('begin synchronous execution');
try {
  throw Error('foo');
} catch(e) {
  console.log('caught error', e);
}
console.log('continue synchronous execution');

// begin synchronous execution
// caught error Error: foo
// continue synchronous execution

new Promise((resolve, reject) => {
  console.log('begin asynchronous execution');
  reject(Error('bar'));
}).catch((e) => {
  console.log('caught error', e);
}).then(() => {
  console.log('continue asynchronous execution');
});

// begin asynchronous execution
// caught error Error: bar
// continue asynchronous execution
```

Promise Chaining and Composition

Combining multiple promises together enables some powerful code patterns. Such behavior is possible in two primary ways: promise chaining, which involves strictly sequencing multiple promises, and promise composition, which involves combining multiple promises into a single promise.

Promise Chaining

One of the more useful aspects of ECMAScript promises is their ability to be strictly sequenced. This is enabled through the Promise API's structure: Each of the promise instance's methods—`then()`, `catch()`, and `finally()`—returns a *separate* promise instance, which in turn can have another

instance method called upon it. Successively invoking methods in such a manner is referred to as “promise chaining.” The following is a trivial example of this:

```
let p = new Promise((resolve, reject) => {
  console.log('first');
  resolve();
});
p.then(() => console.log('second'))
  .then(() => console.log('third'))
  .then(() => console.log('fourth'));

// first
// second
// third
// fourth
```

This implementation is ultimately executing chained *synchronous* tasks. Because of this, the work performed isn’t very useful or interesting because it is approximately the same as successively invoking four functions in sequence:

```
(() => console.log('first'))();
(() => console.log('second'))();
(() => console.log('third'))();
(() => console.log('fourth'))();
```

To chain *asynchronous* tasks, this example can be retooled so that each executor returns a promise instance. Because each successive promise will await the resolution of its predecessor, such a strategy can be used to serialize asynchronous tasks. For example, this can be used to execute multiple promises in series that resolve after a timeout:

```
let p1 = new Promise((resolve, reject) => {
  console.log('p1 executor');
  setTimeout(resolve, 1000);
});

p1.then(() => new Promise((resolve, reject) => {
  console.log('p2 executor');
  setTimeout(resolve, 1000);
}))
  .then(() => new Promise((resolve, reject) => {
    console.log('p3 executor');
    setTimeout(resolve, 1000);
  }))
  .then(() => new Promise((resolve, reject) => {
    console.log('p4 executor');
    setTimeout(resolve, 1000);
  }));

// p1 executor (after 1s)
// p2 executor (after 2s)
// p3 executor (after 3s)
// p4 executor (after 4s)
```

Combining the promise generation into a single factory function yields the following:

```
function delayedResolve(str) {
  return new Promise((resolve, reject) => {
    console.log(str);
    setTimeout(resolve, 1000);
  });
}

delayedResolve('p1 executor')
  .then(() => delayedResolve('p2 executor'))
  .then(() => delayedResolve('p3 executor'))
  .then(() => delayedResolve('p4 executor'))

// p1 executor (after 1s)
// p2 executor (after 2s)
// p3 executor (after 3s)
// p4 executor (after 4s)
```

Each successive handler waits for its predecessor to resolve, instantiates a new promise instance, and returns it. Such a structure is able to neatly serialize asynchronous code without forcing the use of callbacks. Without the use of promises, the preceding code would look something like this:

```
function delayedExecute(str, callback = null) {
  setTimeout(() => {
    console.log(str);
    callback && callback();
  }, 1000)
}

delayedExecute('p1 callback', () => {
  delayedExecute('p2 callback', () => {
    delayedExecute('p3 callback', () => {
      delayedExecute('p4 callback');
    });
  });
});

// p1 callback (after 1s)
// p2 callback (after 2s)
// p3 callback (after 3s)
// p4 callback (after 4s)
```

The observant developer will note that this effectively reintroduces the callback hell that promises are designed to circumvent.

Because `then()`, `catch()`, and `finally()` all return a promise, chaining them together is straightforward. The following example incorporates all three:

```
let p = new Promise((resolve, reject) => {
  console.log('initial promise rejects');
  reject();
});

p.catch(() => console.log('reject handler'))
  .then(() => console.log('resolve handler'))
  .finally(() => console.log('finally handler'));
```



```

// initial promise rejects
// reject handler
// resolve handler
// finally handler

```

Promise Graphs

Because a single promise can have an arbitrary number of handlers attached, forming directed acyclic graphs of chained promises is also possible. Each promise is a node in the graph, and attaching a handler using an instance method adds a directed vertex. Because each node in the graph will wait for its predecessor to settle, you are guaranteed that the direction of graph vertices will indicate the order of promise execution.

The following is an example of one possible type of promise directed graph, a binary tree:

```

//      A
//     / \
//    B  C
//   /\  /\
//  D E F G

let A = new Promise((resolve, reject) => {
  console.log('A');
  resolve();
});

let B = A.then(() => console.log('B'));
let C = A.then(() => console.log('C'));

B.then(() => console.log('D'));
B.then(() => console.log('E'));
C.then(() => console.log('F'));
C.then(() => console.log('G'));

// A
// B
// C
// D
// E
// F
// G

```

Note here that the order of log statements is a level-order traversal of this binary tree. As discussed in an earlier section, a promise's handlers are expected to execute in the order they were attached. Because the handlers of a promise are *eagerly* added to the message queue but *lazily* executed, the result of this behavior is a level-order traversal.

Trees are only one manifestation of a promise graph. Because there is not necessarily a single root promise node, and because multiple promises can be combined into a single promise (using `Promise.all()` or `Promise.race()` as discussed in an upcoming section), a directed acyclic graph is the most accurate characterization of the universe of promise chaining possibilities.

Parallel Promise Composition with Promise.all() and Promise.race()

The `Promise` class provides two static methods that allow you to compose a new promise instance out of several promise instances. The behavior of this composed promise is based on how the promises inside it behave.

Promise.all()

The `Promise.all()` static method creates an all-or-nothing promise that resolves only once every promise in a collection of promises resolves. The static method accepts an iterable and returns a new promise:

```
let p1 = Promise.all([
  Promise.resolve(),
  Promise.resolve()
]);

// Elements in the iterable are coerced into a promise using Promise.resolve()
let p2 = Promise.all([3, 4]);

// Empty iterable is equivalent to Promise.resolve()
let p3 = Promise.all([]);

// Invalid syntax
let p4 = Promise.all();
// TypeError: cannot read Symbol.iterator of undefined
```

The composed promise will only resolve once every contained promise is resolved:

```
let p = Promise.all([
  Promise.resolve(),
  new Promise((resolve, reject) => setTimeout(resolve, 1000))
]);
setTimeout(console.log, 0, p); // Promise <pending>

p.then(() => setTimeout(console.log, 0, 'all() resolved!'));

// all() resolved! (After ~1000ms)
```

If at least one contained promise remains pending, the composed promise also will remain pending. If one contained promise rejects, the composed promise will reject:

```
// Will forever remain pending
let p1 = Promise.all([new Promise(() => {})]);
setTimeout(console.log, 0, p1); // Promise <pending>

// Single rejection causes rejection of composed promise
let p2 = Promise.all([
  Promise.resolve(),
  Promise.reject(),
  Promise.resolve()
]);
setTimeout(console.log, 0, p2); // Promise <rejected>

// Uncaught (in promise) undefined
```

If all promises successfully resolve, the resolved value of the composed promise will be an array of all of the resolved values of the contained promises, in iterator order:

```
let p = Promise.all([
  Promise.resolve(3),
  Promise.resolve(),
  Promise.resolve(4)
]);

p.then((values) => setTimeout(console.log, 0, values)); // [3, undefined, 4]
```

If one of the promises rejects, whichever is the first to reject will set the rejection reason for the composed promise. Subsequent rejections will not affect the rejection reason; however, the normal rejection behavior of those contained promise instances is not affected. Importantly, the composed promise *will* silently handle the rejection of all contained promises, as demonstrated here:

```
// Although only the first rejection reason will be provided in
// the rejection handler, the second rejection will be silently
// handled and no error will escape
let p = Promise.all([
  Promise.reject(3),
  new Promise((resolve, reject) => setTimeout(reject, 1000))
]);

p.catch((reason) => setTimeout(console.log, 0, reason)); // 3

// No unhandled errors
```

Promise.race()

The `Promise.race()` static method creates a promise that will mirror whichever promise inside a collection of promises reaches a resolved or rejected state first. The static method accepts an iterable and returns a new promise:

```
let p1 = Promise.race([
  Promise.resolve(),
  Promise.resolve()
]);

// Elements in the iterable are coerced into a promise using Promise.resolve()
let p2 = Promise.race([3, 4]);

// Empty iterable is equivalent to new Promise(() => {})
let p3 = Promise.race([]);

// Invalid syntax
let p4 = Promise.race();
// TypeError: cannot read Symbol.iterator of undefined
```

The `Promise.race()` method does not give preferential treatment to a resolved or a rejected promise. The composed promise will pass through the status and value/reason of the first settled promise, as shown here:

```
// Resolve occurs first, reject in timeout ignored
let p1 = Promise.race([
```

```
    Promise.resolve(3),
    new Promise((resolve, reject) => setTimeout(reject, 1000))
  ]);
setTimeout(console.log, 0, p1); // Promise <resolved>: 3

// Reject occurs first, resolve in timeout ignored
let p2 = Promise.race([
  Promise.reject(4),
  new Promise((resolve, reject) => setTimeout(resolve, 1000))
]);
setTimeout(console.log, 0, p2); // Promise <rejected>: 4

// Iterator order is the tiebreaker for settling order
let p3 = Promise.race([
  Promise.resolve(5),
  Promise.resolve(6),
  Promise.resolve(7)
]);
setTimeout(console.log, 0, p3); // Promise <resolved>: 5
```

If one of the promises rejects, whichever is the first to reject will set the rejection reason for the composed promise. Subsequent rejections will not affect the rejection reason; however, the normal rejection behavior of those contained promise instances is not affected. As is the case with `Promise.all()`, the composed promise *will* silently handle the rejection of all contained promises, as demonstrated here:

```
// Although only the first rejection reason will be provided in
// the rejection handler, the second rejection will be silently
// handled and no error will escape
let p = Promise.race([
  Promise.reject(3),
  new Promise((resolve, reject) => setTimeout(reject, 1000))
]);

p.catch((reason) => setTimeout(console.log, 0, reason)); // 3

// No unhandled errors
```

Serial Promise Composition

The discussion of promise chaining thus far has focused on serialization of execution and largely ignored a core feature of promises: their ability to asynchronously produce a value and provide it to handlers. Chaining promises together with the intention of each successive promise using the value of its predecessor is a fundamental feature of promises. This is in many ways analogous to *function composition*, where multiple functions are composed together into a new function, demonstrated here:

```
function addTwo(x) {return x + 2;}
function addThree(x) {return x + 3;}
function addFive(x) {return x + 5;}

function addTen(x) {
  return addFive(addTwo(addThree(x)));
}

console.log(addTen(7)); // 17
```

In this example, function composition is used to combine these three functions together to operate on a single value. Similarly, promises can be composed together to progressively consume a value and produce a single promise containing the result. Doing so explicitly would appear as follows:

```
function addTwo(x) {return x + 2;}
function addThree(x) {return x + 3;}
function addFive(x) {return x + 5;}

function addTen(x) {
  return Promise.resolve(x)
    .then(addTwo)
    .then(addThree)
    .then(addFive);
}

addTen(8).then(console.log); // 18
```

This can be fashioned into a more succinct form using `Array.prototype.reduce()`:

```
function addTwo(x) {return x + 2;}
function addThree(x) {return x + 3;}
function addFive(x) {return x + 5;}

function addTen(x) {
  return [addTwo, addThree, addFive]
    .reduce((promise, fn) => promise.then(fn), Promise.resolve(x));
}

addTen(8).then(console.log); // 18
```

Such a strategy for composing promises can be generalized into a function that can compose any number of functions into a value-passing promise chain. This generalized composition function can be implemented as follows:

```
function addTwo(x) {return x + 2;}
function addThree(x) {return x + 3;}
function addFive(x) {return x + 5;}

function compose(...fns) {
  return (x) => fns.reduce((promise, fn) => promise.then(fn), Promise.resolve(x))
}

let addTen = compose(addTwo, addThree, addFive);

addTen(8).then(console.log); // 18
```

NOTE *This concept is revisited in the “Async Functions” section later in the chapter.*

Promise Extensions

The ES6 promise implementation is robust, but as is the case with any piece of software, there will be shortcomings. Two offerings available in some third-party promise implementations but lacking in the formal ECMAScript specification are promise canceling and progress tracking.

Promise Canceling

Often, a promise will be in progress but the program will no longer care about the result. The ability to “cancel” a promise would be useful in such a situation. Some third-party promise libraries such as Bluebird offer such a feature, and even ECMAScript was slated to offer such a feature before it was ultimately withdrawn (<https://github.com/tc39/proposal-cancelable-promises>). As a result, ES6 promises are considered “eager”: Once the promise’s encapsulated function is underway, there is no way to prevent this process from completing.

It is still possible to implement an ad-hoc implementation that is a facsimile of the original design. Such an implementation makes use of a “cancel token,” a concept fleshed out in Kevin Smith’s design sketch (<https://github.com/zenparsing/es-cancel-token>). A generated cancel token provides an interface through which to cancel a promise, as well as a promise hook with which to trigger cancellation behavior and evaluate cancellation state.

A basic implementation of a `CancelToken` class might appear as follows:

```
class CancelToken {
  constructor(cancelFn) {
    this.promise = new Promise((resolve, reject) => {
      cancelFn(resolve);
    });
  }
}
```

This class wraps a promise that exposes the resolve method to a `cancelFn` parameter. An external entity will then be able to provide a function to the constructor, allowing that entity to control exactly when the token should be canceled. This promise is a public member of the token class, and therefore it is possible to add listeners to the cancellation promise.

A rough example of how this class could be used is shown here:

```
<button id="start">Start</button>
<button id="cancel">Cancel</button>

<script>
class CancelToken {
  constructor(cancelFn) {
    this.promise = new Promise((resolve, reject) => {
      cancelFn(() => {
        setTimeout(console.log, 0, "delay cancelled");
        resolve();
      });
    });
  }
}

```

```

const startButton = document.querySelector('#start');
const cancelButton = document.querySelector('#cancel');

function cancellableDelayedResolve(delay) {
  setTimeout(console.log, 0, "set delay");

  return new Promise((resolve, reject) => {
    const id = setTimeout(() => {
      setTimeout(console.log, 0, "delayed resolve");
      resolve();
    }, delay);

    const cancelToken = new CancelToken((cancelCallback) =>
      cancelButton.addEventListener("click", cancelCallback));

    cancelToken.promise.then(() => clearTimeout(id));
  });
}

startButton.addEventListener("click", () => cancellableDelayedResolve(1000));
</script>

```

Each click on the Start button begins a timeout and instantiates a new `CancelToken` instance. The Cancel button is configured so that a click will trigger the token's promise to resolve. Upon resolving, the timeout initially set by the Start button click will be canceled.

Promise Progress Notifications

An in-progress promise might have several discrete “stages” that it will progress through before actually resolving. In some situations, it can be useful to allow a program to watch for a promise to reach these checkpoints. ECMAScript 6 promises do not support this concept, but it is still possible to emulate this behavior by extending a promise.

One potential implementation is to extend the `Promise` class with a `notify()` method, as shown here:

```

class TrackablePromise extends Promise {
  constructor(executor) {
    const notifyHandlers = [];

    super((resolve, reject) => {
      return executor(resolve, reject, (status) => {
        notifyHandlers.map((handler) => handler(status));
      });
    });

    this.notifyHandlers = notifyHandlers;
  }

  notify(notifyHandler) {
    this.notifyHandlers.push(notifyHandler);
    return this;
  }
}

```

A `TrackablePromise` would then be able to use the `notify()` function inside the executor. A promise instantiation could use this function as follows:

```
let p = new TrackablePromise((resolve, reject, notify) => {
  function countdown(x) {
    if (x > 0) {
      notify(`${20 * x}% remaining`);
      setTimeout(() => countdown(x - 1), 1000);
    } else {
      resolve();
    }
  }

  countdown(5);
});
```

This promise will recursively set a 1000ms timeout five consecutive times before resolving. Each timeout handler will invoke `notify()` and pass a status. Providing a notification handler could be done as follows:

```
...

let p = new TrackablePromise((resolve, reject, notify) => {
  function countdown(x) {
    if (x > 0) {
      notify(`${20 * x}% remaining`);
      setTimeout(() => countdown(x - 1), 1000);
    } else {
      resolve();
    }
  }

  countdown(5);
});

p.notify(x) => setTimeout(console.log, 0, 'progress:', x);

p.then(() => setTimeout(console.log, 0, 'completed'));

// (after 1s) 80% remaining
// (after 2s) 60% remaining
// (after 3s) 40% remaining
// (after 4s) 20% remaining
// (after 5s) completed
```

This `notify()` method is designed to be chainable by returning itself, and handler execution will be preserved on a per-notification basis, as shown here:

```
...

p.notify(x) => setTimeout(console.log, 0, 'a:', x)
  .notify(x) => setTimeout(console.log, 0, 'b:', x);

p.then(() => setTimeout(console.log, 0, 'completed'));

// (after 1s) a: 80% remaining
// (after 1s) b: 80% remaining
```



```
// (after 2s) a: 60% remaining
// (after 2s) b: 60% remaining
// (after 3s) a: 40% remaining
// (after 3s) b: 40% remaining
// (after 4s) a: 20% remaining
// (after 4s) b: 20% remaining
// (after 5s) completed
```

Overall, this is a relatively crude implementation, but it should demonstrate how such a notification feature could be useful.

NOTE *One of the primary reasons that ES6 promises do not feature cancellation or notification features is that it greatly complicates promise chaining and composition. It isn't entirely clear what is expected to happen in scenarios where cancellations or notifications occur in promises with other promise dependencies, such as in a promise chain. Rhetorically speaking, what is sensible behavior when a promise inside `Promise.all()` cancels, or when a notification is sent from a preceding promise inside a promise chain?*

ASYNC FUNCTIONS

Async functions, also referred to by the operative keyword pair “async/await,” are the application of the ES6 Promise paradigm to ECMAScript functions. Support for async/await was introduced in the ES7 specification. It is both a behavioral and syntactical enhancement to the specification that allows for JavaScript code which is written in a synchronous fashion, but actually is able to behave asynchronously. The simplest example of this begins with a simple promise, which resolves with a value after a timeout:

```
let p = new Promise((resolve, reject) => setTimeout(resolve, 1000, 3));
```

This promise will resolve with a value of 3 after 1000ms. For other parts of the program to access this value once it is ready, it will need to exist inside a resolved handler:

```
let p = new Promise((resolve, reject) => setTimeout(resolve, 1000, 3));

p.then((x) => console.log(x)); // 3
```

This is fairly inconvenient, as the rest of the program now needs to be shoehorned into the promise handler. It is possible to move the handler into a function definition:

```
function handler(x) { console.log(x); }

let p = new Promise((resolve, reject) => setTimeout(resolve, 1000, 3));

p.then(handler); // 3
```

This isn't much of an improvement. The fact remains that any subsequent code that wishes to access the value produced by the promise needs to be fed that value through a handler, which means being shoved into a handler function. The ES7 offers async/await as an elegant solution to this problem.

Async Function Basics

ES7's `async/await` is intended to directly address the issue of organizing code which makes use of asynchronous constructs. It introduces a logical extension of asynchronous behavior into the domain of JavaScript functions by introducing two new keywords, `async` and `await`.

The `async` keyword

An `async` function can be declared by prepending the `async` keyword. This keyword can be used on function declarations, function expressions, arrow functions, and methods:

```
async function foo() {}

let bar = async function() {};

let baz = async () => {};

class Qux {
  async qux() {}
}
```

Using the `async` keyword will create a function that exhibits some asynchronous characteristics but overall is still synchronously evaluated. In all other respects such as arguments and closures, it still exhibits all the normal behavior of a JavaScript function. Consider this simple demonstration here, which shows the `foo()` function is still evaluated before proceeding to subsequent instructions:

```
async function foo() {
  console.log(1);
}

foo();
console.log(2);

// 1
// 2
```

In an `async` function, whatever value is returned with the `return` keyword (or `undefined` if there is no `return`) will be effectively converted into a promise object with `Promise.resolve()`. An `async` function will always return a promise object. Outside the function, the evaluated function will be this promise object:

```
async function foo() {
  console.log(1);
  return 3;
}

// Attach a resolved handler to the returned promise
foo().then(console.log);

console.log(2);

// 1
// 2
// 3
```

Of course, this means returning a promise object affords identical behavior:

```

async function foo() {
  console.log(1);
  return Promise.resolve(3);
}

// Attach a resolved handler to the returned promise
foo().then(console.log);

console.log(2);

// 1
// 2
// 3

```

The return value of an async function anticipates, but does not actually require, a thenable object: It will also work with regular values. A thenable object will be “unwrapped” via the first argument provided to the `then()` callback. A non-thenable object will be passed through as if it were an already resolved promise. These various scenarios are demonstrated here:

```

// Return a primitive
async function foo() {
  return 'foo';
}
foo().then(console.log);
// foo

// Return a non-thenable object
async function bar() {
  return ['bar'];
}
bar().then(console.log);
// ['bar']

// Return a thenable non-promise object
async function baz() {
  const thenable = {
    then(callback) { callback('baz'); }
  };
  return thenable;
}
baz().then(console.log);
// baz

// Return a promise
async function qux() {
  return Promise.resolve('qux');
}
qux().then(console.log);
// qux

```

As with promise handler functions, throwing an error value will instead return a rejected promise:

```

async function foo() {
  console.log(1);
}

```

```

    throw 3;
  }

  // Attach a rejected handler to the returned promise
  foo().catch(console.log);
  console.log(2);

  // 1
  // 2
  // 3

```

However, promise rejection errors will *not* be captured by the `async` function:

```

async function foo() {
  console.log(1);
  Promise.reject(3);
}

// Attach a rejected handler to the returned promise
foo().catch(console.log);
console.log(2);

// 1
// 2
// Uncaught (in promise): 3

```

The `await` keyword

Because an `async` function indicates to code invoking it that there is no expectation of timely completion, the logical extension of this behavior is the ability to pause and resume execution. This exact feature is possible using the `await` keyword, which is used to pause execution while waiting for a promise to resolve. Consider the example from the beginning of the chapter, shown here:

```

let p = new Promise((resolve, reject) => setTimeout(resolve, 1000, 3));

p.then((x) => console.log(x)); // 3

```

This can be rewritten using `async/await` as follows:

```

async function foo() {
  let p = new Promise((resolve, reject) => setTimeout(resolve, 1000, 3));
  console.log(await p);
}

foo();
// 3

```

The `await` keyword will pause execution of the `async` function, releasing the JavaScript runtime's thread of execution. This behavior is not unlike that of the `yield` keyword in a generator function. The `await` keyword will attempt to “unwrap” the object's value, pass the value through to the expression, and asynchronously resume execution of the `async` function.

The `await` keyword is used in the same way as a JavaScript unary operator. It can be used standalone or inside an expression, as shown in the following examples:

```

// Asynchronously print "foo"
async function foo() {

```

```

    console.log(await Promise.resolve('foo'));
  }
  foo();
  // foo

  // Asynchronously print "bar"
  async function bar() {
    return await Promise.resolve('bar');
  }
  bar().then(console.log);
  // bar

  // Asynchronously print "baz" after 1000ms
  async function baz() {
    await new Promise((resolve, reject) => setTimeout(resolve, 1000));
    console.log('baz');
  }
  baz();
  // baz <after 1000ms>

```

The `await` keyword anticipates, but does not actually require, a thenable object: It will also work with regular values. A thenable object will be “unwrapped” via the first argument provided to the `then()` callback. A non-thenable object will be passed through as if it were an already resolved promise. These various scenarios are demonstrated here:

```

// Await a primitive
async function foo() {
  console.log(await 'foo');
}
foo();
// foo

// Await a non-thenable object
async function bar() {
  console.log(await ['bar']);
}
bar();
// ['bar']

// Await a thenable non-promise object
async function baz() {
  const thenable = {
    then(callback) { callback('baz'); }
  };
  console.log(await thenable);
}
baz();
// baz

// Await a promise
async function qux() {
  console.log(await Promise.resolve('qux'));
}
qux();
// qux

```

Awaiting a synchronous operation that throws an error will instead return a rejected promise:

```
async function foo() {
  console.log(1);
  await (() => { throw 3; })();
}

// Attach a rejected handler to the returned promise
foo().catch(console.log);
console.log(2);

// 1
// 2
// 3
```

As shown earlier, a standalone `Promise.reject()` will not be captured by an async function and will throw as an unhandled error. However, using `await` on a promise that rejects will unwrap the error value:

```
async function foo() {
  console.log(1);
  await Promise.reject(3);
  console.log(4); // never prints
}

// Attach a rejected handler to the returned promise
foo().catch(console.log);
console.log(2);

// 1
// 2
// 3
```

Restrictions on await

The `await` keyword must be used inside an async function; it cannot be used in a top-level context such as a script tag or module. However, there is nothing preventing you from immediately invoking an async function. The following two code snippets are effectively identical:

```
async function foo() {
  console.log(await Promise.resolve(3));
}
foo();
// 3

// Immediately invoked async function expression
(async function() {
  console.log(await Promise.resolve(3));
})();
// 3
```

Furthermore, the async nature of a function does not extend to nested functions. Therefore, the `await` keyword can also only appear directly inside an async function definition; attempting to use `await` inside a synchronous function will throw a `SyntaxError`.

Shown below are a few disallowed examples:

```
// Not allowed: 'await' inside arrow function
function foo() {
  const syncFn = () => {
    return await Promise.resolve('foo');
  };
  console.log(syncFn());
}

// Not allowed: 'await' inside function declaration
function bar() {
  function syncFn() {
    return await Promise.resolve('bar');
  }
  console.log(syncFn());
}

// Not allowed: 'await' inside function expression
function baz() {
  const syncFn = function() {
    return await Promise.resolve('baz');
  };
  console.log(syncFn());
}

// Not allowed: IIFE using function expression or arrow function
function qux() {
  (function () { console.log(await Promise.resolve('qux')); })();
  ((() => console.log(await Promise.resolve('qux'))())());
}

```

Halting and Resuming Execution

The true nature of using the `await` keyword is more nuanced than it might initially appear. For example, consider the following example where three functions are invoked in order but their outputs print in reverse:

```
async function foo() {
  console.log(await Promise.resolve('foo'));
}

async function bar() {
  console.log(await 'bar');
}

async function baz() {
  console.log('baz');
}

foo();
bar();
baz();

// baz
// bar
// foo

```

In the paradigm of `async/await`, the `await` keyword is doing all the heavy lifting; the `async` keyword is, in many ways, just a special indicator to the JavaScript interpreter. After all, an `async` function that doesn't contain the `await` keyword executes much like a regular function:

```
async function foo() {
  console.log(2);
}

console.log(1);
foo();
console.log(3);

// 1
// 2
// 3
```

The key to fully understanding the `await` keyword is that it doesn't just wait for a value to become available. When the `await` keyword is encountered, the JavaScript runtime can track exactly where the execution was paused. When the value to the right of `await` is ready, the JavaScript runtime will push a task on the message queue that will asynchronously resume execution of that function.

Therefore, even when `await` is paired with an immediately available value, the rest of the function will still be *asynchronously* evaluated. This is demonstrated in the following example:

```
async function foo() {
  console.log(2);
  await null;
  console.log(4);
}

console.log(1);
foo();
console.log(3);

// 1
// 2
// 3
// 4
```

The order of the console readout is best explained in terms of how the runtime handles this example:

1. **Print 1.**
2. Invoke `async` function `foo`.
3. (inside `foo`) **Print 2.**
4. (inside `foo`) `await` keyword pauses execution and adds task on message queue for immediately available value of `null`.
5. `foo` exits.
6. **Print 3.**
7. Synchronous thread of execution finishes.
8. JavaScript runtime dequeues task off message queue to resume execution.

9. (inside `foo`) Execution resumes; `await` is provided with the value `null` (which, here, goes unused).
10. (inside `foo`) **Print 4.**
11. `foo` returns.

Using `await` with a promise makes this scenario more complicated. In this case, there will, in fact, be two separate message queue tasks that are evaluated asynchronously to complete execution of the `async` function. The following example, which might seem completely counterintuitive, demonstrates the order of execution:

```
async function foo() {
  console.log(2);
  console.log(await Promise.resolve(8));
  console.log(9);
}

async function bar() {
  console.log(4);
  console.log(await 6);
  console.log(7);
}

console.log(1);
foo();
console.log(3);
bar();
console.log(5);

// 1
// 2
// 3
// 4
// 5
// 6
// 7
// 8
// 9
```

The runtime will execute this example as follows:

1. **Print 1.**
2. Invoke `async` function `foo`.
3. (inside `foo`) **Print 2.**
4. (inside `foo`) `await` keyword pauses execution and schedules task to be added to message queue when the promise settles.
5. Promise is immediately resolved; task to provide resolved value to `await` is added to message queue.
6. `foo` exits.

7. **Print 3.**
8. Invoke async function `bar`.
9. (inside `bar`) **Print 4.**
10. (inside `bar`) `await` keyword pauses execution and adds task on message queue for immediately available value of 6.
11. `bar` exits.
12. **Print 5.**
13. Top-level thread of execution finishes.
14. JavaScript runtime dequeues resolved `await` promise handler and provides it with the resolved value of 8.
15. JavaScript runtime enqueues task to resume execution of `foo` onto message queue.
16. JavaScript runtime dequeues task to resume execution of `bar` with value 6 off message queue.
17. (inside `bar`) Execution resumes, `await` is provided with the value 6.
18. (inside `bar`) **Print 6.**
19. (inside `bar`) **Print 7.**
20. `bar` returns.
21. Asynchronous task completes, JavaScript dequeues task to resume execution of `foo` with value 8.
22. (inside `foo`) **Print 8.**
23. (inside `foo`) **Print 9.**
24. `foo` returns.

Strategies for Async Functions

Because of their convenience and utility, async functions are increasingly a ubiquitous pillar of JavaScript codebases. Even so, when wielding async functions, keep certain considerations in mind.

Implementing `Sleep()`

When learning JavaScript for the first time, many developers will reach for a construct similar to Java's `Thread.sleep()` in an attempt to introduce a non-blocking delay into their program. Formerly, this was a cornerstone pedagogical moment for introducing how `setTimeout` fit into the JavaScript runtime's behavior.

With async functions, this is no longer the case! It is trivial to build a utility that allows a function to `sleep()` for a variable number of milliseconds:

```
async function sleep(delay) {  
  return new Promise((resolve) => setTimeout(resolve, delay));  
}
```

```

async function foo() {
  const t0 = Date.now();
  await sleep(1500); // sleep for ~1500ms
  console.log(Date.now() - t0);
}
foo();
// 1502

```

Maximizing Parallelization

If the `await` keyword is not used carefully, your program may be missing out on possible parallelization speedups. Consider the following example, which awaits five random timeouts sequentially:

```

async function randomDelay(id) {
  // Delay between 0 and 1000 ms
  const delay = Math.random() * 1000;
  return new Promise((resolve) => setTimeout(() => {
    console.log(`${id} finished`);
    resolve();
  }, delay));
}

async function foo() {
  const t0 = Date.now();
  await randomDelay(0);
  await randomDelay(1);
  await randomDelay(2);
  await randomDelay(3);
  await randomDelay(4);
  console.log(`${Date.now() - t0}ms elapsed`);
}
foo();

// 0 finished
// 1 finished
// 2 finished
// 3 finished
// 4 finished
// 2219ms elapsed

```

Rolling up into a `for` loop yields the following:

```

async function randomDelay(id) {
  // Delay between 0 and 1000 ms
  const delay = Math.random() * 1000;
  return new Promise((resolve) => setTimeout(() => {
    console.log(`${id} finished`);
    resolve();
  }, delay));
}

async function foo() {
  const t0 = Date.now();
  for (let i = 0; i < 5; ++i) {
    await randomDelay(i);
  }
}

```

```
    console.log(`${Date.now() - t0}ms elapsed`);
  }
  foo();

  // 0 finished
  // 1 finished
  // 2 finished
  // 3 finished
  // 4 finished
  // 2219ms elapsed
```

Even though there is no interdependence between the promises, this async function will pause and wait for each to complete before beginning the next. Doing so guarantees in-order execution, but at the expense of total execution time.

If in-order execution is not required, it is better to initialize the promises all at once and await the results as they become available. This can be done as follows:

```
async function randomDelay(id) {
  // Delay between 0 and 1000 ms
  const delay = Math.random() * 1000;
  return new Promise((resolve) => setTimeout(() => {
    setTimeout(console.log, 0, `${id} finished`);
    resolve();
  }, delay));
}

async function foo() {
  const t0 = Date.now();

  const p0 = randomDelay(0);
  const p1 = randomDelay(1);
  const p2 = randomDelay(2);
  const p3 = randomDelay(3);
  const p4 = randomDelay(4);

  await p0;
  await p1;
  await p2;
  await p3;
  await p4;

  setTimeout(console.log, 0, `${Date.now() - t0}ms elapsed`);
}
foo();

// 1 finished
// 4 finished
// 3 finished
// 0 finished
// 2 finished
// 2219ms elapsed
```

Rolling up into an array and for loop yields the following:

```

async function randomDelay(id) {
  // Delay between 0 and 1000 ms
  const delay = Math.random() * 1000;
  return new Promise((resolve) => setTimeout(() => {
    console.log(`${id} finished`);
    resolve();
  }, delay));
}

async function foo() {
  const t0 = Date.now();

  const promises = Array(5).fill(null).map((_, i) => randomDelay(i));

  for (const p of promises) {
    await p;
  }

  console.log(`${Date.now() - t0}ms elapsed`);
}

foo();

// 4 finished
// 2 finished
// 1 finished
// 0 finished
// 3 finished
// 877ms elapsed

```

Note that, although the execution of the promises is out of order, the `await` statements are provided to the resolved values *in* order:

```

async function randomDelay(id) {
  // Delay between 0 and 1000 ms
  const delay = Math.random() * 1000;
  return new Promise((resolve) => setTimeout(() => {
    console.log(`${id} finished`);
    resolve(id);
  }, delay));
}

async function foo() {
  const t0 = Date.now();

  const promises = Array(5).fill(null).map((_, i) => randomDelay(i));

  for (const p of promises) {
    console.log(`awaited ${await p}`);
  }

  console.log(`${Date.now() - t0}ms elapsed`);
}

foo();

```

```
// 1 finished
// 2 finished
// 4 finished
// 3 finished
// 0 finished
// awaited 0
// awaited 1
// awaited 2
// awaited 3
// awaited 4
// 645ms elapsed
```

Serial Promise Execution

In the “Promises” section of this chapter, there is a discussion on how to compose promises that serially execute and pass values to the subsequent promise. With `async/await`, chaining promises becomes trivial:

```
function addTwo(x) {return x + 2;}
function addThree(x) {return x + 3;}
function addFive(x) {return x + 5;}

async function addTen(x) {
  for (const fn of [addTwo, addThree, addFive]) {
    x = await fn(x);
  }
  return x;
}

addTen(9).then(console.log); // 19
```

Here, `await` is directly passed the return value of each function and the result is iteratively derived. The preceding example does not actually deal in promises, but it can be reconfigured to use `async` functions—and therefore promises—instead:

```
async function addTwo(x) {return x + 2;}
async function addThree(x) {return x + 3;}
async function addFive(x) {return x + 5;}

async function addTen(x) {
  for (const fn of [addTwo, addThree, addFive]) {
    x = await fn(x);
  }
  return x;
}

addTen(9).then(console.log); // 19
```

Stack Traces and Memory Management

Promises and `async` functions have a considerable degree of overlap in terms of functionality they provide, but they diverge considerably when it comes to how they are represented in memory. Consider the following example, which shows the stack trace readout for a rejected promise:

```
function fooPromiseExecutor(resolve, reject) {
  setTimeout(reject, 1000, 'bar');
}
```

```
function foo() {
  new Promise(fooPromiseExecutor);
}

foo();
// Uncaught (in promise) bar
//   setTimeout
//   setTimeout (async)
//   fooPromiseExecutor
//   foo
```

Based on your understanding of promises, this stack trace readout should puzzle you a bit. The stack trace should, quite literally, represent the nested nature of function calls that exists currently in the JavaScript engine's memory stack. When the timeout handler executes and rejects the promise, the error readout shown identifies the nested functions that were invoked to create the promise instance originally. However, it is known that these functions have *already returned* and therefore wouldn't be found in a stack trace.

The answer is simply that the JavaScript engine does extra work to preserve the call stack while it can when creating the promise structure. When an error is thrown, this call stack is retrievable by the runtime's error handling logic and therefore is available in the stack trace. This, of course, means it must preserve the stack trace in memory, which comes at a computational and storage cost.

Consider the previous example if it were reworked with async functions, as demonstrated here:

```
function fooPromiseExecutor(resolve, reject) {
  setTimeout(reject, 1000, 'bar');
}

async function foo() {
  await new Promise(fooPromiseExecutor);
}

foo();

// Uncaught (in promise) bar
//   foo
//   async function (async)
//   foo
```

With this structure, the stack trace is accurately representing the current call stack because `fooPromiseExecutor` has returned and is no longer on the stack, but `foo` is suspended and has not yet exited. The JavaScript runtime can merely store a pointer from a nested function to its container function, as it would with a synchronous function call stack. This pointer is efficiently stored in memory and can be used to generate the stack trace in the event of an error. Such a strategy does not incur extra overhead as is the case with the previous example, and therefore should be preferred if performance is critical to your application.

SUMMARY

Mastering asynchronous behavior inside the single-threaded JavaScript runtime has long been an imposing task. With the introduction of promises in ES6 and `async/await` ES7, asynchronous constructs in ECMAScript have been greatly enhanced. Not only do promises and `async/await` enable

patterns that were previously difficult or impossible to implement, but they engender an entirely new way of writing JavaScript that is cleaner, shorter, and easier to understand and debug.

Promises are built to offer a clean abstraction around asynchronous code. They can represent an asynchronously executed block of code, but they can also represent an asynchronously calculated value. They are especially useful in a situation where the need to serialize asynchronous code blocks arises. Promises are a delightfully malleable construct: They can be serialized, chained, composed, extended, and recombined.

Async functions are the result of applying the promise paradigm to JavaScript functions. They introduce the ability to suspend execution of a function without blocking the main thread of execution. They are tremendously useful both in writing readable promise-centric code as well as in managing serialization and parallelization of asynchronous code. They are one of the most important tools in the modern JavaScript toolkit.

12

The Browser Object Model

WHAT'S IN THIS CHAPTER?

- Understanding the window object, the core of the BOM
- Controlling windows and pop-ups
- Page information from the location object
- Using the navigator object to learn about the browser
- Manipulating the browser history stack with the history object

WROX.COM DOWNLOADS FOR THIS CHAPTER

Please note that all the code examples for this chapter are available as a part of this chapter's code download on the book's website at www.wrox.com/go/projavascript4e on the Download Code tab.

Though ECMAScript describes it as the core of JavaScript, the Browser Object Model (BOM) is really the core of using JavaScript on the web. The BOM provides objects that expose browser functionality independent of any web page content. For years, a lack of any real specification made the BOM both interesting and problematic because browser vendors were free to augment it as they saw fit. The commonalities between browsers became de facto standards that have survived browser development mostly for the purpose of interoperability. Part of the HTML5 specification now covers the major aspects of the BOM, as the W3C seeks to standardize one of the most fundamental parts of JavaScript in the browser.

THE WINDOW OBJECT

At the core of the BOM is the `window` object, which represents an instance of the browser. The `window` object serves a dual purpose in browsers, acting as the JavaScript interface to the browser window and the ECMAScript `Global` object. This means that every object, variable, and function defined in a web page uses `window` as its `Global` object and has access to methods like `parseInt()`.

NOTE *Because `window` object properties are available in the global scope, many browser APIs and associated constructors use a `window` object property as an access point. These APIs are covered elsewhere in the book, predominantly in the JavaScript APIs chapter.*

Furthermore, some of the `window` object's properties will drastically diverge between browsers due to differing vendor implementations. This chapter will not cover deprecated, non-standardized, or vendor-specific `window` properties.

The Global Scope

Because the `window` object doubles as the ECMAScript `Global` object, all variables and functions declared globally with `var` become properties and methods of the `window` object. Consider this example:

```
var age = 29;
var sayAge = () => alert(this.age);

alert(window.age); // 29
sayAge();          // 29
window.sayAge();  // 29
```

Here, a variable named `age` and a function named `sayAge()` are defined in the global scope, which automatically places them on the `window` object. Thus, the variable `age` is also accessible as `window.age`, and the function `sayAge()` is also accessible via `window.sayAge()`. Because `sayAge()` exists in the global scope, `this.age` maps to `window.age`, and the correct result is displayed.

If, instead, `let` or `const` is substituted for `var`, the default attachment to the global object does not occur:

```
let age = 29;
const sayAge = () => alert(this.age);

alert(window.age); // undefined
sayAge();          // undefined
window.sayAge();  // TypeError: window.sayAge is not a function
```

Another thing to keep in mind: attempting to access an undeclared variable throws an error, but it is possible to check for the existence of a potentially undeclared variable by looking on the `window` object. For example:

```
// this throws an error because oldValue is undeclared
var newValue = oldValue;
```

```
// this doesn't throw an error, because it's a property lookup
// newValue is set to undefined
var newValue = window.oldValue;
```

Keeping this in mind, there are many objects in JavaScript that are considered to be global, such as `location` and `navigator` (both discussed later in the chapter), but are actually properties of the `window` object.

Window Relationships

The `top` object always points to the very top (outermost) window, which is the browser window itself. Another window object is called `parent`. The `parent` object always points to the current window's immediate parent window. For the topmost browser window, `parent` is equal to `top` (and both are equal to `window`). The topmost window will never have a value set for `name` unless the window was opened using `window.open()`, as discussed later in this chapter.

There is one final window property, called `self`, which always points to `window`. The two can, in fact, be used interchangeably. Even though it has no separate value, `self` is included for consistency with the `top` and `parent` objects.

Each of these objects is a property of the `window` object, accessible via `window.parent`, `window.top`, and so on. This means it's possible to chain window objects together, such as `window.parent.parent`.

Window Position and Pixel Ratio

The position of a window object may be determined and changed using various properties and methods. Modern browsers all provide `screenLeft` and `screenTop` properties that indicate the window's location in relation to the left and top of the screen, respectively, in CSS pixels.

It is also possible to move the window to a new position using the `moveTo()` and `moveBy()` methods. Each method accepts two arguments. `moveTo()` expects the `x` and `y` coordinates to move to an absolute coordinate, and `moveBy()` expects the number of pixels to move relative to the current coordinate. These methods are demonstrated here:

```
// move the window to the upper-left coordinate
window.moveTo(0,0);

// move the window down by 100 pixels
window.moveBy(0, 100);

// move the window to position (200, 300)
window.moveTo(200, 300);

// move the window left by 50 pixels
window.moveBy(-50, 0);
```

Depending on the browser, these methods may be conditionally or completely disabled.

Pixel Ratios

A "CSS pixel" is the denomination of the pixel used universally in web development. It is defined as an angular measurement: 0.0213° , approximately $1/96$ of an inch on a device held at arm's length. The purpose of this definition is to give the pixel size a uniform meaning across devices: for example,

12px font (measured in CSS pixels) on a low-resolution tablet should appear to be the same size as a 12px (measured in CSS pixels) font on a high-resolution 4k monitor. Therein lies a problem: such a system requires an inherent scaling factor required to convert from physical pixels (the actual resolution of the display) to CSS pixels (the virtual resolution reported to the web browser).

For example, a phone screen might have a *physical* resolution of 1920x1080, but because these pixels are incredibly small the web browser will scale this resolution down to a smaller *logical* resolution, such as 640x360. This scaling factor is provided to the browser as `window.devicePixelRatio`. For a device converting from 1920x1080 to 640x360, the `devicePixelRatio` would be reported as 3. In this way, a 12px font in *physical* pixels would really be a 36px font in *logical* pixels (or CSS pixels).

This `devicePixelRatio` is effectively an analogue of DPI (dots per inch). DPI is effectively recording the same information, but `devicePixelRatio` offers it as a unitless ratio.

Window Size

Determining the size of a window cross-browser is not straightforward. All modern browsers provide four properties: `innerWidth`, `innerHeight`, `outerWidth`, and `outerHeight`. `outerWidth` and `outerHeight` return the dimensions of the browser window itself (regardless of whether it's used on the topmost window object or on a frame). The `innerWidth` and `innerHeight` properties indicate the size of the page viewport inside the browser window (minus borders and toolbars).

The `document.documentElement.clientWidth` and `document.documentElement.clientHeight` properties provide the width and height of the page viewport.

The end result is that there's no accurate way to determine the size of the browser window itself, but it is possible to get the dimensions of the page viewport, as shown in the following example:

```
let pageWidth = window.innerWidth,
    pageHeight = window.innerHeight;

if (typeof pageWidth !== "number") {
  if (document.compatMode === "CSS1Compat") {
    pageWidth = document.documentElement.clientWidth;
    pageHeight = document.documentElement.clientHeight;
  } else {
    pageWidth = document.body.clientWidth;
    pageHeight = document.body.clientHeight;
  }
}
```

In this code, `pageWidth` and `pageHeight` are assigned initial values of `window.innerWidth` and `window.innerHeight`, respectively. A check is then done to see if the value of `pageWidth` is a number; if not, then the code determines if the page is in standards mode by using `document.compatMode`. If it is, then `document.documentElement.clientWidth` and `document.documentElement.clientHeight` are used; otherwise, `document.body.clientWidth` and `document.body.clientHeight` are used.

For mobile devices, `window.innerWidth` and `window.innerHeight` are the dimensions of the visual viewport, which is the visible area of the page on the screen. Mobile Internet Explorer doesn't support these properties but provides the same information on `document.documentElement.clientWidth` and `document.documentElement.clientHeight`. These values change as you zoom in or out of a page.

In other mobile browsers, the measurements of `document.documentElement` provide measurements for the layout viewport, which are the actual dimensions of the rendered page (as opposed to the visual viewport, which is only a small portion of the entire page). Mobile Internet Explorer stores this information in `document.body.clientWidth` and `document.body.clientHeight`. These values do not change as you zoom in and out.

Because of these differences from desktop browsers, you may need to first determine if the user is on a mobile device before deciding which measurements to use and honor.

NOTE *The topic of mobile viewports is a complex one with various exceptions and caveats. Peter-Paul Koch, a mobile development consultant, outlined all of his research at <http://quirksmode.org/mobile/viewports2.html>. This is recommended reading if you're developing for mobile devices.*

The browser window can be resized using the `resizeTo()` and `resizeBy()` methods. Each method accepts two arguments: `resizeTo()` expects a new width and height, and `resizeBy()` expects the differences in each dimension. Here's an example:

```
// resize to 100 x 100
window.resizeTo(100, 100);

// resize to 200 x 150
window.resizeBy(100, 50);

// resize to 300 x 300
window.resizeTo(300, 300);
```

As with the window-movement methods, the resize methods may be disabled by the browser and are disabled by default in some browsers. Also like the movement methods, these methods apply only to the topmost window object.

Window Viewport Position

Because the browser window is usually not large enough to display the entire rendered document at once, the user is given the ability to scroll around the document with a limited viewport. The CSS pixel offset of the current viewport is available as an X and Y pair, representing the number of pixels the viewport is currently scrolled in that direction. The X and Y offsets are each accessible via two properties, which return identical values: `window.pageXOffset` / `window.scrollX`, and `window.pageYOffset` / `window.scrollY`.

It is also possible to explicitly scroll the page by a certain amount using several different window methods. These methods are passed two coordinates indicating how far in the X and Y direction the viewport should scroll. `window.scroll(x, y)` will scroll the viewport by a relative amount. (`window.scrollBy(x, y)` behaves identically). `window.scrollTo(x, y)` scrolls the viewport to an absolute offset.

```
// Scroll down 100px relative to the current viewport
window.scroll(0, 100);
```

```
// Scroll right 40px relative to the current viewport
Window.scroll(40, 0);

// Scroll to the top left corner of the page
// window.scrollTo(0, 0);

// Scroll to 100px from the top and left of the page
// window.scrollTo(100, 100);
```

These methods also accept a `ScrollToOptions` dictionary, which in addition to holding the offset values can instruct the browser to smooth the scroll via the `behavior` property.

```
// normal scroll
window.scrollTo({
  left: 100,
  top: 100,
  behavior: 'auto'
});

// smooth scroll
window.scrollTo({
  left: 100,
  top: 100,
  behavior: 'smooth'
});
```

Navigating and Opening Windows

The `window.open()` method can be used both to navigate to a particular URL and to open a new browser window. This method accepts four arguments: the URL to load, the window target, a string of features, and a Boolean value indicating that the new page should take the place of the currently loaded page in the browser history. Typically only the first three arguments are used; the last argument applies only when not opening a new window.

If the second argument passed to `window.open()` is the name of a window or frame that already exists, then the URL is loaded into the window or frame with that name. Here's an example:

```
// same as <a href="http://www.wrox.com" target="topFrame"/>
window.open("http://www.wrox.com/", "topFrame");
```

This line of code acts as if the user clicked a link with the `href` attribute set to `"http://www.wrox.com"` and the `target` attribute set to `"topFrame"`. If there is a window named `"topFrame"`, then the URL will be loaded there; otherwise, a new window is created and given the name `"topFrame"`. The second argument may also be any of the special window names: `_self`, `_parent`, `_top`, or `_blank`.

Popping Up Windows

When the second argument doesn't identify an existing window, a new window or tab is created based on a string passed in as the third argument. If the third argument is missing, a new browser window (or tab, based on browser settings) is opened with all of the default browser window settings. (Toolbars, the location bar, and the status bar are all set based on the browser's default settings.) The third argument is ignored when not opening a new window.

The third argument is a comma-delimited string of settings indicating display information for the new window. The following table describes the various options.

SETTING	VALUE(S)	DESCRIPTION
fullscreen	"yes" or "no"	Indicates that the browser window should be maximized when created. Internet Explorer only.
height	Number	The initial height of the new window. This cannot be less than 100.
left	Number	The initial left coordinate of the new window. This cannot be a negative number.
location	"yes" or "no"	Indicates if the location bar should be displayed. The default varies based on the browser. When set to "no", the location bar may be either hidden or disabled (browser-dependent).
menubar	"yes" or "no"	Indicates if the menu bar should be displayed. The default is "no".
resizable	"yes" or "no"	Indicates if the new window can be resized by dragging its border. The default is "no".
scrollbars	"yes" or "no"	Indicates if the new window allows scrolling if the content cannot fit in the viewport. The default is "no".
status	"yes" or "no"	Indicates if the status bar should be displayed. The default varies based on the browser.
toolbar	"yes" or "no"	Indicates if the toolbar should be displayed. The default is "no".
top	Number	The initial top coordinate of the new window. This cannot be a negative number.
width	Number	The initial width of the new window. This cannot be less than 100.

Any or all of these settings may be specified as a comma-delimited set of name-value pairs. The name-value pairs are indicated by an equal sign. (No white space is allowed in the feature string.) Consider the following example:

```

window.open("http://www.wrox.com/",
            "wroxWindow",
            "height=400,width=400,top=10,left=10,resizable=yes");

```

This code opens a new resizable window that's 400x400 and positioned 10 pixels from the top and left of the screen.

The `window.open()` method returns a reference to the newly created window. This object is the same as any other `window` object except that you typically have more control over it. For instance, some browsers that don't allow you to resize or move the main browser window by default may allow you to resize

or move windows that you've created using `window.open()`. This object can be used to manipulate the newly opened window in the same way as any other window, as shown in this example:

```
let wroxWin = window.open("http://www.wrox.com/",
    "wroxWindow",
    "height=400,width=400,top=10,left=10,resizable=yes");

// resize it
wroxWin.resizeTo(500, 500);

// move it
wroxWin.moveTo(100, 100);
```

It's possible to close the newly opened window by calling the `close()` method as follows:

```
wroxWin.close();
```

This method works only for pop-up windows created by `window.open()`. It's not possible to close the main browser window without confirmation from the user. It is possible, however, for the pop-up window to close itself without user confirmation by calling `top.close()`. Once the window has been closed, the window reference still exists but cannot be used other than to check the `closed` property, as shown here:

```
wroxWin.close();
alert(wroxWin.closed); // true
```

The newly created window object has a reference back to the window that opened it via the `opener` property. This property is defined only on the topmost window object (`top`) of the pop-up window and is a pointer to the window or frame that called `window.open()`. For example:

```
let wroxWin = window.open("http://www.wrox.com/",
    "wroxWindow",
    "height=400,width=400,top=10,left=10,resizable=yes");

alert(wroxWin.opener === window); // true
```

Even though there is a pointer from the pop-up window back to the window that opened it, there is no reverse relationship. Windows do not keep track of the pop-ups that they spawn, so it's up to you to keep track if necessary.

Some browsers, try to run each tab in the browser as a separate process. When one tab opens another, the window objects need to be able to communicate with one another, so the tabs cannot run in separate processes. These browsers allow you to indicate that the newly created tab should be run in a separate process by setting the `opener` property to `null`, as in the following example:

```
let wroxWin = window.open("http://www.wrox.com/",
    "wroxWindow",
    "height=400,width=400,top=10,left=10,resizable=yes");

wroxWin.opener = null;
```

Setting `opener` to `null` indicates to the browser that the newly created tab doesn't need to communicate with the tab that opened it, so it may be run in a separate process. Once this connection has been severed, there is no way to recover it.

Security Restrictions

Pop-up windows went through a period of overuse by advertisers online. Pop-ups were often disguised as system dialogs to get the user to click on an advertisement. Because these pop-up web pages were styled to look like system dialogs, it was unclear to the user whether the dialog was legitimate. To aid in this determination, browsers began putting limits on the configuration of pop-up windows.

Early versions of Internet Explorer implemented multiple security features on pop-up windows, including not allowing pop-up windows to be created or moved offscreen and ensuring that the status bar cannot be turned off. Beginning with Internet Explorer 7, the location bar cannot be turned off and pop-up windows can't be moved or resized by default. Firefox 1 turned off the ability to suppress the status bar, so all pop-up windows have to display the status bar regardless of the feature string passed into `window.open()`. Firefox 3 forces the location bar to always be displayed on pop-up windows. Opera opens pop-up windows only within its main browser window but doesn't allow them to exist where they might be confused with system dialogs.

Additionally, browsers will allow the creation of pop-up windows only after a user action. A call to `window.open()` while a page is still being loaded, for instance, will not be executed and may cause an error to be displayed to the user. Pop-up windows may be opened based only on a click or a key press.

NOTE *Internet Explorer lifts some restrictions on pop-up windows when displaying a web page stored on the computer's hard drive. The same code, when run on a server, will invoke the pop-up restrictions.*

Pop-up Blockers

All modern browsers have pop-up-blocking software built in. The result is that most unexpected pop-ups are blocked. When a pop-up is blocked, one of two things happens. If the browser's built-in pop-up blocker stopped the pop-up, then `window.open()` will most likely return `null`. In that case, you can tell if a pop-up was blocked by checking the return value, as shown in the following example:

```
let wroxWin = window.open("http://www.wrox.com", "_blank");
if (wroxWin == null){
    alert("The popup was blocked!");
}
```

When a browser add-on or other program blocks a pop-up, `window.open()` typically throws an error. So to accurately detect when a pop-up has been blocked, you must check the return value and wrap the call to `window.open()` in a `try-catch` block, as in this example:

```
let blocked = false;

try {
    let wroxWin = window.open("http://www.wrox.com", "_blank");
    if (wroxWin == null){
        blocked = true;
    }
} catch (ex){
    blocked = true;
}
```

```
if (blocked){
    alert("The popup was blocked!");
}
```

This code accurately detects if a pop-up blocker has blocked the call to `window.open()`, regardless of the method being used.

NOTE *Detecting if a pop-up was blocked does not stop the browser from displaying its own message about a pop-up being blocked.*

Intervals and Timeouts

JavaScript execution in a browser is single-threaded but does allow for the scheduling of code to run at specific points in time through the use of timeouts and intervals. Timeouts execute some code after a specified amount of time, whereas intervals execute code repeatedly, waiting a specific amount of time in between each execution.

You set a timeout using the window's `setTimeout()` method, which accepts two arguments: the code to execute and the time (in milliseconds) to wait before scheduling the callback function to be executed. The first argument can be either a string containing JavaScript code (as would be used with `eval()`) or a function. For example:

```
// schedules an alert to show after 1 second
setTimeout(() => alert("Hello world!"), 1000);
```

The second argument, the number of milliseconds to wait, is not necessarily when the specified code will execute. JavaScript is single-threaded and, as such, can execute only one piece of code at a time. To manage execution, there is a queue of JavaScript tasks to execute. The tasks are executed in the order in which they were added to the queue. The second argument of `setTimeout()` tells the JavaScript engine to add this task onto the queue after a set number of milliseconds. If the queue is empty, then that code is executed immediately; if the queue is not empty, the code must wait its turn.

When `setTimeout()` is called, it returns a numeric ID for the timeout. The timeout ID is a unique identifier for the scheduled code that can be used to cancel the timeout. To cancel a pending timeout, use the `clearTimeout()` method and pass in the timeout ID, as in the following example:

```
// set the timeout
let timeoutId = setTimeout(() => alert("Hello world!"), 1000);

// cancel it
clearTimeout(timeoutId);
```

As long as `clearTimeout()` is called before the specified amount of time has passed, a timeout can be canceled completely. Calling `clearTimeout()` after the code has been executed has no effect.

NOTE *All code executed by a timeout using a conventional anonymous function runs in the global scope, so the value of `this` inside the function will always point to `window` when running in nonstrict mode and `undefined` when running in strict mode. When `setTimeout` is instead provided an arrow function, this preserves the lexical scope in which it was defined.*

Intervals work in the same way as timeouts except that they schedule the code for execution repeatedly at specific time intervals until the interval is canceled or the page is unloaded. The `setInterval()` method lets you set up intervals, and it accepts the same arguments as `setTimeout()`: the code to execute (string or function) and the milliseconds to wait between addition of the callback function to the execution queue. Here's an example:

```
setInterval(() => alert("Hello world!"), 10000);
```

NOTE *Importantly, the time interval specified with the second argument represents the amount of time the browser will wait in between adding a new callback execution onto the queue. For example, suppose you invoked `setInterval()` at exactly 01:00:00 with a 3000ms interval. This means that at 01:00:03 the browser would schedule the callback. The browser doesn't care when the callback executes or how long it takes; it will schedule another one at 01:00:06. It follows that short and non-blocking callback functions are ideal for `setInterval`.*

The `setInterval()` method also returns an interval ID that can be used to cancel the interval at some point in the future. The `clearInterval()` method can be used with this ID to cancel all pending intervals. This ability is more important for intervals than timeouts since, if left unchecked, they continue to execute until the page is unloaded. Here is a common example of interval usage:

```
let num = 0, intervalId = null;
let max = 10;

let incrementNumber = function() {
  num++;

  // if the max has been reached, cancel all pending executions
  if (num == max) {
    clearInterval(intervalId);
    alert("Done");
  }
}

intervalId = setInterval(incrementNumber, 500);
```

In this example, the variable `num` is incremented every half second until it finally reaches the maximum number, at which point the interval is canceled. This pattern can also be implemented using timeouts, as shown here:

```
let num = 0;
let max = 10;
```

```

let incrementNumber = function() {
    num++;

    //if the max has not been reached, set another timeout
    if (num < max) {
        setTimeout(incrementNumber, 500);
    } else {
        alert("Done");
    }
}

setTimeout(incrementNumber, 500);

```

Note that when you're using timeouts, it is unnecessary to track the timeout ID because the execution will stop on its own and continue only if another timeout is set. This pattern is considered a best practice for setting intervals without actually using intervals. True intervals are rarely used in production environments because the time between the end of one interval and the beginning of the next is not necessarily guaranteed, and some intervals may be skipped. Using timeouts, as in the preceding example, ensures that can't happen. Generally speaking, it's best to avoid intervals.

System Dialogs

The browser is capable of invoking system dialogs to display to the user through the `alert()`, `confirm()`, and `prompt()` methods. These dialogs are not related to the web page being displayed in the browser and do not contain HTML. Their appearance is determined by operating system and/or browser settings rather than CSS. Additionally, each of these dialogs is synchronous and modal, meaning code execution stops when a dialog is displayed, and resumes after it has been dismissed.

The `alert()` method has been used throughout this book. It simply accepts a string to display to the user. Unlike `console.log`, which can accept a variable number of arguments and display them all at once, `alert` expects only one argument. When `alert()` is called, a system message box displays the specified text to the user, followed by a single OK button. If `alert()` is passed an argument that is not a string primitive, it will coerce the argument into a string with its `toString()` method.

Alert dialogs are typically used when users must be made aware of something that they have no control over, such as an error. A user's only choice is to dismiss the dialog after reading the message. As shown in Figure 12-1.

The second type of dialog is invoked by calling `confirm()`. A confirm dialog looks similar to an alert dialog in that it displays a message to the user. The main difference between the two is the presence of a Cancel button along with the OK button, which allows the user to indicate if a given action should be taken. For example, `confirm("Are you sure?")` displays the confirm dialog box shown in Figure 12-2.

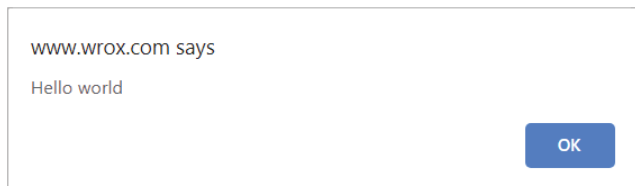

FIGURE 12-1:

To determine if the user clicked OK or Cancel, the `confirm()` method returns a Boolean value: `true` if OK was clicked, or `false` if Cancel was clicked or the dialog box was closed by clicking the X in the corner. Typical usage of a confirm dialog looks like this:

```

if (confirm("Are you sure?")) {
  alert("I'm so glad you're sure!");
} else {
  alert("I'm sorry to hear you're not sure.");
}

```

In this example, the confirm dialog is displayed to the user in the first line, which is a condition of the `if` statement. If the user clicks OK, an alert is displayed saying, “I’m so glad you’re sure!” If, however, the Cancel button is clicked, an alert is displayed saying, “I’m sorry to hear you’re not sure.” This type of pattern can be employed when the user tries to delete something, such as an e-mail message. Because the dialog will totally disrupt the user’s experience on the page, this should be reserved for only actions that have dire consequences.

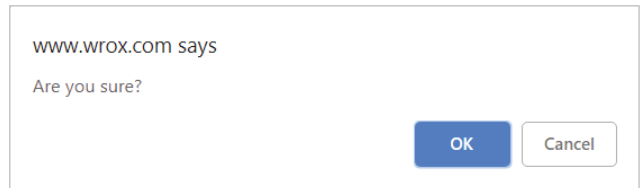

FIGURE 12-2:

The final type of dialog is displayed by calling `prompt()`, which prompts the user for input. Along with OK and Cancel buttons, this dialog has a text box where the user may enter some data. The `prompt()` method accepts two arguments: the text to display to the user, and the default value for the text box (which can be an empty string). Calling `prompt("What is your name?", "Jake")` results in the dialog box shown in Figure 12-3.

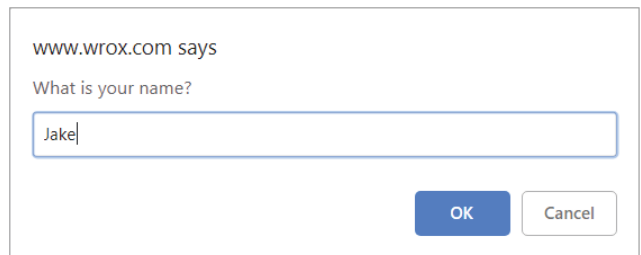

FIGURE 12-3:

If the OK button is clicked, `prompt()` returns the value in the text box; if Cancel is clicked or the dialog is otherwise closed without clicking OK, the function returns `null`. Here’s an example:

```

let result = prompt("What is your name? ", "");
if (result !== null) {
  alert("Welcome, " + result);
}

```

These system dialogs can be helpful for displaying information to the user and asking for confirmation of decisions. Because they require no HTML or CSS, they are fast and easy ways to enhance a web application.

Many browsers have introduced a special feature regarding these system dialogs. If the actively running script produces two or more system dialogs during its execution, each subsequent dialog after the first displays a check box that allows the user to disable any further dialogs until the page reloads.

When the check box is checked and the dialog box is dismissed, all further system dialogs (alerts, confirms, and prompts) are blocked until the page is reloaded. The developer is given no indication as to whether the dialog was displayed. The dialog counter resets whenever the browser is idle, so if two separate user actions produce an alert, the check box will not be displayed in either; if a single user action produces two alerts in a row, the second will contain the check box.

Two other types of dialogs can be displayed from JavaScript: `find` and `print`. Both of these dialogs are displayed asynchronously, returning control to the script immediately. The dialogs are the same as the ones the browser employs when the user selects either Find or Print from the browser's menu. These are displayed using the `find()` and `print()` methods on the `window` object as follows:

```
// display print dialog
window.print();

// display find dialog
window.find();
```

These two methods give no indication as to whether the user has done anything with the dialog, so it is difficult to make good use of them. Furthermore, because they are asynchronous, they don't contribute to the browser's dialog counter and won't be affected by the user opting to disallow further dialogs.

THE LOCATION OBJECT

One of the most useful BOM objects is `location`, which provides information about the document that is currently loaded in the window, as well as general navigation functionality. The `location` object is unique in that it is a property of both `window` and `document`; both `window.location` and `document.location` point to the same object. Not only does `location` know about the currently loaded document, but it also parses the URL into discrete segments that can be accessed via a series of properties. These properties are enumerated in the following table (the `location` prefix is assumed).

If the browser was currently located at `http://foouser:barpassword@www.wrox.com:80/WileyCDA/?q=javascript#contents`, then the `location` object would behave as follows:

PROPERTY NAME	RETURN VALUE	DESCRIPTION
<code>location.hash</code>	"#contents"	The URL hash (the pound sign followed by zero or more characters), or an empty string if the URL doesn't have a hash.
<code>location.host</code>	"www.wrox.com:80"	The name of the server and port number if present.
<code>location.hostname</code>	"www.wrox.com"	The name of the server without the port number.
<code>location.href</code>	"http://www.wrox.com:80/WileyCDA/?q=javascript#contents"	The full URL of the currently loaded page. The <code>toString()</code> method of <code>location</code> returns this value.
<code>location.pathname</code>	"/WileyCDA/"	The directory and/or filename of the URL.
<code>location.port</code>	"80"	The port of the request if specified in the URL. If a URL does not contain a port, then this property returns an empty string.

PROPERTY NAME	RETURN VALUE	DESCRIPTION
<code>location.protocol</code>	"http:"	The protocol used by the page. Typically "http:" or "https:".
<code>location.search</code>	"?q=javascript"	The query string of the URL. It returns a string beginning with a question mark.
<code>location.username</code>	"foouser"	The username specified before the domain name.
<code>location.password</code>	"barpassword"	The password specified before the domain name.
<code>location.origin</code>	"http:// www.wrox.com"	The origin of the URL. Read only.

Query String Arguments

Most of the information in `location` is easily accessible from these properties. The one part of the URL that isn't provided is an easy-to-use query string. Though `location.search` returns everything from the question mark until the end of the URL, there is no immediate access to query-string arguments on a one-by-one basis. The following function parses the query string and returns an object with entries for each argument:

```
let getQueryStringArgs = function() {
  // get query string without the initial '?'
  let qs = (location.search.length > 0 ? location.search.substring(1) : ""),
      // object to hold data
      args = {};

  // assign each item onto the args object
  for (let item of qs.split("&").map(kv => kv.split("="))) {
    let name = decodeURIComponent(item[0]),
        value = decodeURIComponent(item[1]);
    if (name.length) {
      args[name] = value;
    }
  }

  return args;
}
```

The first step in this function is to strip off the question mark from the beginning of the query string. This happens only if `location.search` has one or more characters. The arguments will be stored on the `args` object, which is created using object-literal format. Next, the query string is split on the ampersand character, returning an array of strings in the format `name=value`. The `for` loop iterates over this array and then splits each item on the equal sign, returning an array where the first item is the name of the argument and the second item is the value. The `name` and `value` are each decoded

using `decodeURIComponent()` (because query-string arguments are supposed to be encoded). Last, the name is assigned as a property on the `args` object, and its value is set to `value`. This function is used as follows:

```
// assume query string of ?q=javascript&num=10

let args = getQueryStringArgs();

alert(args["q"]); // "javascript"
alert(args["num"]); // "10"
```

Each of the query-string arguments is now a property on the returned object, which provides fast access to each argument.

URLSearchParams

`URLSearchParams` offers a collection of utility methods which allow you to inspect and modify query parameters using a standardized API. A `URLSearchParams` instance is created by passing a query string to the constructor. The instance exposes various methods like `get()`, `set()`, and `delete()` to perform query string operations. These are demonstrated here:

```
let qs = "?q=javascript&num=10";

let searchParams = new URLSearchParams(qs);

alert(searchParams.toString()); // "q=javascript&num=10"
searchParams.has("num"); // true
searchParams.get("num"); // 10

searchParams.set("page", "3");
alert(searchParams.toString()); // "q=javascript&num=10&page=3"

searchParams.delete("q");
alert(searchParams.toString()); // "num=10&page=3"
```

Most browsers that support `URLSearchParams` also support using the `URLSearchParams` as an iterable object:

```
let qs = "?q=javascript&num=10";

let searchParams = new URLSearchParams(qs);

for (let param of searchParams) {
  console.log(param);
}
// ["q", "javascript"]
// ["num", "10"]
```

Manipulating the Location

The browser location can be changed in a number of ways using the `location` object. The first, and most common, way is to use the `assign()` method and pass in a URL, as in the following example:

```
location.assign("http://www.wrox.com");
```

This immediately starts the process of navigating to the new URL and makes an entry in the browser's history stack. If `location.href` or `window.location` is set to a URL, the `assign()` method is called with the value. For example, both of the following perform the same behavior as calling `assign()` explicitly:

```
window.location = "http://www.wrox.com";
location.href = "http://www.wrox.com";
```

Of these three approaches to changing the browser location, setting `location.href` is most often seen in code.

Changing various properties on the `location` object can also modify the currently loaded page. The `hash`, `search`, `hostname`, `pathname`, and `port` properties can be set with new values that alter the current URL, as in this example:

```
// assume starting at http://www.wrox.com/WileyCDA/

// changes URL to "http://www.wrox.com/WileyCDA/#section1"
location.hash = "#section1";

// changes URL to "http://www.wrox.com/WileyCDA/?q=javascript"
location.search = "?q=javascript";

// changes URL to "http://www.yahoo.com/WileyCDA/"
location.hostname = "www.yahoo.com";

// changes URL to "http://www.yahoo.com/mydir/"
location.pathname = "mydir";

// changes URL to "http://www.yahoo.com:8080/WileyCDA/"
location.port = 8080;
```

Each time a property on `location` is changed, with the exception of `hash`, the page reloads with the new URL.

NOTE *Changing the value of `hash` causes a new entry in the browser's history to be recorded. In earlier Internet Explorer versions, the `hash` property was updated not when Back or Forward was clicked but only when a link containing a hashed URL was clicked.*

When the URL is changed using one of the previously mentioned approaches, an entry is made in the browser's history stack so the user may click the Back button to navigate to the previous page. It is possible to disallow this behavior by using the `replace()` method. This method accepts a single argument, the URL to navigate to, but does not make an entry in the history stack. After calling `replace()`, the user cannot go back to the previous page. Consider this example:

```
<!DOCTYPE html>
<html>
<head>
  <title>You won't be able to get back here</title>
</head>
```

```

<body>
  <p>Enjoy this page for a second, because you won't be coming back here.</p>
  <script>
    setTimeout(() => location.replace("http://www.wrox.com/"), 1000);
  </script>
</body>
</html>

```

If this page is loaded into a web browser, it will redirect to `www.wrox.com` after a second. At that point, the Back button will be disabled, and you won't be able to navigate back to this example page without typing in the complete URL again.

The last method of `location` is `reload()`, which reloads the currently displayed page. When `reload()` is called with no argument, the page is reloaded in the most efficient way possible, which is to say that the page may be reloaded from the browser cache if it hasn't changed since the last request. To force a reload from the server, pass in `true` as an argument like this:

```

location.reload();      // reload - possibly from cache
location.reload(true); // reload - go back to the server

```

Any code located after a `reload()` call may or may not be executed, depending on factors such as network latency and system resources. For this reason, it is best to have `reload()` as the last line of code.

THE NAVIGATOR OBJECT

Originally introduced in Netscape Navigator 2, the `navigator` object is the standard for browser identification on the client. The `navigator` object is common among all JavaScript-enabled web browsers. As with other BOM objects, each browser supports its own set of properties.

NOTE *The navigator object properties which offer insight into system capabilities are detailed further in the Client Detection chapter.*

The `navigator` object implements methods and properties defined in the `NavigatorID`, `NavigatorLanguage`, `NavigatorOnLine`, `NavigatorContentUtils`, `NavigatorStorage`, `NavigatorStorageUtils`, `NavigatorConcurrentHardware`, `NavigatorPlugins`, and `NavigatorUserMedia` interfaces.

The following table lists each available property and method:

PROPERTY/METHOD	DESCRIPTION
<code>activeVrDisplays</code>	Returns an array of every <code>VrDisplay</code> instance with its <code>isPresenting</code> property set to <code>true</code> .
<code>appName</code>	Returns "Mozilla" even in non-Mozilla browsers.
<code>appName</code>	Full browser name.

PROPERTY/METHOD	DESCRIPTION
<code>appVersion</code>	Browser version. Typically does not correspond to the actual browser version.
<code>battery</code>	Returns a <code>BatteryManager</code> object to interact with the Battery Status API.
<code>buildId</code>	Build number for the browser.
<code>connection</code>	Returns a <code>NetworkInformation</code> object to interact with the Network Information API.
<code>cookieEnabled</code>	Indicates if cookies are enabled.
<code>credentials</code>	A <code>CredentialsContainer</code> to interact with the Credentials Management API.
<code>deviceMemory</code>	The amount of device memory in gigabytes.
<code>doNotTrack</code>	The user's do-not-track preference.
<code>geolocation</code>	A <code>Geolocation</code> object to interact with the Geolocation API.
<code>getVRDisplays()</code>	Returns an array of every <code>VRDisplay</code> instance available.
<code>getUserMedia()</code>	Returns the stream associated with the available media device hardware.
<code>hardwareConcurrency</code>	The device's number of processor cores.
<code>javaEnabled</code>	Indicates if Java is enabled in the browser.
<code>language</code>	The browser's primary language.
<code>languages</code>	An array of all the browser's preferred languages.
<code>locks</code>	A <code>LockManager</code> object to interact with the Web Locks API.
<code>mediaCapabilities</code>	A <code>MediaCapabilities</code> object to interact with the Media Capabilities API.
<code>mediaDevices</code>	The available media devices.
<code>maxTouchPoints</code>	The maximum number of supported touch points for the device's touchscreen.
<code>mimeTypes</code>	Array of MIME types registered with the browser.
<code>onLine</code>	Indicates if the browser is connected to the Internet.
<code>oscpu</code>	The operating system and/or CPU on which the browser is running.
<code>permissions</code>	A <code>Permissions</code> object to interact with the Permissions API.

continues

(continued)

PROPERTY/METHOD	DESCRIPTION
<code>platform</code>	The system platform on which the browser is running.
<code>plugins</code>	Array of plug-ins installed on the browser. In Internet Explorer only, this is an array of all <code><embed></code> elements on the page.
<code>product</code>	The name of the product (typically "Gecko").
<code>productSub</code>	Extra information about the product (typically Gecko version information).
<code>registerProtocolHandler()</code>	Registers a website as a handler for a particular protocol.
<code>requestMediaKeySystemAccess()</code>	Returns a <code>Promise</code> which resolves to a <code>MediaKeySystemAccess</code> object.
<code>sendBeacon()</code>	Asynchronously transmits a small payload.
<code>serviceWorker</code>	The <code>ServiceWorkerContainer</code> used to interact with <code>ServiceWorker</code> objects.
<code>share()</code>	If available, invokes the current platform's native sharing mechanism.
<code>storage</code>	Returns the <code>StorageManager</code> object to interact with the Storage API.
<code>userAgent</code>	The user-agent string for the browser.
<code>vendor</code>	The brand name of the browser.
<code>vendorSub</code>	Extra information about the vendor.
<code>vibrate()</code>	Triggers the device to vibrate if vibration is supported.
<code>webdriver</code>	Indicates if the browser is controlled by automation.

The `navigator` object's properties are typically used to determine the type of browser that is running a web page.

Detecting Plug-ins

One of the most common detection procedures is to determine whether the browser has a particular plug-in installed. For browsers other than Internet Explorer 10 and below, this can be determined using the `plugins` array. Each item in the array contains the following properties:

- `name`—The name of the plug-in
- `description`—The description of the plug-in
- `filename`—The filename for the plug-in
- `length`—The number of MIME types handled by this plug-in

Typically, the name contains all of the information that's necessary to identify a plug-in, though this is not an exact science. Plug-in detection is done by looping over the available plug-ins and comparing a plug-in's name to a given name, as in this example:

```
// plugin detection - doesn't work in Internet Explorer 10 or below
let hasPlugin = function(name) {
  name = name.toLowerCase();
  for (let plugin of window.navigator.plugins){
    if (plugin.name.toLowerCase().indexOf(name) > -1){
      return true;
    }
  }

  return false;
}

// detect flash
alert(hasPlugin("Flash"));

// detect quicktime
alert(hasPlugin("QuickTime"));
```

The `hasPlugin()` example accepts a single argument: the name of a plug-in to detect. The first step is to convert that name to lowercase for easier comparison. Next, the `plugins` array is iterated over, and each `name` property is checked via `indexOf()` to see if the passed-in name appears somewhere in that string. This comparison is done in all lowercase to avoid casing errors. The argument should be as specific as possible to avoid confusion. Strings such as "Flash" and "QuickTime" are unique enough that there should be little confusion. This method works for detecting plug-ins in Firefox, Safari, Opera, and Chrome.

NOTE *Each plugin object is also an array of `MimeType` objects that can be accessed using bracket notation. Each `MimeType` object has four properties: `description`, which is a description of the MIME type; `enabledPlugin`, which is a pointer back to the plugin object; `suffixes`, which is a comma-delimited string of file extensions for the MIME type; and `type`, which is the full MIME type string.*

With the release of Internet Explorer 11, `window.navigator` supports `plugins` and `mimeType`s. This means that the function defined previously is capable of detecting plug-ins properly for all up-to-date versions of browsers from major vendors. Furthermore, the `ActiveXObject` becomes hidden from the DOM in IE11, meaning it cannot be used for detection purposes.

Legacy Internet Explorer Plugin Detection

Detecting plug-ins in Internet Explorer 10 or below is more problematic because it doesn't support Netscape-style plug-ins. The only way to detect plug-ins in Internet Explorer is to use the proprietary `ActiveXObject` type and attempt to instantiate a particular plug-in. Plug-ins are implemented in Internet Explorer using COM objects, which are identified by unique strings. So to check for a

particular plug-in, you must know its COM identifier. For instance, the identifier for Flash is "ShockwaveFlash.ShockwaveFlash". With this information, you can write a function to determine if the plug-in is installed in Internet Explorer as follows:

```
// plugin detection for legacy Internet Explorer
function hasIEPlugin(name) {
    try {
        new ActiveXObject(name);
        return true;
    } catch (ex) {
        return false;
    }
}

// detect flash
alert(hasIEPlugin("ShockwaveFlash.ShockwaveFlash"));

// detect quicktime
alert(hasIEPlugin("QuickTime.QuickTime"));
```

In this example, the `hasIEPlugin()` function accepts a COM identifier as its sole argument. In the function, an attempt is made to create a new `ActiveXObject` instance. This is encapsulated in a `try-catch` statement because an attempt to create an unknown COM object will throw an error. Therefore, if the attempt is successful, the function returns `true`. If there is an error, the `catch` block gets executed, which returns `false`. This code then checks to see if the Flash and QuickTime plug-ins are available in Internet Explorer.

Because these two plug-in-detection methods are so different, it's typical to create functions that test for specific plug-ins rather than use the generic methods described previously. Consider this example:

```
// detect flash for all browsers
function hasFlash() {
    var result = hasPlugin("Flash");
    if (!result){
        result = hasIEPlugin("ShockwaveFlash.ShockwaveFlash");
    }
    return result;
}

// detect quicktime for all browsers
function hasQuickTime() {
    var result = hasPlugin("QuickTime");
    if (!result){
        result = hasIEPlugin("QuickTime.QuickTime");
    }
    return result;
}

// detect flash
alert(hasFlash());

// detect quicktime
alert(hasQuickTime());
```

This code defines two functions: `hasFlash()` and `hasQuickTime()`. Each function attempts to use the non-Internet Explorer plug-in-detection code first. If that method returns `false` (which it will for Internet Explorer), the Internet Explorer plug-in-detection method is called. If the Internet Explorer plug-in-detection method also returns `false`, then the result of the overall method is `false`. If either plug-in-detection function returns `true`, then the overall method returns `true`.

NOTE *The `plugins` collection has a method called `refresh()`, which refreshes plugins to reflect any newly installed plug-ins. This method accepts a single argument: a Boolean value indicating if the page should be reloaded. When set to `true`, all pages containing plug-ins are reloaded; otherwise the `plugins` collection is updated, but the page is not reloaded.*

Registering Handlers

Modern browsers formally support the `registerProtocolHandler()` method to the `navigator` object. (This is formally defined in HTML 5.) These methods allow a website to indicate that it can handle specific types of information. With the rise of online RSS readers and online e-mail applications, this is a way for those applications to be used by default just as desktop applications are used.

A call can be made for protocols by using `registerProtocolHandler()`, which accepts three arguments: the protocol to handle (i.e., "mailto" or "ftp"), the URL of the page that handles the protocol, and the name of the application. For example, to register a web application as the default mail client, you can use the following:

```
navigator.registerProtocolHandler("mailto",
    "http://www.somemailclient.com?cmd=%s",
    "Some Mail Client");
```

In this example, a handler is registered for the `mailto` protocol, which will now point to a web-based e-mail client. Once again, the second argument is the URL that should handle the request, and `%s` represents the original request.

THE SCREEN OBJECT

The `screen` object (also a property of `window`) is one of the few JavaScript objects that have little to no programmatic use; it is used purely as an indication of client capabilities. This object provides information about the client's display outside the browser window, including information such as pixel width and height. Each browser provides different properties on the `screen` object. The following table describes each of the properties.

PROPERTY	DESCRIPTION
<code>availHeight</code>	The pixel height of the screen minus system elements such as Windows (read only).
<code>availLeft</code>	The first pixel from the left that is not taken up by system elements (read only).

continues

(continued)

PROPERTY	DESCRIPTION
<code>availTop</code>	The first pixel from the top that is not taken up by system elements (read only).
<code>availWidth</code>	The pixel width of the screen minus system elements (read only).
<code>colorDepth</code>	The number of bits used to represent colors; for most systems, 32 (read only).
<code>height</code>	The pixel height of the screen.
<code>left</code>	The pixel distance of the current screen's left side.
<code>pixelDepth</code>	The bit depth of the screen (read only).
<code>top</code>	The pixel distance of the current screen's top.
<code>width</code>	The pixel width of the screen.
<code>orientation</code>	Returns the screen orientation as specified in the Screen Orientation API.

THE HISTORY OBJECT

The `history` object represents the user's navigation history since the given window was first used. Because `history` is a property of `window`, each browser window object has its own `history` object relating specifically to that instance. For security reasons, it's not possible to determine the URLs that the user has visited. It is possible, however, to navigate backwards and forwards through the list of places the user has been without knowing the exact URL.

Navigation

The `go()` method navigates through the user's history in either direction, backward or forward. This method accepts a single argument, which is an integer representing the number of pages to go backward or forward. A negative number moves backward in history (similar to clicking the browser's Back button), and a positive number moves forward (similar to clicking the browser's Forward button). Here's an example:

```
// go back one page
history.go(-1);

// go forward one page
history.go(1);

// go forward two pages
history.go(2);
```

The `go()` method argument can also be a string, in which case the browser navigates to the first location in history that contains the given string. The closest location may be either backward or forward. If there's no entry in history matching the string, then the method does nothing, as in this example:

```
// go to nearest wrox.com page
history.go("wrox.com");
```



```
// go to nearest nczonline.net page
history.go("nczonline.net");
```

Two shortcut methods, `back()` and `forward()`, may be used in place of `go()`. As you might expect, these mimic the browser Back and Forward buttons as follows:

```
// go back one page
history.back();

// go forward one page
history.forward();
```

The `history` object also has a property, `length`, which indicates how many items are in the `history` stack. This property reflects all items in the history stack, both those going backward and those going forward. For the first page loaded into a window or tab, `history.length` is equal to 0. By testing for this value as shown here, it's possible to determine if the user's start point was your page:

```
if (history.length == 0){
  //this is the first page in the user's window
}
```

The `history` object typically is used to create custom Back and Forward buttons and to determine if the page is the first in the user's history.

NOTE *Entries are made in the history stack whenever the page's URL changes. For major browsers released since 2009, this includes changes to the URL hash (thus, setting `location.hash` causes a new entry to be inserted into the history stack for these browsers). This behavior is commonly used by single-page application frameworks, which wish to simulate Back and Forward button functionality without causing full page reloads upon each navigation event.*

History State Management

One of the most difficult aspects of modern web application programming is history management. Gone are the days where every action takes a user to a completely new page, which also means that the Back and Forward buttons have been taken away from users as a familiar way to say “get me to a different state.” The first step to solving that problem was the `hashchange` event (discussed in the *Events* chapter). HTML5 updates the `history` object to provide easy state management.

Where the `hashchange` event simply let you know when the URL hash changed and expected you to act accordingly, the state management API actually lets you change the browser URL without loading a new page. To do so, use the `history.pushState()` method. This method accepts three arguments: a data object, the title of the new state, and an optional relative URL. For example:

```
let stateObject = {foo:"bar"};

history.pushState(stateObject, "My title", "baz.html");
```

As soon as `pushState()` executes, the state information is pushed onto the history stack and the browser's address bar changes to reflect the new relative URL. Despite this change, the browser does not make a request to the server, even though querying `location.href` will return exactly what's in

the address bar. The second argument isn't currently used by any implementations and so it is safe to either leave it as an empty string or provide a short title. The first argument should contain all of the information necessary to correctly initialize this page state when necessary. To prevent abuse, the size of the state object is limited, typically to less than 500MB–1MB.

Since `pushState()` creates a new history entry, you'll notice that the Back button is enabled. When the Back button is pressed, the `popstate` event fires on the `window` object. The event object for `popstate` has a property called `state`, which contains the object that was passed into `pushState()` as the first argument:

```
window.addEventListener("popstate", (event) => {
  let state = event.state;
  if (state) { // state is null when at first page load
    processState(state);
  }
});
```

Using this state, you must then reset the page into the state represented by the data in the state object (as the browser doesn't do this automatically for you). Keep in mind that when a page is first loaded, there is no state, so hitting the Back button until you get to the original page state will result in `event.state` being `null`.

You can access the current state object by using `history.state`. You can also update the current state information by using `replaceState()` and passing in the same first two arguments as `pushState()`. Doing so does not create a new entry in history, it just overwrites the current state:

```
history.replaceState({newFoo: "newBar"}, "New title");
```

The state object passed into `pushState()` or `replaceState()` should only contain information that can be serialized. Therefore, things like DOM elements are inappropriate for use in the state object.

NOTE *When using HTML5 history state management, make sure that any "fake" URL you create using `pushState()` is backed up by a real, physical URL on the web server. Otherwise, hitting the Refresh button will result in a 404. All single-page application (SPA) frameworks must address this problem in some way via configuration on the server or client.*

SUMMARY

The Browser Object Model (BOM) is based on the `window` object, which represents the browser window and the viewable page area. The `window` object doubles as the ECMAScript `Global` object, so all global variables and functions become properties on it, and all native constructors and functions exist on it initially. This chapter discussed the following elements of the BOM:

- To reference other window objects, there are several window pointers.
- The `location` object allows programmatic access to the browser's navigation system. By setting properties, it's possible to change the browser's URL piece by piece or altogether.

- The `replace()` method allows for navigating to a new URL and replacing the currently displayed page in the browser's history.
- The `navigator` object provides information about the browser. The type of information provided depends largely on the browser being used, though some common properties, such as `userAgent`, are available in all browsers.

Two other objects available in the BOM perform very limited functions. The `screen` object provides information about the client display. This information is typically used in metrics gathering for websites. The `history` object offers a limited peek into the browser's history stack, allowing developers to determine how many sites are in the history stack and giving them the ability to go back or forward to any page in the history, as well as modify the history stack.

13

Client Detection

WHAT'S IN THIS CHAPTER?

- Using capability detection
- The history of user-agent detection
- Software and hardware detection
- When to use each type of detection

Although browser vendors have made a concerted effort to implement common interfaces, the fact remains that each browser presents its own capabilities and flaws. Browsers that are available cross-platform often have different issues, even though they are technically the same version. These differences force web developers to either design for the lowest common denominator or, more commonly, use various methods of client detection to work with or around limitations.

Client detection remains one of the most controversial topics in web development. The idea that browsers should support a common set of functionality pervades most conversations on the topic. In an ideal world, this would be the case. In reality, however, there are enough browser differences and quirks that client detection becomes not just an afterthought but also a vital part of the development strategy. The browser differences of today are much less pronounced than the Internet Explorer fiasco of yesteryear, but browser inconsistencies remain a common theme in web development.

There are several approaches you can use to determine the web client being used, and each has advantages and disadvantages. It's important to understand that client detection should be the very last step in solving a problem; whenever a more common solution is available, that solution should be used. Design for the most common solution first and then augment it with browser-specific solutions later.

CAPABILITY DETECTION

Capability detection (also called feature detection) uses a suite of simple checks in the browser's JavaScript runtime to test for support of various features. This approach presumes that specific browser knowledge is unnecessary and that the solution may be found by determining if the capability in question actually exists. The basic pattern for capability detection is as follows:

```
if (object.propertyInQuestion) {
  // use object.propertyInQuestion
}
```

For example, the DOM method `document.getElementById()` didn't exist in Internet Explorer prior to version 5, although the same functionality could be achieved using the nonstandard `document.all` property. This led to a capability detection fork such as the following:

```
function getElement(id) {
  if (document.getElementById) {
    return document.getElementById(id);
  } else if (document.all) {
    return document.all[id];
  } else {
    throw new Error("No way to retrieve element!");
  }
}
```

The purpose of the `getElement()` function is to return an element with the given ID. Because `document.getElementById()` is the standard way of achieving this, it is tested for first. If the function exists (it isn't undefined), then it is used. Otherwise, a check is done to determine if `document.all` is available, and if so, that is used. If neither method is available (which is highly unlikely), an error is thrown to indicate that the function won't work.

There are two important concepts to understand in capability detection. As just mentioned, the most common way to achieve the result should be tested for first. In the previous example, this meant testing for `document.getElementById()` before `document.all`. Testing for the most common solution ensures optimal code execution by avoiding multiple-condition testing in the common case.

The second important concept is that you must test for exactly what you want to use. Just because one capability exists doesn't necessarily mean another exists. Consider the following example:

```
function getWindowWidth() {
  if (document.all) { // assumes IE
    return document.documentElement.clientWidth; // INCORRECT USAGE!!!
  } else {
    return window.innerWidth;
  }
}
```

This example shows an incorrect usage of capability detection. The `getWindowWidth()` function first checks to see if `document.all` exists. It does, so the function then returns `document.documentElement.clientWidth`. Internet Explorer 8 and earlier versions do not support the `window.innerWidth` property. The problem in this code is that a test for `document.all` does not necessarily

indicate that the browser is Internet Explorer. It could, in fact, be an early version of Opera, which supported `document.all` and `window.innerWidth`.

Safer Capability Detection

Capability detection is most effective when you verify not just that the feature is present but also that the feature is likely to behave in an appropriate manner. The examples in the previous section rely on type coercion of the tested object member to make a determination as to its presence. While this tells you about the presence of the object member, there is no indication if the member is the one you're expecting. Consider the following function, which tries to determine if an object is sortable:

```
// AVOID! Incorrect capability detection - only checks for existence
function isSortable(object) {
    return !!object.sort;
}
```

This function attempts to determine that an object can be sorted by checking for the presence of the `sort()` method. The problem is that any object with a `sort` property will also return `true`:

```
let result = isSortable({ sort: true });
```

Simply testing for the existence of a property doesn't definitively indicate that the object in question is sortable. The better approach is to check that `sort` is actually a function:

```
// Better - checks if sort is a function
function isSortable(object) {
    return typeof object.sort == "function";
}
```

The `typeof` operator is used in this code to determine that `sort` is actually a function and therefore can be called to sort the data contained within.

Capability detection using `typeof` is preferred whenever possible, but it is not infallible. In particular, host objects are under no obligation to return rational values for `typeof`. The most egregious example of this occurs with Internet Explorer. In most browsers, the following code returns `true` if `document.createElement()` is present:

```
// doesn't work properly in Internet Explorer <= 8
function hasCreateElement() {
    return typeof document.createElement == "function";
}
```

In Internet Explorer 8 and earlier, the function returns `false` because `typeof document.createElement` returns `"object"` instead of `"function"`. As mentioned previously, DOM objects are host objects, and host objects are implemented via COM instead of JavaScript in Internet Explorer 8 and earlier. As such, the actual function `document.createElement()` is implemented as a COM object and `typeof` then returns `"object"`. Internet Explorer 9 correctly returns `"function"` for DOM methods.

NOTE For an exhaustive discussion of the ins and outs of capability detection in JavaScript, please see Peter Michaux's article "Feature Detection: State of the Art Browser Scripting" at <http://peter.michaux.ca/articles/feature-detection-state-of-the-art-browser-scripting>.

Using Capability Detection for Browser Analysis

Although some might consider reliance on capability detection to be somewhat of a hack, proper application of capability detection can yield a surprisingly accurate analysis of the browser executing the code. The advantage of using capability detection over user-agents to identify a browser is that, while it is exceptionally easy to spoof a user-agent, it is much harder to conceal all the capabilities of a browser in a way that can reliably fool capability detection tests.

Detecting Feature Support

It is possible to group capabilities together into classes of browsers. If you know that your application needs to use specific browser functionality, it may be useful to do detection for all of the capabilities once rather than doing it repeatedly. Consider this example:

```
// determine if the browser has Netscape-style plugins
let hasNSPlugins = !(navigator.plugins && navigator.plugins.length);

// determine if the browser has basic DOM Level 1 capabilities
let hasDOM1 = !(document.getElementById && document.createElement &&
    document.getElementsByTagName);
```

In this example, two detections are done: one to see if the browser supports Netscape-style plug-ins, and one to determine if the browser supports basic DOM Level 1 capabilities. These Boolean values can later be queried, and it will take less time than it would to retest the capabilities.

Detecting Browser Identity

It is also possible to test a browser for support of various features and compare the results against a known collection to ascertain which browser is in use. This allows for a detection scheme that is safe from user-agent spoofing (discussed later in the chapter), but future versions of browsers may break your capability detection scheme.

Consider the following example, which tests for known unique behavior of various browsers to infer the browser the code is running inside. This code intentionally does not make use of `navigator.userAgent`, which is discussed later in the chapter:

```
class BrowserDetector {
  constructor() {
    // Test for conditional compilation
    // Supported IE6 to IE10
    this.isIE_Gte6Lte10 = /*@cc_on!@*/false;

    // Test for presence of documentMode
    // Supported IE7 to IE11
    this.isIE_Gte7Lte11 = !!document.documentMode;

    // Test for presence of StyleMedia constructor
    // Supported Edge >= 20
    this.isEdge_Gte20 = !!window.StyleMedia;

    // Test for proprietary Firefox add-on install API
    // Supported for all Firefox versions
    this.isFirefox_Gte1 = typeof InstallTrigger !== 'undefined';
```

```

// Test for presence of Chrome object and its webstore property. Versions
// of Opera will have window.chrome, but not window.chrome.webstore
// Supported for all Chrome versions
this.isChrome_Gte1 = !!window.chrome && !!window.chrome.webstore;

// Early versions of Safari would append "Constructor" to the constructor
// function identifier.
// window.Element.toString(); // [object ElementConstructor]
// Supported Safari 3 to 9.1
this.isSafari_Gte3Lte9_1 = /constructor/i.test(window.Element);

// Push notification API exposed on window object. Uses default parameters
// to prevent stringification of undefined values.
// Supported Safari 7.1+
this.isSafari_Gte7_1 =
    (({pushNotification = {}} = {}) =>
        pushNotification.toString() == '[object SafariRemoteNotification]'
    )(window.safari);

// Tests for the 'addons' property.
// Supported Opera 20+
this.isOpera_Gte20 = !!window.opr && !!window.opr.addons;
}

isIE() { return this.isIE_Gte6Lte10 || this.isIE_Gte7Lte11; }
isEdge() { return this.isEdge_Gte20 && !this.isIE(); }
isFirefox() { return this.isFirefox_Gte1; }
isChrome() { return this.isChrome_Gte1; }
isSafari() { return this.isSafari_Gte3Lte9_1 || this.isSafari_Gte7_1; }
isOpera() { return this.isOpera_Gte20; }
}

```

Using such a class allows you to expose generalized browser detection methods that combine capability detection for different browser ranges. As browsers shift and evolve, you can adjust the underlying capability detection while leaving the primary API intact.

Capability Detection Limitations

Detecting a particular capability or set of capabilities does not necessarily indicate the browser in use. The following "browser detection" code, or something similar, can be found on numerous websites and is an example of improper capability detection:

```

// AVOID! Not specific enough
let isFirefox = !(navigator.vendor && navigator.vendorSub);

// AVOID! Makes too many assumptions
let isIE = !(document.all && document.uniqueID);

```

This code represents a classic misuse of capability detection. In the past, Firefox could be determined by checking for `navigator.vendor` and `navigator.vendorSub`, but then Safari came along and implemented the same properties, meaning this code would give a false positive. To detect Internet Explorer, the code checks for the presence of `document.all` and `document.uniqueID`. This assumes

that both of these properties will continue to exist in future versions of IE and won't ever be implemented by any other browser. Both checks use a double NOT operator to produce a Boolean result (which is more optimal to store and access).

NOTE *Capability detection is best used to determine the next step in a solution, not necessarily as a flag indicating a particular browser is being used.*

USER-AGENT DETECTION

User-agent detection uses the browser's user-agent string to determine information about the browser being used. The user-agent string is sent as a response header for every HTTP request and is made accessible in JavaScript through `navigator.userAgent`. On the server side, it is a common and accepted practice to look at the user-agent string to determine the browser being used and to act accordingly. On the client side, however, user-agent detection should be assumed to be unreliable and used in scenarios when other options are infeasible.

Among the controversial aspects of the user-agent string is its long history of *spoofing*, when browsers try to fool servers by including erroneous or misleading information in their user-agent string. To understand this problem, it's necessary to take a look back at how the user-agent string has evolved since the Web first appeared.

History of User-Agent Composition

The HTTP specification, both versions 1.0 and 1.1, indicates that browsers should send short user-agent strings specifying the browser name and version. RFC 2616 (the HTTP 1.1 protocol specification) describes the user-agent string in this way:

Product tokens are used to allow communicating applications to identify themselves by software name and version. Most fields using product tokens also allow sub-products which form a significant part of the application to be listed, separated by white space. By convention, the products are listed in order of their significance for identifying the application.

The specification further stipulates that the user-agent string should be specified as a list of products in the form token/product version. In reality, however, user-agent strings have never been that simple.

Early Browsers

The first web browser, Mosaic, was released in 1993 by the National Center for Supercomputing Applications (NCSA). Its user-agent string was fairly simple, taking a form similar to this:

```
Mosaic/0.9
```

Though this would vary depending on the operating system and platform, the basic format was simple and straightforward. The text before the forward slash indicates the product name (sometimes appearing as NCSA Mosaic or other derivatives), and the text after the slash is the product version.

When Netscape Communications began developing its web browser, its code name was Mozilla (short for "Mosaic Killer"). Netscape Navigator 2, the first publicly available version, had a user-agent string with the following format:

```
Mozilla/Version [Language] (Platform; Encryption)
```

Netscape kept the tradition of using the product name and version as the first part of the user-agent string but added the following information afterward:

- **Language**—The language code indicating where the application was intended to be used.
- **Platform**—The operating system and/or platform on which the application is running.
- **Encryption**—The type of security encryption included. Possible values are U (128-bit encryption), I (40-bit encryption), and N (no encryption).

A typical user-agent string from Netscape Navigator 2 looked like this:

```
Mozilla/2.02 [fr] (WinNT; I)
```

This string indicates Netscape Navigator 2.02 is being used, is compiled for use in French-speaking countries, and is being run on Windows NT with 40-bit encryption. Overall, it was fairly easy to determine what browser was being used just by looking at the product name in the user-agent string.

Netscape Navigator 3 and Internet Explorer 3

In 1996, Netscape Navigator 3 was released and became the most popular web browser, surpassing Mosaic. The user-agent string went through only a small change, removing the language token and allowing optional information about the operating system or CPU used on the system. The format became the following:

```
Mozilla/Version (Platform; Encryption [; OS-or-CPU description])
```

A typical user-agent string for Netscape Navigator 3 running on a Windows system looked like this:

```
Mozilla/3.0 (Win95; U)
```

This string indicates Netscape Navigator 3 running on Windows 95 with 128-bit encryption. Note that the OS or CPU description was left off when the browser ran on Windows systems.

Shortly after the release of Netscape Navigator 3, Microsoft released its first publicly available web browser, Internet Explorer 3. Because Netscape was the dominant browser at the time, many servers specifically checked for it before serving up pages. The inability to access pages in Internet Explorer would have crippled adoption of the fledgling browser, so the decision was made to create a user-agent string that would be compatible with the Netscape user-agent string. The result was the following format:

```
Mozilla/2.0 (compatible; MSIE Version; Operating System)
```

For example, Internet Explorer 3.02 running on Windows 95 had this user-agent string:

```
Mozilla/2.0 (compatible; MSIE 3.02; Windows 95)
```

Because most browser sniffers at the time looked only at the product-name part of the user-agent string, Internet Explorer successfully identified itself as Mozilla, the same as Netscape Navigator. This move caused some controversy because it broke the convention of browser identification. Furthermore, the true browser version is buried in the middle of the string.

Another interesting part of this string is the identification of Mozilla 2.0 instead of 3.0. Because 3.0 was the dominant browser at the time, it would have made more sense to use that. The actual reason remains a mystery—it was more likely an oversight than anything else.

Netscape Communicator 4 and Internet Explorer 4 Through 8

In August 1997, Netscape Communicator 4 was released (the name was changed from *Navigator* to *Communicator* for this release). Netscape opted to keep the following user-agent string format from version 3:

```
Mozilla/Version (Platform; Encryption [; OS-or-CPU description])
```

With version 4 on a Windows 98 machine, the user-agent string looked like this:

```
Mozilla/4.0 (Win98; I)
```

As Netscape released patches and fixes for its browser, the version was incremented accordingly, as the following user-agent string from version 4.79 indicates:

```
Mozilla/4.79 (Win98; I)
```

When Microsoft released Internet Explorer 4, the user-agent string featured an updated version, taking the following format:

```
Mozilla/4.0 (compatible; MSIE Version; Operating System)
```

For example, Internet Explorer 4 running on Windows 98 returned the following user-agent string:

```
Mozilla/4.0 (compatible; MSIE 4.0; Windows 98)
```

With this change, the reported Mozilla version and the actual version of Internet Explorer were synchronized, allowing for easy identification of these fourth-generation browsers. Unfortunately, the synchronization ended there. When Internet Explorer 4.5 (released only for Macs) debuted, the Mozilla version remained 4 while the Internet Explorer version changed as follows:

```
Mozilla/4.0 (compatible; MSIE 4.5; Mac_PowerPC)
```

In Internet Explorer versions through version 7, the following pattern has remained:

```
Mozilla/4.0 (compatible; MSIE 7.0; Windows NT 5.1)
```

Internet Explorer 8 introduced an additional token called Trident, which is the name of the rendering engine. The format became:

```
Mozilla/4.0 (compatible; MSIE Version; Operating System; Trident/TridentVersion)
```

For example:

```
Mozilla/4.0 (compatible; MSIE 8.0; Windows NT 5.1; Trident/4.0)
```

The extra Trident token is designed to help developers determine when Internet Explorer 8 is running in compatibility mode. In that case, the MSIE version becomes 7, but the Trident version remains in the user-agent string:

```
Mozilla/4.0 (compatible; MSIE 7.0; Windows NT 5.1; Trident/4.0)
```

Adding this extra token makes it possible to determine if a browser is Internet Explorer 7 (in which case there is no Trident token) or Internet Explorer 8 running in compatibility mode.

Internet Explorer 9 slightly changed this format. The Mozilla version was incremented to 5.0, and the Trident version was also incremented to 5.0. The default user-agent string for Internet Explorer 9 looks like this:

```
Mozilla/5.0 (compatible; MSIE 9.0; Windows NT 6.1; Trident/5.0)
```

When Internet Explorer 9 runs in compatibility mode, the old Mozilla version and MSIE version are restored while the Trident version remains at 5.0. For example, the following user-agent string is Internet Explorer 9 running in Internet Explorer 7 compatibility mode:

```
Mozilla/4.0 (compatible; MSIE 7.0; Windows NT 6.1; Trident/5.0)
```

All of these changes were made to ensure that past user-agent detection scripts continue to work correctly while enabling new scripts to have additional information.

Gecko

The Gecko rendering engine is at the heart of Firefox. When Gecko was first developed, it was as part of the generic Mozilla browser that was to become Netscape 6. A specification was written for Netscape 6, indicating how the user-agent string should be constructed in all future versions. The new format represented a fairly drastic departure from its relatively simple user-agent string used through version 4.x. The format is as follows:

```
Mozilla/MozillaVersion (Platform; Encryption; OS-or-CPU; Language;  
PrereleaseVersion) Gecko/GeckoVersion  
ApplicationProduct/ApplicationProductVersion
```

A lot of thought went into this remarkably complex user-agent string. The following table lists the meaning of each section.

STRING	REQUIRED?	DESCRIPTION
<i>MozillaVersion</i>	Yes	The version of Mozilla.
<i>Platform</i>	Yes	The platform on which the browser is running. Possible values include Windows, Mac, and X11 (for Unix X-windows systems).
<i>Encryption</i>	Yes	Encryption capabilities: U for 128-bit, I for 40-bit, or N for no encryption.
<i>OS-or-CPU</i>	Yes	The operating system the browser is being run on or the processor type of the computer running the browser. If the platform is Windows, this is the version of Windows (such as WinNT, Win95, and so on). If the platform is Macintosh, then this is the CPU (either 68k, PPC for PowerPC, or MacIntel). If the Platform is X11, this is the Unix operating-system name as obtained by the Unix command <code>uname -sm</code> .

continues

(continued)

STRING	REQUIRED?	DESCRIPTION
<i>Language</i>	Yes	The language that the browser was created for use in.
<i>Prerelease Version</i>	No	Originally intended as the prerelease version number for Mozilla, it now indicates the version number of the Gecko rendering engine.
<i>GeckoVersion</i>	Yes	The version of the Gecko rendering engine represented by a date in the format <i>yyyymmdd</i> .
<i>ApplicationProduct</i>	No	The name of the product using Gecko. This may be Netscape, Firefox, and so on.
<i>ApplicationProductVersion</i>	No	The version of the <i>ApplicationProduct</i> ; this is separate from the <i>MozillaVersion</i> and the <i>GeckoVersion</i> .

To better understand the Gecko user-agent string format, consider the following user-agent strings taken from various Gecko-based browsers:

Netscape 6.21 on Windows XP:

```
Mozilla/5.0 (Windows; U; Windows NT 5.1; en-US; rv:0.9.4) Gecko/20011128
  Netscape6/6.2.1
```

SeaMonkey 1.1a on Linux:

```
Mozilla/5.0 (X11; U; Linux i686; en-US; rv:1.8.1b2) Gecko/20060823 SeaMonkey/1.1a
```

Firefox 2.0.0.11 on Windows XP:

```
Mozilla/5.0 (Windows; U; Windows NT 5.1; en-US; rv:1.8.1.11) Gecko/20071127
  Firefox/2.0.0.11
```

Camino 1.5.1 on Mac OS X:

```
Mozilla/5.0 (Macintosh; U; Intel Mac OS X; en; rv:1.8.1.6) Gecko/20070809
  Camino/1.5.1
```

All of these user-agent strings indicate Gecko-based browsers (albeit using different versions). Often-times, looking for a particular browser is not as important as understanding whether it's Gecko-based. The Mozilla version hasn't changed from 5.0 since the first Gecko-based browser was released, and it likely won't change again.

With the release of Firefox 4, Mozilla simplified the user-agent string. The major changes include:

- Removal of the Language token (i.e., "en-US" in the previous examples).
- The Encryption token is not present when the browser uses strong encryption (which is the default). That means there will no longer be a "U" in Mozilla user-agent strings, but "I" and "N" might still be present.

- The Platform token has been removed for Windows user-agent strings as "Windows" was redundant with the OS-or-CPU token, which always contained the string "Windows".
- The GeckoVersion token is now frozen to "Gecko/20100101".

An example of the final Firefox 4 user-agent string is:

```
Mozilla/5.0 (Windows NT 6.1; rv:2.0.1) Gecko/20100101 Firefox 4.0.1
```

WebKit

In 2003, Apple announced that it would release its own web browser, called Safari. The Safari rendering engine, called WebKit, began as a fork of the KHTML rendering engine used in the Linux-based Konqueror web browser. A couple of years later, WebKit was split off into its own open-source project, focusing on development of the rendering engine.

Developers of this new browser and rendering engine faced a problem similar to that faced by Internet Explorer 3: How do you ensure that the browser isn't locked out of popular sites? The answer is, put enough information into the user-agent string to convince websites that the browser is compatible with another popular browser. This led to a user-agent string with the following format:

```
Mozilla/5.0 (Platform; Encryption; OS-or-CPU; Language)
AppleWebKit/AppleWebKitVersion (KHTML, like Gecko) Safari/SafariVersion
```

Here's an example:

```
Mozilla/5.0 (Macintosh; U; PPC Mac OS X; en) AppleWebKit/124 (KHTML, like Gecko)
Safari/125.1
```

As you can see, this is another long user-agent string. It takes into account not only the version of the Apple WebKit but also the Safari version. A point of contention over whether to identify the browser as Mozilla was resolved rather quickly for compatibility reasons. Now, all WebKit-based browsers identify themselves as Mozilla 5.0, the same as all Gecko-based browsers. The Safari version has typically been the build number of the browser, not necessarily a representation of the release version number. Although Safari 1.25 has the number 125.1 in the user-agent string, there may not always be a one-to-one match.

The most interesting and controversial part of this user-agent string is the addition of the string "(KHTML, like Gecko)" in a pre-1.0 version of Safari. Apple got a lot of pushback from developers who saw this as a blatant attempt to trick clients and servers into thinking Safari was actually Gecko (as if adding Mozilla/5.0 wasn't enough). Apple's response was similar to Microsoft's when the Internet Explorer user-agent string came under fire: Safari is compatible with Mozilla, and websites shouldn't block out Safari users because they appear to be using an unsupported browser.

Safari's user-agent string was augmented slightly when version 3 was released. The following version token is now used to identify the actual version of Safari being used:

```
Mozilla/5.0 (Macintosh; U; PPC Mac OS X; en) AppleWebKit/522.15.5
(KHTML, like Gecko) Version/3.0.3 Safari/522.15.5
```

Note that this change was made only to Safari, not to WebKit, so other WebKit-based browsers may not have this change. Generally speaking, as with Gecko, it's typical to determine that a browser is WebKit-based rather than trying to identify Safari specifically.

Konqueror

Konqueror, the browser bundled with the KDE Linux desktop environment, is based on the KHTML open-source rendering engine. Though available only on Linux, Konqueror has an active user base. For optimal compatibility, Konqueror opted to format its user-agent string after Internet Explorer as follows:

```
Mozilla/5.0 (compatible; Konqueror/Version; OS-or-CPU)
```

However, Konqueror 3.2 introduced a change to coincide with changes to the WebKit user-agent string, identifying itself as KHTML, as follows:

```
Mozilla/5.0 (compatible; Konqueror/Version; OS-or-CPU) KHTML/KHTMLVersion  
(like Gecko)
```

Here's an example:

```
Mozilla/5.0 (compatible; Konqueror/3.5; SunOS) KHTML/3.5.0 (like Gecko)
```

The version numbers for Konqueror and KHTML tend to coincide or be within a subpoint difference, such as Konqueror 3.5 using KHTML 3.5.1.

Chrome

Google's Chrome web browser uses Blink as its rendering engine but uses V8 as its JavaScript engine. Chrome's user-agent string carries along all of the information from WebKit and an extra section for the Chrome version. The format is as follows:

```
Mozilla/5.0 (Platform; Encryption; OS-or-CPU; Language)  
AppleWebKit/AppleWebKitVersion (KHTML, like Gecko)  
Chrome/ChromeVersion Safari/SafariVersion
```

Following is the full user-agent string for Chrome 7:

```
Mozilla/5.0 (Windows; U; Windows NT 5.1; en-US) AppleWebKit/534.7  
(KHTML, like Gecko) Chrome/7.0.517.44 Safari/534.7
```

It's likely that the WebKit version and Safari version will always be synchronized going forward, though this is not guaranteed.

Opera

One of the most controversial web browsers, as far as user-agent strings are concerned, is Opera. The default user-agent string for Opera is the most logical of all modern browsers, correctly identifying itself and its version. Prior to version 8, the Opera user-agent string was in the following format:

```
Opera/Version (OS-or-CPU; Encryption) [Language]
```

Following is the user-agent string for Opera 7.54 on a Windows XP computer:

```
Opera/7.54 (Windows NT 5.1; U) [en]
```

With the release of Opera 8, the language part of the user-agent string was moved inside of the parentheses to better match other browsers, as follows:

```
Opera/Version (OS-or-CPU; Encryption; Language)
```

Opera 8 on Windows XP yields the following user-agent string:

```
Opera/8.0 (Windows NT 5.1; U; en)
```

By default, Opera returns a user-agent string in this simple format. It was the only one of the major browsers to use the product name and version to fully and completely identify itself. As with other browsers, however, Opera found problems with using its own user-agent string. Even though it's technically correct, there is a lot of browser-sniffing code on the Internet that is geared toward user-agent strings reporting the Mozilla product name. There is also a fair amount of code looking specifically for Internet Explorer or Gecko. Instead of confusing sniffers by changing its own user-agent string, Opera identifies itself as a different browser completely by changing its own user-agent string.

Beginning with the release of Opera 9, there are two ways to change the user-agent string. One way is to identify it as another browser, either Firefox or Internet Explorer. When using this option, the user-agent string changes to look just like the corresponding user-agent for Firefox or Internet Explorer, with the addition of the string "Opera" and Opera's version number at the end. Here's an example:

```
Mozilla/5.0 (Windows NT 5.1; U; en; rv:1.8.1) Gecko/20061208 Firefox/2.0.0  
Opera 9.50
```

```
Mozilla/4.0 (compatible; MSIE 6.0; Windows NT 5.1; en) Opera 9.50
```

The first string identifies Opera 9.5 as Firefox 2 while maintaining the Opera version information. The second string identifies Opera 9.5 as Internet Explorer 6 and includes the Opera version information. Although these user-agent strings pass most tests for Firefox and Internet Explorer, the possibility of identifying Opera is open.

Another option for identifying the browser is to mask it as either Firefox or Internet Explorer. When masking the browser's identity, the user-agent strings are exactly the same as would be returned from the other browsers—the string "Opera" does not appear, nor does any Opera version information. There is literally no way to distinguish Opera from the other browsers when identity masking is used. Further complicating the issue is Opera's tendency to set site-specific user-agent strings without notifying the user. For instance, navigating to the My Yahoo! site (<http://my.yahoo.com>) automatically causes Opera to mask itself as Firefox. This makes identifying Opera by user-agent string very difficult.

NOTE Before version 7, Opera could interpret the meaning of Windows operating-system strings. For example, Windows NT 5.1 actually means Windows XP, so in Opera 6, the user-agent string included Windows XP instead of Windows NT 5.1. In an effort to be more compatible with other browsers, version 7 and above began to include the officially reported operating-system version instead of an interpreted one.

Opera 10 introduced changes to its user-agent string. The format became:

```
Opera/9.80 (OS-or-CPU; Encryption; Language) Presto/PrestoVersion Version/Version
```

Note that the initial version, Opera/9.80, remains fixed. There was no Opera 9.8, but Opera engineers were afraid that poor browser sniffing might cause a token of Opera/10.0 to be incorrectly interpreted as Opera 1 instead of Opera 10. Thus, Opera 10 introduced the additional Presto token (Presto is the rendering engine for Opera) and the Version token to hold the actual browser version. This is the user-agent string for Opera 10.63 on Windows 7:

```
Opera/9.80 (Windows NT 6.1; U; en) Presto/2.6.30 Version/10.63
```

Modern versions of Opera have transitioned to using an OPR identifier inside the user-agent appended to a more standardized user-agent string. Lexically, the user-agent now resembles that of WebKit browsers with the exception of the trailing OPR clause. This is the user-agent string for Opera 52 on Windows 10:

```
Mozilla/5.0 (Windows NT 10.0; Win64; x64) AppleWebKit/537.36 (KHTML, like Gecko)
Chrome/65.0.3325.181 Safari/537.36 OPR/52.0.2871.64
```

iOS and Android

The default web browsers for both iOS and Android mobile operating systems are based on WebKit and so share the same basic user-agent string format as their desktop counterparts. iOS devices follow this basic format:

```
Mozilla/5.0 (Platform; Encryption; OS-or-CPU like Mac OS X; Language)
AppleWebKit/AppleWebKitVersion (KHTML, like Gecko) Version/BrowserVersion
Mobile/MobileVersion Safari/SafariVersion
```

Note the addition of "like Mac OS X" to aid in detecting Mac operating systems and the addition of a Mobile token. The Mobile token version number is typically not useful and is used primarily to determine a mobile WebKit versus a desktop one. The platform will be "iPhone", "iPod", or "iPad", depending on the device. For example:

```
Mozilla/5.0 (iPhone; U; CPU iPhone OS 3_0 like Mac OS X; en-us)
AppleWebKit/528.18 (KHTML, like Gecko) Version/4.0 Mobile/7A341 Safari/528.16
```

Note that prior to iOS 3, the version number of the operating system did not appear in the user-agent string.

The default Android browser generally follows the format set forth on iOS but without a Mobile version (the Mobile token is still present). For example:

```
Mozilla/5.0 (Linux; U; Android 2.2; en-us; Nexus One Build/FRF91)
AppleWebKit/533.1 (KHTML, like Gecko) Version/4.0 Mobile Safari/533.1
```

This user-agent string is from a Google Nexus One phone, but other Android devices follow the same pattern.

Using User-Agent for Browser Analysis

Most developers looking to identify which browser their code is running inside would consider analyzing the string returned from `window.navigator.userAgent` as the canonical strategy for doing so. All browsers offer such a string, and if you trust the value returned, checking the user-agent

against a known catalogue can yield an exceptionally accurate picture of the browser and operating system.

The advantage of using user-agent over capability detection over user-agents to identify a browser is that, while capability detection offers more robust protection against scripts that might work to conceal the browser, user-agents of modern browsers are organized in a predictable fashion for past, current, and future versions of a vendor's browser.

Spoofing a User-Agent

User-agent identification is an imperfect browser identification solution, especially because of how easy it is to spoof a user-agent string. Browsers that properly implement the `window.navigator` object (effectively all of them) will offer it as a read-only property. Therefore, using the setter does nothing:

```
console.log(window.navigator.userAgent);
// Mozilla/5.0 (Windows NT 10.0; Win64; x64) AppleWebKit/537.36 (KHTML, like Gecko)
Chrome/65.0.3325.181 Safari/537.36

window.navigator.userAgent = 'foobar';

console.log(window.navigator.userAgent);
// Mozilla/5.0 (Windows NT 10.0; Win64; x64) AppleWebKit/537.36 (KHTML, like Gecko)
Chrome/65.0.3325.181 Safari/537.36
```

However, there are a number of trivial workarounds for this. For example, browsers that offer the pseudo-private `__defineGetter__` make spoofing the user-agent very easy:

```
console.log(window.navigator.userAgent);
// Mozilla/5.0 (Windows NT 10.0; Win64; x64) AppleWebKit/537.36 (KHTML, like Gecko)
Chrome/65.0.3325.181 Safari/537.36

window.navigator.__defineGetter__('userAgent', () => 'foobar');

console.log(window.navigator.userAgent);
// foobar
```

Mitigating workarounds like these is an uphill battle. Detecting if the user-agent has been spoofed in such a manner is possible but doing so in a robust manner is essentially a game of whack-a-mole.

Instead of resorting to spoof detection, prefer to select a philosophy surrounding browser identification. If you trust the user-agent returned to you, use that to derive identity. If you suspect a script or browser may be manipulating this value, you may prefer to use capability detection.

Using User-Agents for Browser Analysis

By parsing the user-agent of the browser, you can reliably infer many of the following details about the environment with excellent accuracy:

- Browser
- Browser version
- Browser rendering engine

- Device class (desktop/mobile)
- Device manufacturer
- Device model
- Operating system
- Operating system version

There are new browsers, operating systems, and devices coming out all the time, many with similar yet unique user-agent strings; as a result, user-agent parser implementations require constant updates to avoid becoming outdated. Any hand-rolled user-agent parser implementation will become quickly obsolete without constant updating and revision. Although the previous edition of this book built out its own version of a user-agent parser, constructing a parser from scratch is no longer recommended. Instead, the following are a few user-agent parsers that are actively maintained:

- **Browser**—<https://github.com/lancedikson/browser>
- **ua-parser-js**—<https://github.com/faisalman/ua-parser-js>
- **Platform.js**—<https://github.com/bestiejs/platform.js>
- **current-device**—<https://github.com/matthewhudson/current-device>
- **Google Closure**—<https://github.com/google/closure-library/tree/master/closure/goog/useragent>
- **Mootools**—<https://github.com/mootools/mootools-core/blob/master/Source/Browser/Browser.js>

NOTE *The Mozilla wiki offers a page of user-agent parsers that are able to identify Mozilla browsers (and, presumably, all major browsers). They are grouped by language and can be found at https://wiki.mozilla.org/Compatibility/UADetectionLibraries#JavaScript_2. The page is not actively maintained, but the list still offers all the major user-agent parsing libraries. (Note that the JavaScript section includes both client-side libraries and NodeJS libraries.) A table to visualize these can be found at <http://miketaylr.github.io/arewedetectableyet/>.*

SOFTWARE AND HARDWARE DETECTION

Modern browsers offer a suite of information about the page's execution environment, which includes browser information, operating system, hardware, and system peripherals. This information can be accessed through a collection of APIs that are found on the `window.navigator` object. However, the support across browsers for these APIs is far from standardized, and so support should be considered spotty at best.

NOTE *It is strongly recommended that you investigate browser support for any of these features before using them, as the majority are non-normative and unsupported on many browsers. Furthermore, the features covered here can be unreliable in some cases.*

Browser and Operating System Identification

Although feature detection and user-agent parsing are two ways of identifying the browser that is currently in use, the `navigator` and `screen` objects also offer information about the software environment in which the page is currently executing.

The `navigator.oscpu` Property

The `oscpu` property can provide a string, which is usually the operating system/architecture component of the user-agent. Per the HTML Living Standard:

The `oscpu` attribute's getter must return either the empty string or a string representing the platform on which the browser is executing—for example, "Windows NT 10.0; Win64; x64," "Linux x86_64."

For example, in Firefox on Windows 10, the `oscpu` property is reported as follows:

```
console.log(navigator.userAgent);
"Mozilla/5.0 (Windows NT 10.0; Win64; x64; rv:58.0) Gecko/20100101 Firefox/58.0"
console.log(navigator.oscpu);
"Windows NT 10.0; Win64; x64"
```

The `navigator.vendor` Property

The `vendor` property can provide a string, which is usually the browser vendor. The string returned is a function of the browser's navigator compatibility mode. Per the HTML Living Standard:

`navigator.vendor` returns either the empty string, the string "Apple Computer, Inc.," or the string "Google Inc."

For example, in Chrome, the `vendor` property is reported as follows:

```
console.log(navigator.vendor); // "Google Inc."
```

The `navigator.platform` Property

The `platform` property can provide a string, which is usually indicative of the operating system inside which the browser is executing. Per the HTML Living Standard:

`navigator.platform` must return either the empty string or a string representing the platform on which the browser is executing, e.g., "MacIntel," "Win32," "FreeBSD i386," "WebTV OS."

For example, in Chrome, the `platform` property is reported as follows:

```
console.log(navigator.platform); // "Win32"
```

The `screen.colorDepth` and `screen.pixelDepth` Properties

The `colorDepth` and `pixelDepth` properties return the same value: the number of color bits that can be represented in the display. Per the CSSOM Specification:

The `colorDepth` and `pixelDepth` attributes should return the number of bits allocated to colors for a pixel in the output device, excluding the alpha channel.

For example, in Chrome, these properties are reported as follows:

```
console.log(screen.colorDepth); // 24
console.log(screen.pixelDepth); // 24
```

The `screen.orientation` Property

The `orientation` property returns a `ScreenOrientation` object, which contains information about the browser's screen according to the Screen Orientation API. The most interesting properties inside this object are `angle`, which returns the angle of the screen relative to the default, and `type`, which returns a string from an enum of possible orientation types:

```
portrait-primary
portrait-secondary
landscape-primary
landscape-secondary
```

For example, in Chrome on a mobile phone, `screen.orientation` is reported as follows:

```
// Viewed vertically
console.log(screen.orientation.type); // portrait-primary
console.log(screen.orientation.angle); // 0

// Rotate phone left
console.log(screen.orientation.type); // landscape-primary
console.log(screen.orientation.angle); // 90

// Rotate phone right
console.log(screen.orientation.type); // landscape-secondary
console.log(screen.orientation.angle); // 270
```

Per the specification, the initialization of these values is subject to the browser and device so it cannot be assumed that `portrait-primary` and `0` will always be the initial values. These are best used to assess relative transformations of the browser orientation as the device is rotated.

Browser Metadata

The `navigator` object exposes a handful of APIs that can provide stateful information about the browser and operating system.

The Geolocation API

The `navigator.geolocation` property provides access to the Geolocation API, which allows browser scripts to learn about the current device's location. This API is only available in a secure execution context (scripts which are served via HTTPS).

The API can send out requests to the host system to return the device's location to the best of its ability. Depending on the hardware and configuration of the host system, the accuracy of the results may vary. A cell phone's GPS coordinates will have extremely high accuracy, whereas an IP address will have a much lower accuracy. Per the Geolocation API specification:

Common sources of location information include Global Positioning System (GPS) and location inferred from network signals such as IP address, RFID, WiFi and Bluetooth MAC addresses, and GSM/CDMA cell IDs, as well as user input.

NOTE *Browsers may also make use of tools such as Google Location Services (used by Chrome and Firefox) to determine your location. You will notice that, although your device does not have a GPS radio, the coordinates your browser returns will often be extremely accurate. The browser accomplishes this by collecting the identities of all visible wireless networks in range, both WiFi and cellular towers if possible. These are then checked against a database of networks whose locations are already known. In this manner, these services are able to pinpoint your device's location with exceptionally high accuracy.*

To perform a one-time capture of the browser's current location, use the `getCurrentPosition()` method. It returns a `Coordinates` object, the contents of which may or may not be complete depending on the abilities of the host system:

```
// getCurrentPosition() callback is invoked with Position object as only argument
let p;
navigator.geolocation.getCurrentPosition((position) => p = position);
```

The `Position` object contains a timestamp representing when the object's contents were obtained and a `Coordinates` object:

```
console.log(p.timestamp); // 1525364883361
console.log(p.coords); // Coordinates {...}
```

The `Coordinates` object contains latitude/longitude in standard degrees format, as well as the accuracy of that pair in meters. The accuracy measurement is provided by the same mechanism that assessed the device location.

```
console.log(p.coords.latitude, p.coords.longitude); // 37.4854409, -122.2325506
console.log(p.coords.accuracy); // 58
```

The `Coordinates` object contains an `altitude` property, which is defined by the measured distance in meters above the WGS84 (World Geodetic System, 1984) ellipsoid model of Earth. The object also contains an `altitudeAccuracy` property, the accuracy of the measurement in meters. To be filled

inside a `Coordinates` object, these values will be directly provided by the device (which means it will need to have access to appropriate measurement hardware, likely a GPS radio or altimeter). Many devices are incapable of measuring altitude, and so one or both of these values are frequently null.

```
console.log(p.coords.altitude); // -8.800000190734863
console.log(p.coords.altitudeAccuracy); // 200
```

NOTE *More information about the WGS84 model can be found at <http://earth-info.nga.mil/GandG/publications/tr8350.2/wgs84fin.pdf>.*

The `Coordinates` object contains a `speed` property, which is defined by the measured speed of the device in meters per second. The object also contains a `heading` property, which is defined by the direction of travel relative to true north in degrees ($0 \leq \text{heading} < 360$). To be filled inside a `Coordinates` object, these values will be directly provided by the device (which means it will need to have access to appropriate measurement hardware, likely an accelerometer and compass). Many devices are incapable of measuring speed and heading, so these values are frequently null.

NOTE *Devices will not attempt to measure speed and heading using a derived vector of two location measurements. It is possible, however, to manually calculate these values by performing two consecutive measurements and deriving a direction of travel vector. Of course, depending on the accuracy of the two location measurements, the speed and heading you derive may be highly inaccurate!*

Capturing a browser's location is a best-effort operation, and there are a number of reasons the capture could fail. The `getCurrentPosition()` method accepts the failure callback as a second argument, and this method is passed a `PositionError` object. In the event of a failure, this object will contain a `code` property, and a `message` property with a short description of the error. The `code` property will be an integer indicating one of three possible errors:

- **PERMISSION_DENIED**—The browser was blocked from accessing the device's location. The first time a page attempts to use the Geolocation API, the browser will prompt the user to allow access (this occurs on a per-domain basis). If this error code is encountered, either the user has denied access to the device's location, or the Geolocation API is being accessed from a non-secure context. The `message` property can offer additional information.
- **POSITION_UNAVAILABLE**—The system was unable to return any location information. This can represent any number of possible points of failure but will be a relatively uncommon error since a networked device can usually resolve an IP address to a low-accuracy coordinate.

- **TIMEOUT**—The system was unable to return location information within the timeout period. Configuring the timeout period is discussed in the material that follows.

```
// Browsers will prompt the user to allow access to the Geolocation API.
// This example shows what occurs when the user denies access.
navigator.geolocation.getCurrentPosition(
  () => {},
  (e) => {
    console.log(e.code); // 1
    console.log(e.message); // User denied Geolocation
  }
);

// This example shows what occurs when executing in an insecure context.
navigator.geolocation.getCurrentPosition(
  () => {},
  (e) => {
    console.log(e.code); // 1
    console.log(e.message); // Only secure origins are allowed
  }
);
```

Geolocation API location requests can be configured using a `PositionOptions` object, which is provided as the third argument. This object supports three properties:

- **enableHighAccuracy**—A Boolean indicating to the system that, when `true`, the value returned should be as accurate as possible; the default value of the flag is `false`. By default, devices will usually choose to return coordinates in the quickest and most energy-efficient manner possible. This will often mean coordinates are less accurate. For example, on mobile devices, the default location lookup normally takes the form of deriving the device location from only WiFi and cell networks. When `enableHighAccuracy` is `true`, it will also request that the device use the GPS radio to determine the device location, and the returned coordinates will be a hybrid result of these values. Using the GPS radio is a slower and more battery-intensive operation, so weigh the tradeoffs of using the `enableHighAccuracy` flag.
- **timeout**—A number indicating the maximum number of milliseconds the API call should wait before invoking the error callback with the `TIMEOUT` status; the default value is `0xFFFFFFFF (232 - 1)`. A value of `0` will skip the system call entirely and immediately invoke the `TIMEOUT` error callback.
- **maximumAge**—A number indicating the maximum age of the returned coordinates in milliseconds; the default value is `0`. Because determining a device's location is an expensive operation, systems will often cache coordinates and return the cached value (subject to its location cache expiration policy). The system tracks how old the cached value is, and if the Geolocation API requests coordinates that must be newer than the cached value, the system will perform a fresh location lookup and return that value. A value of `0` will force the system to ignore any cached value and perform a fresh location lookup. A value of `Infinity` will prevent the system from performing a fresh lookup and only use cached values. JavaScript can determine if a cached value is returned by checking for duplicate `timestamp` properties inside the `Position` object.

Connection State and the NetworkInformation API

The browser tracks the network connection state and exposes this information in two ways: connection events, and the `navigator.onLine` property. When the device connects to a network, the browser will become aware of this fact and fire an `online` event on the `window` object. In turn, when the device loses a network connection, the browser will fire an `offline` event on the `window` object. At any time, the current browser state can be determined by inspecting the `navigator.onLine` property, which contains a Boolean indicating if the browser is connected.

```
const connectionStateChange = () => console.log(navigator.onLine);

window.addEventListener('online', connectionStateChange);
window.addEventListener('offline', connectionStateChange);

// On device connect:
// true

// On device disconnect:
// false
```

Of course, what determines a network connection is subject to the browser and system implementation. Some browsers will consider a connection to any local area network as "online," even though that network might not have proper Internet access.

Also exposed on the `navigator` object is the NetworkInformation API, which can be found under the `navigator.connection` property. This API offers a handful of read-only properties as well as an event source for attaching callbacks when connection properties change.

The following properties are available:

- `downlink`—An integer indicating the current bandwidth of the device in Mbps, rounded to the nearest 25 Kbps. This calculation may be derived from historical network throughput measurements or the capabilities of the connection technology.
- `downlinkMax`—An integer indicating the current maximum downlink bandwidth in Mbps as determined by the first network hop. Because the first network hop is not necessarily indicative of end-to-end network performance, this value should only be used as a rough upper bound.
- `effectiveType`—A string enum indicating the general connection speed and quality. The values are designated as cellular data network connections, but these are used to classify wired connections as well. The property will have one of four values:
 - `"slow-2g"`
 - Roundtrip time >2000 ms
 - Downlink bandwidth < 50 Kbps.
 - `"2g"`
 - 2000 ms > roundtrip time ≥ 1400 ms
 - 70 Kbps > downlink bandwidth ≥ 50 Kbps.

- "3g"
 - 1400 ms > roundtrip time \geq 270 ms
 - 700 Kbps > downlink bandwidth \geq 70 Kbps.
- "4g"
 - 270 ms > roundtrip time \geq 0 ms
 - Downlink bandwidth \geq 700 Kbps.
- `rtt`—An integer indicating the current effective network request roundtrip time in milliseconds, rounded to the nearest 25 ms. This calculation may be derived from historical network throughput measurements or the capabilities of the connection technology.
- `type`—A string enum indicating the network connection technology. The property will have one of the following values:
 - `bluetooth`—Indicates a Bluetooth connection.
 - `cellular`—Indicates a cellular network.
 - `ethernet`—Indicates a wired Ethernet connection.
 - `none`—Indicates no network connection. Equivalent to `navigator.onLine === false`.
 - `mixed`—Indicates multiple simultaneous connection types.
 - `other`—Indicates a connection type that is not listed as a valid value in this enum.
 - `unknown`—Indicates a connection type that cannot be determined.
 - `wifi`—Indicates a WiFi connection.
 - `wimax`—Indicates a WiMAX connection.
- `saveData`—A Boolean indicating if the user has enabled the "reduced data mode" on his or her device.
- `onchange`—The property that will emit a change event when any connection status changes. This can be used either via `navigator.connection.addEventListener('change', changeHandler)` or `navigator.connection.onchange = changeHandler`.

Battery Status API

The browser is capable of accessing information about the device's battery and charging state. The `navigator.getBattery()` method returns a promise that resolves to a `BatteryManager` object.

```
navigator.getBattery().then((b) => console.log(b));
// BatteryManager { ... }
```

The `BatteryManager` offers four read-only properties that provide information about the device's battery:

- `charging`—A Boolean indicating if the device is currently plugged in and charging. If the device has no battery, returns `true`.

- `chargingTime`—An integer indicating the estimated number of seconds until the battery is fully charged. Returns 0 if the battery is fully charged or if the device has no battery.
- `dischargingTime`—An integer indicating the estimated number of seconds until the battery is fully depleted. Returns `Infinity` if the device has no battery.
- `level`—A floating point number indicating the fractional charge of the battery. Returns 0.0 to indicate a fully discharged battery, 1.0 to indicate a fully charged battery. Returns 1.0 if the device has no battery.

The API also offers four event properties that can be used to set callbacks when any of the battery properties change. This can be accomplished either by adding an event listener on the `BatteryManager` object or assigning the handler to the respective property:

- `onchargingchange`
- `onchargingtimechange`
- `ondischargingtimechange`
- `onlevelchange`

```
navigator.getBattery().then((battery) => {  
  // Assign callback for when the charging state changes:  
  const chargingChangeHandler = () => console.log('chargingchange');  
  battery.onchargingchange = chargingChangeHandler;  
  // OR  
  battery.addEventListener('chargingchange', chargingChangeHandler);  
  
  // Assign callback for when the charging time changes:  
  const chargingTimeChangeHandler = () => console.log('chargingtimechange');  
  battery.onchargingtimechange = chargingTimeChangeHandler;  
  // OR  
  battery.addEventListener('chargingtimechange', chargingTimeChangeHandler);  
  
  // Assign callback for when the discharging time changes:  
  const dischargingChangeHandler = () => console.log('dischargingtimechange');  
  battery.ondischargingtimechange = dischargingTimeChangeHandler;  
  // OR  
  battery.addEventListener('dischargingtimechange', dischargingTimeChangeHandler);  
  
  // Assign callback for when the battery level changes:  
  const levelChangeHandler = () => console.log('levelchange');  
  battery.onlevelchange = levelChangeHandler;  
  // OR  
  battery.addEventListener('levelchange', levelChangeHandler);  
});
```

Hardware

The ability of the browser to detect the system hardware is quite limited; however, a number of properties on the `navigator` object can provide basic information.

Processor Cores

It is possible to determine the number of logical processor cores that the browser supports via the `navigator.hardwareConcurrency` property, which contains an integer representing the number of supported cores (or 1 if a determination cannot be made). Importantly, this value indicates the maximum number of concurrent workers that the browser is capable of executing in parallel, and not necessarily the number of actual cores the CPU features.

Device Memory

It is possible to determine the approximate amount of system memory on the device via the `navigator.deviceMemory` property, which contains a float representing the number of gigabytes of memory on the device rounded to the nearest power of 2: 512MB would return 0.5; 4GB would return 4.

Maximum Touch Points

It is possible to determine the maximum number of touch contacts supported on a touchscreen via the `navigator.maxTouchPoints` property, which is defined as an integer.

SUMMARY

Client detection is one of the most controversial topics in JavaScript. Because of differences in browsers, it is often necessary to fork code based on the browser's capabilities. There are several approaches to client detection, but the following two are used most frequently:

- **Capability detection**—Tests for specific browser capabilities before using them. For instance, a script may check to see if a function exists before calling it. This approach frees developers from worrying about specific browser types and versions, enabling them to focus on whether the capability exists or not. Capabilities detection cannot accurately detect a specific browser or version.
- **User-agent detection**—Identifies the browser by looking at its user-agent string. The user-agent string contains a great deal of information about the browser, often including the browser, platform, operating system, and browser version. There is a long history to the development of the user-agent string, with browser vendors attempting to fool websites into believing they are another browser. User-agent detection can be tricky, especially when dealing with Opera's ability to mask its user-agent string. Even so, the user-agent string can determine the rendering engine being used and the platform on which it runs, including mobile devices and gaming systems.

When you are deciding which client-detection method to use, it's preferable to use capability detection first. Quirks detection is the second choice for determining how your code should proceed. User-agent detection is considered the last choice for client detection because it is so dependent on the user-agent string.

Browsers also offer an increasingly broad picture of the software and hardware surrounding it. Through the `screen` and `navigator` objects, it is possible to derive an extremely accurate idea of the operating system, browser, hardware, device location, battery status, and a wide variety of other topics.

14

The Document Object Model

WHAT'S IN THIS CHAPTER?

- Understanding the DOM as a hierarchy of nodes
- Working with the various node types
- Coding the DOM around browser incompatibilities and gotchas
- Mutation Observers

WROX.COM DOWNLOADS FOR THIS CHAPTER

Please note that all the code examples for this chapter are available as a part of this chapter's code download on the book's website at www.wrox.com/go/projavascript4e on the Download Code tab.

The Document Object Model (DOM) is an application programming interface (API) for HTML and XML documents. The DOM represents a document as a hierarchical tree of nodes, allowing developers to add, remove, and modify individual parts of the page. Evolving out of early Dynamic HTML (DHTML) innovations from Netscape and Microsoft, the DOM is now a truly cross-platform, language-independent way of representing and manipulating pages for markup.

DOM Level 1 became a W3C recommendation in October 1998, providing interfaces for basic document structure and querying. This chapter focuses on the features and uses of the DOM as it relates to HTML pages in the browser and the DOM JavaScript API.

NOTE *Note that all DOM objects are represented by COM objects in Internet Explorer 8 and earlier. This means that the objects don't behave or function the same way as native JavaScript objects.*

HIERARCHY OF NODES

Any HTML or XML document can be represented as a hierarchy of nodes using the DOM. There are several node types, each representing different information and/or markup in the document. Each node type has different characteristics, data, and methods, and each may have relationships with other nodes. These relationships create a hierarchy that allows markup to be represented as a tree, rooted at a particular node. For instance, consider the following HTML:

```
<html>
  <head>
    <title>Sample Page</title>
  </head>
  <body>
    <p>Hello World!</p>
  </body>
</html>
```

This simple HTML document can be represented in a hierarchy, as illustrated in Figure 14-1.

A document node represents every document as the root. In this example, the only child of the document node is the `<html>` element, which is called the *document element*. The document element is the outermost element in the document within which all other elements exist. There can be only one document element per document. In HTML pages, the document element is always the `<html>` element. In XML, where there are no predefined elements, any element may be the document element.

Every piece of markup can be represented by a node in the tree: HTML elements are represented by element nodes, attributes are represented by attribute nodes, the document type is represented by a document type node, and comments are represented by comment nodes. In total, there are 12 node types, all of which inherit from a base type.

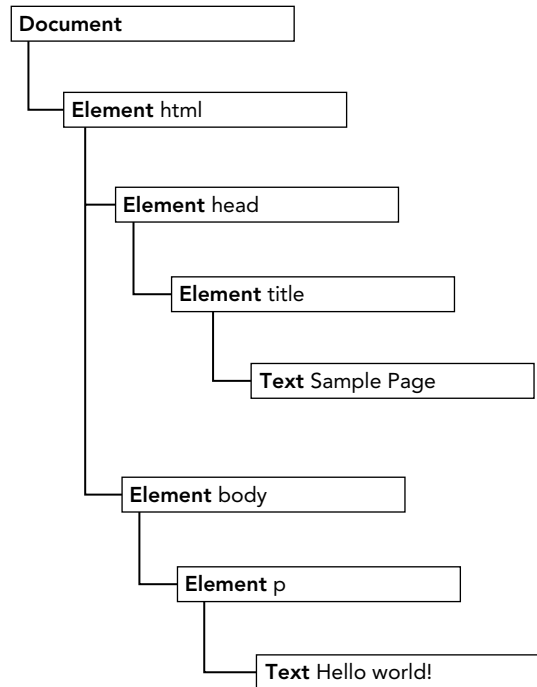

FIGURE 14-1:

The Node Type

DOM Level 1 describes an interface called `Node` that is to be implemented by all node types in the DOM. The `Node` interface is implemented in JavaScript as the `Node` type, which is accessible in all browsers except Internet Explorer. All node types inherit from `Node` in JavaScript, so all node types share the same basic properties and methods.

Every node has a `nodeType` property that indicates the type of node that it is. Node types are represented by one of the following 12 numeric constants on the `Node` type:

- `Node.ELEMENT_NODE` (1)
- `Node.ATTRIBUTE_NODE` (2)
- `Node.TEXT_NODE` (3)
- `Node.CDATA_SECTION_NODE` (4)
- `Node.ENTITY_REFERENCE_NODE` (5)
- `Node.ENTITY_NODE` (6)
- `Node.PROCESSING_INSTRUCTION_NODE` (7)
- `Node.COMMENT_NODE` (8)
- `Node.DOCUMENT_NODE` (9)
- `Node.DOCUMENT_TYPE_NODE` (10)
- `Node.DOCUMENT_FRAGMENT_NODE` (11)
- `Node.NOTATION_NODE` (12)

A node's type is easy to determine by comparing against one of these constants, as shown here:

```
if (someNode.nodeType == Node.ELEMENT_NODE) {
    alert("Node is an element.");
}
```

This example compares the `someNode.nodeType` to the `Node.ELEMENT_NODE` constant. If they're equal, it means `someNode` is actually an element.

Not all node types are supported in web browsers. Developers most often work with element and text nodes. The support level and usage of each node type is discussed later in the chapter.

The `nodeName` and `nodeValue` Properties

Two properties, `nodeName` and `nodeValue`, give specific information about the node. The values of these properties are completely dependent on the node type. It's always best to test the node type before using one of these values, as the following code shows:

```
if (someNode.nodeType == 1) {
    value = someNode.nodeName;    // will be the element's tag name
}
```

In this example, the node type is checked to see if the node is an element. If so, the `nodeName` value is assigned to a variable. For elements, `nodeName` is always equal to the element's tag name, and `nodeValue` is always `null`.

Node Relationships

All nodes in a document have relationships to other nodes. These relationships are described in terms of traditional family relationships as if the document tree were a family tree. In HTML, the `<body>` element is considered a child of the `<html>` element; likewise the `<html>` element is considered the parent of the `<body>` element. The `<head>` element is considered a sibling of the `<body>` element, because they both share the same immediate parent, the `<html>` element.

Each node has a `childNodes` property containing a `NodeList`. A `NodeList` is an array-like object used to store an ordered list of nodes that are accessible by position. Keep in mind that a `NodeList` is not an instance of `Array` even though its values can be accessed using bracket notation and the `length` property is present. `NodeList` objects are unique in that they are actually queries being run against the DOM structure, so changes will be reflected in `NodeList` objects automatically. It is often said that a `NodeList` is a living, breathing object rather than a snapshot of what happened at the time it was first accessed.

The following example shows how nodes stored in a `NodeList` may be accessed via bracket notation or by using the `item()` method:

```
let firstChild = someNode.childNodes[0];
let secondChild = someNode.childNodes.item(1);
let count = someNode.childNodes.length;
```

Note that using bracket notation and using the `item()` method are both acceptable practices, although most developers use bracket notation because of its similarity to arrays. Also note that the `length` property indicates the number of nodes in the `NodeList` at that time. It's possible to convert `NodeList` objects into arrays using `Array.prototype.slice()` as was discussed earlier for the arguments object. Consider the following example:

```
let arrayOfNodes = Array.prototype.slice.call(someNode.childNodes, 0);
```

Each node has a `parentNode` property pointing to its parent in the document tree. All nodes contained within a `childNodes` list have the same parent, so each of their `parentNode` properties points to the same node. Additionally, each node within a `childNodes` list is considered to be a sibling of the other nodes in the same list. It's possible to navigate from one node in the list to another by using the `previousSibling` and `nextSibling` properties. The first node in the list has `null` for the value of its `previousSibling` property, and the last node in the list has `null` for the value of its `nextSibling` property, as shown in the following example:

```
if (someNode.nextSibling === null){
  alert("Last node in the parent's childNodes list.");
} else if (someNode.previousSibling === null){
  alert("First node in the parent's childNodes list.");
}
```

Note that if there's only one child node, both `nextSibling` and `previousSibling` will be `null`.

Another relationship exists between a parent node and its first and last child nodes. The `firstChild` and `lastChild` properties point to the first and last node in the `childNodes` list, respectively. The value of `someNode.firstChild` is always equal to `someNode.childNodes[0]`, and the value of `someNode.lastChild` is always equal to `someNode.childNodes[someNode.childNodes.length-1]`. If there is only one child node, `firstChild` and `lastChild` point to the same node; if there are no children, then `firstChild` and `lastChild` are both `null`. All of these relationships help to navigate easily between nodes in a document structure. Figure 14-2 illustrates these relationships.

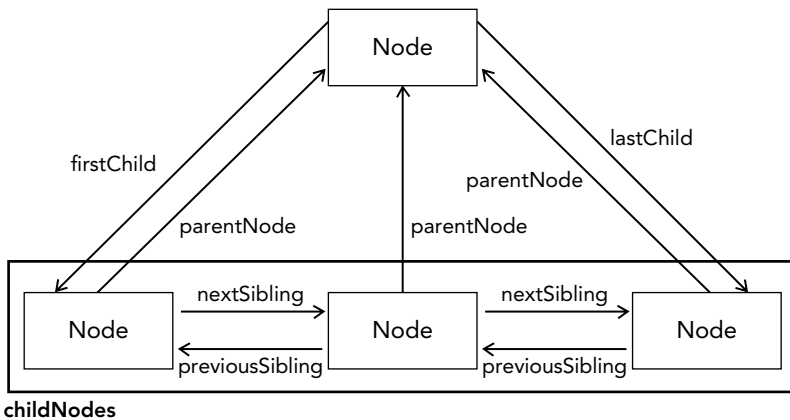

FIGURE 14-2:

With all of these relationships, the `childNodes` property is really more of a convenience than a necessity because it's possible to reach any node in a document tree by simply using the relationship pointers. Another convenience method is `hasChildNodes()`, which returns `true` if the node has one or more child nodes and is more efficient than querying the `length` of the `childNodes` list.

One final relationship is shared by every node. The `ownerDocument` property is a pointer to the document node that represents the entire document. Nodes are considered to be owned by the document in which they were created (typically the same in which they reside), because nodes cannot exist simultaneously in two or more documents. This property provides a quick way to access the document node without needing to traverse the node hierarchy back up to the top.

NOTE *Not all node types can have child nodes even though all node types inherit from `Node`. The differences among node types are discussed later in this chapter.*

Manipulating Nodes

Because all relationship pointers are read-only, several methods are available to manipulate nodes. The most-often-used method is `appendChild()`, which adds a node to the end of the `childNodes` list. Doing so updates all of the relationship pointers in the newly added node, the parent node, and the previous last child in the `childNodes` list. When complete, `appendChild()` returns the newly added node. Here is an example:

```
let returnedNode = someNode.appendChild(newNode);
alert(returnedNode == newNode);           // true
alert(someNode.lastChild == newNode);     // true
```

If the node passed into `appendChild()` is already part of the document, it is removed from its previous location and placed at the new location. Even though the DOM tree is connected by a series of pointers, no DOM node may exist in more than one location in a document. So if you call

`appendChild()` and pass in the first child of a parent, as the following example shows, it will end up as the last child:

```
// assume multiple children for someNode
let returnedNode = someNode.appendChild(someNode.firstChild);
alert(returnedNode == someNode.firstChild); // false
alert(returnedNode == someNode.lastChild); // true
```

When a node needs to be placed in a specific location within the `childNodes` list, instead of just at the end, the `insertBefore()` method may be used. The `insertBefore()` method accepts two arguments: the node to insert and a reference node. The node to insert becomes the previous sibling of the reference node and is ultimately returned by the method. If the reference node is null, then `insertBefore()` acts the same as `appendChild()`, as this example shows:

```
// insert as last child
returnedNode = someNode.insertBefore(newNode, null);
alert(newNode == someNode.lastChild); // true

// insert as the new first child
returnedNode = someNode.insertBefore(newNode, someNode.firstChild);
alert(returnedNode == newNode); // true
alert(newNode == someNode.firstChild); // true

// insert before last child
returnedNode = someNode.insertBefore(newNode, someNode.lastChild);
alert(newNode == someNode.childNodes[someNode.childNodes.length - 2]); // true
```

Both `appendChild()` and `insertBefore()` insert nodes without removing any. The `replaceChild()` method accepts two arguments: the node to insert and the node to replace. The node to replace is returned by the function and is removed from the document tree completely while the inserted node takes its place. Here is an example:

```
// replace first child
let returnedNode = someNode.replaceChild(newNode, someNode.firstChild);

// replace last child
returnedNode = someNode.replaceChild(newNode, someNode.lastChild);
```

When a node is inserted using `replaceChild()`, all of its relationship pointers are duplicated from the node it is replacing. Even though the replaced node is technically still owned by the same document, it no longer has a specific location in the document.

To remove a node without replacing it, you can use the `removeChild()` method. This method accepts a single argument, which is the node to remove. The removed node is then returned as the function value, as this example shows:

```
// remove first child
let formerFirstChild = someNode.removeChild(someNode.firstChild);

// remove last child
let formerLastChild = someNode.removeChild(someNode.lastChild);
```

As with `replaceChild()`, a node removed via `removeChild()` is still owned by the document but doesn't have a specific location in the document.

All four of these methods work on the immediate children of a specific node, meaning that to use them you must know the immediate parent node (which is accessible via the previously mentioned `parentNode` property). Not all node types can have child nodes, and these methods will throw errors if you attempt to use them on nodes that don't support children.

Other Methods

Two other methods are shared by all node types. The first is `cloneNode()`, which creates an exact clone of the node on which it's called. The `cloneNode()` method accepts a single Boolean argument indicating whether to do a deep copy. When the argument is `true`, a deep copy is used, cloning the node and its entire subtree; when `false`, only the initial node is cloned. The cloned node that is returned is owned by the document but has no parent node assigned. As such, the cloned node is an orphan and doesn't exist in the document until added via `appendChild()`, `insertBefore()`, or `replaceChild()`. For example, consider the following HTML:

```
<ul>
  <li>item 1</li>
  <li>item 2</li>
  <li>item 3</li>
</ul>
```

If a reference to this `` element is stored in a variable named `myList`, the following code shows the two modes of the `cloneNode()` method:

```
let deepList = myList.cloneNode(true);
alert(deepList.childNodes.length);    // 3 (IE < 9) or 7 (others)

let shallowList = myList.cloneNode(false);
alert(shallowList.childNodes.length); // 0
```

In this example, `deepList` is filled with a deep copy of `myList`. This means `deepList` has three list items, each of which contains text. The variable `shallowList` contains a shallow copy of `myList`, so it has no child nodes. The difference in `deepList.childNodes.length` is due to the different ways that white space is handled in Internet Explorer 8 and earlier as compared to other browsers. Internet Explorer prior to version 9 did not create nodes for white space.

NOTE *The `cloneNode()` method doesn't copy JavaScript properties that you add to DOM nodes, such as event handlers. This method copies only attributes and, optionally, child nodes. Everything else is lost. Internet Explorer has a bug where event handlers are also cloned, so removing event handlers before cloning is recommended.*

The last remaining method is `normalize()`. Its sole job is to deal with text nodes in a document subtree. Because of parser implementations or DOM manipulations, it's possible to end up with text nodes that contain no text or text nodes that are siblings. When `normalize()` is called on a node, that node's descendants are searched for both of these circumstances. If an empty text node is found, it is removed; if text nodes are immediate siblings, they are joined into a single text node. This method is discussed further later on in this chapter.

The Document Type

JavaScript represents document nodes via the `Document` type. In browsers, the document object is an instance of `HTMLDocument` (which inherits from `Document`) and represents the entire HTML page. The document object is a property of `window` and so is accessible globally. A `Document` node has the following characteristics:

- `nodeType` is 9.
- `nodeName` is "#document".
- `nodeValue` is `null`.
- `parentNode` is `null`.
- `ownerDocument` is `null`.
- Child nodes may be a `DocumentType` (maximum of one), `Element` (maximum of one), `ProcessingInstruction`, or `Comment`.

The `Document` type can represent HTML pages or other XML-based documents, though the most common use is through an instance of `HTMLDocument` through the document object. The document object can be used to get information about the page and to manipulate both its appearance and the underlying structure.

Document Children

Though the DOM specification states that the children of a `Document` node can be a `DocumentType`, `Element`, `ProcessingInstruction`, or `Comment`, there are two built-in shortcuts to child nodes. The first is the `documentElement` property, which always points to the `<html>` element in an HTML page. The document element is always represented in the `childNodes` list as well, but the `documentElement` property gives faster and more direct access to that element. Consider the following simple page:

```
<html>
  <body>

  </body>
</html>
```

When this page is parsed by a browser, the document has only one child node, which is the `<html>` element. This element is accessible from both `documentElement` and the `childNodes` list, as shown here:

```
let html = document.documentElement; // get reference to <html>
alert(html === document.childNodes[0]); // true
alert(html === document.firstChild); // true
```

This example shows that the values of `documentElement`, `firstChild`, and `childNodes[0]` are all the same—all three point to the `<html>` element.

As an instance of `HTMLDocument`, the document object also has a `body` property that points to the `<body>` element directly. Because this is the element most often used by developers, `document.body` tends to be used quite frequently in JavaScript, as this example shows:

```
let body = document.body; // get reference to <body>
```

Both `document.documentElement` and `document.body` are supported in all major browsers.

Another possible child node of a `Document` is a `DocumentType`. The `<!DOCTYPE>` tag is considered to be a separate entity from other parts of the document, and its information is accessible through the `doctype` property (`document.doctype` in browsers), as shown here:

```
let doctype = document.doctype; // get reference to <!DOCTYPE>
```

Comments that appear outside of the `<html>` element are, technically, child nodes of the document. Once again, browser support varies greatly as to whether these comments will be recognized and represented appropriately. Consider the following HTML page:

```
<!-- first comment -->
<html>
  <body>

  </body>
</html>
<!-- second comment -->
```

This page seems to have three child nodes: a comment, the `<html>` element, and another comment. Logically, you would expect `document.childNodes` to have three items corresponding to what appears in the code. In practice, however, browsers handle comments outside of the `<html>` element in different ways with respect to ignoring one or both of the comment nodes.

For the most part, the `appendChild()`, `removeChild()`, and `replaceChild()` methods aren't used on `document` because the document type (if present) is read-only and there can be only one element child node (which is already present).

Document Information

The `document` object, as an instance of `HTMLDocument`, has several additional properties that standard `Document` objects do not have. These properties provide information about the web page that is loaded. The first such property is `title`, which contains the text in the `<title>` element and is displayed in the title bar or tab of the browser window. This property can be used to retrieve the current page title and to change the page title such that the changes are reflected in the browser title bar. Changing the value of the `title` property does not change the `<title>` element at all. Here is an example:

```
// get the document title
let originalTitle = document.title;

// set the document title
document.title = "New page title";
```

The next three properties are all related to the request for the web page: `URL`, `domain`, and `referrer`. The `URL` property contains the complete URL of the page (the URL in the address bar), the `domain` property contains just the domain name of the page, and the `referrer` property gives the URL of the page that linked to this page. The `referrer` property may be an empty string if there is no referrer to the page. All of this information is available in the HTTP header of the request and is simply made available in JavaScript via these properties, as shown in the following example:

```
// get the complete URL
let url = document.URL;
```

```
// get the domain
let domain = document.domain;

// get the referrer
let referrer = document.referrer;
```

The URL and domain properties are related. For example, if `document.URL` is `http://www.wrox.com/WileyCDA/`, then `document.domain` will be `www.wrox.com`.

Of these three properties, the `domain` property is the only one that can be set. There are some restrictions as to what the value of `domain` can be set to because of security issues. If the URL contains a subdomain, such as `p2p.wrox.com`, the `domain` may be set only to `"wrox.com"` (the same is true when the URL contains `"www,"` such as `www.wrox.com`). The property can never be set to a domain that the URL doesn't contain, as this example demonstrates:

```
// page from p2p.wrox.com

document.domain = "wrox.com"; // succeeds

document.domain = "nczonline.net"; // error!
```

The ability to set `document.domain` is useful when there is a frame or `iframe` on the page from a different subdomain. Pages from different subdomains can't communicate with one another via JavaScript because of cross-domain security restrictions. By setting `document.domain` in each page to the same value, the pages can access JavaScript objects from each other. For example, if a page is loaded from `www.wrox.com` and it has an `iframe` with a page loaded from `p2p.wrox.com`, each page's `document.domain` string will be different, and the outer page and the inner page are restricted from accessing each other's JavaScript objects. If the `document.domain` value in each page is set to `"wrox.com"`, the pages can then communicate.

A further restriction in the browser disallows tightening of the domain property once it has been loosened. This means you cannot set `document.domain` to `"wrox.com"` and then try to set it back to `"p2p.wrox.com"` because the latter would cause an error, as shown here:

```
// page from p2p.wrox.com

document.domain = "wrox.com"; // loosen - succeeds

document.domain = "p2p.wrox.com"; // tighten - error!
```

Locating Elements

Perhaps the most common DOM activity is to retrieve references to a specific element or sets of elements to perform certain operations. This capability is provided via a number of methods on the `document` object. The `Document` type provides two methods to this end: `getElementById()` and `getElementsByTagName()`.

The `getElementById()` method accepts a single argument—the ID of an element to retrieve—and returns the element if found, or `null` if an element with that ID doesn't exist. The ID must be an exact match, including character case, to the `id` attribute of an element on the page. Consider the following element:

```
<div id="myDiv">Some text</div>
```

This element can be retrieved using the following code:

```
let div = document.getElementById("myDiv"); // retrieve reference to the <div>
```

The following code, however, would return null:

```
let div = document.getElementById("mydiv"); // null
```

If more than one element with the same ID are in a page, `getElementById()` returns the element that appears first in the document.

The `getElementsByTagName()` method is another commonly used method for retrieving element references. It accepts a single argument—the tag name of the elements to retrieve—and returns a `NodeList` containing zero or more elements. In HTML documents, this method returns an `HTMLCollection` object, which is very similar to a `NodeList` in that it is considered a “live” collection. For example, the following code retrieves all `` elements in the page and returns an `HTMLCollection`:

```
let images = document.getElementsByTagName("img");
```

This code stores an `HTMLCollection` object in the `images` variable. As with `NodeList` objects, items in `HTMLCollection` objects can be accessed using bracket notation or the `item()` method. The number of elements in the object can be retrieved via the `length` property, as this example demonstrates:

```
alert(images.length); // output the number of images
alert(images[0].src); // output the src attribute of the first image
alert(images.item(0).src); // output the src attribute of the first image
```

The `HTMLCollection` object has an additional method, `namedItem()`, that lets you reference an item in the collection via its name attribute. For example, suppose you had the following `` element in a page:

```

```

A reference to this `` element can be retrieved from the `images` variable like this:

```
let myImage = images.namedItem("myImage");
```

In this way, an `HTMLCollection` gives you access to named items in addition to indexed items, making it easier to get exactly the elements you want. You can also access named items by using bracket notation, as shown in the following example:

```
let myImage = images["myImage"];
```

For `HTMLCollection` objects, bracket notation can be used with either numeric or string indices. Behind the scenes, a numeric index calls `item()` and a string index calls `namedItem()`.

To retrieve all elements in the document, pass in `*` to `getElementsByTagName()`. The asterisk is generally understood to mean “all” in JavaScript and Cascading Style Sheets (CSS). Here’s an example:

```
let allElements = document.getElementsByTagName("*");
```

This single line of code returns an `HTMLCollection` containing all of the elements in the order in which they appear. So the first item is the `<html>` element, the second is the `<head>` element, and so on.

NOTE *Even though the specification states that tag names are case-sensitive, the `getElementsByTagName()` method is case-insensitive for maximum compatibility with existing HTML pages. When used in XML pages, including XHTML, `getElementsByTagName()` switches to case-sensitive mode.*

A third method, which is defined on the `HTMLDocument` type only, is `getElementsByName()`. As its name suggests, this method returns all elements that have a given name attribute. The `getElementsByName()` method is most often used with radio buttons, all of which must have the same name to ensure the correct value gets sent to the server, as the following example shows:

```
<fieldset>
  <legend>Which color do you prefer?</legend>
  <ul>
    <li>
      <input type="radio" value="red" name="color" id="colorRed">
      <label for="colorRed">Red</label>
    </li>
    <li>
      <input type="radio" value="green" name="color" id="colorGreen">
      <label for="colorGreen">Green</label>
    </li>
    <li>
      <input type="radio" value="blue" name="color" id="colorBlue">
      <label for="colorBlue">Blue</label>
    </li>
  </ul>
</fieldset>
```

In this code, the radio buttons all have a name attribute of "color" even though their IDs are different. The IDs allow the `<label>` elements to be applied to the radio buttons, and the name attribute ensures that only one of the three values will be sent to the server. These radio buttons can all then be retrieved using the following line of code:

```
let radios = document.getElementsByName("color");
```

As with `getElementsByTagName()`, the `getElementsByName()` method returns an `HTMLCollection`. In this context, however, the `namedItem()` method always retrieves the first item (since all items have the same name).

Special Collections

The `document` object has several special collections. Each of these collections is an `HTMLCollection` object and provides faster access to common parts of the document, as described here:

- `document.anchors`—Contains all `<a>` elements with a name attribute in the document.
- `document.applets`—Contains all `<applet>` elements in the document. This collection is deprecated because the `<applet>` element is no longer recommended for use.
- `document.forms`—Contains all `<form>` elements in the document. The same as `document.getElementsByTagName("form")`.

- `document.images`—Contains all `` elements in the document. The same as `document.getElementsByTagName("img")`.
- `document.links`—Contains all `<a>` elements with an `href` attribute in the document.

These special collections are always available on `HTMLDocument` objects and, like all `HTMLCollection` objects, are constantly updated to match the contents of the current document.

DOM Conformance Detection

Because there are multiple levels and multiple parts of the DOM, it became necessary to determine exactly what parts of the DOM a browser has implemented. The `document.implementation` property is an object containing information and functionality tied directly to the browser's implementation of the DOM. DOM Level 1 specifies only one method on `document.implementation`, which is `hasFeature()`. The `hasFeature()` method accepts two arguments: the name and version of the DOM feature to check for. If the browser supports the named feature and version, this method returns `true`, as with this example:

```
let hasXmlDom = document.implementation.hasFeature("XML", "1.0");
```

The various values that can be tested are listed in the following table.

FEATURE	SUPPORTED VERSIONS	DESCRIPTION
Core	1.0, 2.0, 3.0	Basic DOM that spells out the use of a hierarchical tree to represent documents
XML	1.0, 2.0, 3.0	XML extension of the Core that adds support for CDATA sections, processing instructions, and entities
HTML	1.0, 2.0	HTML extension of XML that adds support for HTML-specific elements and entities
Views	2.0	Accomplishes formatting of a document based on certain styles
StyleSheets	2.0	Relates style sheets to documents
CSS	2.0	Support for Cascading Style Sheets Level 1
CSS2	2.0	Support for Cascading Style Sheets Level 2
Events	2.0, 3.0	Generic DOM events
UIEvents	2.0, 3.0	User interface events
TextEvents	3.0	Events fired from text input devices
MouseEvents	2.0, 3.0	Events caused by the mouse (click, mouseover, and so on)
MutationEvents	2.0, 3.0	Events fired when the DOM tree is changed

continues

(continued)

FEATURE	SUPPORTED VERSIONS	DESCRIPTION
MutationNameEvents	3.0	Events fired when DOM elements or element attributes are renamed
HTMLEvents	2.0	HTML 4.01 events
Range	2.0	Objects and methods for manipulating a range in a DOM tree
Traversal	2.0	Methods for traversing a DOM tree
LS	3.0	Loading and saving between files and DOM trees synchronously
LS-Async	3.0	Loading and saving between files and DOM trees asynchronously
Validation	3.0	Methods to modify a DOM tree and still make it valid
XPath	3.0	Language for addressing parts of an XML document

Although it is a nice convenience, the drawback of using `hasFeature()` is that the implementer gets to decide if the implementation is indeed conformant with the various parts of the DOM specification. It's very easy to make this method return `true` for any and all values, but that doesn't necessarily mean that the implementation conforms to all the specifications it claims to. Safari 2.x and earlier, for example, return `true` for some features that aren't fully implemented. In most cases, it's a good idea to use capability detection in addition to `hasFeature()` before using specific parts of the DOM.

Document Writing

One of the older capabilities of the `document` object is the ability to write to the output stream of a web page. This capability comes in the form of four methods: `write()`, `writeln()`, `open()`, and `close()`. The `write()` and `writeln()` methods each accept a string argument to write to the output stream. `write()` simply adds the text as is, whereas `writeln()` appends a new-line character (`\n`) to the end of the string. These two methods can be used as a page is being loaded to dynamically add content to the page, as shown in the following example:

```
<html>
<head>
  <title>document.write() Example</title>
</head>
<body>
  <p>The current date and time is:
  <script type="text/javascript">
    document.write("<strong>" + (new Date()).toString() + "</strong>");
  </script>
</p>
</body>
</html>
```

This example outputs the current date and time as the page is being loaded. The date is enclosed by a `` element, which is treated the same as if it were included in the HTML portion of the page, meaning that a DOM element is created and can later be accessed. Any HTML that is output via `write()` or `writeln()` is treated this way.

The `write()` and `writeln()` methods are often used to dynamically include external resources such as JavaScript files. When including JavaScript files, you must be sure not to include the string `</script>` directly, as the following example demonstrates, because it will be interpreted as the end of a script block and the rest of the code won't execute.

```
<html>
<head>
  <title>document.write() Example</title>
</head>
<body>
  <script type="text/javascript">
    document.write("<script type=\"text/javascript\" src=\"file.js\">" +
      "</script>");
  </script>
</body>
</html>
```

Even though this file looks correct, the closing `</script>` string is interpreted as matching the outermost `<script>` tag, meaning that the text `");` will appear on the page. To avoid this, you simply need to change the string, as shown here:

```
<html>
<head>
  <title>document.write() Example</title>
</head>
<body>
  <script type="text/javascript">
    document.write("<script type=\"text/javascript\" src=\"file.js\">" +
      "</script>");
  </script>
</body>
</html>
```

The string `</script>` no longer registers as a closing tag for the outermost `<script>` tag, so there is no extra content output to the page.

The previous examples use `document.write()` to output content directly into the page as it's being rendered. If `document.write()` is called after the page has been completely loaded, the content overwrites the entire page, as shown in the following example:

```
<html>
<head>
  <title>document.write() Example</title>
</head>
<body>
  <p>This is some content that you won't get to see because it will be
  overwritten.</p>
  <script type="text/javascript">
    window.onload = function(){
      document.write("Hello world!");
    }
  </script>
</body>
</html>
```

```

    };
  </script>
</body>
</html>

```

In this example, the `window.onload` event handler is used to delay the execution of the function until the page is completely loaded. When that happens, the string "Hello world!" overwrites the entire page content.

The `open()` and `close()` methods are used to open and close the web page output stream, respectively. Neither method is required to be used when `write()` or `writeln()` is used during the course of page loading.

NOTE *Document writing is not supported in strict XHTML documents. For pages that are served with the `application/xml+xhtml` content type, these methods will not work.*

The Element Type

Next to the `Document` type, the `Element` type is most often used in web programming. The `Element` type represents an XML or HTML element, providing access to information such as its tag name, children, and attributes. An `Element` node has the following characteristics:

- `nodeType` is 1.
- `nodeName` is the element's tag name.
- `nodeValue` is null.
- `parentNode` may be a `Document` or `Element`.
- Child nodes may be `Element`, `Text`, `Comment`, `ProcessingInstruction`, `CDATASection`, or `EntityReference`.

An element's tag name is accessed via the `nodeName` property or by using the `tagName` property; both properties return the same value (the latter is typically used for clarity). Consider the following element:

```
<div id="myDiv"></div>
```

This element can be retrieved and its tag name accessed in the following way:

```

let div = document.getElementById("myDiv");
alert(div.tagName); // "DIV"
alert(div.tagName == div.nodeName); // true

```

The element in question has a tag name of `div` and an ID of `"myDiv"`. Note, however, that `div.tagName` actually outputs `"DIV"` instead of `"div"`. When used with HTML, the tag name is always represented in all uppercase; when used with XML (including XHTML), the tag name always matches the

case of the source code. If you aren't sure whether your script will be on an HTML or XML document, it's best to convert tag names to a common case before comparison, as this example shows:

```
if (element.tagName == "div"){ // AVOID! Error prone!
  // do something here
}

if (element.tagName.toLowerCase() == "div"){ // Preferred - works in all documents
  // do something here
}
```

This example shows two comparisons against a `tagName` property. The first is quite error prone because it won't work in HTML documents. The second approach, converting the tag name to all lowercase, is preferred because it will work for both HTML and XML documents.

HTML Elements

All HTML elements are represented by the `HTMLElement` type, either directly or through subtyping. The `HTMLElement` inherits directly from `Element` and adds several properties. Each property represents one of the following standard attributes that are available on every HTML element:

- `id`—A unique identifier for the element in the document.
- `title`—Additional information about the element, typically represented as a tooltip.
- `lang`—The language code for the contents of the element (rarely used).
- `dir`—The direction of the language, `"ltr"` (left-to-right) or `"rtl"` (right-to-left); also rarely used.
- `className`—The equivalent of the `class` attribute, which is used to specify CSS classes on an element. The property could not be named `class` because `class` is an ECMAScript reserved word.

Each of these properties can be used both to retrieve the corresponding attribute value and to change the value. Consider the following HTML element:

```
<div id="myDiv" class="bd" title="Body text" lang="en" dir="ltr"></div>
```

All of the information specified by this element may be retrieved using the following JavaScript code:

```
let div = document.getElementById("myDiv");
alert(div.id); // "myDiv"
alert(div.className); // "bd"
alert(div.title); // "Body text"
alert(div.lang); // "en"
alert(div.dir); // "ltr"
```

It's also possible to use the following code to change each of the attributes by assigning new values to the properties:

```
div.id = "someOtherId";
div.className = "ft";
div.title = "Some other text";
div.lang = "fr";
div.dir = "rtl";
```

Not all of the properties affect the page when overwritten. Changes to `id` or `lang` will be transparent to the user (assuming no CSS styles are based on these values), whereas changes to `title` will be apparent only when the mouse is moved over the element. Changes to `dir` will cause the text on the page to be aligned to either the left or the right as soon as the property is written. Changes to `className` may appear immediately if the class has different CSS style information than the previous one.

As mentioned previously, all HTML elements are represented by an instance of `HTMLElement` or a more specific subtype. The following table lists each HTML element and its associated type (italicized elements are deprecated).

ELEMENT	TYPE	ELEMENT	TYPE
A	<code>HTMLAnchorElement</code>	INPUT	<code>HTMLInputElement</code>
ABBR	<code>HTMLElement</code>	INS	<code>HTMLModElement</code>
ACRONYM	<code>HTMLElement</code>	<i>ISINDEX</i>	<i>HTMLIsIndexElement</i>
ADDRESS	<code>HTMLElement</code>	KBD	<code>HTMLElement</code>
<i>APPLET</i>	<i>HTMLAppletElement</i>	LABEL	<code>HTMLLabelElement</code>
AREA	<code>HTMLAreaElement</code>	LEGEND	<code>HTMLLegendElement</code>
B	<code>HTMLElement</code>	LI	<code>HTMLLIElement</code>
BASE	<code>HTMLBaseElement</code>	LINK	<code>HTMLLinkElement</code>
<i>BASEFONT</i>	<i>HTMLBaseFontElement</i>	MAP	<code>HTMLMapElement</code>
BDO	<code>HTMLElement</code>	<i>MENU</i>	<i>HTMLMenuElement</i>
BIG	<code>HTMLElement</code>	META	<code>HTMLMetaElement</code>
BLOCKQUOTE	<code>HTMLQuoteElement</code>	NOFRAMES	<code>HTMLElement</code>
BODY	<code>HTMLBodyElement</code>	NOSCRIPT	<code>HTMLElement</code>
BR	<code>HTMLBRElement</code>	OBJECT	<code>HTMLObjectElement</code>
BUTTON	<code>HTMLButtonElement</code>	OL	<code>HTMLOListElement</code>
CAPTION	<code>HTMLTableCaptionElement</code>	OPTGROUP	<code>HTMLOptGroupElement</code>
<i>CENTER</i>	<i>HTMLElement</i>	OPTION	<code>HTMLOptionElement</code>
CITE	<code>HTMLElement</code>	P	<code>HTMLParagraphElement</code>
CODE	<code>HTMLElement</code>	PARAM	<code>HTMLParamElement</code>
COL	<code>HTMLTableColElement</code>	PRE	<code>HTMLPreElement</code>
COLGROUP	<code>HTMLTableColElement</code>	Q	<code>HTMLQuoteElement</code>

ELEMENT	TYPE	ELEMENT	TYPE
DD	HTML <code>Element</code>	S	<i>HTML<code>Element</code></i>
DEL	HTML <code>ModElement</code>	SAMP	HTML <code>Element</code>
DFN	HTML <code>Element</code>	SCRIPT	HTML <code>ScriptElement</code>
<i>DIR</i>	<i>HTML<code>DirectoryElement</code></i>	SELECT	HTML <code>SelectElement</code>
DIV	HTML <code>DivElement</code>	SMALL	HTML <code>Element</code>
DL	HTML <code>DLListElement</code>	SPAN	HTML <code>Element</code>
DT	HTML <code>Element</code>	<i>STRIKE</i>	<i>HTML<code>Element</code></i>
EM	HTML <code>Element</code>	STRONG	HTML <code>Element</code>
FIELDSET	HTML <code>FieldSetElement</code>	STYLE	HTML <code>StyleElement</code>
FONT	<i>HTML<code>FontElement</code></i>	SUB	HTML <code>Element</code>
FORM	HTML <code>FormElement</code>	SUP	HTML <code>Element</code>
FRAME	HTML <code>FrameElement</code>	TABLE	HTML <code>TableElement</code>
FRAMESET	HTML <code>FrameSetElement</code>	TBODY	HTML <code>TableSectionElement</code>
H1	HTML <code>HeadingElement</code>	TD	HTML <code>TableCellElement</code>
H2	HTML <code>HeadingElement</code>	TEXTAREA	HTML <code>TextAreaElement</code>
H3	HTML <code>HeadingElement</code>	TFOOT	HTML <code>TableSectionElement</code>
H4	HTML <code>HeadingElement</code>	TH	HTML <code>TableCellElement</code>
H5	HTML <code>HeadingElement</code>	THEAD	HTML <code>TableSectionElement</code>
H6	HTML <code>HeadingElement</code>	TITLE	HTML <code>TitleElement</code>
HEAD	HTML <code>HeadElement</code>	TR	HTML <code>TableRowElement</code>
HR	HTML <code>HRElement</code>	TT	HTML <code>Element</code>
HTML	HTML <code>HtmlElement</code>	U	<i>HTML<code>Element</code></i>
I	HTML <code>Element</code>	UL	HTML <code>ULListElement</code>
IFRAME	HTML <code>IFrameElement</code>	VAR	HTML <code>Element</code>
IMG	HTML <code>ImageElement</code>		

Each of these types has attributes and methods associated with it. Many of these types are discussed throughout this book.

Getting Attributes

Each element may have zero or more attributes, which are typically used to give extra information about the particular element or its contents. The three primary DOM methods for working with attributes are `getAttribute()`, `setAttribute()`, and `removeAttribute()`. These methods are intended to work on any attribute, including those defined as properties on the `HTMLElement` type. Here's an example:

```
let div = document.getElementById("myDiv");
alert(div.getAttribute("id")); // "myDiv"
alert(div.getAttribute("class")); // "bd"
alert(div.getAttribute("title")); // "Body text"
alert(div.getAttribute("lang")); // "en"
alert(div.getAttribute("dir")); // "ltr"
```

Note that the attribute name passed into `getAttribute()` is exactly the same as the actual attribute name, so you pass in `"class"` to get the value of the `class` attribute (not `className`, which is necessary when the attribute is accessed as an object property). If the attribute with the given name doesn't exist, `getAttribute()` always returns `null`.

The `getAttribute()` method can also retrieve the value of custom attributes that aren't part of the formal HTML language. Consider the following element:

```
<div id="myDiv" my_special_attribute="hello!"></div>
```

In this element, a custom attribute named `my_special_attribute` is defined to have a value of `"hello!"`. This value can be retrieved using `getAttribute()` just like any other attribute, as shown here:

```
let value = div.getAttribute("my_special_attribute");
```

Note that attribute names are case-insensitive, so `"ID"` and `"id"` are considered the same attribute. Also note that, according to HTML5, custom attributes should be prepended with `data-` in order to validate.

All attributes on an element are also accessible as properties of the DOM element object itself. There are, of course, the five properties defined on `HTMLElement` that map directly to corresponding attributes, but all recognized (noncustom) attributes get added to the object as properties. Consider the following element:

```
<div id="myDiv" align="left" my_special_attribute="hello"></div>
```

Because `id` and `align` are recognized attributes for the `<div>` element in HTML, they will be represented by properties on the element object. The `my_special_attribute` attribute is custom and so won't show up as a property on the element.

Two types of attributes have property names that don't map directly to the same value returned by `getAttribute()`. The first attribute is `style`, which is used to specify stylistic information about the element using CSS. When accessed via `getAttribute()`, the `style` attribute contains CSS text while accessing it via a property that returns an object. The `style` property is used to programmatically access the styling of the element and so does not map directly to the `style` attribute.

The second category of attribute that behaves differently is event-handler attributes such as `onclick`. When used on an element, the `onclick` attribute contains JavaScript code, and that code string is

returned when using `getAttribute()`. When the `onclick` property is accessed, however, it returns a JavaScript function (or `null` if the attribute isn't specified). This is because `onclick` and other event-handling properties are provided such that functions can be assigned to them.

Because of these differences, developers tend to forego `getAttribute()` when programming the DOM in JavaScript and instead use the object properties exclusively. The `getAttribute()` method is used primarily to retrieve the value of a custom attribute.

Setting Attributes

The sibling method to `getAttribute()` is `setAttribute()`, which accepts two arguments: the name of the attribute to set and the value to set it to. If the attribute already exists, `setAttribute()` replaces its value with the one specified; if the attribute doesn't exist, `setAttribute()` creates it and sets its value. Here is an example:

```
div.setAttribute("id", "someOtherId");
div.setAttribute("class", "ft");
div.setAttribute("title", "Some other text");
div.setAttribute("lang", "fr");
div.setAttribute("dir", "rtl");
```

The `setAttribute()` method works with both HTML attributes and custom attributes in the same way. Attribute names get normalized to lowercase when set using this method, so `ID` ends up as `id`.

Because all attributes are properties, assigning directly to the property can set the attribute values, as shown here:

```
div.id = "someOtherId";
div.align = "left";
```

Note that adding a custom property to a DOM element, as the following example shows, does not automatically make it an attribute of the element:

```
div.mycolor = "red";
alert(div.getAttribute("mycolor")); // null (except in Internet Explorer)
```

This example adds a custom property named `mycolor` and sets its value to `red`. In most browsers, this property does not automatically become an attribute on the element, so calling `getAttribute()` to retrieve an attribute with the same name returns `null`.

The last method is `removeAttribute()`, which removes the attribute from the element altogether. This does more than just clear the attribute's value; it completely removes the attribute from the element, as shown here:

```
div.removeAttribute("class");
```

This method isn't used very frequently, but it can be useful for specifying exactly which attributes to include when serializing a DOM element.

The attributes Property

The `Element` type is the only DOM node type that uses the `attributes` property. The `attributes` property contains a `NamedNodeMap`, which is a "live" collection similar to a `NodeList`. Every attribute on an element is represented by an `Attr` node, each of which is stored in the `NamedNodeMap` object. A `NamedNodeMap` object has the following methods:

- `getNamedItem(name)`—Returns the node whose `nodeName` property is equal to *name*.
- `removeNamedItem(name)`—Removes the node whose `nodeName` property is equal to *name* from the list.
- `setNamedItem(node)`—Adds the node to the list, indexing it by its `nodeName` property.
- `item(pos)`—Returns the node in the numerical position *pos*.

Each node in the `attributes` property is a node whose `nodeName` is the attribute name and whose `nodeValue` is the attribute's value. To retrieve the `id` attribute of an element, you can use the following code:

```
let id = element.attributes.getNamedItem("id").nodeValue;
```

Following is a shorthand notation for accessing attributes by name using bracket notation:

```
let id = element.attributes["id"].nodeValue;
```

It's possible to use this notation to set attribute values as well, retrieving the attribute node and then setting the `nodeValue` to a new value, as this example shows:

```
element.attributes["id"].nodeValue = "someOtherId";
```

The `removeNamedItem()` method functions the same as the `removeAttribute()` method on the element—it simply removes the attribute with the given name. The following example shows how the sole difference is that `removeNamedItem()` returns the `Attr` node that represented the attribute:

```
let oldAttr = element.attributes.removeNamedItem("id");
```

The `setNamedItem()` is a rarely used method that allows you to add a new attribute to the element by passing in an attribute node, as shown in this example:

```
element.attributes.setNamedItem(newAttr);
```

Generally speaking, because of their simplicity, the `getAttribute()`, `removeAttribute()`, and `setAttribute()` methods are preferred to using any of the preceding attribute methods.

The one area where the `attributes` property is useful is to iterate over the attributes on an element. This is done most often when serializing a DOM structure into an XML or HTML string. The following code iterates over each attribute on an element and constructs a string in the format *attribute1="value1" attribute2="value2"*:

```
function outputAttributes(element) {  
  let pairs = [];  
  
  for (let i = 0, len = element.attributes.length; i < len; ++i) {  
    const attribute = element.attributes[i];  
    pairs.push(`${attribute.nodeName}="${attribute.nodeValue}"`);  
  }  
  
  return pairs.join(" ");  
}
```

This function uses an array to store the name-value pairs until the end, concatenating them with a space in between. (This technique is frequently used when serializing into long strings.) Using the `attributes.length` property, the `for` loop iterates over each attribute, outputting the name and

value into a string. Browsers differ on the order in which they return attributes in the `attributes` object. The order in which the attributes appear in the HTML or XML code may not necessarily be the order in which they appear in the `attributes` object.

Creating Elements

New elements can be created by using the `document.createElement()` method. This method accepts a single argument, which is the tag name of the element to create. In HTML documents, the tag name is case-insensitive, whereas it is case-sensitive in XML documents (including XHTML). To create a `<div>` element, the following code can be used:

```
let div = document.createElement("div");
```

Using the `createElement()` method creates a new element and sets its `ownerDocument` property. At this point, you can manipulate the element's attributes, add more children to it, and so on. Consider the following example:

```
div.id = "myNewDiv";
div.className = "box";
```

Setting these attributes on the new element assigns information only. Because the element is not part of the document tree, it doesn't affect the browser's display. The element can be added to the document tree using `appendChild()`, `insertBefore()`, or `replaceChild()`. The following code adds the newly created element to the document's `<body>` element:

```
document.body.appendChild(div);
```

Once the element has been added to the document tree, the browser renders it immediately. Any changes to the element after this point are immediately reflected by the browser.

Element Children

Elements may have any number of children and descendants because elements may be children of elements. The `childNodes` property contains all of the immediate children of the element, which may be other elements, text nodes, comments, or processing instructions. There is a significant difference between browsers regarding the identification of these nodes. For example, consider the following code:

```
<ul id="myList">
  <li>Item 1</li>
  <li>Item 2</li>
  <li>Item 3</li>
</ul>
```

When this code is parsed, the `` element will have seven elements: three `` elements and four text nodes representing the white space between `` elements. If the white space between elements is removed, as the following example demonstrates, all browsers return the same number of child nodes:

```
<ul id="myList"><li>Item 1</li><li>Item 2</li><li>Item 3</li></ul>
```

Using this code, browsers return three child nodes for the `` element. Oftentimes, it's necessary to check the `nodeType` before performing an action, as the following example shows:

```
for (let i = 0, len = element.childNodes.length; i < len; ++i) {  
  if (element.childNodes[i].nodeType == 1) {  
    // do processing  
  }  
}
```

This code loops through each child node of a particular element and performs an operation only if `nodeType` is equal to 1 (the `element` node type identified).

To get child nodes and other descendants with a particular tag name, elements also support the `getElementsByTagName()` method. When used on an element, this method works exactly the same as the document version except that the search is rooted on the element, so only descendants of that element are returned. In the `` code earlier in this section, all `` elements can be retrieved using the following code:

```
let ul = document.getElementById("myList");  
let items = ul.getElementsByTagName("li");
```

Keep in mind that this works because the `` element has only one level of descendants. If there were more levels, all `` elements contained in all levels would be returned.

The Text Type

`Text` nodes are represented by the `Text` type and contain plain text that is interpreted literally and may contain escaped HTML characters but no HTML code. A `Text` node has the following characteristics:

- `nodeType` is 3.
- `nodeName` is `"#text"`.
- `nodeValue` is text contained in the node.
- `parentNode` is an `Element`.
- Child nodes are not supported.

The text contained in a `Text` node may be accessed via either the `nodeValue` property or the `data` property, both of which contain the same value. Changes to either `nodeValue` or `data` are reflected in the other as well. The following methods allow for manipulation of the text in the node:

- `appendData(text)`—Appends *text* to the end of the node.
- `deleteData(offset, count)`—Deletes *count* number of characters starting at position *offset*.
- `insertData(offset, text)`—Inserts *text* at position *offset*.
- `replaceData(offset, count, text)`—Replaces the text starting at *offset* through *offset* + *count* with *text*.
- `splitText(offset)`—Splits the text node into two `Text` nodes separated at position *offset*.
- `substringData(offset, count)`—Extracts a string from the text beginning at position *offset* and continuing until *offset* + *count*.

In addition to these methods, the `length` property returns the number of characters in the node. This value is the same as using `nodeValue.length` or `data.length`.

By default, every element that may contain content will have at most one text node when content is present. Here is an example:

```
<!-- no content, so no text node -->
<div></div>

<!-- white space content, so one text node -->
<div> </div>

<!-- content, so one text node -->
<div>Hello World!</div>
```

The first `<div>` element in this code has no content, so there is no text node. Any content between the opening and closing tags means that a text node must be created, so the second `<div>` element has a single text node as a child even though its content is white space. The text node's `nodeValue` is a single space. The third `<div>` also has a single text node whose `nodeValue` is "Hello World!". The following code lets you access this node:

```
let textNode = div.firstChild; // or div.childNodes[0]
```

Once a reference to the text node is retrieved, it can be changed like this:

```
div.firstChild.nodeValue = "Some other message";
```

As long as the node is currently in the document tree, the changes to the text node will be reflected immediately. Another note about changing the value of a text node is that the string is HTML- or XML-encoded (depending on the type of document), meaning that any less-than symbols, greater-than symbols, or quotation marks are escaped, as shown in this example:

```
// outputs as "Some &lt;strong&gt;other&lt;/strong&gt; message"
div.firstChild.nodeValue = "Some <strong>other</strong> message";
```

This is an effective way of HTML-encoding a string before inserting it into the DOM document.

Creating Text Nodes

New text nodes can be created using the `document.createTextNode()` method, which accepts a single argument—the text to be inserted into the node. As with setting the value of an existing text node, the text will be HTML- or XML-encoded, as shown in this example:

```
let textNode = document.createTextNode("<strong>Hello</strong> world!");
```

When a new text node is created, its `ownerDocument` property is set, but it does not appear in the browser window until it is added to a node in the document tree. The following code creates a new `<div>` element and adds a message to it:

```
let element = document.createElement("div");
element.className = "message";

let textNode = document.createTextNode("Hello world!");
element.appendChild(textNode);

document.body.appendChild(element);
```

This example creates a new `<div>` element and assigns it a `class` of `"message"`. Then a text node is created and added to that element. The last step is to add the element to the document's body, which makes both the element and the text node appear in the browser.

Typically, elements have only one text node as a child. However, it is possible to have multiple text nodes as children, as this example demonstrates:

```
let element = document.createElement("div");
element.className = "message";

let textNode = document.createTextNode("Hello world!");
element.appendChild(textNode);

let anotherTextNode = document.createTextNode("Yippee!");
element.appendChild(anotherTextNode);

document.body.appendChild(element);
```

When a text node is added as a sibling of another text node, the text in those nodes is displayed without any space between them.

Normalizing Text Nodes

Sibling text nodes can be confusing in DOM documents because there is no simple text string that can't be represented in a single text node. Still, it is not uncommon to come across sibling text nodes in DOM documents, so there is a method to join sibling text nodes together. This method is called `normalize()`, and it exists on the `Node` type (and thus is available on all node types). When `normalize()` is called on a parent of two or more text nodes, those nodes are merged into one text node whose `nodeValue` is equal to the concatenation of the `nodeValue` properties of each text node. Here's an example:

```
let element = document.createElement("div");
element.className = "message";

let textNode = document.createTextNode("Hello world!");
element.appendChild(textNode);

let anotherTextNode = document.createTextNode("Yippee!");
element.appendChild(anotherTextNode);

document.body.appendChild(element);

alert(element.childNodes.length);    // 2

element.normalize();
alert(element.childNodes.length);    // 1
alert(element.firstChild.nodeValue); // "Hello world!Yippee!"
```

When the browser parses a document, it will never create sibling text nodes. Sibling text nodes can appear only by programmatic DOM manipulation.

Splitting Text Nodes

The `Text` type has a method that does the opposite of `normalize()`: the `splitText()` method splits a text node into two text nodes, separating the `nodeValue` at a given offset. The original text node contains the text up to the specified offset, and the new text node contains the rest of the text. The method returns the new text node, which has the same `parentNode` as the original. Consider the following example:

```
let element = document.createElement("div");
element.className = "message";

let textNode = document.createTextNode("Hello world!");
element.appendChild(textNode);

document.body.appendChild(element);

let newNode = element.firstChild.splitText(5);
alert(element.firstChild.nodeValue); // "Hello"
alert(newNode.nodeValue);           // " world!"
alert(element.childNodes.length);   // 2
```

In this example, the text node containing the text "Hello world!" is split into two text nodes at position 5. Position 5 contains the space between "Hello" and "world!", so the original text node has the string "Hello" and the new one has the text " world!" (including the space).

Splitting text nodes is used most often with DOM parsing techniques for extracting data from text nodes.

The Comment Type

Comments are represented in the DOM by the `Comment` type. A `Comment` node has the following characteristics:

- `nodeType` is 8.
- `nodeName` is "#comment".
- `nodeValue` is the content of the comment.
- `parentNode` is a `Document` or `Element`.
- Child nodes are not supported.

The `Comment` type inherits from the same base as the `Text` type, so it has all of the same string-manipulation methods except `splitText()`. Also similar to the `Text` type, the actual content of the comment may be retrieved using either `nodeValue` or the `data` property.

A comment node can be accessed as a child node from its parent. Consider the following HTML code:

```
<div id="myDiv"><!-- A comment --></div>
```

In this case, the comment is a child node of the `<div>` element, which means it can be accessed like this:

```
let div = document.getElementById("myDiv");
let comment = div.firstChild;
alert(comment.data); // "A comment"
```

Comment nodes can also be created using the `document.createComment()` method and passing in the comment text, as shown in the following code:

```
let comment = document.createComment("A comment");
```

Not surprisingly, comment nodes are rarely accessed or created, because they serve very little purpose algorithmically. Additionally, browsers don't recognize comments that exist after the closing `</html>` tag. If you need to access comment nodes, make sure they appear as descendants of the `<html>` element.

The CDATASection Type

CDATA sections are specific to XML-based documents and are represented by the `CDATASection` type. Similar to `Comment`, the `CDATASection` type inherits from the base `Text` type, so it has all of the same string manipulation methods except for `splitText()`. A `CDATASection` node has the following characteristics:

- `nodeType` is 4.
- `nodeName` is `"#cdata-section"`.
- `nodeValue` is the contents of the CDATA section.
- `parentNode` is a `Document` or `Element`.
- Child nodes are not supported.

CDATA sections are valid only in XML documents, so most browsers will incorrectly parse a CDATA section into either a `Comment` or an `Element`. Consider the following:

```
<div id="myDiv"><![CDATA[This is some content.]]></div>
```

In this example, a `CDATASection` node should exist as the first child of the `<div>`; however, none of the four major browsers interpret it as such. Even in valid XHTML pages, the browsers don't properly support embedded CDATA sections.

True XML documents allow the creation of CDATA sections using `document.createCDATASection()` and pass in the node's content.

The DocumentType Type

A `DocumentType` object contains all of the information about the document's doctype and has the following characteristics:

- `nodeType` is 10.
- `nodeName` is the name of the doctype.

- `nodeValue` is null.
- `parentNode` is a `Document`.
- Child nodes are not supported.

`DocumentType` objects cannot be created dynamically in DOM Level 1; they are created only as the document's code is being parsed. For browsers that support it, the `DocumentType` object is stored in `document.doctype`. DOM Level 1 describes three properties for `DocumentType` objects: `name`, which is the name of the doctype; `entities`, which is a `NamedNodeMap` of entities described by the doctype; and `notations`, which is a `NamedNodeMap` of notations described by the doctype. Because documents in browsers typically use an HTML or XHTML doctype, the `entities` and `notations` lists are typically empty. (They are filled only with inline doctypes.) For all intents and purposes, the `name` property is the only useful one available. This property is filled with the name of the doctype, which is the text that appears immediately after `<!DOCTYPE`. Consider the following HTML 4.01 strict doctype:

```
<!DOCTYPE HTML PUBLIC "-// W3C// DTD HTML 4.01// EN"
"http:// www.w3.org/TR/html4/strict.dtd">
```

For this doctype, the `name` property is "HTML":

```
alert(document.doctype.name); // "HTML"
```

The DocumentFragment Type

Of all the node types, the `DocumentFragment` type is the only one that has no representation in markup. The DOM defines a document fragment as a “lightweight” document, capable of containing and manipulating nodes without all of the additional overhead of a complete document. `DocumentFragment` nodes have the following characteristics:

- `nodeType` is 11.
- `nodeName` is "#document-fragment".
- `nodeValue` is null.
- `parentNode` is null.
- Child nodes may be `Element`, `ProcessingInstruction`, `Comment`, `Text`, `CDATASection`, or `EntityReference`.

A document fragment cannot be added to a document directly. Instead, it acts as a repository for other nodes that may need to be added to the document. Document fragments are created using the `document.createDocumentFragment()` method, shown here:

```
let fragment = document.createDocumentFragment();
```

Document fragments inherit all methods from `Node` and are typically used to perform DOM manipulations that are to be applied to a document. If a node from the document is added to a document fragment, that node is removed from the document tree and won't be rendered by the browser. New nodes that are added to a document fragment are also not part of the document tree. The contents of a document fragment can be added to a document via `appendChild()` or `insertBefore()`. When

a document fragment is passed in as an argument to either of these methods, all of the document fragment's child nodes are added in that spot; the document fragment itself is never added to the document tree. For example, consider the following HTML:

```
<ul id="myList"></ul>
```

Suppose you would like to add three list items to this `` element. Adding each item directly to the element causes the browser to rerender the page with the new information. To avoid this, the following code example uses a document fragment to create the list items and then add them all at the same time:

```
let fragment = document.createDocumentFragment();
let ul = document.getElementById("myList");

for (let i = 0; i < 3; ++i) {
  let li = document.createElement("li");
  li.appendChild(document.createTextNode(`Item ${i + 1}`));
  fragment.appendChild(li);
}

ul.appendChild(fragment);
```

This example begins by creating a document fragment and retrieving a reference to the `` element. The `for` loop creates three list items, each with text indicating which item they are. To do this, an `` element is created and then a text node is created and added to that element. The `` element is then added to the document fragment using `appendChild()`. When the loop is complete, all of the items are added to the `` element by calling `appendChild()` and passing in the document fragment. At that point, the document fragment's child nodes are all removed and placed onto the `` element.

The Attr Type

Element attributes are represented by the `Attr` type in the DOM. The `Attr` type constructor and prototype are accessible in all browsers. Technically, attributes are nodes that exist in an element's `attributes` property. Attribute nodes have the following characteristics:

- `nodeType` is 11.
- `nodeName` is the attribute name.
- `nodeValue` is the attribute value.
- `parentNode` is `null`.
- Child nodes are not supported in HTML.
- Child nodes may be `Text` or `EntityReference` in XML.

Even though they are nodes, attributes are not considered part of the DOM document tree. Attribute nodes are rarely referenced directly, with most developers favoring the use of `getAttribute()`, `setAttribute()`, and `removeAttribute()`.

There are three properties on an `Attr` object: `name`, which is the attribute name (same as `nodeName`); `value`, which is the attribute value (same as `nodeValue`); and `specified`, which is a Boolean value indicating if the attribute was specified in code or if it is a default value.

New attribute nodes can be created by using `document.createAttribute()` and passing in the name of the attribute. For example, to add an `align` attribute to an element, the following code can be used:

```
let attr = document.createAttribute("align");
attr.value = "left";
element.setAttributeNode(attr);

alert(element.attributes["align"].value); // "left"
alert(element.getAttributeNode("align").value); // "left"
alert(element.getAttribute("align")); // "left"
```

In this example, a new attribute node is created. The `name` property is assigned by the call to `createAttribute()`, so there is no need to assign it directly afterward. The `value` property is then assigned to `"left"`. To add the newly created attribute to an element, you can use the element's `setAttributeNode()` method. Once the attribute is added, it can be accessed in any number of ways: via the `attributes` property, using `getAttributeNode()`, or using `getAttribute()`. Both `attributes` and `getAttributeNode()` return the actual `Attr` node for the attribute, whereas `getAttribute()` returns only the attribute value.

NOTE *There is really not a good reason to access attribute nodes directly. The `getAttribute()`, `setAttribute()`, and `removeAttribute()` methods are preferable over manipulating attribute nodes.*

WORKING WITH THE DOM

In many cases, working with the DOM is fairly straightforward, making it easy to re-create with JavaScript what normally would be created using HTML code. There are, however, times when using the DOM is not as simple as it may appear. Browsers are filled with hidden gotchas and incompatibilities that make coding certain parts of the DOM more complicated than coding its other parts.

Dynamic Scripts

The `<script>` element is used to insert JavaScript code into the page, either by using the `src` attribute to include an external file or by including text inside the element itself. Dynamic scripts are those that don't exist when the page is loaded but are included later by using the DOM. As with the HTML element, there are two ways to do this: pulling in an external file or inserting text directly.

Dynamically loading an external JavaScript file works as you would expect. Consider the following `<script>` element:

```
<script src="foo.js"></script>
```

The DOM code to create this node is as follows:

```
let script = document.createElement("script");
script.src = "foo.js";
document.body.appendChild(script);
```

As you can see, the DOM code exactly mirrors the HTML code that it represents. Note that the external file is not downloaded until the `<script>` element is added to the page on the last line. The element could be added to the `<head>` element as well, though this has the same effect. This process can be generalized into the following function:

```
function loadScript(url) {
    let script = document.createElement("script");
    script.src = url;
    document.body.appendChild(script);
}
```

This function can now be used to load external JavaScript files via the following call:

```
loadScript("client.js");
```

Once loaded, the script is fully available to the rest of the page. This leaves only one problem: how do you know when the script has been fully loaded? Unfortunately, there is no standard way to handle this. Some events are available depending on the browser being used, as discussed in the *Events* chapter.

The other way to specify JavaScript code is inline, as in this example:

```
<script>
    function sayHi() {
        alert("hi");
    }
</script>
```

Using the DOM, it would be logical for the following to work:

```
let script = document.createElement("script");
script.appendChild(document.createTextNode("function sayHi() {alert('hi');}"));
document.body.appendChild(script);
```

This works in Firefox, Safari, Chrome, and Opera. In older versions of Internet Explorer, however, this causes an error. Internet Explorer treats `<script>` elements as special and won't allow regular DOM access to child nodes. A property called `text` exists on all `<script>` elements that can be used specifically to assign JavaScript code to, as in the following example:

```
var script = document.createElement("script");
script.text = "function sayHi(){alert('hi');}";
document.body.appendChild(script);
```

This updated code works in Internet Explorer, Firefox, Opera, and Safari 3 and later. Safari versions prior to 3 don't support the `text` property correctly; however, these older versions will allow the assignment of code using the `text-node` technique. If you need to do this in an earlier Safari version, the following code can be used:

```
var script = document.createElement("script");
var code = "function sayHi(){alert('hi');}";
try {
    script.appendChild(document.createTextNode("code"));
} catch (ex){
    script.text = "code";
}
document.body.appendChild(script);
```

Here, the standard DOM text-node method is attempted first because it works in everything but Internet Explorer, which will throw an error. If that line causes an error, that means it is Internet Explorer, and the `text` property must be used. This can be generalized into the following function:

```
function loadScriptString(code) {
  var script = document.createElement("script");
  script.type = "text/javascript";
  try {
    script.appendChild(document.createTextNode(code));
  } catch (ex) {
    script.text = code;
  }
  document.body.appendChild(script);
}
```

The function is called as follows:

```
loadScriptString("function sayHi () {alert ('hi');}");
```

Code loaded in this manner is executed in the global scope and is available immediately after the script finishes executing. This is essentially the same as passing the string into `eval()` in the global scope.

Importantly, all `<script>` elements created with `innerHTML` will never execute. The browser will dutifully create the `<script>` element and the script text inside it, but the parser will flag the `<script>` element as one that should never execute. Once created using `innerHTML`, there is no way to force the script to run later.

Dynamic Styles

CSS styles are included in HTML pages using one of two elements. The `<link>` element is used to include CSS from an external file, whereas the `<style>` element is used to specify inline styles. Similar to dynamic scripts, dynamic styles don't exist on the page when it is loaded initially; rather, they are added after the page has been loaded.

Consider this typical `<link>` element:

```
<link rel="stylesheet" type="text/css" href="styles.css">
```

This element can just as easily be created using the following DOM code:

```
let link = document.createElement("link");
link.rel = "stylesheet";
link.type = "text/css";
link.href = "styles.css";
let head = document.getElementsByTagName("head")[0];
head.appendChild(link);
```

This code works in all major browsers without any issue. Note that `<link>` elements should be added to the `<head>` instead of the `body` for this to work properly in all browsers. The technique can be generalized into the following function:

```
function loadStyles(url) {
  let link = document.createElement("link");
  link.rel = "stylesheet";
```

```
    link.type = "text/css";
    link.href = url;
    let head = document.getElementsByTagName("head")[0];
    head.appendChild(link);
  }
```

The `loadStyles()` function can then be called like this:

```
loadStyles("styles.css");
```

Loading styles via an external file is asynchronous, so the styles will load out of order with the JavaScript code being executed. Typically, it's not necessary to know when the styles have been fully loaded.

The other way to define styles is using the `<style>` element and including inline CSS, such as this:

```
<style type="text/css">
body {
  background-color: red;
}
</style>
```

Logically, the following DOM code should work:

```
let style = document.createElement("style");
style.type = "text/css";
style.appendChild(document.createTextNode("body{background-color:red}"));
let head = document.getElementsByTagName("head")[0];
head.appendChild(style);
```

This code works in Firefox, Safari, Chrome, and Opera but not in Internet Explorer. Internet Explorer treats `<style>` nodes as special, similar to `<script>` nodes, and so won't allow access to its child nodes. In fact, Internet Explorer throws the same error as when you try to add a child node to a `<script>` element. The workaround for Internet Explorer is to access the element's `styleSheet` property, which in turn has a property called `cssText` that may be set to CSS code as this code sample shows:

```
let style = document.createElement("style");
style.type = "text/css";
try{
  style.appendChild(document.createTextNode("body{background-color:red}"));
} catch (ex){
  style.styleSheet.cssText = "body{background-color:red}";
}
let head = document.getElementsByTagName("head")[0];
head.appendChild(style);
```

Similar to the code for adding inline scripts dynamically, this new code uses a `try-catch` statement to catch the error that Internet Explorer throws and then responds by using the Internet Explorer-specific way of setting styles. The generic solution is as follows:

```
function loadStyleString(css) {
  let style = document.createElement("style");
  style.type = "text/css";
  try{
    style.appendChild(document.createTextNode(css));
  } catch (ex){
    style.styleSheet.cssText = css;
  }
  let head = document.getElementsByTagName("head")[0];
```

```
    head.appendChild(style);
  }
```

The function can be called as follows:

```
loadStyleString("body{background-color:red}");
```

Styles specified in this way are added to the page instantly, so changes should be seen immediately.

NOTE *If you're coding for Internet Explorer specifically, be careful using `styleSheet.cssText`. If you reuse the same `<style>` element and try to set this property more than once, it has a tendency to crash the browser. Also, setting `cssText` to the empty string has the potential to crash the browser as well.*

Manipulating Tables

One of the most complex structures in HTML is the `<table>` element. Creating new tables typically means numerous tags for table rows, table cells, table headers, and so forth. Because of this complexity, using the core DOM methods to create and change tables can require a large amount of code.

Suppose you want to create the following HTML table using the DOM:

```
<table border="1" width="100%">
  <tbody>
    <tr>
      <td>Cell 1,1</td>
      <td>Cell 2,1</td>
    </tr>
    <tr>
      <td>Cell 1,2</td>
      <td>Cell 2,2</td>
    </tr>
  </tbody>
</table>
```

To accomplish this with the core DOM methods, the code would look something like this:

```
// create the table
let table = document.createElement("table");
table.border = 1;
table.width = "100%";

// create the tbody
let tbody = document.createElement("tbody");
table.appendChild(tbody);

// create the first row
let row1 = document.createElement("tr");
tbody.appendChild(row1);
let cell1_1 = document.createElement("td");
cell1_1.appendChild(document.createTextNode("Cell 1,1"));
row1.appendChild(cell1_1);
```



```
let cell2_1 = document.createElement("td");
cell2_1.appendChild(document.createTextNode("Cell 2,1"));
row1.appendChild(cell2_1);

// create the second row
let row2 = document.createElement("tr");
tbody.appendChild(row2);
let cell1_2 = document.createElement("td");
cell1_2.appendChild(document.createTextNode("Cell 1,2"));
row2.appendChild(cell1_2);
let cell2_2= document.createElement("td");
cell2_2.appendChild(document.createTextNode("Cell 2,2"));
row2.appendChild(cell2_2);

// add the table to the document body
document.body.appendChild(table);
```

This code is quite verbose and a little hard to follow. To facilitate building tables, the HTML DOM adds several properties and methods to the `<table>`, `<tbody>`, and `<tr>` elements.

The `<table>` element adds the following:

- `caption`—Pointer to the `<caption>` element (if it exists).
- `tBodies`—An `HTMLCollection` of `<tbody>` elements.
- `tFoot`—Pointer to the `<tfoot>` element (if it exists).
- `tHead`—Pointer to the `<thead>` element (if it exists).
- `rows`—An `HTMLCollection` of all rows in the table.
- `createTHead()`—Creates a `<thead>` element, places it into the table, and returns a reference.
- `createTFoot()`—Creates a `<tfoot>` element, places it into the table, and returns a reference.
- `createCaption()`—Creates a `<caption>` element, places it into the table, and returns a reference.
- `deleteTHead()`—Deletes the `<thead>` element.
- `deleteTFoot()`—Deletes the `<tfoot>` element.
- `deleteCaption()`—Deletes the `<caption>` element.
- `deleteRow(pos)`—Deletes the row in the given position.
- `insertRow(pos)`—Inserts a row in the given position in the `rows` collection.

The `<tbody>` element adds the following:

- `rows`—An `HTMLCollection` of rows in the `<tbody>` element.
- `deleteRow(pos)`—Deletes the row in the given position.
- `insertRow(pos)`—Inserts a row in the given position in the `rows` collection and returns a reference to the new row.

The `<tr>` element adds the following:

- `cells`—An `HTMLCollection` of cells in the `<tr>` element.
- `deleteCell(pos)`—Deletes the cell in the given position.
- `insertCell(pos)`—Inserts a cell in the given position in the `cells` collection and returns a reference to the new cell.

These properties and methods can greatly reduce the amount of code necessary to create a table. For example, the previous code can be rewritten using these methods as follows (the highlighted code is updated):

```
// create the table
let table = document.createElement("table");
table.border = 1;
table.width = "100%";

// create the tbody
let tbody = document.createElement("tbody");
table.appendChild(tbody);

// create the first row
tbody.insertRow(0);
tbody.rows[0].insertCell(0);
tbody.rows[0].cells[0].appendChild(document.createTextNode("Cell 1,1"));
tbody.rows[0].insertCell(1);
tbody.rows[0].cells[1].appendChild(document.createTextNode("Cell 2,1"));

// create the second row
tbody.insertRow(1);
tbody.rows[1].insertCell(0);
tbody.rows[1].cells[0].appendChild(document.createTextNode("Cell 1,2"));
tbody.rows[1].insertCell(1);
tbody.rows[1].cells[1].appendChild(document.createTextNode("Cell 2,2"));

// add the table to the document body
document.body.appendChild(table);
```

In this code, the creation of the `<table>` and `<tbody>` elements remains the same. What has changed is the section creating the two rows, which now makes use of the HTML DOM table properties and methods. To create the first row, the `insertRow()` method is called on the `<tbody>` element with an argument of `0`, which indicates the position in which the row should be placed. After that point, the row can be referenced by `tbody.rows[0]` because it is automatically created and added into the `<tbody>` element in position `0`.

Creating a cell is done in a similar way—by calling `insertCell()` on the `<tr>` element and passing in the position in which the cell should be placed. The cell can then be referenced by `tbody.rows[0].cells[0]` because the cell has been created and inserted into the row in position `0`.

Using these properties and methods to create a table makes the code much more logical and readable, although technically both sets of code are correct.

Using NodeLists

Understanding a `NodeList` object and its relatives, `NamedNodeMap` and `HTMLCollection`, is critical to a good understanding of the DOM as a whole. Each of these collections is considered “live,” which is to say that they are updated when the document structure changes such that they are always current with the most accurate information. In reality, all `NodeList` objects are queries that are run against the DOM document whenever they are accessed. For instance, the following results in an infinite loop:

```
let divs = document.getElementsByTagName("div");

for (let i = 0; i < divs.length; ++i){
  let div = document.createElement("div");
  document.body.appendChild(div);
}
```

The first part of this code gets an `HTMLCollection` of all `<div>` elements in the document. Because that collection is “live,” any time a new `<div>` element is added to the page, it gets added into the collection. Because the browser doesn’t want to keep a list of all the collections that were created, the collection is updated only when it is accessed again. This creates an interesting problem in terms of a loop such as the one in this example. Each time through the loop, the condition `i < divs.length` is being evaluated. That means the query to get all `<div>` elements is being run. Because the body of the loop creates a new `<div>` element and adds it to the document, the value of `divs.length` increments each time through the loop; thus `i` will never equal `divs.length` because both are being incremented.

Using an ES6 iterator doesn’t fix the situation because an ever-growing live collection remains the subject of iteration. This will still result in an infinite loop:

```
for (let div of document.getElementsByTagName("div")){
  let newDiv = document.createElement("div");
  document.body.appendChild(newDiv);
}
```

Any time you want to iterate over a `NodeList`, it’s best to initialize a second variable with the length and then compare the iterator to that variable, as shown in the following example:

```
let divs = document.getElementsByTagName("div");

for (let i = 0, len = divs.length; i < len; ++i) {
  let div = document.createElement("div");
  document.body.appendChild(div);
}
```

In this example, a second variable, `len`, is initialized. Because `len` contains a snapshot of `divs.length` at the time the loop began, it prevents the infinite loop that was experienced in the previous example. This technique has been used through this chapter to demonstrate the preferred way of iterating over `NodeList` objects.

Alternately, if you want to avoid having the second variable, you can also iterate the list in reverse:

```
let divs = document.getElementsByTagName("div");

for (let i = divs.length - 1; i >= 0; --i) {
```

```

    let div = document.createElement("div");
    document.body.appendChild(div);
  }

```

Generally speaking, it is best to limit the number of times you interact with a `NodeList`. Because a query is run against the document each time, try to cache frequently used values retrieved from a `NodeList`.

MUTATION OBSERVERS

The `MutationObserver` API, a relatively recent addition to the DOM specification, allows you to asynchronously execute a callback when the DOM is modified. With a `MutationObserver`, you are able to observe an entire document, a DOM subtree, or just a single element. Furthermore, you are also able to observe changes to element attributes, child nodes, text, or any combination of the three.

NOTE `MutationObservers` were introduced to replace the abandoned `Mutation Events` feature.

Basic usage

A `MutationObserver` instance is created by calling the `MutationObserver` constructor and passing a callback function:

```
let observer = new MutationObserver(() => console.log('DOM was mutated!'));
```

The `observe()` method

This instance begins unassociated with any part of the DOM. To link this observer with the DOM, the `observe()` method is used. This method accepts two required arguments: the target DOM node which is observed for changes, and the `MutationObserverInit` object.

The `MutationObserverInit` object is used to control what changes the observer should watch for. It takes the form of a dictionary of key/value configuration options. For example, the following code creates an observer and configures it to watch for attribute changes on the `body` element:

```
let observer = new MutationObserver(() => console.log('<body> attributes changed'));

observer.observe(document.body, { attributes: true });
```

At this point, any attribute changes to the `<body>` element will be detected by the `MutationObserver` instance, and the callback will asynchronously execute. Modifications to children or other non-attribute DOM mutations will not schedule a callback. This behavior is demonstrated here:

```
let observer = new MutationObserver(() => console.log('<body> attributes changed'));

observer.observe(document.body, { attributes: true });

document.body.className = 'foo';
console.log('Changed body class');

// Changed body class
// <body> attributes changed
```

Note that the callback `console.log` executes second, indicating that the callback does not synchronously execute with the actual DOM mutation.

Working with Callbacks and MutationRecords

Each callback is provided with an array of `MutationRecord` instances. Each instance contains information about what kind of mutation occurred and what part of the DOM was affected. Because it is possible that multiple qualifying mutations occurred before a callback is executed, each callback invocation is passed the queued backup of `MutationRecord` instances.

The `MutationRecord` array for a single attribute mutation is shown here:

```
let observer = new MutationObserver(
  (mutationRecords) => console.log(mutationRecords));

observer.observe(document.body, { attributes: true });

document.body.setAttribute('foo', 'bar');

// [
//   {
//     addedNodes: NodeList [],
//     attributeName: "foo",
//     attributeNamespace: null,
//     nextSibling: null,
//     oldValue: null,
//     previousSibling: null,
//     removedNodes: NodeList [],
//     target: body
//     type: "attributes"
//   }
// ]
```

A similar mutation involving a namespace is shown here:

```
let observer = new MutationObserver(
  (mutationRecords) => console.log(mutationRecords));

observer.observe(document.body, { attributes: true });

document.body.setAttributeNS('baz', 'foo', 'bar');

// [
//   {
//     addedNodes: NodeList [],
//     attributeName: "foo",
//     attributeNamespace: "baz",
//     nextSibling: null,
//     oldValue: null,
//     previousSibling: null,
//     removedNodes: NodeList [],
//     target: body
//     type: "attributes"
//   }
// ]
```

Sequential modifications will generate multiple `MutationRecord` instances, and the next callback invocation will be passed all the pending instances in the order they were enqueued:

```
let observer = new MutationObserver(
  (mutationRecords) => console.log(mutationRecords));

observer.observe(document.body, { attributes: true });

document.body.className = 'foo';
document.body.className = 'bar';
document.body.className = 'baz';

// [MutationRecord, MutationRecord, MutationRecord]
```

A `MutationRecord` instance will have the following properties:

KEY	VALUE
<code>target</code>	The node that was affected by the mutation.
<code>type</code>	A string indicating what type of mutation occurred. Can be "attributes", "characterData", or "childList".
<code>oldValue</code>	When enabled in the <code>MutationObserverInit</code> object, <code>attributes</code> or <code>characterData</code> mutations will set this field to the value that was replaced. This value is only provided when <code>attributeOldValue</code> or <code>characterDataOldValue</code> is <code>true</code> , otherwise this value is <code>null</code> . A <code>childList</code> mutation will always set this field to <code>null</code> .
<code>attributeName</code>	For <code>attributes</code> mutations, the string name of the attribute which was modified. For all other mutations, this field is set to <code>null</code> .
<code>attributeNamespace</code>	For <code>attributes</code> mutations which make use of namespaces, the string namespace of the attribute which was modified. For all other mutations, this field is set to <code>null</code> .
<code>addedNodes</code>	For <code>childList</code> mutations, returns a <code>NodeList</code> of nodes added in the mutation. Defaults to an empty <code>NodeList</code> .
<code>removedNodes</code>	For <code>childList</code> mutations, returns a <code>NodeList</code> of nodes removed in the mutation. Defaults to an empty <code>NodeList</code> .
<code>previousSibling</code>	For <code>childList</code> mutations, returns the previous sibling <code>Node</code> of the mutated node. Defaults to <code>null</code> .
<code>nextSibling</code>	For <code>childList</code> mutations, returns the next sibling <code>Node</code> of the mutated node. Defaults to <code>null</code> .

The second argument to the callback is the `MutationObserver` instance that detected the mutation, demonstrated here:

```
let observer = new MutationObserver(
  (mutationRecords, mutationObserver) => console.log(mutationRecords,
mutationObserver));

observer.observe(document.body, { attributes: true });

document.body.className = 'foo';

// [MutationRecord], MutationObserver
```

The `disconnect()` method

By default, a `MutationObserver` callback will execute for every DOM mutation in its designated purview until the element is garbage collected. To terminate callback execution early, the `disconnect()` method can be invoked. This example demonstrates how invoking `disconnect()` synchronously will halt callbacks, but will also discard any pending asynchronous callbacks, even if they were from a DOM mutation during the observation window:

```
let observer = new MutationObserver(() => console.log('<body> attributes changed'));

observer.observe(document.body, { attributes: true });

document.body.className = 'foo';

observer.disconnect();

document.body.className = 'bar';

// (nothing logged)
```

To allow for these queued callbacks to execute before invoking `disconnect()`, a `setTimeout` could be employed to allow for pending callbacks to execute:

```
let observer = new MutationObserver(() => console.log('<body> attributes changed'));

observer.observe(document.body, { attributes: true });

document.body.className = 'foo';

setTimeout(() => {
  observer.disconnect();
  document.body.className = 'bar';
}, 0);

// <body> attributes changed
```

Multiplexing a `MutationObserver`

A `MutationObserver` can be associated with many different target elements by calling `observe()` multiple times. The `target` property on the `MutationRecord` can identify which element was subject to that particular mutation. This behavior is demonstrated here:

```

let observer = new MutationObserver(
  (mutationRecords) => console.log(mutationRecords.map((x) =>
x.target)));

// Append two children to body
let childA = document.createElement('div'),
    childB = document.createElement('span');
document.body.appendChild(childA);
document.body.appendChild(childB);

// Observe both children
observer.observe(childA, { attributes: true });
observer.observe(childB, { attributes: true });

// Perform mutation on each child
childA.setAttribute('foo', 'bar');
childB.setAttribute('foo', 'bar');

// [<div>, <span>]

```

The `disconnect()` method is a blunt tool in that it will disconnect all observed nodes:

```

let observer = new MutationObserver(
  (mutationRecords) => console.log(mutationRecords.map((x) =>
x.target)));

// Append two children to body
let childA = document.createElement('div'),
    childB = document.createElement('span');
document.body.appendChild(childA);
document.body.appendChild(childB);

// Observe both children
observer.observe(childA, { attributes: true });
observer.observe(childB, { attributes: true });

observer.disconnect();

// Perform mutation on each child
childA.setAttribute('foo', 'bar');
childB.setAttribute('foo', 'bar');

// (nothing logged)

```

Reusing a MutationObserver

Invoking `disconnect()` is not an end-of-life event for a `MutationObserver`. The same instance can be reattached to a node. The following example demonstrates this behavior by disconnecting and then reconnecting in two consecutive async blocks:

```

let observer = new MutationObserver(() => console.log('<body> attributes
changed'));

observer.observe(document.body, { attributes: true });

```



```

// This will register as a mutation
document.body.setAttribute('foo', 'bar');

setTimeout(() => {
  observer.disconnect();

  // This will not register as a mutation
  document.body.setAttribute('bar', 'baz');
}, 0);

setTimeout(() => {
  // Reattach
  observer.observe(document.body, { attributes: true });

  // This will register as a mutation
  document.body.setAttribute('baz', 'qux');
}, 0);

// <body> attributes changed
// <body> attributes changed

```

Controlling the Observer scope with MutationObserverInit

The `MutationObserverInit` object is used to control which elements the observer should care about, and what kinds of changes to those elements it should care about. Broadly speaking, the observer can watch for attribute changes, text changes, or child node changes.

The following are the expected properties in the `MutationObserverInit` object:

KEY	VALUE
<code>subtree</code>	<p>Boolean indicating if the target element's node subtree should be watched in addition to the target element.</p> <p>When <code>false</code>, only the target element will be observed for designated mutations. When <code>true</code>, the target element and its entire node subtree will be watched for designated mutations.</p> <p>Defaults to <code>false</code>.</p>
<code>attributes</code>	<p>Boolean indicating if modifications to node attributes should register as a mutation.</p> <p>Defaults to <code>false</code>.</p>
<code>attributeFilter</code>	<p>Array of string values indicating which specific attributes should be observed for mutations.</p> <p>Setting this value to <code>true</code> will also coerce the value of <code>attributes</code> to <code>true</code>.</p> <p>Defaults to observing all attributes.</p>

KEY	VALUE
<code>attributeOldValue</code>	Boolean indicating if the character data prior to mutation should be recorded in the <code>MutationRecord</code> . Setting this value to an array will also coerce the value of <code>attributes</code> to <code>true</code> . Defaults to <code>false</code> .
<code>characterData</code>	Boolean indicating if modifications to character data should register as a mutation. Defaults to <code>false</code> .
<code>characterDataOldValue</code>	Boolean indicating if the character data prior to mutation should be recorded in the <code>MutationRecord</code> . Setting this value to <code>true</code> will also coerce the value of <code>characterData</code> to <code>true</code> . Defaults to <code>false</code> .
<code>childList</code>	Boolean indicating if modifications to the target node's child nodes should register as a mutation. Defaults to <code>false</code> .

NOTE When calling `observe()`, the `MutationObserverInit` object must specify at least one of `attributes`, `characterData`, or `childList` to be `true` (either explicitly or implicitly via an associated property such as `attributeOldValue`). Otherwise, an error will be thrown since there is no mutation that will trigger a callback to be invoked.

Observing attribute mutations

A `MutationObserver` is capable of registering when a node attribute is added, removed, or changed. Registering a callback is accomplished by setting the `attributes` property inside the `MutationObserverInit` object to `true`, as demonstrated here:

```
let observer = new MutationObserver(
  (mutationRecords) => console.log(mutationRecords));

observer.observe(document.body, { attributes: true });

// Add attribute
document.body.setAttribute('foo', 'bar');

// Modify existing attribute
document.body.setAttribute('foo', 'baz');
```

```
// Remove attribute
document.body.removeAttribute('foo');

// All three are recorded as mutations
// [MutationRecord, MutationRecord, MutationRecord]
```

The default behavior is to observe all attribute changes and to not record the old value inside the `MutationRecord`. If you desired to observe a subset of attributes, the `attributeFilter` property can be used as a whitelist of attribute names:

```
let observer = new MutationObserver(
  (mutationRecords) => console.log(mutationRecords));

observer.observe(document.body, { attributeFilter: ['foo'] });

// Add whitelisted attribute
document.body.setAttribute('foo', 'bar');

// Add excluded attribute
document.body.setAttribute('baz', 'qux');

// Only a single mutation record is created for the 'foo' attribute mutation
// [MutationRecord]
```

If you desired to preserve the old value inside the mutation record, the `attributeOldValue` can be set to `true`:

```
let observer = new MutationObserver(
  (mutationRecords) => console.log(mutationRecords.map((x) => x.oldValue)));

observer.observe(document.body, { attributeOldValue: true });

document.body.setAttribute('foo', 'bar');
document.body.setAttribute('foo', 'baz');
document.body.setAttribute('foo', 'qux');

// Each mutation records the previous value
// [null, 'bar', 'baz']
```

Observing character data mutations

A `MutationObserver` is capable of registering when a textual node (such as `Text`, `Comment`, or `ProcessingInstruction` nodes) has its character data added, removed, or changed. This is accomplished by setting the `characterData` property inside the `MutationObserverInit` object to `true`, as demonstrated here:

```
let observer = new MutationObserver(
  (mutationRecords) => console.log(mutationRecords));

// Create an initial text node to observe
document.body.innerHTML = 'foo';

observer.observe(document.body.firstChild, { characterData: true });

// Identical string assignment
document.body.innerHTML = 'foo';
```

```
// New string assignment
document.body.innerText = 'bar';

// Node setter assignment
document.body.firstChild.textContent = 'baz';

// All three are recorded as mutations
// [MutationRecord, MutationRecord, MutationRecord]
```

The default behavior is to not record the old value inside the `MutationRecord`. If you desired to preserve the old value inside the mutation record, the `attributeOldValue` can be set to `true`:

```
let observer = new MutationObserver(
  (mutationRecords) => console.log(mutationRecords.map((x) => x.oldValue)));
document.body.innerText = 'foo';

observer.observe(document.body.firstChild, { characterDataOldValue: true });

document.body.innerText = 'foo';
document.body.innerText = 'bar';
document.body.firstChild.textContent = 'baz';

// Each mutation records the previous value
// ["foo", "foo", "bar"]
```

Observing child mutations

A `MutationObserver` is capable of registering when an element has a child node added or removed. This is accomplished by setting the `childList` property inside the `MutationObserverInit` object to `true`.

A child node addition is demonstrated here:

```
// clear body
document.body.innerHTML = '';

let observer = new MutationObserver(
  (mutationRecords) => console.log(mutationRecords));

observer.observe(document.body, { childList: true });

document.body.appendChild(document.createElement('div'));

// [
//   {
//     addedNodes: NodeList[div],
//     attributeName: null,
//     attributeNamespace: null,
//     oldValue: null,
//     nextSibling: null,
//     previousSibling: null,
//     removedNodes: NodeList[],
//     target: body,
//     type: "childList",
//   }
// ]
```

A child node removal is demonstrated here:

```
// clear body
document.body.innerHTML = '';

let observer = new MutationObserver(
  (mutationRecords) => console.log(mutationRecords));

observer.observe(document.body, { childList: true });

document.body.appendChild(document.createElement('div'));

// [
//   {
//     addedNodes: NodeList[],
//     attributeName: null,
//     attributeNamespace: null,
//     oldValue: null,
//     nextSibling: null,
//     previousSibling: null,
//     removedNodes: NodeList[div],
//     target: body,
//     type: "childList",
//   }
// ]
```

A child *reordering*, although it can be performed with a single method, will register as two separate mutations since it is technically a node removal and subsequent re-addition:

```
// clear body
document.body.innerHTML = '';

let observer = new MutationObserver(
  (mutationRecords) => console.log(mutationRecords));

// Create two initial children
document.body.appendChild(document.createElement('div'));
document.body.appendChild(document.createElement('span'));

observer.observe(document.body, { childList: true });

// Reorder children
document.body.insertBefore(document.body.lastChild, document.body.firstChild);

// Two mutations are registered: 0-index record is removal, 1-index record
// is addition
// [
//   {
//     addedNodes: NodeList[],
//     attributeName: null,
//     attributeNamespace: null,
//     oldValue: null,
//     nextSibling: null,
//     previousSibling: div,
//     removedNodes: NodeList[span],
//     target: body,
//   }
// ]
```

```

//   type: childList,
// },
// {
//   addedNodes: NodeList[span],
//   attributeName: null,
//   attributeNamespace: null,
//   oldValue: null,
//   nextSibling: div,
//   previousSibling: null,
//   removedNodes: NodeList[],
//   target: body,
//   type: "childList",
// }
// ]

```

Observing subtree mutations

By default, the `MutationObserver` is scoped to only observe modifications to a single element and its child node list. This scope can be expanded to the entirety of its DOM subtree by setting the `subtree` property inside the `MutationObserverInit` object to `true`.

Watching a subtree for attribute mutations can be accomplished in the following fashion:

```

// clear body
document.body.innerHTML = '';

let observer = new MutationObserver(
  (mutationRecords) => console.log(mutationRecords));

// Create initial element
document.body.appendChild(document.createElement('div'));

// Observe the <body> subtree
observer.observe(document.body, { attributes: true, subtree: true });

// Modify <body> subtree
document.body.firstChild.setAttribute('foo', 'bar');

// Subtree modification registers as mutation
// [
//   {
//     addedNodes: NodeList[],
//     attributeName: "foo",
//     attributeNamespace: null,
//     oldValue: null,
//     nextSibling: null,
//     previousSibling: null,
//     removedNodes: NodeList[],
//     target: div,
//     type: "attributes",
//   }
// ]

```

Interestingly, the subtree designation of a node will persist even when that node is moved out of the observed tree. This means that after a subtree node leaves that specific subtree, mutations which are now technically outside the observed subtree will still register as qualified mutations.

This behavior is demonstrated here:

```
// clear body
document.body.innerHTML = '';

let observer = new MutationObserver(
  (mutationRecords) => console.log(mutationRecords));

let subtreeRoot = document.createElement('div'),
    subtreeLeaf = document.createElement('span');

// Create initial subtree of height 2
document.body.appendChild(subtreeRoot);
subtreeRoot.appendChild(subtreeLeaf);

// Observe the subtree
observer.observe(subtreeRoot, { attributes: true, subtree: true });

// Move node in subtree outside of observed subtree
document.body.insertBefore(subtreeLeaf, subtreeRoot);

subtreeLeaf.setAttribute('foo', 'bar');

// subtree modification still registers as mutation
// [MutationRecord]
```

Async Callbacks and the Record Queue

The `MutationObserver` specification is designed for performance, and at the core of its design is the asynchronous callback and record queue model. To allow for a large number of mutations to be registered without degrading performance, information about each qualifying mutation (determined by the observer instance) is captured in a `MutationRecord` and then enqueued on a *record queue*. This queue is unique to each `MutationObserver` instance and represents an in-order record of each DOM mutation.

Behavior of the Record Queue

Each time a `MutationRecord` is added to a `MutationObserver`'s record queue, the observer callback (initially provided to the `MutationObserver` constructor) is scheduled as a microtask only if there is no callback microtask already scheduled, for example the queue length is > 0 . This ensures there is no dual-callback processing of the record queue's contents.

It is possible that, by the time the callback's microtask asynchronously executes, more mutations have occurred than the one which initially scheduled the callback microtask. The invoked callback is passed an array of `MutationRecord` instances as they appear in the record queue. The callback is responsible for fully handling each instance in the array, as they will not persist after the function exits. Following the callback execution, it is expected that each `MutationRecord` is no longer needed, so the record queue is emptied and its contents discarded.

The takeRecords() method

It is possible to drain a `MutationObserver` instance's record queue with the `takeRecords()` method. This will return the array of `MutationRecord` instances which exist in the queue, and empty the queue itself. This is demonstrated here:

```
let observer = new MutationObserver(
  (mutationRecords) => console.log(mutationRecords));

observer.observe(document.body, { attributes: true });

document.body.className = 'foo';
document.body.className = 'bar';
document.body.className = 'baz';

console.log(observer.takeRecords());
console.log(observer.takeRecords());

// [MutationRecord, MutationRecord, MutationRecord]
// []
```

This is useful when you would like to call `disconnect()` but wish to handle all pending `MutationRecord` instances in the queue which are discarded by calling `disconnect()`.

Performance, Memory, and Garbage Collection

The `MutationEvent`, introduced in the DOM Level 2 specification, defined a handful of events which were fired upon various DOM mutations. In implementation, because of the nature of events in the browser, this specification led to substantial performance problems, and in the DOM Level 3 specification these events were deprecated. The `MutationObserver` was introduced to replace these with a more pragmatic and performant design.

Delegating execution of mutation callbacks to a microtask ensures that the synchronous nature of events and the messiness that accompanies them was avoided. The record queue implementation for the `MutationObserver` specification ensures that even a preponderance of mutation events will not unduly bog down the browser.

Nevertheless, using a `MutationObserver` will still incur *some* overhead, and it is important to understand where this overhead will manifest.

MutationObserver References

The reference relationship between a `MutationObserver` and the node (or nodes) it observes is asymmetric. A `MutationObserver` has a weak reference to the target node it is observing. Because this reference is weak, it will not prevent the target node from being garbage collected.

However, a node has a strong reference to its `MutationObserver`. If the target node is removed from the DOM and subsequently garbage collected, the associated `MutationObserver` is also garbage collected.

MutationRecord References

Each `MutationRecord` instance in the record queue will contain at least one reference to an existing DOM node; in the case of a `childNodes` mutation, it will contain many references. The default behavior of the record queue and callback processing is to drain the queue, process each `MutationRecord`, and allow them to go out of scope and be garbage collected.

There may be a situation where it is useful to preserve a full record of mutations from a given observer. Preserving each `MutationRecord` instance will also preserve the node references it contains, thereby preventing the nodes from being garbage collected. If prompt node garbage collection is needed, prefer to extract the minimum required information from each `MutationRecord` into a new object, and discard the `MutationRecord`.

SUMMARY

The Document Object Model (DOM) is a language-independent API for accessing and manipulating HTML and XML documents. DOM Level 1 deals with representing HTML and XML documents as a hierarchy of nodes that can be manipulated to change the appearance and structure of the underlying documents using JavaScript.

The DOM is made up of a series of node types, as described here:

- The base node type is `Node`, which is an abstract representation of an individual part of a document; all other types inherit from `Node`.
- The `Document` type represents an entire document and is the root node of a hierarchy. In JavaScript, the `document` object is an instance of `Document`, which allows for querying and retrieval of nodes in a number of different ways.
- An `Element` node represents all HTML or XML elements in a document and can be used to manipulate their contents and attributes.
- Other node types exist for text contents, comments, document types, the CDATA section, and document fragments.

DOM access works as expected in most cases, although there are often complications when working with `<script>` and `<style>` elements. Because these elements contain scripting and stylistic information, respectively, they are often treated differently in browsers than other elements.

Perhaps the most important thing to understand about the DOM is how it affects overall performance. DOM manipulations are some of the most expensive operations that can be done in JavaScript, with `NodeList` objects being particularly troublesome. `NodeList` objects are “live,” meaning that a query is run every time the object is accessed. Because of these issues, it is best to minimize the number of DOM manipulations.

The `MutationObserver` was introduced to replace the less-performant `MutationEvent`. It allows for efficient and precise DOM mutation monitoring with a relatively simple API.

15

DOM Extensions

WHAT'S IN THIS CHAPTER?

- ▶ Understanding the Selectors API
- ▶ Using HTML5 DOM extensions

WROX.COM DOWNLOADS FOR THIS CHAPTER

Please note that all the code examples for this chapter are available as a part of this chapter's code download on the book's website at www.wrox.com/go/projavascript4e on the Download Code tab.

Even though the DOM is a fairly well-defined API, it is also frequently augmented with both standards-based and proprietary extensions to provide additional functionality. Prior to 2008, almost all of the DOM extensions found in browsers were proprietary. After that point, the W3C went to work to codify some of the proprietary extensions that had become de facto standards into formal specifications.

The two primary standards specifying DOM extensions are the Selectors API and HTML5. These both arose out of needs in the development community and a desire to standardize certain approaches and APIs. There is also a smaller Element Traversal specification with additional DOM properties. Proprietary extensions still exist, even though these two specifications, especially HTML5, cover a large number of DOM extensions. The proprietary extensions are also covered in this chapter.

All content in this chapter is supported by all major browsers meaning all vendor releases that have meaningful web traffic—unless otherwise stated.

SELECTORS API

One of the most popular capabilities of JavaScript libraries is the ability to retrieve a number of DOM elements matching a pattern specified using CSS selectors. Indeed, the library jQuery (www.jquery.com) is built completely around the CSS selector queries of a DOM document in order to retrieve references to elements instead of using `getElementById()` and `getElementsByName()`.

The Selectors API (www.w3.org/TR/selectors-api) was started by the W3C to specify native support for CSS queries in browsers. All JavaScript libraries implementing this feature had to do so by writing a rudimentary CSS parser and then using existing DOM methods to navigate the document and identify matching nodes. Although library developers worked tirelessly to speed up the performance of such processing, there was only so much that could be done while the code ran in JavaScript. By making this a native API, the parsing and tree navigating can be done at the browser level in a compiled language and thus tremendously increase the performance of such functionality.

At the core of Selectors API Level 1 are two methods: `querySelector()` and `querySelectorAll()`. On a conforming browser, these methods are available on the `Document` type and on the `Element` type.

The Selectors API Level 2 specification (<https://www.w3.org/TR/selectors-api2/>) introduces more methods: `matches()`, `find()`, and `findAll()` on the `Element` type, although no browsers currently have or have stated an intention to support `find()`, or `findAll()`.

The `querySelector()` Method

The `querySelector()` method accepts a CSS query and returns the first descendant element that matches the pattern or `null` if there is no matching element. Here is an example:

```
// Get the body element
let body = document.querySelector("body");

// Get the element with the ID "myDiv"
let myDiv = document.querySelector("#myDiv");

// Get first element with a class of "selected"
let selected = document.querySelector(".selected");

// Get first image with class of "button"
let img = document.body.querySelector("img.button");
```

When the `querySelector()` method is used on the `Document` type, it starts trying to match the pattern from the document element; when used on an `Element` type, the query attempts to make a match from the descendants of the element only.

The CSS query may be as complex or as simple as necessary. If there's a syntax error or an unsupported selector in the query, then `querySelector()` throws an error.

The `querySelectorAll()` Method

The `querySelectorAll()` method accepts the same single argument as `querySelector()`—the CSS query—but returns all matching nodes instead of just one. This method returns a static instance of `NodeList`.

To clarify, the return value is actually a `NodeList` with all of the expected properties and methods, but its underlying implementation acts as a snapshot of elements rather than a dynamic query that is constantly reexecuted against a document. This implementation eliminates most of the performance overhead associated with the use of `NodeList` objects.

Any call to `querySelectorAll()` with a valid CSS query will return a `NodeList` object regardless of the number of matching elements; if there are no matches, the `NodeList` is empty.

As with `querySelector()`, the `querySelectorAll()` method is available on the `Document`, `DocumentFragment`, and `Element` types. Here are some examples:

```
// Get all <em> elements in a <div> (similar to getElementsByTagName("em"))
let ems = document.getElementById("myDiv").querySelectorAll("em");

// Get all elements wthat have "selected" as a class
let selecteds = document.querySelectorAll(".selected");

// Get all <strong> elements inside of <p> elements
let strongs = document.querySelectorAll("p strong");
```

The resulting `NodeList` object may be iterated over using iteration hooks, `item()`, or bracket notation to retrieve individual elements. Here's an example:

```
let strongElements = document.querySelectorAll("p strong");
// All three of the following loops will have the same effect:

for (let strong of strongElements) {
  strong.className = "important";
}

for (let i = 0; i < strongElements.length; ++i) {
  strongElements.item(i).className = "important";
}

for (let i = 0; i < strongElements.length; ++i) {
  strongElements [i].className = "important";
}
```

As with `querySelector()`, `querySelectorAll()` throws an error when the CSS selector is not supported by the browser or if there's a syntax error in the selector.

The matches() Method

`matches()` was formerly referred to as `matchesSelector()` in the specification draft. This method accepts a single argument, a CSS selector, and returns `true` if the given element matches the selector or `false` if not. For example:

```
if (document.body.matches("body.page1")) {
  // true
}
```

This method allows you to easily check if an element would be returned by `querySelector()` or `querySelectorAll()` when you already have the element reference.

All major browsers support some form of `matches()`. Edge, Chrome, Firefox, Safari, and Opera fully support it; IE 9–11 and minor mobile browsers support it with vendor prefixes.

ELEMENT TRAVERSAL

Prior to version 9, Internet Explorer did not return text nodes for white space in between elements while all of the other browsers did. This led to differences in behavior when using properties such as `childNodes` and `firstChild`. In an effort to equalize the differences while still remaining true to the DOM specification, a new group of properties was defined in the Element Traversal (www.w3.org/TR/ElementTraversal/).

The Element Traversal API adds five new properties to DOM elements:

- `childElementCount`—Returns the number of child elements (excludes text nodes and comments).
- `firstElementChild`—Points to the first child that is an element. Element-only version of `firstChild`.
- `lastElementChild`—Points to the last child that is an element. Element-only version of `lastChild`.
- `previousElementSibling`—Points to the previous sibling that is an element. Element-only version of `previousSibling`.
- `nextElementSibling`—Points to the next sibling that is an element. Element-only version of `nextSibling`.

Supporting browsers add these properties to all DOM elements to allow for easier traversal of DOM elements without the need to worry about white space text nodes.

For example, iterating over all child elements of a particular element in a traditional cross-browser way looks like this:

```
let parentElement = document.getElementById('parent');
let currentChildNode = parentElement.firstChild;

// For zero children, firstChild returns null and the loop is skipped
while (currentChildNode) {
  if (currentChildNode.nodeType === 1) {
    // If this is an ELEMENT_NODE, do whatever work is needed in here
    processChild(currentChildNode);
  }
  if (currentChildNode === parentElement.lastChild) {
    break;
  }
  currentChildNode = currentChildNode.nextSibling;
}
```

Using the Element Traversal properties allows a simplification of the code:

```
let parentElement = document.getElementById('parent');
let currentChildElement = parentElement.firstElementChild;

// For zero children, firstElementChild returns null and the loop is skipped
while (currentChildElement) {
  // You already know this is an ELEMENT_NODE, do whatever work is needed here
  processChild(currentChildElement);
}
```

```
if (currentChildElement === parentElement.lastElementChild) {
    break;
}
currentChildElement = currentChildElement.nextElementSibling;
}
```

Element Traversal is implemented in Internet Explorer 9+ and all modern browsers.

HTML5

HTML5 represents a radical departure from the tradition of HTML. In all previous HTML specifications, the descriptions stopped short of describing any JavaScript interfaces, instead focusing purely on the markup of the language and deferring JavaScript bindings to the DOM specification.

The HTML5 specification, on the other hand, contains a large amount of JavaScript APIs designed for use with the markup additions. Part of these APIs overlap with the DOM and define DOM extensions that browsers should provide.

NOTE *Because the scope of HTML5 is vast, this section focuses only on the parts that affect all DOM nodes. Other parts of HTML5 are discussed in their related topics throughout the book.*

Class-Related Additions

One of the major changes in web development since the time HTML4 was adopted is the increased usage of the `class` attribute to indicate both stylistic and semantic information about elements. This caused a lot of JavaScript interaction with CSS classes, including the dynamic changing of classes and querying the document to find elements with a given class or set of classes. To adapt to developers and their newfound appreciation of the `class` attribute, HTML5 introduces a number of changes to make CSS class usage easier.

The `getElementsByClassName()` Method

One of HTML5's most popular additions is `getElementsByClassName()`, which is available on the `document` object and on all HTML elements. This method evolved out of JavaScript libraries that implemented it using existing DOM features and is provided as a native implementation for performance reasons.

The `getElementsByClassName()` method accepts a single argument, which is a string containing one or more class names, and returns a `NodeList` containing all elements that have all of the specified classes applied. If multiple class names are specified, then the order is considered unimportant. Here are some examples:

```
// Get all elements with a class containing "username" and "current"
// It does not matter if one is declared before the other
let allCurrentUsernames = document.getElementsByClassName("username current");
```

```
// Get all elements with a class of "selected" that exist in myDiv's subtree
let selected = document.getElementById("myDiv").getElementsByClassName("selected");
```

When this method is called, it will return only elements in the subtree of the root from which it was called. Calling `getElementsByClassName()` on `document` always returns all elements with matching class names, whereas calling it on an element will return only descendant elements.

This method is useful for attaching events to classes of elements rather than using IDs or tag names. Keep in mind that since the returned value is a `NodeList`, there are the same performance issues as when you're using `getElementsByTagName()` and other DOM methods that return `NodeList` objects.

The `getElementsByClassName()` method is implemented in Internet Explorer 9+ and all modern browsers.

The classList Property

In class name manipulation, the `className` property is used to add, remove, and replace class names. Because `className` contains a single string, it's necessary to set its value every time a change needs to take place, even if there are parts of the string that should be unaffected. For example, consider the following HTML code:

```
<div class="bd user disabled">...</div>
```

This `<div>` element has three classes assigned. To remove one of these classes, you need to split the `class` attribute into individual classes, remove the unwanted class, and then create a string containing the remaining classes. Here is an example:

```
// Remove the "user" class
let targetClass = "user";

// First, get list of class names
let classNames = div.className.split(/\s+/);

// Find the class name to remove
let idx = classNames.indexOf(targetClass);

// Remove the class name if found
if (idx > -1) {
  classNames.splice(i,1);
}

// Set back the class name
div.className = classNames.join(" ");
```

All of this code is necessary to remove the "user" class from the `<div>` element's `class` attribute. A similar algorithm must be used for replacing class names and detecting if a class name is applied to an element. Adding class names can be done by using string concatenation, but checks must be done to ensure that you're not applying the same class more than one time. Many JavaScript libraries implement methods to aid in these behaviors.

HTML5 introduces a way to manipulate class names in a much simpler and safer manner through the addition of the `classList` property for all elements. The `classList` property is an instance of a

new type of collection named `DOMTokenList`. As with other DOM collections, `DOMTokenList` has a `length` property to indicate how many items it contains, and individual items may be retrieved via the `item()` method or using bracket notation. It also has the following additional methods:

- `add(value)`—Adds the given string value to the list. If the value already exists, it will not be added.
- `contains(value)`—Indicates if the given value exists in the list (`true` if so; `false` if not).
- `remove(value)`—Removes the given string value from the list.
- `toggle(value)`—If the value already exists in the list, it is removed. If the value doesn't exist, then it's added.

The entire block of code in the previous example can quite simply be replaced with the following:

```
div.classList.remove("user");
```

Using this code ensures that the rest of the class names will be unaffected by the change. The other methods also greatly reduce the complexity of the basic operations, as shown in these examples:

```
// Remove the "disabled" class
div.classList.remove("disabled");

// Add the "current" class
div.classList.add("current");

// Toggle the "user" class
div.classList.toggle("user");

// Figure out what's on the element now
if (div.classList.contains("bd") && !div.classList.contains("disabled")){
  // Do stuff
}

// Iterate over the class names
for (let class of div.classList){
  doStuff(class);
}
```

The addition of the `classList` property makes it unnecessary to access the `className` property unless you intend to completely remove or completely overwrite the element's `class` attribute. The `classList` property is implemented partially in Internet Explorer 10+ and fully in all other major browsers.

Focus Management

HTML5 adds functionality to aid with focus management in the DOM. The first is `document.activeElement`, which always contains a pointer to the DOM element that currently has focus. An element can receive focus automatically as the page is loading, via user input (typically using the Tab key), or programmatically using the `focus()` method. For example:

```
let button = document.getElementById("myButton");
button.focus();
console.log(document.activeElement === button); // true
```

By default, `document.activeElement` is set to `document.body` when the document is first loaded. Before the document is fully loaded, `document.activeElement` is `null`.

The second addition is `document.hasFocus()`, which returns a Boolean value indicating if the document has focus:

```
let button = document.getElementById("myButton");
button.focus();
console.log(document.hasFocus()); // true
```

Determining if the document has focus allows you to determine if the user is interacting with the page.

This combination of being able to query the document to determine which element has focus and being able to ask the document if it has focus is of the utmost importance for web application accessibility. One of the key components of accessible web applications is proper focus management, and being able to determine which elements currently have focus is a major improvement over the guesswork of the past.

Changes to HTMLDocument

HTML5 extends the `HTMLDocument` type to include more functionality. As with other DOM extensions specified in HTML5, the changes are based on proprietary extensions that are well-supported across browsers. As such, even though the standardization of the extensions is relatively new, some browsers have supported the functionality for a while.

The readyState Property

Internet Explorer 4 was the first to introduce a `readyState` property on the `document` object, and it is supported by all modern browsers. Other browsers then followed suit and this property was eventually formalized in HTML5. The `readyState` property for `document` has two possible values:

- `loading`—The document is loading.
- `complete`—The document is completely loaded.

The best way to use the `document.readyState` property is as an indicator that the document has loaded. Before this property was widely available, you would need to add an `onload` event handler to set a flag indicating that the document was loaded. Basic usage:

```
if (document.readyState == "complete"){
    // Do stuff
}
```

Compatibility Mode

With the introduction of Internet Explorer 6 and the ability to render a document in either standards or quirks mode, it became necessary to determine in which mode the browser was rendering the page. Internet Explorer added a property on the `document` named `compatMode` whose sole job is to indicate

what rendering mode the browser is in. As shown in the following example, when in standards mode, `document.compatMode` is equal to `"CSS1Compat"`; when in quirks mode, `document.compatMode` is `"BackCompat"`:

```
if (document.compatMode == "CSS1Compat") {
  console.log("Standards mode");
} else {
  console.log("Quirks mode");
}
```

The `compatMode` property was added to HTML5 to formalize its implementation.

The head Property

HTML5 introduces `document.head` to point to the `<head>` element of a document to complement `document.body`, which points to the `<body>` element of the document. You can retrieve a reference to the `<head>` element using this property:

```
let head = document.head;
```

Character Set Properties

HTML5 describes several new properties dealing with the character set of the document. The `characterSet` property indicates the actual character set being used by the document and can also be used to specify a new character set. By default, this value is `"UTF-16"`, although it may be changed by using `<meta>` elements or response headers or through setting the `characterSet` property directly. Here's an example:

```
console.log(document.characterSet); // "UTF-16"
document.characterSet = "UTF-8";
```

Custom Data Attributes

HTML5 allows elements to be specified with nonstandard attributes prefixed with `data-` in order to provide information that isn't necessary to the rendering or semantic value of the element. These attributes can be added as desired and named anything, provided that the name begins with `data-`. Here is an example:

```
<div id="myDiv" data-appId="12345" data-myname="Nicholas"></div>
```

When a custom data attribute is defined, it can be accessed via the `dataset` property of the element. The `dataset` property contains an instance of `DOMStringMap` that is a mapping of name-value pairs. Each attribute of the format `data-name` is represented by a property with a name equivalent to the attribute but without the `data-` prefix (for example, attribute `data-myname` is represented by a property called `myname`). The following is an example of how to use custom data attributes:

```
// Methods used in this example are for illustrative purposes only

let div = document.getElementById("myDiv");
```

```
// Get the values
let appId = div.dataset.appId;
let myName = div.dataset.myname;

// Set the value
div.dataset.appId = 23456;
div.dataset.myname = "Michael";

// Is there a "myname" value?
if (div.dataset.myname) {
  console.log('Hello, ${div.dataset.myname}');
}
```

Custom data attributes are useful when nonvisual data needs to be tied to an element for some other form of processing. This is a common technique to use for link tracking and mashups in order to better identify parts of a page. It is also extensively utilized in numerous single-page application frameworks.

Markup Insertion

Although the DOM provides fine-grained control over nodes in a document, it can be cumbersome when attempting to inject a large amount of new HTML into the document. Instead of creating a series of DOM nodes and connecting them in the correct order, it's much easier (and faster) to use one of the markup insertion capabilities to inject a string of HTML. The following DOM extensions have been standardized in HTML5 for this purpose.

The innerHTML Property

When used in read mode, `innerHTML` returns the HTML representing all of the child nodes, including elements, comments, and text nodes. When used in write mode, `innerHTML` completely replaces all of the child nodes in the element with a new DOM subtree based on the specified value. Consider the following HTML code:

```
<div id="content">
  <p>This is a <strong>paragraph</strong> with a list following it.</p>
  <ul>
    <li>Item 1</li>
    <li>Item 2</li>
    <li>Item 3</li>
  </ul>
</div>
```

For the `<div>` element in this example, the `innerHTML` property returns the following string:

```
<p>This is a <strong>paragraph</strong> with a list following it.</p>
<ul>
  <li>Item 1</li>
  <li>Item 2</li>
  <li>Item 3</li>
</ul>
```

The exact text returned from `innerHTML` differs from browser to browser. Internet Explorer and Opera tend to convert all tags to uppercase, whereas Safari, Chrome, and Firefox return HTML in

the way it is specified in the document, including white space and indentation. You cannot depend on the returned value of `innerHTML` being exactly the same from browser to browser.

When used in write mode, `innerHTML` parses the given string into a DOM subtree and replaces all of the existing child nodes with it. Because the string is considered to be HTML, all tags are converted into elements in the standard way that the browser handles HTML (again, this differs from browser to browser). Setting simple text without any HTML tags, as shown here, sets the plain text:

```
div.innerHTML = "Hello world!";
```

Setting `innerHTML` to a string containing HTML behaves quite differently as `innerHTML` parses them. Consider the following example:

```
div.innerHTML = "Hello & welcome, <b>\"reader\"!</b>";
```

The result of this operation is as follows:

```
<div id="content">Hello &amp; welcome, <b>&quot;reader&quot;!</b></div>
```

After setting `innerHTML`, you can access the newly created nodes as you would any other nodes in the document.

NOTE *Setting `innerHTML` causes the HTML string to be parsed by the browser into an appropriate DOM tree. This means that setting `innerHTML` and then reading it back typically results in a different string being returned. This is because the returned string is the result of serializing the DOM subtree that was created for the original HTML string.*

Using innerHTML in Legacy Internet Explorer

`<script>` elements cannot be executed when inserted via `innerHTML` in all modern browsers. Internet Explorer 8 and earlier, is the only browser that allows this but only as long as the `defer` attribute is specified and the `<script>` element is preceded by what Microsoft calls a *scoped element*. The `<script>` element is considered a *NoScope element*, which effectively means that it has no visual representation on the page, like a `<style>` element or a comment. Internet Explorer strips out all NoScope elements from the beginning of strings inserted via `innerHTML`, which means the following won't work:

```
// Won't work
div.innerHTML = "<script defer>console.log('hi');</script>";
```

In this case, the `innerHTML` string begins with a NoScope element, so the entire string becomes empty. To allow this script to work appropriately, you must precede it with a scoped element, such as a text node or an element without a closing tag such as `<input>`. The following lines will all work:

```
// All these will work
div.innerHTML = "_<script defer>console.log('hi');</script>";
div.innerHTML = "<div>&nbsp;</div><script defer>console.log('hi');</script>";
div.innerHTML = "<input type=\"hidden\"><script defer>console.log('hi');</script>";
```

The first line results in a text node being inserted immediately before the `<script>` element. You may need to remove this after the fact so as not to disrupt the flow of the page. The second line has a similar approach, using a `<div>` element with a nonbreaking space. An empty `<div>` alone won't do the trick; it must contain some content that will force a text node to be created. Once again, the first node may need to be removed to avoid layout issues. The third line uses a hidden `<input>` field to accomplish the same thing. Because it doesn't affect the layout of the page, this may be the optimal case for most situations.

In most browsers, the `<style>` element causes similar problems with `innerHTML`. Most browsers support the insertion of `<style>` elements using `innerHTML` in the exact way you'd expect, as shown here:

```
div.innerHTML = "<style type=\"text/css\">body {background-color: red; }</style>";
```

In Internet Explorer 8 and earlier, `<style>` is yet another NoScope element, so it must be preceded by a scoped element such as this:

```
div.innerHTML = "_<style type=\"text/css\">body {background-color: red; }</style>";
div.removeChild(div.firstChild);
```

NOTE *Firefox's support of `innerHTML` is stricter in XHTML documents served with the `application/xhtml+xml` content type. When using `innerHTML` in XHTML documents, you must specify well-formed XHTML code. If the code is not well formed, setting `innerHTML` fails silently.*

The outerHTML Property

When `outerHTML` is called in read mode, it returns the HTML of the element on which it is called, as well as its child nodes. When called in write mode, `outerHTML` replaces the node on which it is called with the DOM subtree created from parsing the given HTML string. Consider the following HTML code:

```
<div id="content">
  <p>This is a <strong>paragraph</strong> with a list following it.</p>
  <ul>
    <li>Item 1</li>
    <li>Item 2</li>
    <li>Item 3</li>
  </ul>
</div>
```

When `outerHTML` is called on the `<div>` in this example, the same code is returned, including the code for the `<div>`. Note that there may be differences based on how the browser parses and interprets the HTML code. (These are the same types of differences you'll notice when using `innerHTML`.)

Use `outerHTML` to set a value in the following manner:

```
div.outerHTML = "<p>This is a paragraph.</p>";
```

This code performs the same operation as the following DOM code:

```
let p = document.createElement("p");
p.appendChild(document.createTextNode("This is a paragraph."));
div.parentNode.replaceChild(p, div);
```

The new `<p>` element replaces the original `<div>` element in the DOM tree.

The insertAdjacentHTML() and insertAdjacentText() Methods

The last addition for markup insertion is the `insertAdjacentHTML()` and `insertAdjacentText()` methods. These methods also originated in Internet Explorer and accept two arguments: the position in which to insert and the HTML or text to insert. The first argument must be one of the following values:

- "beforebegin"—Insert just before the element as a previous sibling.
- "afterbegin"—Insert just inside of the element as a new child or series of children before the first child.
- "beforeend"—Insert just inside of the element as a new child or series of children after the last child.
- "afterend"—Insert just after the element as a next sibling.

Note that each of these values is case insensitive. The second argument is parsed as an HTML string (the same as with `innerHTML/outerHTML`) or as a raw string (the same as with `innerText/outerText`) and in the case of HTML, will throw an error if the value cannot be properly parsed. Basic usage is as follows:

```
// Insert as previous sibling
element.insertAdjacentHTML("beforebegin", "<p>Hello world!</p>");
element.insertAdjacentText("beforebegin", "Hello world!");

// Insert as first child
element.insertAdjacentHTML("afterbegin", "<p>Hello world!</p>");
element.insertAdjacentText("afterbegin", "Hello world!");

// Insert as last child
element.insertAdjacentHTML("beforeend", "<p>Hello world!</p>");
element.insertAdjacentText("beforeend", "Hello world!");

// Insert as next sibling
element.insertAdjacentHTML("afterend", "<p>Hello world!</p>"); element.
insertAdjacentText("afterend", "Hello world!");
```

Memory and Performance Issues

Replacing child nodes using the methods in this section may cause memory problems in browsers, especially Internet Explorer. The problem occurs when event handlers or other JavaScript objects are assigned to subtree elements that are removed. If an element has an event handler (or a JavaScript object as a property), and one of these properties is used in such a way that the element is removed from the document tree, the binding between the element and the event handler remains in memory. If this is repeated frequently, memory usage increases for the page. When using `innerHTML`, `outerHTML`, and `insertAdjacentHTML()`, it's best to manually remove all event handlers and JavaScript object properties on elements that are going to be removed.

Using these properties does have an upside, especially when using `innerHTML`. Generally speaking, inserting a large amount of new HTML is more efficient through `innerHTML` than through multiple DOM operations to create nodes and assign relationships between them. This is because an HTML parser is created whenever a value is set to `innerHTML` (or `outerHTML`). This parser runs in browser-level code (often written in C++), which is much faster than JavaScript. That being said, the creation and destruction of the HTML parser does have some overhead, so it's best to limit the number of times you set `innerHTML` or `outerHTML`. For example, the following creates a number of list items using `innerHTML`:

```
for (let value of values){
  ul.innerHTML += '<li>${value}</li>'; // avoid!!
}
```

This code is inefficient because it sets `innerHTML` once each time through the loop. Furthermore, this code is reading `innerHTML` each time through the loop, meaning that `innerHTML` is being accessed twice each time through the loop. It's best to build up the string separately and assign it using `innerHTML` just once at the end, like this:

```
let itemsHtml = "";
for (let value of values){
  itemsHtml += '<li>${value}</li>';
}
ul.innerHTML = itemsHtml;
```

This example is more efficient, limiting the use of `innerHTML` to one assignment. Of course, if you wanted to condense it to a single line:

```
ul.innerHTML = values.map(value => '<li>${value}</li>').join('');
```

Cross-Site Scripting Considerations

Although `innerHTML` does not execute script tags that it creates, it still provides an extremely broad attack surface for malicious actors looking to compromise a web page because it so readily creates elements and executable attributes such as `onclick`.

Anywhere you are interpolating user-provided information into the page, it is nearly always inadvisable to do so using `innerHTML`. The headaches of preventing XSS vulnerabilities far outweigh any convenience benefits gained from using `innerHTML`. Compartmentalize interpolated data, and don't hesitate to use libraries that escape interpolated data before inserting them into the page.

The `scrollIntoView()` Method

One of the issues not addressed by the DOM specification is how to scroll areas of a page. To fill this gap, browsers implemented several methods that control scrolling in different ways. Of the various proprietary methods, only `scrollIntoView()` was selected for inclusion in HTML5.

The `scrollIntoView()` method exists on all HTML elements and scrolls the browser window or container element so the element is visible in the viewport.

- If an argument of `true` is supplied, it specifies `alignToTop`: The window scrolls so that the top of the element is at the top of the viewport.
- If an argument of `false` is supplied, it specifies `alignToTop`: The window scrolls so that the bottom of the element is at the top of the viewport.

- If an object argument is supplied, the user can provide values for the `behavior` property, which specifies how the scroll should occur: `auto`, `instant`, or `smooth` (limited support outside of Firefox), and the `block` property is the same as `alignToTop`.
- If no argument is supplied, the element is scrolled so that it is fully visible in the viewport but may not be aligned at the top. For example:

```
// Ensures this element is visible
document.forms[0].scrollIntoView();

// These behave identically
document.forms[0].scrollIntoView(true);
document.forms[0].scrollIntoView({block: true});

// This attempts to scroll the element smoothly into view:
document.forms[0].scrollIntoView({behavior: 'smooth', block: true});
```

This method is most useful for getting the user’s attention when something has happened on the page. Note that setting focus to an element also causes the browser to scroll the element into view so that the focus can properly be displayed.

PROPRIETARY EXTENSIONS

Although all browser vendors understand the importance of adherence to standards, they all have a history of adding proprietary extensions to the DOM in order to fill perceived gaps in functionality. Though this may seem like a bad thing on the surface, proprietary extensions have given the web development community many important features that were later codified into standards such as HTML5.

There are still a large amount of DOM extensions that are proprietary in nature and haven’t been incorporated into standards. This doesn’t mean that they won’t later be adopted as standards—just that at the time of this writing, they remain proprietary and adopted by only a subset of browsers.

The children Property

The differences in how Internet Explorer prior to version 9 and other browsers interpret white space in text nodes led to the creation of the `children` property. The `children` property is an `HTMLCollection` that contains only an element’s child nodes that are also elements. Otherwise, the `children` property is the same as `childNodes` and may contain the same items when an element has only elements as children. The `children` property is accessed as follows:

```
let childCount = element.children.length;
let firstChild = element.children[0];
```

The contains() Method

It’s often necessary to determine if a given node is a descendant of another. Internet Explorer first introduced the `contains()` method as a way of providing this information without necessitating a walk up the DOM document tree. The `contains()` method is called on the ancestor node from which the search should begin and accepts a single argument, which is the suspected descendant node.

If the node exists as a descendant of the root node, the method returns `true`; otherwise it returns `false`. Here is an example:

```
console.log(document.documentElement.contains(document.body)); // true
```

This example tests to see if the `<body>` element is a descendant of the `<html>` element, which returns `true` in all well-formed HTML pages.

There is another way of determining node relationships by using the DOM Level 3 `compareDocumentPosition()` method. This method determines the relationship between two nodes and returns a bitmask indicating the relationship. The values for the bitmask are as shown in the following table.

MASK	RELATIONSHIP BETWEEN NODES
0x1	Disconnected (The passed-in node is not in the document.)
0x2	Precedes (The passed-in node appears in the DOM tree prior to the reference node.)
0x4	Follows (The passed-in node appears in the DOM tree after the reference node.)
0x8	Contains (The passed-in node is an ancestor of the reference node.)
0x10	Is contained by (The passed-in node is a descendant of the reference node.)

To mimic the `contains()` method, you will be interested in the 16 mask. The result of `compareDocumentPosition()` can be bitwise ANDed to determine if the reference node contains the given node. Here is an example:

```
let result = document.documentElement.compareDocumentPosition(document.body);
console.log(!!(result & 0x10));
```

When this code is executed, `result` becomes 20, or 0x14 (0x4 for “follows” plus 0x10 for “is contained by”). Applying a bitwise mask of 0x10 to the result returns a nonzero number, and the two NOT bang operators convert that value into a Boolean.

IE9+ and all modern browsers support both `contains` and `compareDocumentPosition`.

Markup Insertion

While the `innerHTML` and `outerHTML` markup insertion properties were adopted by HTML5 from Internet Explorer, there are two others that were not. The two remaining properties that are left out of HTML5 are `innerText` and `outerText`.

The innerText Property

The `innerText` property works with all text content contained within an element, regardless of how deep in the subtree the text exists. When used to read the value, `innerText` concatenates the values of all text nodes in the subtree in depth-first order. When used to write the value, `innerText` removes all children of the element and inserts a text node containing the given value. Consider the following HTML code:

```
<div id="content">
  <p>This is a <strong>paragraph</strong> with a list following it.</p>
```

```

<ul>
  <li>Item 1</li>
  <li>Item 2</li>
  <li>Item 3</li>
</ul>
</div>

```

For the `<div>` element in this example, the `innerText` property returns the following string:

```

This is a paragraph with a list following it.
Item 1
Item 2
Item 3

```

Note that different browsers treat white space in different ways, so the formatting may or may not include the indentation in the original HTML code.

Using the `innerText` property to set the contents of the `<div>` element is as simple as this single line of code:

```
div.innerText = "Hello world!";
```

After executing this line of code, the HTML of the page is effectively changed to the following:

```
<div id="content">Hello world!</div>
```

Setting `innerText` removes all of the child nodes that existed before, completely changing the DOM subtree. Additionally, setting `innerText` encodes all HTML syntax characters (less-than, greater-than, quotation marks, and ampersands) that may appear in the text. Here is an example:

```
div.innerText = "Hello & welcome, <b>\\"reader\\"!</b>";
```

The result of this operation is as follows:

```
<div id="content">Hello &amp; welcome, &lt;b&gt;&quot;reader&quot;!&lt;/b&gt;&lt;/div>
```

Setting `innerText` can never result in anything other than a single text node as the child of the container, so the HTML-encoding of the text must take place in order to keep to that single text node. The `innerText` property is also useful for stripping out HTML tags. By setting the `innerText` equal to the `innerText`, as shown here, all HTML tags are removed:

```
div.innerText = div.innerText;
```

Executing this code replaces the contents of the container with just the text that exists already.

NOTE For Firefox versions prior to 45 (released March 2016), the only method supported was `textContent`. This was similar to `innerText`, the only difference being that while `innerText` skips over inline style and script blocks, `textContent` returns any inline style or script code along with other text. `innerText` is now supported across all browsers and should be the primary tool for getting and setting text content.

The `outerText` Property

The `outerText` property works in the same way as `innerText` except that it includes the node on which it's called. For reading text values, `outerText` and `innerText` essentially behave in the exact same way. In writing mode, however, `outerText` behaves very differently. Instead of replacing just the child nodes of the element on which it's used, `outerText` actually replaces the entire element, including its child nodes. Consider the following:

```
div.outerText = "Hello world!";
```

This single line of code is equivalent to the following two lines:

```
let text = document.createTextNode("Hello world!");
div.parentNode.replaceChild(text, div);
```

Essentially, the new text node completely replaces the element on which `outerText` was set. After that point in time, the element is no longer in the document and cannot be accessed.

The `outerText` property is nonstandard, and not on a standards track. It is not recommended that you rely on it for important behavior. It is supported in all modern browsers except for Firefox.

Scrolling

As mentioned previously, scrolling is one area where specifications didn't exist prior to HTML5. While `scrollIntoView()` was standardized in HTML5, there are still several additional proprietary methods available in various browsers. `scrollIntoViewIfNeeded` exists as an extension to the `HTMLElement` type and therefore each is available on all elements. `scrollIntoViewIfNeeded(alignCenter)` scrolls the browser window or container element so that the element is visible in the viewport only if it's not already visible; if the element is already visible in the viewport, this method does nothing. The optional *alignCenter* argument will attempt to place the element in the center of the viewport if set to `true`. This is implemented in Safari, Chrome, and Opera.

Following is an example of how this may be used:

```
// Make sure this element is visible only if it's not already
document.images[0].scrollIntoViewIfNeeded();
```

Because `scrollIntoView()` is the only method supported in all browsers, this is typically the only one used.

SUMMARY

While the DOM specifies the core API for interacting with XML and HTML documents, there are several specifications that provide extensions to the standard DOM. Many of the extensions are based on proprietary extensions that later became de facto standards as other browsers began to mimic their functionality. The three specifications covered in this chapter are:

- **Selectors API**, which defines two methods for retrieving DOM elements based on CSS selectors: `querySelector()`, `querySelectorAll()`, and `matches()`.

- **Element Traversal**, which defines additional properties on DOM elements to allow easy traversal to the next related DOM element. The need for this arose because of the handling of white space in the DOM that creates text nodes between elements.
- **HTML5**, which provides a large number of extensions to the standard DOM. These include standardization of de facto standards such as `innerHTML`, as well as additional functionality for dealing with focus management, character sets, scrolling, and more.

The number of DOM extensions is currently small, but it's almost a certainty that the number will continue to grow as web technology continues to evolve. Browsers still experiment with proprietary extensions that, if successful, may end up as pseudo-standards or be incorporated into future versions' specifications.

16

DOM Levels 2 and 3

WHAT'S IN THIS CHAPTER?

- Changes to the DOM introduced in Levels 2 and 3
- The DOM API for manipulating styles
- Working with DOM traversal and ranges

The first level of the DOM focuses on defining the underlying structure of HTML and XML documents. DOM Levels 2 and 3 build on this structure to introduce more interactivity and support for more advanced XML features. As a result, DOM Levels 2 and 3 actually consist of several modules that, although related, describe very specific subsets of the DOM. These modules are as follows:

- **DOM Core**—Builds on the Level 1 core, adding methods and properties to nodes.
- **DOM Views**—Defines different views for a document based on stylistic information.
- **DOM Events**—Explains how to tie interactivity to DOM documents using events.
- **DOM Style**—Defines how to programmatically access and change CSS styling information.
- **DOM Traversal and Range**—Introduces new interfaces for traversing a DOM document and selecting specific parts of it.
- **DOM HTML**—Builds on the Level 1 HTML, adding properties, methods, and new interfaces.
- **DOM Mutation Observers**—Allows for definition of callbacks upon changes to the DOM. Mutation Observers were defined in the DOM4 specification to replace Mutation Events.

This chapter explores each of these modules except for DOM events and DOM mutation observers, which are covered fully in the Document Object Model chapter. DOM Level 3 also contains the XPath module and the Load and Save module. These are discussed in the XML in JavaScript chapter.

NOTE *Very old browser versions such as Internet Explorer 8 have limited support for some of the content in this chapter. If you're looking to support these browsers, it is recommended that you thoroughly investigate browser support before making use of these APIs. <https://caniuse.com> is an excellent tool for this type of research.*

DOM CHANGES

The purpose of the DOM Levels 2 and 3 Core is to expand the DOM API to encompass all of the requirements of XML and to provide for better error handling and feature detection. For the most part, this means supporting the concept of XML namespaces. DOM Level 2 Core doesn't introduce any new types; it simply augments the types defined in DOM Level 1 to include new methods and properties. DOM Level 3 Core further augments the existing types and introduces several new ones.

Similarly, DOM Views and HTML augment DOM interfaces, providing new properties and methods. These two modules are fairly small and so are grouped in with the Core to discuss changes to fundamental JavaScript objects.

NOTE *This chapter covers only the parts of the DOM that have been implemented by browsers; parts that have yet to be implemented by any browser are not mentioned.*

XML Namespaces

XML namespaces allow elements from different XML-based languages to be mixed together in a single, well-formed document without fear of element name clashes. Technically, XML namespaces are not supported by HTML but supported in XHTML; therefore, the examples in this section are in XHTML.

Namespaces are specified using the `xmlns` attribute. The namespace for XHTML is `http://www.w3.org/1999/xhtml` and should be included on the `<html>` element of any well-formed XHTML page, as shown in the following example:

```
<html xmlns="http://www.w3.org/1999/xhtml">
  <head>
    <title>Example XHTML page</title>
  </head>
  <body>
    Hello world!
  </body>
</html>
```

For this example, all elements are considered to be part of the XHTML namespace by default. You can explicitly create a prefix for an XML namespace using `xmlns`, followed by a colon, followed by the prefix, as in this example:

```
<xhtml:html xmlns:xhtml="http://www.w3.org/1999/xhtml">
  <xhtml:head>
    <xhtml:title>Example XHTML page</xhtml:title>
  </xhtml:head>
  <xhtml:body>
    Hello world!
  </xhtml:body>
</xhtml:html>
```

Here, the namespace for XHTML is defined with a prefix of `xhtml`, requiring all XHTML elements to begin with that prefix. Attributes may also be namespaced to avoid confusion between languages, as shown in the following example:

```
<xhtml:html xmlns:xhtml="http://www.w3.org/1999/xhtml">
  <xhtml:head>
    <xhtml:title>Example XHTML page</xhtml:title>
  </xhtml:head>
  <xhtml:body xhtml:class="home">
    Hello world!
  </xhtml:body>
</xhtml:html>
```

The `class` attribute in this example is prefixed with `xhtml`. Namespacing isn't really necessary when only one XML-based language is being used in a document; it is, however, very useful when mixing two languages together. Consider the following document containing both XHTML and SVG:

```
<html xmlns="http://www.w3.org/1999/xhtml">
  <head>
    <title>Example XHTML page</title>
  </head>
  <body>
    <svg xmlns="http://www.w3.org/2000/svg" version="1.1"
      viewBox="0 0 100 100" style="width:100%; height:100%">
      <rect x="0" y="0" width="100" height="100" style="fill:red" />
    </svg>
  </body>
</html>
```

In this example, the `<svg>` element is indicated as foreign to the containing document by setting its own namespace. All children of the `<svg>` element, as well as all attributes of the elements, are considered to be in the `http://www.w3.org/2000/svg` namespace. Even though the document is technically an XHTML document, the SVG code is considered valid because of the use of namespaces.

The interesting problem with a document such as this is what happens when a method is called on the document to interact with nodes in the document. When a new element is created, which namespace does it belong to? When querying for a specific tag name, what namespaces should be included in the results? DOM Level 2 Core answers these questions by providing namespace-specific versions of most DOM Level 1 methods.

Changes to Node

The `Node` type evolves in DOM Level 2 to include the following namespace-specific properties:

- `localName`—The node name without the namespace prefix.
- `namespaceURI`—The namespace URI of the node or `null` if not specified.
- `prefix`—The namespace prefix or `null` if not specified.

When a node uses a namespace prefix, the `nodeName` is equivalent to `prefix + ":" + localName`. Consider the following example:

```
<html xmlns="http://www.w3.org/1999/xhtml">
  <head>
    <title>Example XHTML page</title>
  </head>
  <body>
    <s:svg xmlns:s="http://www.w3.org/2000/svg" version="1.1"
      viewBox="0 0 100 100" style="width:100%; height:100%">
      <s:rect x="0" y="0" width="100" height="100" style="fill:red" />
    </s:svg>
  </body>
</html>
```

For the `<html>` element, the `localName` and `tagName` is `"html"`, the `namespaceURI` is `"http://www.w3.org/1999/xhtml"`, and the `prefix` is `null`. For the `<s:svg>` element, the `localName` is `"svg"`, the `tagName` is `"s:svg"`, the `namespaceURI` is `"http://www.w3.org/2000/svg"`, and the `prefix` is `"s"`.

DOM Level 3 goes one step further and introduces the following methods to work with namespaces:

- `isDefaultNamespace(namespaceURI)`—Returns `true` when the specified `namespaceURI` is the default namespace for the node.
- `lookupNamespaceURI(prefix)`—Returns the namespace URI for the given `prefix`.
- `lookupPrefix(namespaceURI)`—Returns the prefix for the given `namespaceURI`.

In the previous example, the following code can be executed:

```
console.log(document.body.isDefaultNamespace("http://www.w3.org/1999/
  xhtml")); // true

// assume svg contains a reference to <s:svg>
console.log(svg.lookupPrefix("http://www.w3.org/2000/svg")); // "s"
console.log(svg.lookupNamespaceURI("s")); // "http://www.w3.org/2000/svg"
```

These methods are primarily useful when you have a reference to a node without knowing its relationship to the rest of the document.

Changes to Document

The `Document` type is changed in DOM Level 2 to include the following namespace-specific methods:

- `createElementNS(namespaceURI, tagName)`—Creates a new element with the given *tagName* as part of the namespace indicated by *namespaceURI*.
- `createAttributeNS(namespaceURI, attributeName)`—Creates a new attribute node as part of the namespace indicated by *namespaceURI*.
- `getElementsByTagNameNS(namespaceURI, tagName)`—Returns a `NodeList` of elements with the given *tagName* that are also a part of the namespace indicated by *namespaceURI*.

These methods are used by passing in the namespace URI of the namespace to use (not the namespace prefix), as shown in the following example.

```
// create a new SVG element
let svg = document.createElementNS("http://www.w3.org/2000/svg", "svg");

// create new attribute for a random namespace
let att = document.createAttributeNS("http://www.somewhere.com", "random");

// get all XHTML elements
let elems = document.getElementsByTagNameNS("http://www.w3.org/1999/xhtml", "*");
```

The namespace-specific methods are necessary only when there are two or more namespaces in a given document.

Changes to Element

The changes to `Element` in DOM Level 2 Core are mostly related to attributes. The following new methods are introduced:

- `getAttributeNS(namespaceURI, localName)`—Gets the attribute from the namespace represented by *namespaceURI* and with a name of *localName*.
- `getAttributeNodeNS(namespaceURI, localName)`—Gets the attribute node from the namespace represented by *namespaceURI* and with a name of *localName*.
- `getElementsByTagNameNS(namespaceURI, tagName)`—Returns a `NodeList` of descendant elements with the given *tagName* that are also a part of the namespace indicated by *namespaceURI*.
- `hasAttributeNS(namespaceURI, localName)`—Determines if the element has an attribute from the namespace represented by *namespaceURI* and with a name of *localName*. Note: DOM Level 2 Core also adds a `hasAttribute()` method for use without namespaces.
- `removeAttributeNS(namespaceURI, localName)`—Removes the attribute from the namespace represented by *namespaceURI* and with a name of *localName*.

- `setAttributeNS(namespaceURI, qualifiedName, value)`—Sets the attribute from the namespace represented by `namespaceURI` and with a name of `qualifiedName` equal to `value`.
- `setAttributeNodeNS(attNode)`—Sets the attribute node from the namespace represented by `namespaceURI`.

These methods behave the same as their DOM Level 1 counterparts with the exception of the first argument, which is always the namespace URI except for `setAttributeNodeNS()`.

Changes to NamedNodeMap

The `NamedNodeMap` type also introduces the following methods for dealing with namespaces. Because attributes are represented by a `NamedNodeMap`, these methods mostly apply to attributes.

- `getNamedItemNS(namespaceURI, localName)`—Gets the item from the namespace represented by `namespaceURI` and with a name of `localName`.
- `removeNamedItemNS(namespaceURI, localName)`—Removes the item from the namespace represented by `namespaceURI` and with a name of `localName`.
- `setNamedItemNS(node)`—Adds `node`, which should have namespace information already applied.

These methods are rarely used because attributes are typically accessed directly from an element.

Other Changes

There are some other minor changes made to various parts of the DOM in DOM Level 2 Core. These changes don't have to do with XML namespaces and are targeted more toward ensuring the robustness and completeness of the API.

Changes to DocumentType

The `DocumentType` type adds three new properties: `publicId`, `systemId`, and `internalSubset`. The `publicId` and `systemId` properties represent data that is readily available in a doctype but were inaccessible using DOM Level 1. Consider the following HTML doctype:

```
<!DOCTYPE HTML PUBLIC "-// W3C// DTD HTML 4.01// EN"  
    "http://www.w3.org/TR/html4/strict.dtd">
```

In this doctype, the `publicId` is `"-// W3C// DTD HTML 4.01// EN"` and the `systemId` is `"http://www.w3.org/TR/html4/strict.dtd"`. Browsers that support DOM Level 2 should be able to run the following JavaScript code:

```
console.log(document.doctype.publicId);  
console.log(document.doctype.systemId);
```

Accessing this information is rarely, if ever, needed in web pages.

The `internalSubset` property accesses any additional definitions that are included in the doctype, as shown in the following example:

```
<!DOCTYPE html PUBLIC "-// W3C// DTD XHTML 1.0 Strict// EN"
"http://www.w3.org/TR/xhtml1/DTD/xhtml1-strict.dtd"
[<!ELEMENT name (#PCDATA)>] >
```

For this code, `document.doctype.internalSubset` returns "`<!ELEMENT name (#PCDATA)>`". Internal subsets are rarely used in HTML and are slightly more common in XML.

Changes to Document

The only new method on `Document` that is not related to namespaces is `importNode()`. The purpose of this method is to take a node from a different document and import it into a new document so that it can be added into the document structure. Remember that every node has an `ownerDocument` property that indicates the document it belongs to. If a method such as `appendChild()` is called and a node with a different `ownerDocument` is passed in, an error will occur. Calling `importNode()` on a node from a different document returns a new version of the node that is owned by the appropriate document.

The `importNode()` method is similar to the `cloneNode()` method on an element. It accepts two arguments: the node to clone and a Boolean value indicating if the child nodes should also be copied. The result is a duplicate of the node that is suitable for use in the document. Here is an example:

```
let newNode = document.importNode(oldNode, true); // import node and all children
document.body.appendChild(newNode);
```

This method isn't used very often with HTML documents; it is used more frequently with XML documents (discussed further in the XML in JavaScript chapter).

DOM Level 2 Views adds a property called `defaultView`, which is a pointer to the window (or frame) that owns the given document. The Views specification doesn't provide details about when other views may be available, so this is the only property added. The `defaultView` property is supported in all browsers (except Internet Explorer 8 and earlier). There is an equivalent property called `parentWindow` that is supported in Internet Explorer 8 and earlier, as well as Opera. Thus, to determine the owning window of a document, you can use the following code:

```
let parentWindow = document.defaultView || document.parentWindow;
```

Aside from this one method and property, there are a couple of changes to the `document.implementation` object specified in the DOM Level 2 Core in the form of two new methods: `createDocumentType()` and `createDocument()`. The `createDocumentType()` method is used to create new `DocumentType` nodes and accepts three arguments: the name of the doctype, the `publicId`, and the `systemId`. For example, the following code creates a new HTML 4.01 Strict doctype:

```
let doctype = document.implementation.createDocumentType("html",
"-// W3C// DTD HTML 4.01// EN",
"http://www.w3.org/TR/html4/strict.dtd");
```

An existing document's doctype cannot be changed, so `createDocumentType()` is useful only when creating new documents, which can be done with `createDocument()`. This method accepts three

arguments: the `namespaceURI` for the document element, the tag name of the document element, and the doctype for the new document. A new blank XML document can be created, as shown in the following example:

```
let doc = document.implementation.createDocument("", "root", null);
```

This code creates a new document with no namespace and a document element of `<root>` with no doctype specified. To create an XHTML document, you can use the following code:

```
let doctype = document.implementation.createDocumentType("html",
    "-// W3C// DTD XHTML 1.0 Strict// EN",
    "http://www.w3.org/TR/xhtml1/DTD/xhtml1-strict.dtd");

let doc = document.implementation.createDocument("http://www.w3.org/1999/xhtml",
    "html", doctype);
```

Here, a new XHTML document is created with the appropriate namespace and doctype. The document has only the document element `<html>`; everything else must be added.

The DOM Level 2 HTML module also adds a method called `createHTMLDocument()` to `document.implementation`. The purpose of this method is to create a complete HTML document, including the `<html>`, `<head>`, `<title>`, and `<body>` elements. This method accepts a single argument, which is the title of the newly created document (the string to go in the `<title>` element), and returns the new HTML document as follows:

```
let htmldoc = document.implementation.createHTMLDocument("New Doc");
console.log(htmldoc.title); // "New Doc"
console.log(typeof htmldoc.body); // "object"
```

The object created from a call to `createHTMLDocument()` is an instance of the `HTMLDocument` type and so contains all of the properties and methods associated with it, including the `title` and `body` properties.

Changes to Node

DOM Level 3 introduces two methods to help compare nodes: `isSameNode()` and `isEqualNode()`. Both methods accept a single node as an argument and return `true` if that node is the same as or equal to the reference node. Two nodes are the same when they reference the same object. Two nodes are equal when they are of the same type and have properties that are equal (`nodeName`, `nodeValue`, and so on), and their `attributes` and `childNodes` properties are equivalent (containing equivalent values in the same positions). Here is an example:

```
let div1 = document.createElement("div");
div1.setAttribute("class", "box");

let div2 = document.createElement("div");
div2.setAttribute("class", "box");

console.log(div1.isSameNode(div1)); // true
console.log(div1.isEqualNode(div2)); // true
console.log(div1.isSameNode(div2)); // false
```

Here, two `<div>` elements are created with the same attributes. The two elements are equivalent to one another but are not the same.

DOM Level 3 also introduces methods for attaching additional data to DOM nodes. The `setUserData()` method assigns data to a node and accepts three arguments: the key to set, the actual data (which may be of any data type), and a handler function. You can assign data to a node using the following code:

```
document.body.setUserData("name", "Nicholas", function() {});
```

You can then retrieve the information using `getUserData()` and passing in the same key, as shown here:

```
let value = document.body.getUserData("name");
```

The handler function for `setUserData()` is called whenever the node with the data is cloned, removed, renamed, or imported into another document and gives you the opportunity to determine what should happen to the user data in each of those cases. The handler function accepts five arguments: a number indicating the type of operation (1 for clone, 2 for import, 3 for delete, or 4 for rename), the data key, the data value, the source node, and the destination node. The source node is `null` when the node is being deleted, and the destination node is `null` unless the node is being cloned. You can then determine how to store the data. Here is an example:

```
let div = document.createElement("div");
div.setUserData("name", "Nicholas", function(operation, key, value, src, dest) {
  if (operation == 1) {
    dest.setUserData(key, value, function() {}); }
});

let newDiv = div.cloneNode(true);
console.log(newDiv.getUserData("name")); // "Nicholas"
```

Here, a `<div>` element is created and has some data assigned to it, including some user data. When the element is cloned via `cloneNode()`, the handler function is called and the data is automatically assigned to the clone. When `getUserData()` is called on the clone, it returns the same value that was assigned to the original.

Changes to iframes

Iframes, represented by `HTMLIFrameElement` have a new property in DOM Level 2 HTML called `contentDocument`. This property contains a pointer to the document object representing the contents of the iframe. This property can be used, as shown in the following example:

```
let iframe = document.getElementById("myIframe");
let iframeDoc = iframe.contentDocument;
```

The `contentDocument` property is an instance of `Document` and can be used just like any other HTML document, including all properties and methods. There is also a property called `contentWindow` that returns the window object for the frame, which has a `document` property. The `contentDocument` and `contentWindow` properties are available in all modern browsers.

NOTE Access to the document object of an iframe is limited based on cross-domain security restrictions. If you are attempting to access the document object of an iframe containing a page that is loaded from a different domain or subdomain, or with a different protocol, doing so will throw an error.

STYLES

Styles are defined in HTML in three ways: including an external style sheet via the `<link>` element, defining inline styles using the `<style>` element, and defining element-specific styles using the `style` attribute. DOM Level 2 Style provides an API around all three of these styling mechanisms.

Accessing Element Styles

Any HTML element that supports the `style` attribute also has a `style` property exposed in JavaScript. The `style` object is an instance of `CSSStyleDeclaration` and contains all stylistic information specified by the HTML `style` attribute but no information about styles that have cascaded from either included or inline style sheets. Any CSS property specified in the `style` attribute are represented as properties on the `style` object. Because CSS property names use dash case (using dashes to separate words, such as `background-image`), the names must be converted into camel case in order to be used in JavaScript. The following table lists some common CSS properties and the equivalent property names on the `style` object.

CSS PROPERTY	JAVASCRIPT PROPERTY
<code>background-image</code>	<code>style.backgroundImage</code>
<code>color</code>	<code>style.color</code>
<code>display</code>	<code>style.display</code>
<code>font-family</code>	<code>style.fontFamily</code>

For the most part, property names convert directly simply by changing the format of the property name. The one CSS property that doesn't translate directly is `float`. Because `float` is a reserved word in JavaScript, it can't be used as a property name. The DOM Level 2 Style specification states that the corresponding property on the `style` object should be `cssFloat`.

Styles can be set using JavaScript at any time as long as a valid DOM element reference is available. Here are some examples:

```
let myDiv = document.getElementById("myDiv");

// set the background color
myDiv.style.backgroundColor = "red";

// change the dimensions
myDiv.style.width = "100px";
myDiv.style.height = "200px";

// assign a border
myDiv.style.border = "1px solid black";
```

When styles are changed in this manner, the display of the element is automatically updated.

NOTE *When in standards mode, all measurements have to include a unit of measure. In quirks mode, you can set `style.width` to be "20" and it will assume that you mean "20px"; in standards mode, setting `style.width` to "20" will be ignored because it has no unit of measure. In practice, it's best to always include the unit of measurement.*

Styles specified in the `style` attribute can also be retrieved using the `style` object. Consider the following HTML:

```
<div id="myDiv" style="background-color: blue; width: 10px; height: 25px"></div>
```

The information from this element's `style` attribute can be retrieved via the following code:

```
console.log(myDiv.style.backgroundColor); // "blue"
console.log(myDiv.style.width);         // "10px"
console.log(myDiv.style.height);        // "25px"
```

If no `style` attribute is specified on an element, the `style` object will contain empty values for all possible CSS properties.

DOM Style Properties and Methods

The DOM Level 2 Style specification also defines several properties and methods on the `style` object. These properties and methods provide information about the contents of the element's `style` attribute and enabling changes. They are as follows:

- `cssText`—As described previously, `cssText` provides access to the CSS code of the `style` attribute.
- `length`—The number of CSS properties applied to the element.
- `parentRule`—The `CSSRule` object representing the CSS information. The `CSSRule` type is discussed in a later section.
- `getPropertyCSSValue(propertyName)`—Returns a `CSSValue` object containing the value of the given property.
- `getPropertyPriority(propertyName)`—Returns "important" if the given property is set using !important; otherwise, it returns an empty string.
- `getPropertyValue(propertyName)`—Returns the string value of the given property.
- `item(index)`—Returns the name of the CSS property at the given position.
- `removeProperty(propertyName)`—Removes the given property from the style.
- `setProperty(propertyName, value, priority)`—Sets the given property to the given value with a priority (either "important" or an empty string).

The `cssText` property allows access to the CSS code of the style. When used in read mode, `cssText` returns the browser's internal representation of the CSS code in the `style` attribute. When used in

write mode, the value assigned to `cssText` overwrites the entire value of the `style` attribute, meaning that all previous style information specified using the attribute is lost. For instance, if the element has a border specified via the `style` attribute and you overwrite `cssText` with rules that don't include the border, it is removed from the element. The `cssText` property is used as follows:

```
myDiv.style.cssText = "width: 25px; height: 100px; background-color: green";
console.log(myDiv.style.cssText);
```

Setting the `cssText` property is the fastest way to make multiple changes to an element's style because all of the changes are applied at once.

The `length` property is designed for use in conjunction with the `item()` method for iterating over the CSS properties defined on an element. With these, the `style` object effectively becomes a collection, and bracket notation can be used in place of `item()` to retrieve the CSS property name in the given position, as shown in the following example:

```
for (let i = 0, len = myDiv.style.length; i < len; i++) {
  console.log(myDiv.style[i]); // alternately, myDiv.style.item(i)
}
```

Using either bracket notation or `item()`, you can retrieve the CSS property name ("background-color", not "backgroundColor"). This property name can then be used in `getPropertyValue()` to retrieve the actual value of the property, as shown in the following example:

```
let prop, value, i, len;
for (i = 0, len = myDiv.style.length; i < len; i++) {
  prop = myDiv.style[i]; // alternately, myDiv.style.item(i)
  value = myDiv.style.getPropertyValue(prop);
  console.log('prop: ${value}');
}
```

The `getPropertyValue()` method always retrieves the string representation of the CSS property value. If you need more information, `getPropertyCSSValue()` returns a `CSSValue` object that has two properties: `cssText` and `cssValueType`. The `cssText` property is the same as the value returned from `getPropertyValue()`. The `cssValueType` property is a numeric constant indicating the type of value being represented: 0 for an inherited value, 1 for a primitive value, 2 for a list, or 3 for a custom value. The following code outputs the CSS property value and the value type:

```
let prop, value, i, len;
for (i = 0, len = myDiv.style.length; i < len; i++) {
  prop = myDiv.style[i]; // alternately, myDiv.style.item(i)
  value = myDiv.style.getPropertyCSSValue(prop);
  console.log('prop: ${value.cssText} (${value.cssValueType})');
}
```

The `removeProperty()` method is used to remove a specific CSS property from the element's styling. Removing a property using this method means that any default styling for that property (cascading from other style sheets) will be applied. For instance, to remove a `border` property that was set in the `style` attribute, you can use the following code:

```
myDiv.style.removeProperty("border");
```

This method is helpful when you're not sure what the default value for a given CSS property is. Simply removing the property allows the default value to be used.

Computed Styles

The `style` object offers information about the `style` attribute on any element that supports it but contains no information about the styles that have cascaded from style sheets and affect the element. DOM Level 2 Style augments `document.defaultView` to provide a method called `getComputedStyle()`. This method accepts two arguments: the element to get the computed style for and a pseudo-element string (such as `:after`). The second argument can be `null` if no pseudo-element information is necessary. The `getComputedStyle()` method returns a `CSSStyleDeclaration` object (the same type as the `style` property) containing all computed styles for the element. Consider the following HTML page:

```
<!DOCTYPE html>
<html>
<head>
  <title>Computed Styles Example</title>
  <style type="text/css">
    #myDiv {
      background-color: blue;
      width: 100px;
      height: 200px;
    }
  </style>
</head>
<body>
  <div id="myDiv" style="background-color: red; border: 1px solid black"></div>
</body>
</html>
```

In this example, the `<div>` element has styles applied to it both from an inline style sheet (the `<style>` element) and from the `style` attribute. The `style` object has values for `backgroundColor` and `border`, but nothing for `width` and `height`, which are applied through a style sheet rule. The following code retrieves the computed style for the element:

```
let myDiv = document.getElementById("myDiv");
let computedStyle = document.defaultView.getComputedStyle(myDiv, null);

console.log(computedStyle.backgroundColor); // "red"
console.log(computedStyle.width);         // "100px"
console.log(computedStyle.height);        // "200px"
console.log(computedStyle.border);         // "1px solid black" in some browsers
```

When retrieving the computed style of this element, the background color is reported as `"red"`, the width as `"100px"`, and the height as `"200px"`. Note that the background color is not `"blue"` because that style is overridden on the element itself. The `border` property may or may not return the exact border rule from the style sheet. (Opera returns it, but other browsers do not.) This inconsistency is due to the way that browsers interpret rollup properties, such as `border`, that actually set a number of other properties. When you set `border`, you're actually setting rules for the border width, color, and style on all four borders (`border-left-width`, `border-top-color`, `border-bottom-style`, and so on). So even though `computedStyle.border` may not return a value in all browsers, `computedStyle.borderLeftWidth` does.

NOTE *Although some browsers support this functionality, the manner in which values are represented can differ. For example, Firefox and Safari translate all colors into RGB form (such as `rgb(255,0,0)` for red), whereas Opera translates all colors into their hexadecimal representations (`#FF0000` for red). It's always best to test your functionality on a number of browsers when using `getComputedStyle()`.*

The important thing to remember about computed styles in all browsers is that they are read-only; you cannot change CSS properties on a computed style object. Also, the computed style contains styling information that is part of the browser's internal style sheet, so any CSS property that has a default value will be represented in the computed style. For instance, the `visibility` property always has a default value in all browsers, but this value differs per implementation. Some browsers set the `visibility` property to "visible" by default, whereas others have it as "inherit". You cannot depend on the default value of a CSS property to be the same across browsers. If you need elements to have a specific default value, you should manually specify it in a style sheet.

Working with Style Sheets

The `CSSStyleSheet` type represents a CSS style sheet as included using a `<link>` element or defined in a `<style>` element. Note that the elements themselves are represented by the `HTMLLinkElement` and `HTMLStyleElement` types, respectively. The `CSSStyleSheet` type is generic enough to represent a style sheet no matter how it is defined in HTML. Furthermore, the element-specific types allow for modification of HTML attributes, whereas a `CSSStyleSheet` object is, with the exception of one property, a read-only interface.

The `CSSStyleSheet` type inherits from `StyleSheet`, which can be used as a base to define non-CSS style sheets. The following properties are inherited from `StyleSheet`:

- `disabled`—A Boolean value indicating if the style sheet is disabled. This property is read/write, so setting its value to `true` will disable a style sheet.
- `href`—The URL of the style sheet if it is included using `<link>`; otherwise, this is `null`.
- `media`—A collection of media types supported by this style sheet. The collection has a `length` property and `item()` method, as with all DOM collections. Like other DOM collections, you can use bracket notation to access specific items in the collection. An empty list indicates that the style sheet should be used for all media.
- `ownerNode`—Pointer to the node that owns the style sheet, which is either a `<link>` or a `<style>` element in HTML (it can be a processing instruction in XML). This property is `null` if a style sheet is included in another style sheet using `@import`.
- `parentStyleSheet`—When a style sheet is included via `@import`, this is a pointer to the style sheet that imported it.
- `title`—The value of the `title` attribute on the `ownerNode`.
- `type`—A string indicating the type of style sheet. For CSS style sheets, this is "text/css".

With the exception of `disabled`, the rest of these properties are read-only. The `CSSStyleSheet` type supports all of these properties and the following properties and methods:

- `cssRules`—A collection of rules contained in the style sheet.
- `ownerRule`—If the style sheet was included using `@import`, this is a pointer to the rule representing the import; otherwise, this is `null`.
- `deleteRule(index)`—Deletes the rule at the given location in the `cssRules` collection.
- `insertRule(rule, index)`—Inserts the given string rule at the position specified in the `cssRules` collection.

The list of style sheets available on the document is represented by the `document.styleSheets` collection. The number of style sheets on the document can be retrieved using the `length` property, and each individual style sheet can be accessed using either the `item()` method or bracket notation. Here is an example:

```
let sheet = null;
for (let i = 0, len = document.styleSheets.length; i < len; i++) {
  sheet = document.styleSheets[i];
  console.log(sheet.href);
}
```

This code outputs the `href` property of each style sheet used in the document (`<style>` elements have no `href`).

The style sheets returned in `document.styleSheets` vary from browser to browser. All browsers include `<style>` elements and `<link>` elements with `rel` set to "stylesheet". Internet Explorer and Opera also include `<link>` elements where `rel` is set to "alternate stylesheet".

It's also possible to retrieve the `CSSStyleSheet` object directly from the `<link>` or `<style>` element. The DOM specifies a property called `sheet` that contains the `CSSStyleSheet` object.

CSS Rules

A `CSSRule` object represents each rule in a style sheet. The `CSSRule` type is actually a base type from which several other types inherit, but the most often used is `CSSStyleRule`, which represents styling information (other rules include `@import`, `@font-face`, `@page`, and `@charset`, although these rules rarely need to be accessed from script). The following properties are available on a `CSSStyleRule` object:

- `cssText`—Returns the text for the entire rule. This text may be different from the actual text in the style sheet because of the way that browsers handle style sheets internally; Safari always converts everything to all lowercase.
- `parentRule`—If this rule is imported, this is the import rule; otherwise, this is `null`.
- `parentStyleSheet`—The style sheet that this rule is a part of.
- `selectorText`—Returns the selector text for the rule. This text may be different from the actual text in the style sheet because of the way that browsers handle style sheets internally. This property is read-only in Firefox, Safari, Chrome, and Internet Explorer (where it throws an error). Opera allows `selectorText` to be changed.

- `style`—A `CSSStyleDeclaration` object that allows the setting and getting of specific style values for the rule.
- `type`—A constant indicating the type of rule. For style rules, this is always 1.

The three most frequently used properties are `cssText`, `selectorText`, and `style`. The `cssText` property is similar to the `style.cssText` property but not exactly the same. The former includes the selector text and the braces around the style information; the latter contains only the style information (similar to `style.cssText` on an element). Also, `cssText` is read-only, whereas `style.cssText` may be overwritten.

Most of the time, the `style` property is all that is required to manipulate style rules. This object can be used just like the one on each element to read or change the style information for a rule. Consider the following CSS rule:

```
div.box {
  background-color: blue;
  width: 100px;
  height: 200px;
}
```

Assuming that this rule is in the first style sheet on the page and is the only style in that style sheet, the following code can be used to retrieve all of its information:

```
let sheet = document.styleSheets[0];
let rules = sheet.cssRules || sheet.rules; // get rules list
let rule = rules[0]; // get first rule
console.log(rule.selectorText); // "div.box"
console.log(rule.style.cssText); // complete CSS code
console.log(rule.style.backgroundColor); // "blue"
console.log(rule.style.width); // "100px"
console.log(rule.style.height); // "200px"
```

Using this technique, it's possible to determine the style information related to a rule in the same way you can determine the inline style information for an element. As with elements, it's also possible to change the style information, as shown in the following example:

```
let sheet = document.styleSheets[0];
let rules = sheet.cssRules || sheet.rules; // get rules list
let rule = rules[0]; // get first rule
rule.style.backgroundColor = "red"
```

Note that changing a rule in this way affects all elements on the page for which the rule applies. If there are two `<div>` elements that have the `box` class, they will both be affected by this change.

Creating Rules

The DOM states that new rules are added to existing style sheets using the `insertRule()` method. This method expects two arguments: the text of the rule and the index at which to insert the rule. Here is an example:

```
sheet.insertRule("body { background-color: silver }", 0); // DOM method
```

This example inserts a rule that changes the document's background color. The rule is inserted as the first rule in the style sheet (position 0)—the order is important in determining how the rule cascades into the document.

Although adding rules in this way is possible, it quickly becomes burdensome when the number of rules to add is large. In that case, it's better to use the dynamic style loading technique discussed in the Document Object Model chapter.

Deleting Rules

The DOM method for deleting rules from a style sheet is `deleteRule()`, which accepts a single argument: the index of the rule to remove. To remove the first rule in a style sheet, you can use the following code:

```
sheet.deleteRule(0); // DOM method
```

As with adding rules, deleting rules is not a common practice in web development and should be used carefully because the cascading effect of CSS can be affected.

Element Dimensions

The following properties and methods are not part of the DOM Level 2 Style specification but nonetheless related to styles on HTML elements. The DOM stops short of describing ways to determine the actual dimensions of elements on a page. Internet Explorer first introduced several properties to expose dimension information to developers. These properties have now been incorporated into all of the major browsers.

Offset Dimensions

The first set of properties deals with *offset dimensions*, which incorporate all of the visual space that an element takes up on the screen. An element's visual space on the page is made up of its height and width, including all padding, scrollbars, and borders (but not including margins). The following four properties are used to retrieve offset dimensions:

- `offsetHeight`—The amount of vertical space, in pixels, taken up by the element, including its height, the height of a horizontal scrollbar (if visible), the top border height, and the bottom border height.
- `offsetLeft`—The number of pixels between the element's outside left border and the containing element's inside left border.
- `offsetTop`—The number of pixels between the element's outside top border and the containing element's inside top border.
- `offsetWidth`—The amount of horizontal space taken up by the element, including its width, the width of a vertical scrollbar (if visible), the left border width, and the right border width.

The `offsetLeft` and `offsetTop` properties are in relation to the containing element, which is stored in the `offsetParent` property. The `offsetParent` may not necessarily be the same as the

parentNode. For example, the `offsetParent` of a `<td>` element is the `<table>` element that it's an ancestor of, because the `<table>` is the first element in the hierarchy that provides dimensions. Figure 16-1 illustrates the various dimensions these properties represent.

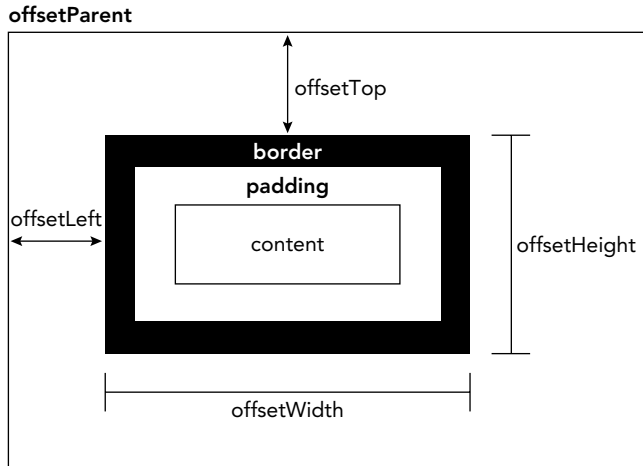

FIGURE 16-1:

The offset of an element on the page can roughly be determined by taking the `offsetLeft` and `offsetTop` properties and adding them to the same properties of the `offsetParent`, continuing up the hierarchy until you reach the root element. Here is an example:

```
function getElementLeft(element) {
  let actualLeft = element.offsetLeft;
  let current = element.offsetParent;

  while (current !== null) {
    actualLeft += current.offsetLeft;
    current = current.offsetParent;
  }

  return actualLeft;
}

function getElementTop(element) {
  let actualTop = element.offsetTop;
  let current = element.offsetParent;

  while (current !== null) {
    actualTop += current.offsetTop;
    current = current.offsetParent;
  }

  return actualTop;
}
```

These two functions climb through the DOM hierarchy using the `offsetParent` property, adding up the offset properties at each level. For simple page layouts using CSS-based layouts, these functions are very accurate. For page layouts using tables and iframes, the values returned are less accurate on a cross-browser basis because of the different ways that these elements are implemented. Generally, all elements that are contained solely within `<div>` elements have `<body>` as their `offsetParent`, so `getElementLeft()` and `getElementTop()` will return the same values as `offsetLeft` and `offsetTop`.

NOTE All of the offset dimension properties are read-only and are calculated each time they are accessed. Therefore, you should try to avoid making multiple calls to any of these properties; instead, store the values you need in local variables to avoid incurring a performance penalty.

Client Dimensions

The *client dimensions* of an element comprise the space occupied by the element's content and its padding. There are only two properties related to client dimensions: `clientWidth` and `clientHeight`. The `clientWidth` property is the width of the content area plus the width of both the left and the right padding. The `clientHeight` property is the height of the content area plus the height of both the top and the bottom padding. Figure 16-2 illustrates these properties.

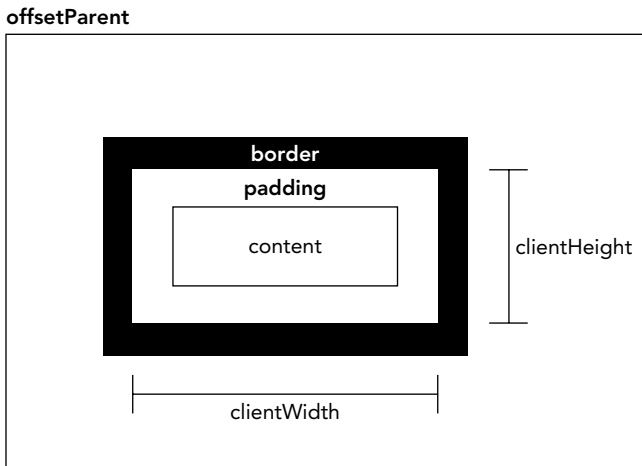

FIGURE 16-2:

The client dimensions are literally the amount of space inside of the element, so the space taken up by scrollbars is not counted. The most common use of these properties is to determine the browser viewport size. This is done by using the `clientWidth` and

`clientHeight` of `document.documentElement`. These properties represent the dimensions of the viewport (the `<html>` or `<body>` elements).

NOTE *As with offset dimensions, client dimensions are read-only and are calculated each time they are accessed.*

Scroll Dimensions

The last set of dimensions is *scroll dimensions*, which provide information about an element whose content is scrolling. Some elements, such as the `<html>` element, scroll automatically without needing any additional code, whereas other elements can be made to scroll by using the CSS `overflow` property. The four scroll dimension properties are as follows:

- `scrollHeight`—The total height of the content if there were no scrollbars present.
- `scrollLeft`—The number of pixels that are hidden to the left of the content area. This property can be set to change the scroll position of the element.
- `scrollTop`—The number of pixels that are hidden in the top of the content area. This property can be set to change the scroll position of the element.
- `scrollWidth`—The total width of the content if there were no scrollbars present.

Figure 16-3 illustrates these properties.

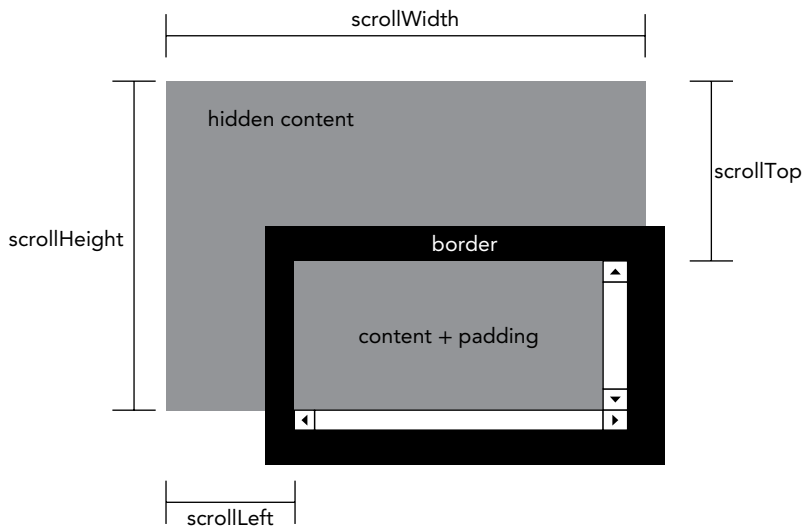

FIGURE 16-3:

The `scrollWidth` and `scrollHeight` properties are useful for determining the actual dimensions of the content in a given element. For example, the `<html>` element is considered the element that scrolls the viewport in a web browser. Therefore, the height of an entire page that has a vertical scrollbar is `document.documentElement.scrollHeight`.

The relationship between `scrollWidth` and `scrollHeight` to `clientWidth` and `clientHeight` is not clear when it comes to documents that do not scroll. Inspecting these properties on `document.documentElement` leads to inconsistent results across browsers, as described here:

- Firefox keeps the properties equal, but the size is related to the actual size of the document content, not the size of the viewport.
- Opera, Safari, and Chrome keep the properties different, with `scrollWidth` and `scrollHeight` equal to the size of the viewport and `clientWidth` and `clientHeight` equal to the document content.
- Internet Explorer (in standards mode) keeps the properties different, with `scrollWidth` and `scrollHeight` equal to the size of the document content, and `clientWidth` and `clientHeight` equal to the viewport size.

When trying to determine the total height of a document, including the minimum height based on the viewport, you must take the maximum value of `scrollWidth/clientWidth` and `scrollHeight/clientHeight` to guarantee accurate results across browsers. Here is an example:

```
let docHeight = Math.max(document.documentElement.scrollHeight,
                        document.documentElement.clientHeight);

let docWidth = Math.max(document.documentElement.scrollWidth,
                       document.documentElement.clientWidth);
```

The `scrollLeft` and `scrollTop` properties can be used either to determine the current scroll settings on an element or to set them. When an element hasn't been scrolled, both properties are equal to 0. If the element has been scrolled vertically, `scrollTop` is greater than 0, indicating the amount of content that is not visible at the top of the element. If the element has been scrolled horizontally, `scrollLeft` is greater than 0, indicating the number of pixels that are not visible on the left. Because each property can also be set, you can reset the element's scroll position by setting both `scrollLeft` and `scrollTop` to 0. The following function checks to see if the element is at the top, and if not, it scrolls it back to the top:

```
function scrollToTop(element) {
  if (element.scrollTop != 0) {
    element.scrollTop = 0;
  }
}
```

This function uses `scrollTop` both for retrieving the value and for setting it.

Determining Element Dimensions

Browsers offer a method called `getBoundingClientRect()` on each element, which returns a `DOMRect` object that has six properties: `left`, `top`, `right`, `bottom`, `height`, and `width`. These properties give the location of the element on the page relative to the viewport.

TRAVERSALS

The DOM Level 2 Traversal and Range module defines two types that aid in sequential traversal of a DOM structure. These types, `NodeIterator` and `TreeWalker`, perform depth-first traversals of a DOM structure given a certain starting point.

As stated previously, DOM traversals are a depth-first traversal of the DOM structure that allows movement in at least two directions (depending on the type being used). A traversal is rooted at a given node, and it cannot go any further up the DOM tree than that root. Consider the following HTML page:

```
<!DOCTYPE html>
<html>
  <head>
    <title>Example</title>
  </head>
  <body>
    <p><b>Hello</b> world!</p>
  </body>
</html>
```

This page evaluates to the DOM tree represented in Figure 16-4.

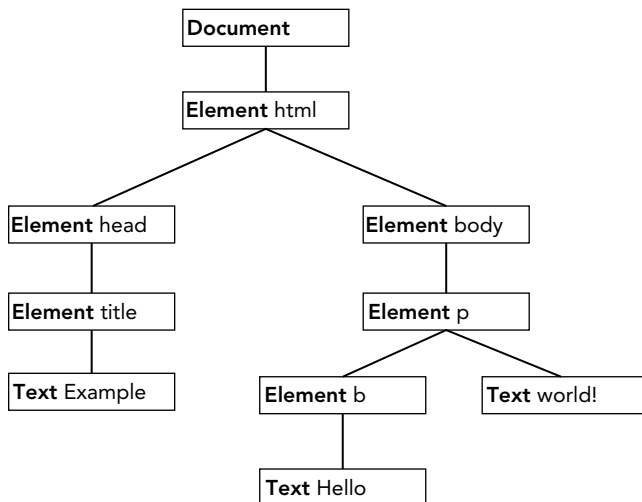

FIGURE 16-4:

Any node can be the root of the traversals. Suppose, for example, that the `<body>` element is the traversal root. The traversal can then visit the `<p>` element, the `` element, and the two text nodes that are descendants of `<body>`; however, the traversal can never reach the `<html>` element, the `<head>` element, or any other node that isn't in the `<body>` element's subtree. A traversal that has its root at `document`, on the other hand, can access all of the nodes in `document`. Figure 16-5 depicts a depth-first traversal of a DOM tree rooted at `document`.

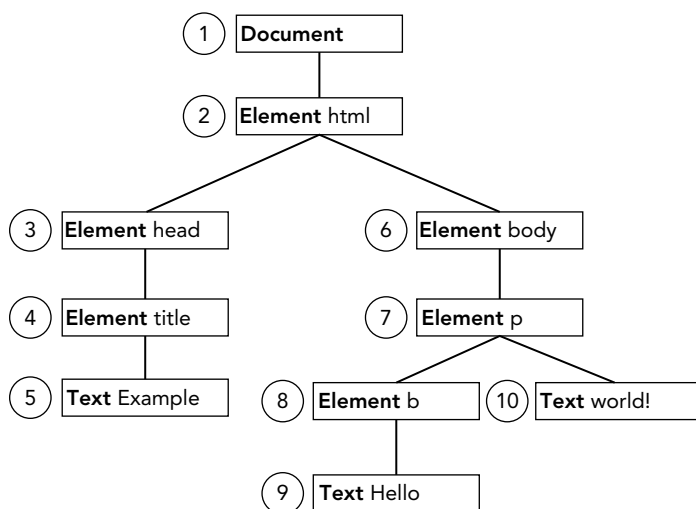

FIGURE 16-5:

Starting at `document` and moving sequentially, the first node visited is `document` and the last node visited is the text node containing " world!". From the very last text node at the end of the document, the traversal can be reversed to go back up the tree. In that case, the first node visited is the text node containing " world!" and the last one visited is the `document` node itself. Both `NodeIterator` and `TreeWalker` perform traversals in this manner.

NodeIterator

The `NodeIterator` type is the simpler of the two, and a new instance can be created using the `document.createNodeIterator()` method. This method accepts the following four arguments:

- `root`—The node in the tree that you want to start searching from.
- `whatToShow`—A numerical code indicating which nodes should be visited.
- `filter`—A `NodeFilter` object or a function indicating whether a particular node should be accepted or rejected.
- `entityReferenceExpansion`—A Boolean value indicating whether entity references should be expanded. This has no effect in HTML pages because entity references are never expanded.

The `whatToShow` argument is a bitmask that determines which nodes to visit by applying one or more filters. Possible values for this argument are included as constants on the `NodeFilter` type as follows:

- `NodeFilter.SHOW_ALL`—Show all node types.
- `NodeFilter.SHOW_ELEMENT`—Show element nodes.
- `NodeFilter.SHOW_ATTRIBUTE`—Show attribute nodes. This can't actually be used because of the DOM structure.
- `NodeFilter.SHOW_TEXT`—Show text nodes.
- `NodeFilter.SHOW_CDATA_SECTION`—Show CDATA section nodes. This is not used in HTML pages.
- `NodeFilter.SHOW_ENTITY_REFERENCE`—Show entity reference nodes. This is not used in HTML pages.
- `NodeFilter.SHOW_ENTITY`—Show entity nodes. This is not used in HTML pages.
- `NodeFilter.SHOW_PROCESSING_INSTRUCTION`—Show PI nodes. This is not used in HTML pages.
- `NodeFilter.SHOW_COMMENT`—Show comment nodes.
- `NodeFilter.SHOW_DOCUMENT`—Show document nodes.
- `NodeFilter.SHOW_DOCUMENT_TYPE`—Show document type nodes.
- `NodeFilter.SHOW_DOCUMENT_FRAGMENT`—Show document fragment nodes. This is not used in HTML pages.
- `NodeFilter.SHOW_NOTATION`—Show notation nodes. This is not used in HTML pages.

With the exception of `NodeFilter.SHOW_ALL`, you can combine multiple options using the bitwise OR operator, as shown in the following example:

```
let whatToShow = NodeFilter.SHOW_ELEMENT | NodeFilter.SHOW_TEXT;
```

The `filter` argument of `createNodeIterator()` can be used to specify a custom `NodeFilter` object or a function that acts as a node filter. A `NodeFilter` object has only one method, `acceptNode()`, which returns `NodeFilter.FILTER_ACCEPT` if the given node should be visited or `NodeFilter.FILTER_SKIP` if the given node should not be visited. Because `NodeFilter` is an abstract type, it's not possible to create an instance of it. Instead, just create an object with an `acceptNode()` method and pass the object into `createNodeIterator()`. The following code accepts only `<p>` elements:

```
let filter = {
  acceptNode(node) {
    return node.tagName.toLowerCase() == "p" ?
      NodeFilter.FILTER_ACCEPT :
      NodeFilter.FILTER_SKIP;
  }
};

let iterator = document.createNodeIterator(root, NodeFilter.SHOW_ELEMENT,
  filter, false);
```

The third argument can also be a function that takes the form of the `acceptNode()` method, as shown in this example:

```
let filter = function(node) {
  return node.tagName.toLowerCase() == "p" ?
    NodeFilter.FILTER_ACCEPT :
    NodeFilter.FILTER_SKIP;
};

let iterator = document.createNodeIterator(root, NodeFilter.SHOW_ELEMENT,
  filter, false);
```

Typically, this is the form that is used in JavaScript because it is simpler and works more like the rest of JavaScript. If no filter is required, the third argument should be set to `null`.

To create a simple `NodeIterator` that visits all node types, use the following code:

```
let iterator = document.createNodeIterator(document, NodeFilter.SHOW_ALL,
  null, false);
```

The two primary methods of `NodeIterator` are `nextNode()` and `previousNode()`. The `nextNode()` method moves one step forward in the depth-first traversal of the DOM subtree, and `previousNode()` moves one step backward in the traversal. When the `NodeIterator` is first created, an internal pointer points to the root, so the first call to `nextNode()` returns the root. When the traversal has reached the last node in the DOM subtree, `nextNode()` returns `null`. The `previousNode()` method works in a similar way. When the traversal has reached the last node in the DOM subtree, after `previousNode()` has returned the root of the traversal, it will return `null`.

Consider the following HTML fragment:

```
<div id="div1">
  <p><b>Hello</b> world!</p>
  <ul>
    <li>List item 1</li>
    <li>List item 2</li>
    <li>List item 3</li>
  </ul>
</div>
```

Suppose that you would like to traverse all elements inside of the `<div>` element. This can be accomplished using the following code:

```
let div = document.getElementById("div1");
let iterator = document.createNodeIterator(div, NodeFilter.SHOW_ELEMENT,
  null, false);

let node = iterator.nextNode();
while (node !== null) {
  console.log(node.tagName); // output the tag name
  node = iterator.nextNode();
}
```

The first call to `nextNode()` in this example returns the `<p>` element. Because `nextNode()` returns `null` when it has reached the end of the DOM subtree, a `while` loop checks to see when `null` has

been returned as it calls `nextNode()` each time through. When this code is executed, logs are displayed with the following tag names:

```
DIV
P
B
UL
LI
LI
LI
```

Perhaps this is too much information and you really only want to return the `` elements that occur in the traversal. This can be accomplished by using a filter, as shown in the following example:

```
let div = document.getElementById("div1");
let filter = function(node) {
  return node.tagName.toLowerCase() == "li" ?
    NodeFilter.FILTER_ACCEPT :
    NodeFilter.FILTER_SKIP;
};

let iterator = document.createNodeIterator(div, NodeFilter.SHOW_ELEMENT,
  filter, false);

let node = iterator.nextNode();
while (node !== null) {
  console.log(node.tagName); // output the tag name
  node = iterator.nextNode();
}
```

In this example, only `` elements will be returned from the iterator.

The `nextNode()` and `previousNode()` methods work with `NodeIterator`'s internal pointer in the DOM structure, so changes to the structure are represented appropriately in the traversal.

TreeWalker

`TreeWalker` is a more advanced version of `NodeIterator`. It has the same functionality, including `nextNode()` and `previousNode()`, and adds the following methods to traverse a DOM structure in different directions:

- `parentNode()`—Travels to the current node's parent.
- `firstChild()`—Travels to the first child of the current node.
- `lastChild()`—Travels to the last child of the current node.
- `nextSibling()`—Travels to the next sibling of the current node.
- `previousSibling()`—Travels to the previous sibling of the current node.

A `TreeWalker` object is created using the `document.createTreeWalker()` method, which accepts the same arguments as `document.createNodeIterator()`: the root to traverse from, which node

types to show, a filter, and a Boolean value indicating if entity references should be expanded. Because of these similarities, `TreeWalker` can always be used in place of `NodeIterator`, as in this example:

```
let div = document.getElementById("div1");
let filter = function(node) {
  return node.tagName.toLowerCase() == "li" ?
    NodeFilter.FILTER_ACCEPT :
    NodeFilter.FILTER_SKIP;
};

let walker = document.createTreeWalker(div, NodeFilter.SHOW_ELEMENT,
  filter, false);

let node = iterator.nextNode();
while (node !== null) {
  console.log(node.tagName); // output the tag name
  node = iterator.nextNode();
}
```

One difference is in the values that the filter can return. In addition to `NodeFilter.FILTER_ACCEPT` and `NodeFilter.FILTER_SKIP`, there is `NodeFilter.FILTER_REJECT`. When used with a `NodeIterator` object, `NodeFilter.FILTER_SKIP` and `NodeFilter.FILTER_REJECT` do the same thing: they skip over the node. When used with a `TreeWalker` object, `NodeFilter.FILTER_SKIP` skips over the node and goes on to the next node in the subtree, whereas `NodeFilter.FILTER_REJECT` skips over that node and that node's entire subtree. For instance, changing the filter in the previous example to return `NodeFilter.FILTER_REJECT` instead of `NodeFilter.FILTER_SKIP` will result in no nodes being visited. This is because the first element returned is `<div>`, which does not have a tag name of "li", so `NodeFilter.FILTER_REJECT` is returned, indicating that the entire subtree should be skipped. Because the `<div>` element is the traversal root, this means that the traversal stops.

Of course, the true power of `TreeWalker` is its ability to move around the DOM structure. Instead of specifying filter, it's possible to get at the `` elements by navigating through the DOM tree using `TreeWalker`, as shown here:

```
let div = document.getElementById("div1");
let walker = document.createTreeWalker(div, NodeFilter.SHOW_ELEMENT, null, false);

walker.firstChild(); // go to <p>
walker.nextSibling(); // go to <ul>

let node = walker.firstChild(); // go to first <li>
while (node !== null) {
  console.log(node.tagName);
  node = walker.nextSibling();
}
```

Because you know where the `` elements are located in the document structure, it's possible to navigate there, using `firstChild()` to get to the `<p>` element, `nextSibling()` to get to the `` element, and then `firstChild()` to get to the first `` element. Keep in mind that `TreeWalker` is returning only elements (because of the second argument passed in to `createTreeWalker()`). Then, `nextSibling()` can be used to visit each `` until there are no more, at which point the method returns `null`.

The `TreeWalker` type also has a property called `currentNode` that indicates the node that was last returned from the traversal via any of the traversal methods. This property can also be set to change where the traversal continues from when it resumes, as shown in this example:

```
let node = walker.nextNode();
console.log(node === walker.currentNode); // true
walker.currentNode = document.body;      // change where to start from
```

Compared to `NodeIterator`, the `TreeWalker` type allows greater flexibility when traversing the DOM.

RANGES

To allow an even greater measure of control over a page, the DOM Level 2 Traversal and Range module defines an interface called a range. A range can be used to select a section of a document regardless of node boundaries. (This selection occurs behind the scenes and cannot be seen by the user.) Ranges are helpful when regular DOM manipulation isn't specific enough to change a document.

Ranges in the DOM

DOM Level 2 defines a method on the `Document` type called `createRange()`, which belongs to the `document` object. A DOM range can be created using `createRange()`, as shown here:

```
let range = document.createRange();
```

Similar to nodes, the newly created range is tied directly to the document on which it was created and cannot be used on other documents. This range can then be used to select specific parts of the document behind the scenes. Once a range has been created and its position set, a number of different operations can be performed on the contents of the range, allowing more fine-grained manipulation of the underlying DOM tree.

Each range is represented by an instance of the `Range` type, which has a number of properties and methods. The following properties provide information about where the range is located in the document:

- `startContainer`—The node within which the range starts (the parent of the first node in the selection).
- `startOffset`—The offset within the `startContainer` where the range starts. If `startContainer` is a text node, comment node, or `CData` node, the `startOffset` is the number of characters skipped before the range starts; otherwise, the offset is the index of the first child node in the range.
- `endContainer`—The node within which the range ends (the parent of the last node in the selection).

- `endOffset`—The offset within the `endContainer` where the range ends (follows the same rules as `startOffset`).
- `commonAncestorContainer`—The deepest node in the document that has both `startContainer` and `endContainer` as descendants.

These properties are filled when the range is placed into a specific position in the document.

Simple Selection in DOM Ranges

The simplest way to select a part of the document using a range is to use either `selectNode()` or `selectNodeContents()`. These methods each accept one argument, a DOM node, and fill a range with information from that node. The `selectNode()` method selects the entire node, including its children, whereas `selectNodeContents()` selects only the node's children. For example, consider the following HTML:

```
<!DOCTYPE html>
<html>
  <body>
    <p id="p1"><b>Hello</b> world!</p>
  </body>
</html>
```

This code can be accessed using the following JavaScript:

```
let range1 = document.createRange(),
    range2 = document.createRange(),
    p1 = document.getElementById("p1");
range1.selectNode(p1);
range2.selectNodeContents(p1);
```

The two ranges in this example contain different sections of the document: `range1` contains the `<p>` element and all its children, whereas `range2` contains the `` element, the text node "Hello", and the text node "world!", as seen in Figure 16-6.

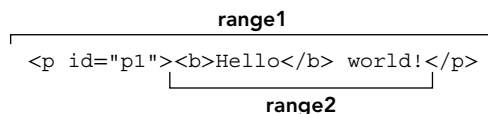

FIGURE 16-6:

When `selectNode()` is called, `startContainer`, `endContainer`, and `commonAncestorContainer` are all equal to the parent node of the node that was passed in; in this example, these would all be equal to `document.body`. The `startOffset` property is equal to the index of the given node within the parent's `childNodes` collection (which is 1 in this example—remember DOM-compliant browsers count white space as text nodes), whereas `endOffset` is equal to the `startOffset` plus one (because only one node is selected).

When `selectNodeContents()` is called, `startContainer`, `endContainer`, and `commonAncestorContainer` are equal to the node that was passed in, which is the `<p>` element in this example.

The `startOffset` property is always equal to 0, because the range begins with the first child of the given node, whereas `endOffset` is equal to the number of child nodes (`node.childNodes.length`), which is 2 in this example.

It's possible to get more fine-grained control over which nodes are included in the selection by using the following range methods:

- `setStartBefore(refNode)`—Sets the starting point of the range to begin before `refNode`, so `refNode` is the first node in the selection. The `startContainer` property is set to `refNode.parentNode`, and the `startOffset` property is set to the index of `refNode` within its parent's `childNodes` collection.
- `setStartAfter(refNode)`—Sets the starting point of the range to begin after `refNode`, so `refNode` is not part of the selection; rather, its next sibling is the first node in the selection. The `startContainer` property is set to `refNode.parentNode`, and the `startOffset` property is set to the index of `refNode` within its parent's `childNodes` collection plus one.
- `setEndBefore(refNode)`—Sets the ending point of the range to begin before `refNode`, so `refNode` is not part of the selection; its previous sibling is the last node in the selection. The `endContainer` property is set to `refNode.parentNode`, and the `endOffset` property is set to the index of `refNode` within its parent's `childNodes` collection.
- `setEndAfter(refNode)`—Sets the ending point of the range to begin before `refNode`, so `refNode` is the last node in the selection. The `endContainer` property is set to `refNode.parentNode`, and the `endOffset` property is set to the index of `refNode` within its parent's `childNodes` collection plus one.

When you use any of these methods, all properties are assigned for you. However, it is possible to assign these values directly in order to make complex range selections.

Complex Selection in DOM Ranges

Creating complex ranges requires the use of the `setStart()` and `setEnd()` methods. Both methods accept two arguments: a reference node and an offset. For `setStart()`, the reference node becomes the `startContainer`, and the offset becomes the `startOffset`. For `setEnd()`, the reference node becomes the `endContainer`, and the offset becomes the `endOffset`.

With these methods, it is possible to mimic `selectNode()` and `selectNodeContents()`. Here is an example:

```
let range1 = document.createRange(),
    range2 = document.createRange(),
    p1 = document.getElementById("p1"),
    p1Index = -1,
    i,
    len;
for (i = 0, len = p1.parentNode.childNodes.length; i < len; i++) {
  if (p1.parentNode.childNodes[i] === p1) {
    p1Index = i;
    break;
  }
}
```

```

range1.setStart(p1.parentNode, p1Index);
range1.setEnd(p1.parentNode, p1Index + 1);
range2.setStart(p1, 0);
range2.setEnd(p1, p1.childNodes.length);

```

Note that to select the node (using `range1`), you must first determine the index of the given node (`p1`) in its parent node's `childNodes` collection. To select the node contents (using `range2`), you do not need calculations; `setStart()` and `setEnd()` can be set with default values. Although mimicking `selectNode()` and `selectNodeContents()` is possible, the real power of `setStart()` and `setEnd()` is in the partial selection of nodes.

Suppose that you want to select only from the "llo" in "Hello" to the "o" in "world!" in the previous HTML code. This is quite easy to accomplish. The first step is to get references to all of the relevant nodes, as shown in the following example:

```

let p1 = document.getElementById("p1"),
    helloNode = p1.firstChild.firstChild,
    worldNode = p1.lastChild

```

The "Hello" text node is actually a grandchild of `<p>` because it's a child of ``, so you can use `p1.firstChild` to get `` and `p1.firstChild.firstChild` to get the text node. The "world!" text node is the second (and the last) child of `<p>`, so you can use `p1.lastChild` to retrieve it. Next, the range must be created and its boundaries defined, as shown in the following example:

```

let range = document.createRange();
range.setStart(helloNode, 2);
range.setEnd(worldNode, 3);

```

Because the selection should start after the "e" in "Hello", `helloNode` is passed into `setStart()` with an offset of 2 (the position after the "e" where "H" is in position 0). To set the end of the selection, pass `worldNode` into `setEnd()` with an offset of 3, indicating the first character that should not be selected, which is "r" in position 3 (there is actually a space in position 0). You'll see this illustrated in Figure 16-7.

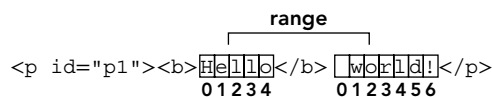

FIGURE 16-7:

Because both `helloNode` and `worldNode` are text nodes, they become the `startContainer` and `endContainer` for the range so that the `startOffset` and `endOffset` accurately look at the text contained within each node rather than look for child nodes (which is what happens when an element is passed in). The `commonAncestorContainer` is the `<p>` element, which is the first ancestor that contains both nodes.

Of course, just selecting sections of the document isn't very useful unless you can interact with the selection.

Interacting with DOM Range Content

When a range is created, internally it creates a document fragment node onto which all of the nodes in the selection are attached. The range contents must be well formed in order for this process to take place. In the previous example, the range does not represent a well-formed DOM structure because

the selection begins inside one text node and ends in another, which cannot be represented in the DOM. Ranges, however, recognize missing opening and closing tags and are, therefore, able to reconstruct a valid DOM structure to operate on.

In the previous example, the range calculates that a `` start tag is missing inside the selection, so the range dynamically adds it behind the scenes, along with a new `` end tag to enclose "He", thus altering the DOM to the following:

```
<p><b>He</b><b>llo</b> world!</p>
```

Additionally, the "world!" text node is split into two text nodes, one containing " wo" and the other containing "rld!". The resulting DOM tree is shown in Figure 16-8, along with the contents of the document fragment for the range.

With the range created, the contents of the range can be manipulated using a variety of methods. (Note that all nodes in the range's internal document fragment are simply pointers to nodes in the document.)

The first method is the simplest to understand and use: `deleteContents()`. This method simply deletes the contents of the range from the document. Here is an example:

```
let p1 = document.getElementById("p1"),
    helloNode = p1.firstChild.firstChild,
    worldNode = p1.lastChild,
    range = document.createRange();

range.setStart(helloNode, 2);
range.setEnd(worldNode, 3);

range.deleteContents();
```

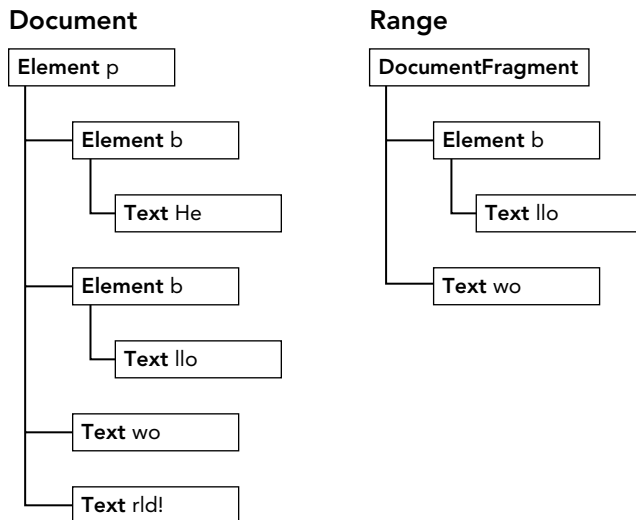

FIGURE 16-8:

Executing this code results in the following HTML being shown on the page:

```
<p><b>He</b>rld!</p>
```

Because the range selection process altered the underlying DOM structure to remain well formed, the resulting DOM structure is well formed even after removing the contents.

`extractContents()` is similar to `deleteContents()` in that it also removes the range selection from the document. The difference is that `extractContents()` returns the range's document fragment as the function value. This allows you to insert the contents of the range somewhere else. Here is an example:

```
let p1 = document.getElementById("p1"),
    helloNode = p1.firstChild.firstChild,
    worldNode = p1.lastChild,
    range = document.createRange();

range.setStart(helloNode, 2);
range.setEnd(worldNode, 3);

let fragment = range.extractContents();
p1.parentNode.appendChild(fragment);
```

In this example, the fragment is extracted and added to the end of the document's `<body>` element. (Remember, when a document fragment is passed into `appendChild()`, only the fragment's children are added, not the fragment itself.) The resulting HTML is as follows:

```
<p><b>He</b>rld!</p>
<b>llo</b> wo
```

Another option is to leave the range in place but create a clone of it that can be inserted elsewhere in the document by using `cloneContents()`, as shown in this example:

```
let p1 = document.getElementById("p1"),
    helloNode = p1.firstChild.firstChild,
    worldNode = p1.lastChild,
    range = document.createRange();

range.setStart(helloNode, 2);
range.setEnd(worldNode, 3);

let fragment = range.cloneContents();
p1.parentNode.appendChild(fragment);
```

This method is very similar to `extractContents()` because both return a document fragment. The main difference is that the document fragment returned by `cloneContents()` contains clones of the nodes contained in the range instead of the actual nodes. With this operation, the HTML in the page is as follows:

```
<p><b>Hello</b> world!</p>
<b>llo</b> wo
```

It's important to note that the splitting of nodes ensures that a well-formed document isn't produced until one of these methods is called. The original HTML remains intact right up until the point that the DOM is modified.

Inserting DOM Range Content

Ranges can be used to remove or clone content, as you saw in the previous section, and to manipulate the contents inside of the range. The `insertNode()` method enables you to insert a node at the beginning of the range selection. For example, suppose that you want to insert the following HTML prior to the HTML used in the previous example:

```
<span style="color: red">Inserted text</span>
```

The following code accomplishes this:

```
let p1 = document.getElementById("p1"),
    helloNode = p1.firstChild.firstChild,
    worldNode = p1.lastChild,
    range = document.createRange();

range.setStart(helloNode, 2);
range.setEnd(worldNode, 3);

let span = document.createElement("span");
span.style.color = "red";
span.appendChild(document.createTextNode("Inserted text"));
range.insertNode(span);
```

Running this JavaScript effectively creates the following HTML code:

```
<p id="p1"><b>He<span style="color: red">Inserted text</span>lllo</b> world</p>
```

Note that `` is inserted just before the "lllo" in "Hello", which is the first part of the range selection. Also note that the original HTML didn't add or remove `` elements because none of the methods introduced in the previous section were used. You can use this technique to insert helpful information, such as an image next to links that open in a new window.

Along with inserting content into the range, it is possible to insert content surrounding the range by using the `surroundContents()` method. This method accepts one argument, which is the node that surrounds the range contents. Behind the scenes, the following steps are taken:

1. The contents of the range are extracted.
2. The given node is inserted into the position in the original document where the range was.
3. The contents of the document fragment are added to the given node.

This sort of functionality is useful online to highlight certain words in a web page, as shown here:

```
let p1 = document.getElementById("p1"),
    helloNode = p1.firstChild.firstChild,
    worldNode = p1.lastChild,
    range = document.createRange();

range.selectNode(helloNode);
let span = document.createElement("span");
span.style.backgroundColor = "yellow";
range.surroundContents(span);
```

This code highlights the range selection with a yellow background. The resulting HTML is as follows:

```
<p><b><span style="background-color:yellow">Hello</span></b> world!</p>
```

In order to insert the ``, the range has to contain a whole DOM selection. (It can't have only partially selected DOM nodes.)

Collapsing a DOM Range

When a range isn't selecting any part of a document, it is said to be *collapsed*. Collapsing a range resembles the behavior of a text box. When you have text in a text box, you can highlight an entire word using the mouse. However, if you left-click the mouse again, the selection is removed and the cursor is located between two letters. When you collapse a range, its location is set between parts of a document, either at the beginning of the range selection or at the end. Figure 16-9 illustrates what happens when a range is collapsed.

You can collapse a range by using the `collapse()` method, which accepts a single argument: a Boolean value indicating which end of the range to collapse to. If the argument is `true`, then the range is collapsed to its starting point; if it is `false`, the range is collapsed to its ending point. To determine if a range is already collapsed, you can use the `collapsed` property as follows:

```
range.collapse(true); // collapse to the starting point
console.log(range.collapsed); // outputs "true"
```

Testing whether a range is collapsed is helpful if you aren't sure if two nodes in the range are next to each other. For example, consider this HTML code:

```
<p id="p1">Paragraph 1</p><p
id="p2">Paragraph 2</p>
```

If you don't know the exact makeup of this code (for example, if it is automatically generated), you might try creating a range like this:

```
let p1 = document.getElementById("p1"),
    p2 = document.getElementById("p2"),
    range = document.createRange();
range.setStartAfter(p1);
range.setStartBefore(p2);
console.log(range.collapsed); // true
```

In this case, the created range is collapsed because there is nothing between the end of `p1` and the beginning of `p2`.

Comparing DOM Ranges

If you have more than one range, you can use the `compareBoundaryPoints()` method to determine if the ranges have any boundaries (start or end) in common. The method accepts two arguments: the range to compare to and how to compare. It is one of the following constant values:

- `Range.START_TO_START` (0)—Compares the starting point of the first range to the starting point of the second.

```
<p id="p1"><b>Hello</b> world!</p>
```

Original Range

```
<p id="p1"><b>Hello</b> world!</p>
```

Collapsed to beginning

```
<p id="p1"><b>Hello</b> world!</p>
```

Collapsed to end

FIGURE 16-9:

- `Range.START_TO_END` (1)—Compares the starting point of the first range to the end point of the second.
- `Range.END_TO_END` (2)—Compares the end point of the first range to the end point of the second.
- `Range.END_TO_START` (3)—Compares the end point of the first range to the starting point of the second.

The `compareBoundaryPoints()` method returns `-1` if the point from the first range comes before the point from the second range, `0` if the points are equal, or `1` if the point from the first range comes after the point from the second range. Consider the following example:

```
let range1 = document.createRange();
let range2 = document.createRange();
let p1 = document.getElementById("p1");

range1.selectNodeContents(p1);
range2.selectNodeContents(p1);
range2.setEndBefore(p1.lastChild);

console.log(range1.compareBoundaryPoints(Range.START_TO_START, range2)); // 0
console.log(range1.compareBoundaryPoints(Range.END_TO_END, range2)); // 1
```

In this code, the starting points of the two ranges are exactly the same because both use the default value from `selectNodeContents()`; therefore, the method returns `0`. For `range2`, however, the end point is changed using `setEndBefore()`, making the end point of `range1` come after the end point of `range2` (see Figure 16-10), so the method returns `1`.

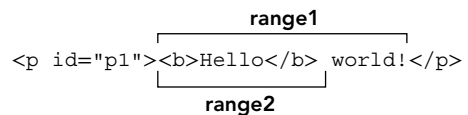

FIGURE 16-10:

Cloning DOM Ranges

Ranges can be cloned by calling the `cloneRange()` method. This method creates an exact duplicate of the range on which it is called:

```
let newRange = range.cloneRange();
```

The new range contains all of the same properties as the original, and its end points can be modified without affecting the original in any way.

Cleanup

When you are done using a range, it is best to call the `detach()` method, which detaches the range from the document on which it was created. After calling `detach()`, the range can be safely dereferenced, so the memory can be reclaimed through garbage collection. Here is an example:

```
range.detach(); // detach from document
range = null; // dereferenced
```

Following these two steps is the most appropriate way to finish using a range. Once it is detached, a range can no longer be used.

SUMMARY

The DOM Level 2 specifications define several modules that augment the functionality of DOM Level 1. DOM Level 2 Core introduces several new methods related to XML namespaces on various DOM types. These changes are relevant only when used in XML or XHTML documents; they have no use in HTML documents. Methods not related to XML namespaces include the ability to programmatically create new instances of `Document` and to enable the creation of `DocumentType` objects.

The DOM Level 2 Style module specifies how to interact with stylistic information about elements as follows:

- Every element has a `style` object associated with it that can be used to determine and change inline styles.
- To determine the computed style of an element, including all CSS rules that apply to it, you can use a method called `getComputedStyle()`.
- It's also possible to access style sheets via the `document.styleSheets` collection.

The DOM Level 2 Traversals and Range module specifies different ways to interact with a DOM structure as follows:

- Traversals are handled using either `NodeIterator` or `TreeWalker` to perform depth-first traversals of a DOM tree.
- The `NodeIterator` interface is simple, allowing only forward and backward movement in one-step increments. The `TreeWalker` interface supports the same behavior and moves across the DOM structure in all other directions, including parents, siblings, and children.
- Ranges are a way to select specific portions of a DOM structure to augment it in some fashion.
- Selections of ranges can be used to remove portions of a document while retaining a well-formed document structure or for cloning portions of a document.

17

Events

WHAT'S IN THIS CHAPTER?

- Understanding event flow
- Working with event handlers
- Examining the different types of events

JavaScript's interaction with HTML is handled through *events*, which indicate when particular moments of interest occur in the document or browser window. Events can be subscribed to using *listeners* (also called handlers) that execute only when an event occurs. This model, called the “observer pattern” in traditional software engineering, allows a loose coupling between the behavior of a page (defined in JavaScript) and the appearance of the page (defined in HTML and CSS).

Events first appeared in Internet Explorer 3 and Netscape Navigator 2 as a way to offload some form processing from the server onto the browser. By the time Internet Explorer 4 and Netscape 4 were released, each browser delivered similar but different APIs that continued for several generations. DOM Level 2 was the first attempt to standardize the DOM events API in a logical way. All modern browsers have implemented the core parts of DOM Level 2 Events. Internet Explorer 8 was the last major browser to use a purely proprietary event system.

The browser event system is a complex one. Even though all major browsers have implemented DOM Level 2 Events, the specification doesn't cover all event types. The BOM also supports events, and the relationship between these and the DOM events is often confusing because of a longtime lack of documentation (something that HTML5 has tried to clarify). Further complicating matters is the augmentation of the DOM events API by DOM Level 3. Working with events can be relatively simple or very complex, depending on your requirements. Still, there are some core concepts that are important to understand.

EVENT FLOW

When development for the fourth generation of web browsers began (Internet Explorer 4 and Netscape Communicator 4), the browser development teams were met with an interesting question: What part of a page owns a specific event? To understand the issue, consider a series of concentric circles on a piece of paper. When you place your finger at the center, it is inside of not just one circle but all of the circles on the page. Both development teams looked at browser events in the same way. When you click on a button, they concluded, you're clicking not just on the button but also on its container and on the page as a whole.

Event flow describes the order in which events are received on the page, and interestingly, the Internet Explorer and Netscape development teams came up with an almost exactly opposite concept of event flow. Internet Explorer would support an event bubbling flow, whereas Netscape Communicator would support an event capturing flow.

Event Bubbling

The Internet Explorer event flow is called *event bubbling* because an event is said to start at the most specific element (the deepest possible point in the document tree) and then flow upward toward the least specific node (the document). Consider the following HTML page:

```
<!DOCTYPE html>
<html>
<head>
  <title>Event Bubbling Example</title>
</head>
<body>
  <div id="myDiv">Click Me</div>
</body>
</html>
```

When you click the `<div>` element in the page, the `click` event occurs in the following order:

1. `<div>`
2. `<body>`
3. `<html>`
4. `document`

The `click` event is first fired on the `<div>`, which is the element that was clicked. Then the `click` event goes up the DOM tree, firing on each node along its way until it reaches the `document` object. Figure 17-1 illustrates this effect.

All modern browsers support event bubbling, although there are some variations on how it is implemented. Internet Explorer 5.5 and earlier skip bubbling to the `<html>` element (going from `<body>` directly to `document`). Modern browsers continue event bubbling up to the `window` object.

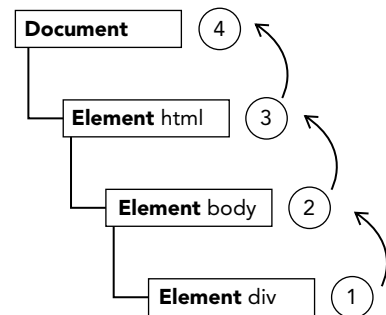

FIGURE 17-1:

Event Capturing

The Netscape Communicator team came up with an alternate event flow called *event capturing*. The theory of event capturing is that the least specific node should receive the event first and the most specific node should receive the event last. Event capturing was really designed to intercept the event before it reached the intended target. If the previous example is used with event capturing, clicking the `<div>` element fires the `click` event in the following order:

1. `document`
2. `<html>`
3. `<body>`
4. `<div>`

With event capturing, the `click` event is first received by the `document` and then continues down the DOM tree to the actual target of the event, the `<div>` element. This flow is illustrated in Figure 17-2.

Although this was Netscape Communicator's only event flow model, event capturing is supported in all modern browsers. All of them actually begin event capturing at the `window`-level event despite the fact that the DOM Level 2 Events specification indicates that the events should begin at `document`.

Event capturing is generally not used because of a lack of support in older browsers. The general advice is to use event bubbling freely while retaining event capturing for special circumstances.

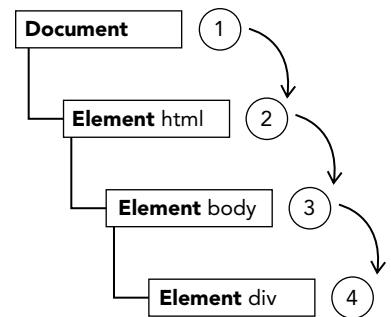

FIGURE 17-2:

DOM Event Flow

The event flow specified by DOM Level 2 Events has three phases: the event capturing phase, at the target, and the event bubbling phase. Event capturing occurs first, providing the opportunity to intercept events if necessary. Next, the actual target receives the event. The final phase is bubbling, which allows a final response to the event. Considering the simple HTML example used previously, clicking the `<div>` fires the event in the order indicated in Figure 17-3.

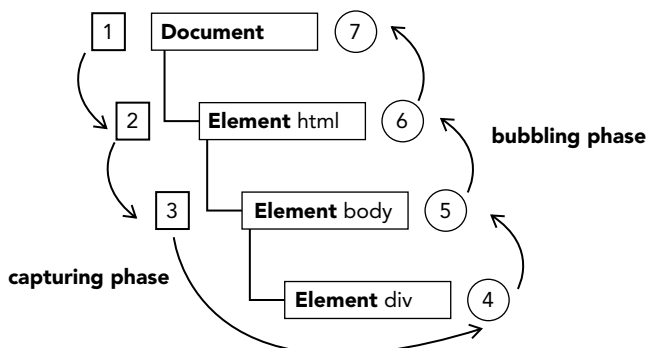

FIGURE 17-3:

In the DOM event flow, the actual target (the `<div>` element) does not receive the event during the capturing phase. This means that the capturing phase moves from `document` to `<html>` to `<body>` and stops. The next phase is “at target,” which fires on the `<div>` and is considered to be part of the bubbling phase in terms of event handling (discussed later). Then, the bubbling phase occurs and the event travels back up to the document.

Most of the browsers that support DOM event flow have implemented a quirk. Even though the DOM Level 2 Events specification indicates that the capturing phase doesn’t hit the event target, modern browsers all fire an event during the capturing phase on the event target. The end result is that there are two opportunities to work with the event on the target.

NOTE *All modern browsers support the DOM event flow; only Internet Explorer 8 and earlier do not.*

EVENT HANDLERS

Events are certain actions performed either by the user or by the browser itself. These events have names like `click`, `load`, and `mouseover`. A function that is called in response to an event is called an *event handler* (or an *event listener*). Event handlers have names beginning with “on”, so an event handler for the `click` event is called `onclick` and an event handler for the `load` event is called `onload`. Assigning event handlers can be accomplished in a number of different ways.

HTML Event Handlers

Each event supported by a particular element can be assigned using an HTML attribute with the name of the event handler. The value of the attribute should be some JavaScript code to execute. For example, to execute some JavaScript when a button is clicked, you can use the following:

```
<input type="button" value="Click Me" onclick="console.log('Clicked')"/>
```

When this button is clicked, a message is logged. This interaction is defined by specifying the `onclick` attribute and assigning some JavaScript code as the value. Note that because the JavaScript code is an attribute value, you cannot use HTML syntax characters such as the ampersand, double quotes, less-than, or greater-than without escaping them. In this case, single quotes were used instead of double quotes to avoid the need to use HTML entities. To use double quotes, you will change the code to the following:

```
<input type="button" value="Click Me"
  onclick="console.log(&quot;Clicked&quot;)" />
```

An event handler defined in HTML may contain the precise action to take or it can call a script defined elsewhere on the page, as in this example:

```
<script>
  function showMessage() {
    console.log("Hello world!");
  }
</script>
<input type="button" value="Click Me" onclick="showMessage()" />
```

In this code, the button calls `showMessage()` when it is clicked. The `showMessage()` function is defined in a separate `<script>` element and could also be included in an external file. Code executing as an event handler has access to everything in the global scope.

Event handlers assigned in this way have some unique aspects. First, a function is created that wraps the attribute value. That function has a special local variable called `event`, which is the event object (discussed later in this chapter):

```
<!-- outputs "click" -->
<input type="button" value="Click Me" onclick="console.log(event.type)">
```

This gives you access to the event object without needing to define it yourself and without needing to pull it from the enclosing function's argument list.

The `this` value inside of the function is equivalent to the event's target element, as shown in this example:

```
<!-- outputs "Click Me" -->
<input type="button" value="Click Me" onclick="console.log(this.value)">
```

Another interesting aspect of this dynamically created function is how it augments the scope chain. Within the function, members of both `document` and the element itself can be accessed as if they were local variables. The function accomplishes this via scope chain augmentation using `with`:

```
function() {
  with(document) {
    with(this) {
      // attribute value
    }
  }
}
```

This means that an event handler can access its own properties easily. The following is functionally the same as the previous example:

```
<!-- outputs "Click Me" -->
<input type="button" value="Click Me" onclick="console.log(value)">
```

If the element is a form input element, then the scope chain also contains an entry for the parent form element, making the function the equivalent to the following:

```
function() {
  with(document) {
    with(this.form) {
      with(this) {
        // attribute value
      }
    }
  }
}
```

Basically, this augmentation allows the event handler code to access other members of the same form without referencing the form element itself. This pattern of member access is demonstrated in the following example:

```
<form method="post">
  <input type="text" name="username" value="">
```

```

    <input type="button" value="Echo Username"
          onclick="console.log(username.value) ">
  </form>

```

Clicking the button in this example results in the text from the text box being displayed. Note that it just references `username` directly.

There are a few downsides to assigning event handlers in HTML. The first is a timing issue: It's possible that the HTML element appears on the page and is interacted with by the user before the event handler code is ready. In the previous example, imagine a scenario where the `showMessage()` function isn't defined until later on the page, after the code for the button. If the user were to click the button before `showMessage()` was defined, an error would occur. For this reason, most HTML event handlers are enclosed in `try-catch` blocks so that they quietly fail, as in the following example:

```

<input type="button" value="Click Me" onclick="try{showMessage();}catch(ex) {}">

```

If this button is clicked before the `showMessage()` function is defined, no JavaScript error occurs because the error is caught before the browser can handle it.

Another downside is that the scope chain augmentation in the event handler function can lead to different results in different browsers. The rules being followed for identifier resolution are slightly different amongst JavaScript engines, and so the result of accessing unqualified object members may cause errors.

The last downside to assigning event handlers using HTML is that it tightly couples the HTML to the JavaScript. If the event handler needs to be changed, you may need to change code in two places: in the HTML and in the JavaScript. This is the primary reason that many developers avoid HTML event handlers in favor of using JavaScript to assign event handlers.

DOM Level 0 Event Handlers

The traditional way of assigning event handlers in JavaScript is to assign a function to an event handler property. This was the event handler assignment method introduced in the fourth generation of web browsers, and it still remains in all modern browsers because of its simplicity and cross-browser support. To assign an event handler using JavaScript, you must first retrieve a reference to the object to act on.

Each element (as well as `window` and `document`) has event handler properties that are typically all lowercase, such as `onclick`. An event handler is assigned by setting the property equal to a function, as in this example:

```

let btn = document.getElementById("myBtn");
btn.onclick = function() {
  console.log("Clicked");
};

```

Here, a button is retrieved from the document and an `onclick` event handler is assigned. Note that the event handler isn't assigned until this code is run, so if the code appears after the code for the button in the page, there may be an amount of time during which the button will do nothing when clicked.

When assigning event handlers using the DOM Level 0 method, the event handler is considered to be a method of the element. The event handler, therefore, is run within the scope of element, meaning that `this` is equivalent to the element. The value of `this` is demonstrated in the following example:

```
let btn = document.getElementById("myBtn");
btn.onclick = function() {
  console.log(this.id); // "myBtn"
};
```

This code displays the element's ID when the button is clicked. The ID is retrieved using `this.id`. It's possible to use `this` to access any of the element's properties or methods from within the event handlers. Event handlers added in this way are intended for the bubbling phase of the event flow.

You can remove an event handler assigned via the DOM Level 0 approach by setting the value of the event handler property to `null`, as in the following example:

```
btn.onclick = null; // remove event handler
```

Once the event handler is set to `null`, the button no longer has any action to take when it is clicked.

NOTE *If you've assigned an event handler using HTML, the value on the `onclick` property is a function containing the code specified in the HTML attribute. These event handlers can also be removed by setting the property to `null`.*

DOM Level 2 Event Handlers

DOM Level 2 Events define two methods to deal with the assignment and removal of event handlers: `addEventListener()` and `removeEventListener()`. These methods exist on all DOM nodes and accept three arguments: the event name to handle, the event handler function, and a Boolean value indicating whether to call the event handler during the capture phase (`true`) or during the bubble phase (`false`).

To add an event handler for the `click` event on a button, you can use the following code:

```
let btn = document.getElementById("myBtn");
btn.addEventListener("click", () => {
  console.log(this.id);
}, false);
```

This code adds an `onclick` event handler to a button that will be fired in the bubbling phase (since the last argument is `false`). As with the DOM Level 0 approach, the event handler runs in the scope of the element on which it is attached. The major advantage to using the DOM Level 2 method for adding event handlers is that multiple event handlers can be added. Consider the following example:

```
let btn = document.getElementById("myBtn");
btn.addEventListener("click", () => {
  console.log(this.id);
}, false);
btn.addEventListener("click", () => {
  console.log("Hello world!");
}, false);
```

Here, two event handlers are added to the button. The event handlers fire in the order in which they were added, so the first log displays the element's ID and the second displays the message "Hello world!"

Event handlers added via `addEventListener()` can be removed only by using `removeEventListener()` and passing in the same arguments as were used when the handler was added. This means that anonymous functions added using `addEventListener()` cannot be removed, as shown in this example:

```
let btn = document.getElementById("myBtn");
btn.addEventListener("click", () => {
  console.log(this.id);
}, false);

// other code here

btn.removeEventListener("click", function() { // won't work!
  console.log(this.id);
}, false);
```

In this example, an anonymous function is added as an event handler using `addEventListener()`. The call to `removeEventListener()` looks like it's using the same arguments, but in reality, the second argument is a completely different function than the one used in `addEventListener()`. The event handler function passed into `removeEventListener()` must be the same one that was used in `addEventListener()`, as in this example:

```
let btn = document.getElementById("myBtn");
let handler = function() {
  console.log(this.id);
};
btn.addEventListener("click", handler, false);

// other code here

btn.removeEventListener("click", handler, false); // works!
```

This rewritten example works as expected because the same function is used for both `addEventListener()` and `removeEventListener()`.

In most cases, event handlers are added to the bubbling phase of the event flow because this offers the broadest possible cross-browser support. Attaching an event handler in the capture phase is best done if you need to intercept events before they reach their intended target. If this is not necessary, it's advisable to avoid event capturing.

Internet Explorer Event Handlers

Internet Explorer implements methods similar to the DOM called `attachEvent()` and `detachEvent()`. These methods accept the same two arguments: the event handler name and the event handler function. Because Internet Explorer 8 and earlier support only event bubbling, event handlers added using `attachEvent()` are attached on the bubbling phase.

To add an event handler for the `click` event on a button using `attachEvent()`, you can use the following code:

```
var btn = document.getElementById("myBtn");
btn.attachEvent("onclick", function() {
    console.log("Clicked");
});
```

Note that the first argument of `attachEvent()` is `"onclick"` as opposed to `"click"` in the DOM's `addEventListener()` method.

A major difference between using `attachEvent()` and using the DOM Level 0 approach in Internet Explorer is the scope of the event handler. When using DOM Level 0, the event handler runs with a `this` value equal to the element on which it is attached; when using `attachEvent()`, the event handler runs in the global context, so `this` is equivalent to `window`. Consider this example which uses `attachEvent()`:

```
var btn = document.getElementById("myBtn");
btn.attachEvent("onclick", function() {
    console.log(this === window); // true
});
```

This difference is important to understand when writing cross-browser code.

The `attachEvent()` method, similar to `addEventListener()`, can be used to add multiple event handlers to a single element. Consider the following example, which uses multiple `attachEvent()` calls:

```
var btn = document.getElementById("myBtn");
btn.attachEvent("onclick", function() {
    console.log("Clicked");
});
btn.attachEvent("onclick", function() {
    console.log("Hello world!");
});
```

Here, `attachEvent()` is called twice, adding two different event handlers to the same button. Unlike the DOM method, though, the event handlers fire in reverse of the order they were added. When the button in this example is clicked, the first log says "Hello world!" and the second says "Clicked".

Events added using `attachEvent()` are removed using `detachEvent()` as long as the same arguments are provided. As with the DOM methods, this means that anonymous functions cannot be removed once they have been added. Event handlers can always be removed as long as a reference to the same function can be passed into `detachEvent()`. Consider this example, which attaches and detaches an event:

```
var btn = document.getElementById("myBtn");
var handler = function() {
    console.log("Clicked");
};
btn.attachEvent("onclick", handler);

// other code here

btn.detachEvent("onclick", handler);
```

This example adds an event handler stored in the variable `handler`. That same function is later removed using `detachEvent()`.

Cross-Browser Event Handlers

To accommodate event handling in a cross-browser way, many developers end up either using a JavaScript library that abstracts away the browser differences or writing custom code to use the most appropriate event-handling approach. Writing your own code is fairly straightforward, because it relies on capability detection. To make sure that the event-handling code works in the most compatible way possible, you will need it to work only on the bubbling phase.

The first method to create is called `addHandler()`, and its job is to use the DOM Level 0 approach, the DOM Level 2 approach, or the Internet Explorer approach to adding events, depending on which is available. This method is attached to an object called `EventUtil` that is used throughout this chapter to aid in handling cross-browser differences. The `addHandler()` method accepts three arguments: the element to act on, the name of the event, and the event handler function.

The counterpart to `addHandler()` is `removeHandler()`, which accepts the same three arguments. This method's job is to remove a previously added event handler using whichever means is available, defaulting to DOM Level 0 if no other method is available.

The full code for `EventUtil` is as follows:

```
var EventUtil = {
  addHandler: function(element, type, handler) {
    if (element.addEventListener) {
      element.addEventListener(type, handler, false);
    } else if (element.attachEvent) {
      element.attachEvent("on" + type, handler);
    } else {
      element["on" + type] = handler;
    }
  },

  removeHandler: function(element, type, handler) {
    if (element.removeEventListener) {
      element.removeEventListener(type, handler, false);
    } else if (element.detachEvent) {
      element.detachEvent("on" + type, handler);
    } else {
      element["on" + type] = null;
    }
  }
};
```

Both methods first check for the existence of the DOM Level 2 method on the element that was passed in. If the DOM Level 2 method exists, it is used, passing in the event type and the event handler function, along with a third argument of `false` (to indicate the bubbling phase). If the Internet Explorer method is available, it is used as a second option. Note that the event type must be prefixed with "on" in order for it to work in Internet Explorer 8 and earlier. The last resort is to use the DOM Level 0 method (code should never reach here in modern browsers). Note the use of bracket notation to assign the property name to either the event handler or `null`.

This utility object can be used in the following way:

```
let btn = document.getElementById("myBtn");
let handler = function() {
  console.log("Clicked");
};
EventUtil.addHandler(btn, "click", handler);

// other code here

EventUtil.removeHandler(btn, "click", handler);
```

The `addHandler()` and `removeHandler()` methods don't equalize all functionality across all browsers, such as the Internet Explorer scope issue, but they do allow the seamless addition and removal of event handlers. Keep in mind, also, that DOM Level 0 support is limited to just one event handler per event. Fortunately, DOM Level 0 browsers are no longer in popular use, so this shouldn't affect you.

THE EVENT OBJECT

When an event related to the DOM is fired, all of the relevant information is gathered and stored on an object called `event`. This object contains basic information such as the element that caused the event, the type of event that occurred, and any other data that may be relevant to the particular event. For example, an event caused by a mouse action generates information about the mouse's position, whereas an event caused by a keyboard action generates information about the keys that were pressed. All browsers support the `event` object, though not in the same way.

The DOM Event Object

In DOM-compliant browsers, the `event` object is passed in as the sole argument to an event handler. Regardless of the method used to assign the event handler, DOM Level 0 or DOM Level 2, the `event` object is passed in. Here is an example which references the event object inside the handler both ways:

```
let btn = document.getElementById("myBtn");
btn.onclick = function(event) {
  console.log(event.type); // "click"
};

btn.addEventListener("click", (event) => {
  console.log(event.type); // "click"
}, false);
```

Both event handlers in this example log a message indicating the type of event being fired by using the `event.type` property. This property always contains the type of event that was fired, such as "click" (it is the same value that you pass into `addEventListener()` and `removeEventListener()`).

When an event handler is assigned using HTML attributes, the `event` object is available as a variable called `event`. This example demonstrates how to use this variable:

```
<input type="button" value="Click Me" onclick="console.log(event.type)">
```

Providing the `event` object in this way allows HTML attribute event handlers to perform the same as JavaScript functions.

The event object contains properties and methods related to the specific event that caused its creation. The available properties and methods differ based on the type of event that was fired, but all events have the members listed in the following table.

PROPERTY/METHOD	TYPE	READ/WRITE	DESCRIPTION
bubbles	Boolean	Read only	Indicates if the event bubbles.
cancelable	Boolean	Read only	Indicates if the default behavior of the event can be canceled.
currentTarget	Element	Read only	The element whose event handler is currently handling the event.
defaultPrevented	Boolean	Read only	When <code>true</code> , indicates that <code>preventDefault()</code> has been called (added in DOM Level 3 Events).
detail	Integer	Read only	Extra information related to the event.
eventPhase	Integer	Read only	The phase during which the event handler is being called: 1 for the capturing phase, 2 for "at target," and 3 for bubbling.
preventDefault()	Function	Read only	Cancels the default behavior for the event. If <code>cancelable</code> is <code>true</code> , this method can be used.
stopImmediatePropagation()	Function	Read only	Cancels any further event capturing or event bubbling and prevents any other event handlers from being called. (Added in DOM Level 3 Events.)
stopPropagation()	Function	Read only	Cancels any further event capturing or event bubbling. If <code>bubbles</code> is <code>true</code> , this method can be used.
target	Element	Read only	The target of the event.
trusted	Boolean	Read only	When <code>true</code> , indicates if the event was generated by the browser. When <code>false</code> , indicates the event was created using JavaScript by the developer. (Added in DOM Level 3 Events.)
type	String	Read only	The type of event that was fired.
view	AbstractView	Read only	The abstract view associated with the event. This is equal to the <code>window</code> object in which the event occurred.

Inside an event handler, the `this` object is always equal to the value of `currentTarget`, whereas `target` contains only the actual target of the event. If the event handler is assigned directly onto the intended target, then `this`, `currentTarget`, and `target` all have the same value. Here is an example demonstrating where the two properties are equivalent to `this`:

```
let btn = document.getElementById("myBtn");
btn.onclick = function(event) {
  console.log(event.currentTarget === this); // true
  console.log(event.target === this);      // true
};
```

This code examines the values of `currentTarget` and `target` relative to `this`. Because the target of the `click` event is the button, all three are equal. If the event handler existed on a parent node of the button, such as `document.body`, the values would be different. Consider the following example, where a click handler is set on `document.body`:

```
document.body.onclick = function(event) {
  console.log(event.currentTarget === document.body); // true
  console.log(this === document.body);              // true
  console.log(event.target === document.getElementById("myBtn")); // true
};
```

When the button is clicked in this example, both `this` and `currentTarget` are equal to `document.body` because that's where the event handler was registered. The `target` property, however, is equal to the button element itself, because that's the true target of the `click` event. Because the button itself doesn't have an event handler assigned, the `click` event bubbles up to `document.body`, where the event is handled.

The `type` property is useful when you want to assign a single function to handle multiple events. Here is an example which uses `event.type`:

```
let btn = document.getElementById("myBtn");
let handler = function(event) {
  switch(event.type) {
    case "click":
      console.log("Clicked");
      break;
    case "mouseover":
      event.target.style.backgroundColor = "red";
      break;
    case "mouseout":
      event.target.style.backgroundColor = "";
      break;
  }
};

btn.onclick = handler;
btn.onmouseover = handler;
btn.onmouseout = handler;
```

In this example, a single function called `handler` is defined to handle three different events: `click`, `mouseover`, and `mouseout`. When the button is clicked, it should log a message, as in the previous examples. When the mouse is moved over the button, the background color should change to red, and when the mouse is moved away from the button, the background color should revert to its default. Using the `event.type` property, the function is able to determine which event occurred and then react appropriately.

The `preventDefault()` method is used to prevent the default action of a particular event. The default behavior of a link, for example, is to navigate to the URL specified in its `href` attribute when clicked. If you want to prevent that navigation from occurring, an `onclick` event handler can cancel that behavior, as in the following example:

```
let link = document.getElementById("myLink");
link.onclick = function(event) {
  event.preventDefault();
};
```

Any event that can be canceled using `preventDefault()` will have its `cancelable` property set to `true`.

The `stopPropagation()` method stops the flow of an event through the DOM structure immediately, canceling any further event capturing or bubbling before it occurs. For example, an event handler added directly to a button can call `stopPropagation()` to prevent an event handler on `document.body` from being fired, as shown in the following example:

```
let btn = document.getElementById("myBtn");
btn.onclick = function(event) {
  console.log("Clicked");
  event.stopPropagation();
};

document.body.onclick = function(event) {
  console.log("Body clicked");
};
```

Without the call to `stopPropagation()` in this example, two messages would be logged when the button is clicked. However, the `click` event never reaches `document.body`, so the `onclick` event handler is never executed.

The `eventPhase` property aids in determining what phase of event flow is currently active. If the event handler is called during the capture phase, `eventPhase` is 1; if the event handler is at the target, `eventPhase` is 2; if the event handler is during the bubble phase, `eventPhase` is 3. Note that even though “at target” occurs during the bubbling phase, `eventPhase` is always 2. Here is an example showing the various `eventPhase` values:

```
let btn = document.getElementById("myBtn");
btn.onclick = function(event) {
  console.log(event.eventPhase); // 2
};

document.body.addEventListener("click", (event) => {
  console.log(event.eventPhase); // 1
}, true);

document.body.onclick = (event) => {
  console.log(event.eventPhase); // 3
};
```

When the button in this example is clicked, the first event handler to fire is the one on `document.body` in the capturing phase, which logs a message that displays 1 as the `eventPhase`. Next, the event handler on the button itself is fired, at which point the `eventPhase` is 2. The last event handler to fire

is during the bubbling phase on `document.body` when `eventPhase` is 3. Whenever `eventPhase` is 2, `this`, `target`, and `currentTarget` are always equal.

NOTE *The `event` object exists only while event handlers are still being executed; once all event handlers have been executed, the `event` object is destroyed.*

The Internet Explorer Event Object

Unlike the DOM event object, the legacy Internet Explorer event object is accessible in different ways, based on the way in which the event handler was assigned. When an event handler is assigned using the DOM Level 0 approach, the event object exists only as a property of the window object, as shown in this example:

```
var btn = document.getElementById("myBtn");
btn.onclick = function() {
  let event = window.event;
  console.log(event.type); // "click"
};
```

Here, the event object is retrieved from `window.event` and then used to determine the type of event that was fired (the `type` property for Internet Explorer is identical to that of the DOM version). However, if the event handler is assigned using `attachEvent()`, the event object is passed in as the sole argument to the function, as shown here:

```
var btn = document.getElementById("myBtn");
btn.attachEvent("onclick", function(event) {
  console.log(event.type); // "click"
});
```

When using `attachEvent()`, the event object is also available on the window object, as with the DOM Level 0 approach. It is also passed in as an argument for convenience.

If the event handler is assigned by an HTML attribute, the event object is available as a variable called `event` (the same as the DOM model). Here's an example using `event.type` inside the attribute:

```
<input type="button" value="Click Me" onclick="console.log(event.type)">
```

The Internet Explorer event object also contains properties and methods related to the specific event that caused its creation. Many of these either map directly to or are related to DOM properties or methods. Like the DOM event object, the available properties and methods differ based on the type of event that was fired, but all events use the properties and methods defined in the following table.

PROPERTY/METHOD	TYPE	READ/WRITE	DESCRIPTION
<code>cancelBubble</code>	Boolean	Read/Write	False by default, but can be set to <code>true</code> to cancel event bubbling (same as the DOM <code>stopPropagation()</code> method).

PROPERTY/METHOD	TYPE	READ/WRITE	DESCRIPTION
<code>returnValue</code>	Boolean	Read/Write	True by default, but can be set to false to cancel the default behavior of the event (same as the DOM <code>preventDefault()</code> method).
<code>srcElement</code>	Element	Read only	The target of the event (same as the DOM <code>target</code> property).
<code>type</code>	String	Read only	The type of event that was fired.

Because the scope of an event handler is determined by the manner in which it was assigned, the value of `this` cannot always be assumed to be equal to the event target, so it's a good idea to always use `event.srcElement` instead. Here is an example demonstrating this with two different event objects:

```
var btn = document.getElementById("myBtn");
btn.onclick = function() {
  console.log(window.event.srcElement === this); // true
};

btn.attachEvent("onclick", function(event) {
  console.log(event.srcElement === this); // false
});
```

In the first event handler, which is assigned using the DOM Level 0 approach, the `srcElement` property is equal to `this`, but in the second event handler, the two values are different.

The `returnValue` property is the equivalent of the DOM `preventDefault()` method in that it cancels the default behavior of a given event. You need only set `returnValue` to `false` to prevent the default action. Consider the following example which sets this property:

```
var link = document.getElementById("myLink");
link.onclick = function() {
  window.event.returnValue = false;
};
```

In this example, using `returnValue` in an `onclick` event handler stops a link's default action. Unlike the DOM, there is no way to determine whether an event can be canceled or not using JavaScript.

The `cancelBubble` property performs the same action as the DOM `stopPropagation()` method: it stops the event from bubbling. Because Internet Explorer 8 and earlier don't support the capturing phase, only bubbling is canceled, whereas `stopPropagation()` stops both capturing and bubbling. Here is an example demonstrating bubble canceling:

```
var btn = document.getElementById("myBtn");
btn.onclick = function() {
  console.log("Clicked");
  window.event.cancelBubble = true;
};

document.body.onclick = function() {
  console.log("Body clicked");
};
```

By setting `cancelBubble` to `true` in the button's `onclick` event handler, you prevent the event from bubbling up to the `document.body` event handler. The result is that only one message is displayed when the button is clicked.

The Cross-Browser Event Object

Although the `event` objects for the DOM and Internet Explorer are different, there are enough similarities to allow cross-browser solutions. All of the information and capabilities of the Internet Explorer `event` object are present in the DOM object, just in a different form. These parallels enable easy mapping from one event model to the other. The `EventUtil` object described earlier can be augmented with methods that equalize the differences:

```
var EventUtil = {
  addHandler: function(element, type, handler) {
    // code removed for printing
  },

  getEvent: function(event) {
    return event ? event : window.event;
  },

  getTarget: function(event) {
    return event.target || event.srcElement;
  },

  preventDefault: function(event) {
    if (event.preventDefault) {
      event.preventDefault();
    } else {
      event.returnValue = false;
    }
  },

  removeHandler: function(element, type, handler) {
    // code removed for printing
  },

  stopPropagation: function(event) {
    if (event.stopPropagation) {
      event.stopPropagation();
    } else {
      event.cancelBubble = true;
    }
  }
};
```

There are four new methods added to `EventUtil` in this code. The first is `getEvent()`, which returns a reference to the `event` object. Because the location of the `event` object differs in Internet Explorer, this method can be used to retrieve the `event` object regardless of the event handler assignment approach used. To use this method, you must assume that the `event` object is passed into the event

handler and pass in that variable to the method. Here is an example which uses the `EventUtil` to normalize the event object:

```
btn.onclick = function(event) {
    event = EventUtil.getEvent(event);
};
```

When used in a DOM-compliant browser, the `event` variable is just passed through and returned. In Internet Explorer the `event` argument will be undefined, so `window.event` is returned. Adding this line to the beginning of event handlers ensures that the `event` object is always available, regardless of the browser being used.

The second method is `getTarget()`, which returns the target of the event. Inside the method, it checks the event object to see if the `target` property is available and returns its value if it is; otherwise, the `srcElement` property is used. This method can be used as follows:

```
btn.onclick = function(event) {
    event = EventUtil.getEvent(event);
    let target = EventUtil.getTarget(event);
};
```

The third method is `preventDefault()`, which stops the default behavior of an event. When the event object is passed in, it is checked to see if the `preventDefault()` method is available and, if so, calls it. If `preventDefault()` is not available, the method sets `returnValue` to `false`, as shown in this example:

```
let link = document.getElementById("myLink");
link.onclick = function(event) {
    event = EventUtil.getEvent(event);
    EventUtil.preventDefault(event);
};
```

This code prevents a link click from navigating to another page in all major browsers. The event object is first retrieved using `EventUtil.getEvent()` and then passed into `EventUtil.preventDefault()` to stop the default behavior.

The fourth method, `stopPropagation()`, works in a similar way. It first tries to use the DOM method for stopping the event flow and uses `cancelBubble` if necessary. Here is an example of how `stopPropagation()` is used:

```
let btn = document.getElementById("myBtn");
btn.onclick = function(event) {
    console.log("Clicked");
    event = EventUtil.getEvent(event);
    EventUtil.stopPropagation(event);
};

document.body.onclick = function(event) {
    console.log("Body clicked");
};
```

Here, the event object is retrieved using `EventUtil.getEvent()` and then passed into `EventUtil.stopPropagation()`. Remember that this method may stop event bubbling or both event bubbling and capturing depending on the browser.

EVENT TYPES

There are numerous categories of events that can occur in a web browser. As mentioned previously, the type of event being fired determines the information that is available about the event. DOM Level 3 Events specifies the following event groups:

- **User interface (UI) events** are general browser events that may have some interaction with the BOM.
- **Focus events** are fired when an element gains or loses focus.
- **Mouse events** are fired when the mouse is used to perform an action on the page.
- **Wheel events** are fired when a mouse wheel (or similar device) is used.
- **Text events** are fired when text is input into the document.
- **Keyboard events** are fired when the keyboard is used to perform an action on the page.
- **Composition events** are fired when inputting characters for an Input Method Editor (IME).

In addition to these categories, HTML5 defines another set of events, and browsers often implement proprietary events both on the DOM and on the BOM. These proprietary events are typically driven by developer demand rather than specifications and so may be implemented differently across browsers.

DOM Level 3 Events redefines the event groupings from DOM Level 2 Events and adds additional event definitions. All major browsers support DOM Level 2 and 3 Events.

UI Events

UI events are those events that aren't necessarily related to user actions. These events existed in some form or another prior to the DOM specification and were retained for backwards compatibility. The UI events are as follows:

- **DOMActivate**—Fires when an element has been activated by some user action, by either mouse or keyboard (more generic than `click` or `keydown`). This event is deprecated in DOM Level 3 Events. Because of cross-browser implementation differences, avoid using this event.
- **load**—Fires on a window when the page has been completely loaded, on a frameset when all frames have been completely loaded, on an `` element when it has been completely loaded, or on an `<object>` element when it has been completely loaded.
- **unload**—Fires on a window when the page has been completely unloaded, on a frameset when all frames have been completely unloaded, or on an `<object>` element when it has been completely unloaded.
- **abort**—Fires on an `<object>` element if it is not fully loaded before the user stops the download process.
- **error**—Fires on a window when a JavaScript error occurs, on an `` element if the image specified cannot be loaded, on an `<object>` element if it cannot be loaded, or on a frameset if one or more frames cannot be loaded..

- `select`—Fires when the user selects one or more characters in a text box (either `<input>` or `<textarea>`).
- `resize`—Fires on a window or frame when it is resized.
- `scroll`—Fires on any element with a scrollbar when the user scrolls it. The `<body>` element contains the scrollbar for a loaded page.

Most of the HTML events are related either to the `window` object or to form controls.

With the exception of `DOMActivate`, these events were part of the HTML Events group in DOM Level 2 Events (`DOMActivate` was still part of UI Events in DOM Level 2). Note that browsers should return `true` for this only if they implement these events according to the DOM Level 2 Events. Browsers may support these events in nonstandard ways and thus return `false`.

The load Event

The `load` event is perhaps the most often used event in JavaScript. For the `window` object, the `load` event fires when the entire page has been loaded, including all external resources such as images, JavaScript files, and CSS files. You can define an `onload` event handler in two ways. The first is by using JavaScript, as shown here:

```
window.addEventListener("load", (event) => {
  console.log("Loaded!");
});
```

This is the JavaScript-based way of assigning an event handler, using the cross-browser `EventUtil` object discussed earlier in this chapter. As with other events, the `event` object is passed into the event handler. The `event` object doesn't provide any extra information for this type of event, although it's interesting to note that DOM-compliant browsers have `event.target` set to `document`, whereas Internet Explorer prior to version 8 doesn't set the `srcElement` property for this event.

The second way to assign the `onload` event handler is to add an `onload` attribute to the `<body>` element, as in the following example:

```
<!DOCTYPE html>
<html>
<head>
  <title>Load Event Example</title>
</head>
<body onload="console.log('Loaded!')">

</body>
</html>
```

Generally speaking, any events that occur on the `window` can be assigned via attributes on the `<body>` element because there is no access to the `window` element in HTML. This really is a hack for backwards compatibility but is still well-supported in all browsers. Use the JavaScript approach whenever possible.

NOTE According to DOM Level 2 Events, the `load` event is supposed to fire on `document`, not on `window`. However, `load` is implemented on `window` in all browsers for backwards compatibility.

The `load` event also fires on images, both those that are in the DOM and those that are not. You can assign an `onload` event handler directly using HTML on any images in the document, using code such as this:

```

```

This example logs a message when the given image has been loaded. This can also be done using JavaScript, as follows:

```
let image = document.getElementById("myImage");
image.addEventListener("load", (event) => {
  console.log(event.target.src);
});
```

Here, the `onload` event handler is assigned using JavaScript. The `event` object is passed in, though it doesn't have much useful information. The target of the event is the `` element, so its `src` property can be accessed and displayed.

When creating a new `` element, an event handler can be assigned to indicate when the image has been loaded. In this case, it's important to assign the event before assigning the `src` property, as in the following example:

```
window.addEventListener("load", () => {
  let image = document.createElement("img");
  image.addEventListener("load", (event) => {
    console.log(event.target.src);
  });
  document.body.appendChild(image);
  image.src = "smile.gif";
});
```

The first part of this example is to assign an `onload` event handler for the window. Because the example involves adding a new element to the DOM, you must be certain that the page is loaded, because trying to manipulate `document.body` prior to its being fully loaded can cause errors. A new `image` element is created and its `onload` event handler is set. Then, the image is added to the page and its `src` is assigned. Note that the element need not be added to the document for the image download to begin; it begins as soon as the `src` property is set.

This same technique can be used with the DOM Level 0 `Image` object. Prior to the DOM, the `Image` object was used to preload images on the client. It can be used the same way as an `` element with the exception that it cannot be added into the DOM tree. Consider the following example which instantiates a new `Image` object:

```
window.addEventListener("load", () => {
  let image = new Image();
  image.addEventListener("load", (event) => {
    console.log("Image loaded!");
  });
  image.src = "smile.gif";
});
```

Here, the `Image` constructor is used to create a new image and the event handler is assigned. Some browsers implement the `Image` object as an `` element, but not all, so it's best to treat them as separate.

NOTE *Internet Explorer 8 and earlier versions don't generate an event object when the `load` event fires for an image that isn't part of the DOM document. This pertains both to `` elements that are never added to the document and to the `Image` object. This was fixed in Internet Explorer 9.*

There are other elements that also support the `load` event in nonstandard ways. The `<script>` element fires a `load` event, allowing you to determine when dynamically loaded JavaScript files have been completely loaded. Unlike images, JavaScript files start downloading only after the `src` property has been assigned and the element has been added into the document, so the order in which the event handler and the `src` property are assigned is insignificant. The following illustrates how to assign an event handler for a `<script>` element:

```

window.addEventListener("load", () => {
  let script = document.createElement("script");
  script.addEventListener("load", (event) => {
    console.log("Loaded");
  });
  script.src = "example.js";
  document.body.appendChild(script);
});

```

The event object's target is the `<script>` node in most browsers. Internet Explorer 8 and earlier versions do not support the `load` event for `<script>` elements.

Internet Explorer and Opera support the `load` event for `<link>` elements, allowing you to determine when a style sheet has been loaded. The following example shows how a listener for this event can be set:

```

window.addEventListener("load", () => {
  let link = document.createElement("link");
  link.type = "text/css";
  link.rel = "stylesheet";
  link.addEventListener("load", (event) => {
    console.log("css loaded");
  });
  link.href = "example.css";
  document.getElementsByTagName("head")[0].appendChild(link);
});

```

As with the `<script>` node, a style sheet does not begin downloading until the `href` property has been assigned and the `<link>` element has been added to the document.

The unload Event

A companion to the `load` event, the `unload` event fires when a document has completely unloaded. The `unload` event typically fires when navigating from one page to another and is most often used to clean up references to avoid memory leaks. Similar to the `load` event, an `onunload` event handler can be assigned in two ways. The first is by using JavaScript, as shown here:

```

window.addEventListener("unload", (event) => {
  console.log("Unloaded!");
});

```

The event object is generated for this event but contains nothing more than the `target` (set to `document`) in DOM-compliant browsers. Internet Explorer 8 and earlier versions don't provide the `srcElement` property for this event.

The second way to assign the event handler, similar to the `load` event, is to add an attribute to the `<body>` element, as in this example:

```
<!DOCTYPE html>
<html>
<head>
  <title>Unload Event Example</title>
</head>
<body onunload="console.log('Unloaded!')">

</body>
</html>
```

Regardless of the approach you use, be careful with the code that executes inside of an `onunload` event handler. Because the `unload` event fires after everything is unloaded, not all objects that were available when the page was loaded are still available. Trying to manipulate the location of a DOM node or its appearance can result in errors.

NOTE *According to DOM Level 2 Events, the `unload` event is supposed to fire on `<body>`, not on `window`. However, `unload` is implemented on `window` in all browsers for backwards compatibility.*

The `resize` Event

When the browser window is resized to a new height or width, the `resize` event fires. This event fires on `window`, so an event handler can be assigned either via JavaScript or by using the `onresize` attribute on the `<body>` element. Prefer to use the JavaScript approach, as shown here:

```
window.addEventListener("resize", (event) => {
  console.log("Resized");
});
```

Similar to other events that occur on the `window`, the event object is created and its `target` is `document` in DOM-compliant browsers, whereas Internet Explorer 8 and earlier provide no properties of use.

There are some important differences as to when the `resize` events fire across browsers. Internet Explorer, Safari, Chrome, and Opera fire the `resize` event as soon as the browser is resized by one pixel and then repeatedly as the user resizes the browser window. Firefox fires the `resize` event only after the user has stopped resizing the browser. Because of these differences, you should avoid computation-heavy code in the event handler for this event because it will be executed frequently and cause a noticeable slowdown in the browser.

NOTE *The `resize` event also fires when the browser window is minimized or maximized.*

The scroll Event

Even though the `scroll` event occurs on the `window`, it actually refers to changes in the appropriate page-level element. In quirks mode, the changes are observable using the `scrollLeft` and `scrollTop` of the `<body>` element; in standards mode, the changes occur on the `<html>` element in all browsers except Safari (which still tracks scroll position on `<body>`). The following example shows how to properly handle this:

```
window.addEventListener("scroll", (event) => {
  if (document.compatMode == "CSS1Compat") {
    console.log(document.documentElement.scrollTop);
  } else {
    console.log(document.body.scrollTop);
  }
});
```

This code assigns an event handler that outputs the vertical scroll position of the page, depending on the rendering mode. Because Safari prior to 3.1 doesn't support `document.compatMode`, older versions fall through to the second case.

Similar to `resize`, the `scroll` event occurs repeatedly as the document is being scrolled, so it's best to keep the event handlers as simple as possible.

Focus Events

Focus events are fired when elements of a page receive or lose focus. These events work in concert with the `document.hasFocus()` and `document.activeElement` properties to give insight as to how the user is navigating the page. There are six focus events:

- `blur`—Fires when an element has lost focus. This event does not bubble and is supported in all browsers.
- `DOMFocusIn`—Fires when an element has received focus. This is a bubbling version of the `focus` HTML event. Opera is the only major browser to support this event. DOM Level 3 Events deprecates `DOMFocusIn` in favor of `focusin`.
- `DOMFocusOut`—Fires when an element has lost focus. This is a generic version of the `blur` HTML event. Opera is the only major browser to support this event. DOM Level 3 Events deprecates `DOMFocusOut` in favor of `focusout`.
- `focus`—Fires when an element has received focus. This event does not bubble and is supported in all browsers.
- `focusin`—Fires when an element has received focus. This is a bubbling version of the `focus` HTML event.
- `focusout`—Fires when an element has lost focus. This is a generic version of the `blur` HTML event.

The two primary events of this group are `focus` and `blur`, both of which have been supported in browsers since the early days of JavaScript. One of the biggest issues with these events is that they don't bubble. This led to the inclusion of `focusin` and `focusout` by Internet Explorer and `DOMFocusIn` and `DOMFocusOut` by Opera. Internet Explorer's approach has been standardized in DOM Level 3 Events.

When focus is moved from one element to another on the page, the order of events is as follows:

1. `focusout` fires on the element losing focus.
2. `focusin` fires on the element receiving focus.
3. `blur` fires on the element losing focus.
4. `DOMFocusOut` fires on the element losing focus.
5. `focus` fires on the element receiving focus.
6. `DOMFocusIn` fires on the element receiving focus.

The event target for `blur`, `DOMFocusOut`, and `focusout` is the element losing focus while the event target for `focus`, `DOMFocusIn`, and `focusin` is the element receiving focus.

Mouse and Wheel Events

Mouse events are the most commonly used group of events on the Web, because the mouse is the primary navigation device used. There are nine mouse events defined in DOM Level 3 Events. They are as follows:

- `click`—Fires when the user clicks the primary mouse button (typically the left button) or when the user presses the Enter key. This is an important fact for accessibility purposes, because `onclick` event handlers can be executed using the keyboard and the mouse.
- `dblclick`—Fires when the user double-clicks the primary mouse button (typically the left button). This event was not defined in DOM Level 2 Events but is well-supported and so was standardized in DOM Level 3 Events.
- `mousedown`—Fires when the user pushes any mouse button down. This event cannot be fired via the keyboard.
- `mouseenter`—Fires when the mouse cursor is outside of an element and then the user first moves it inside of the boundaries of the element. This event does not bubble and does not fire when the cursor moves over descendant elements. The `mouseenter` event was not defined in DOM Level 2 Events but was added in DOM Level 3 Events.
- `mouseleave`—Fires when the mouse cursor is over an element and then the user moves it outside of that element's boundaries. This event does not bubble and does not fire when the cursor moves over descendant elements. The `mouseleave` event was not defined in DOM Level 2 Events but was added in DOM Level 3 Events.
- `mousemove`—Fires repeatedly as the cursor is being moved around an element. This event cannot be fired via the keyboard.
- `mouseout`—Fires when the mouse cursor is over an element and then the user moves it over another element. The element moved to may be outside of the bounds of the original element or a child of the original element. This event cannot be fired via the keyboard.

- `mouseover`—Fires when the mouse cursor is outside of an element and then the user first moves it inside of the boundaries of the element. This event cannot be fired via the keyboard.
- `mouseup`—Fires when the user releases a mouse button. This event cannot be fired via the keyboard.

All elements on a page support mouse events. All mouse events bubble except `mouseenter` and `mouseleave`, and they can all be canceled, which affects the default behavior of the browser.

Canceling the default behavior of mouse events can affect other events as well because of the relationship that exists amongst the events.

A `click` event can be fired only if a `mousedown` event is fired and followed by a `mouseup` event on the same element; if either `mousedown` or `mouseup` is canceled, then the `click` event will not fire. Similarly, it takes two `click` events to cause the `dblclick` event to fire. If anything prevents these two `click` events from firing (either canceling one of the `click` events or canceling either `mousedown` or `mouseup`), the `dblclick` event will not fire. These four mouse events always fire in the following order:

1. `mousedown`
2. `mouseup`
3. `click`
4. `mousedown`
5. `mouseup`
6. `click`
7. `dblclick`

Both `click` and `dblclick` rely on other events to fire before they can fire, whereas `mousedown` and `mouseup` are not affected by other events.

Internet Explorer through version 8 has a slight implementation bug that causes the second `mousedown` and `click` events to be skipped during a double click. The order is:

1. `mousedown`
2. `mouseup`
3. `click`
4. `mouseup`
5. `dblclick`

Note that the DOM Level 3 feature name is just "MouseEvent" instead of "MouseEvents".

There is also a subgroup of mouse events called *wheel events*. Wheel events are really just a single event, `mousewheel`, which monitors interactions of a mouse wheel or a similar device such as the Mac trackpad.

Client Coordinates

Mouse events all occur at a particular location within the browser viewport. This information is stored in the `clientX` and `clientY` properties of the event object. These properties indicate the location of the mouse cursor within the viewport at the time of the event and are supported in all browsers. Figure 17-4 illustrates the *client coordinates* in a viewport.

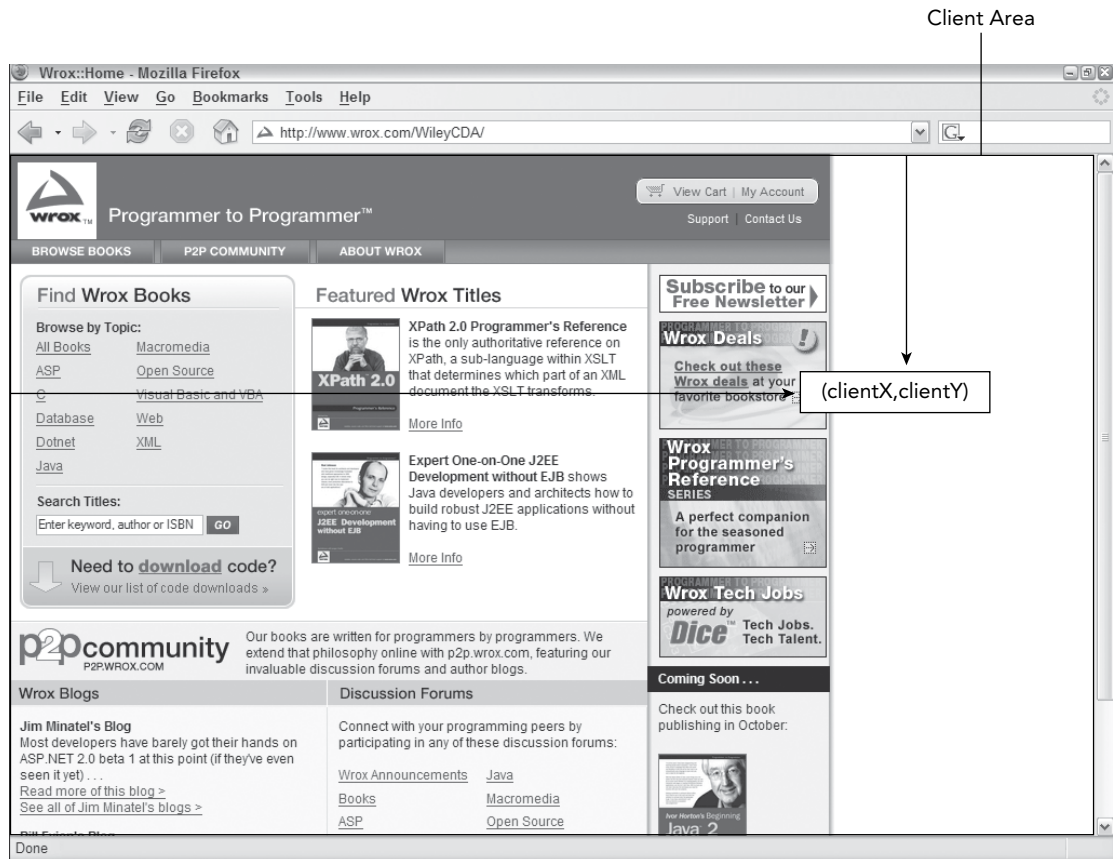

FIGURE 17-4:

You can retrieve the client coordinates of a mouse event in the following way:

```
let div = document.getElementById("myDiv");
div.addEventListener("click", (event) => {
  console.log(`Client coordinates: ${event.clientX}, ${event.clientY}`);
});
```

This example assigns an `onclick` event handler to a `<div>` element. When the element is clicked, the client coordinates of the event are displayed. Keep in mind that these coordinates do not take into account the scroll position of the page, so these numbers do not indicate the location of the cursor on the page.

Page Coordinates

Where client coordinates give you information about where an event occurred in the viewport, *page coordinates* tell you where on the page the event occurred via the `pageX` and `pageY` properties of the event object. These properties indicate the location of the mouse cursor on the page, so the coordinates are from the left and top of the page itself rather than the viewport.

You can retrieve the page coordinates of a mouse event in the following way:

```
let div = document.getElementById("myDiv");
div.addEventListener("click", (event) => {
  console.log(`Page coordinates: ${event.pageX}, ${event.pageY}`);
});
```

The values for `pageX` and `pageY` are the same as `clientX` and `clientY` when the page is not scrolled.

Internet Explorer 8 and earlier don't support page coordinates on the event object, but you can calculate them using client coordinates and scrolling information. You need to use the `scrollLeft` and `scrollTop` properties on either `document.body` (when in quirks mode) or `document.documentElement` (in standards mode). The calculation is done as follows:

```
let div = document.getElementById("myDiv");
div.addEventListener("click", (event) => {
  let pageX = event.pageX,
      pageY = event.pageY;
  if (pageX === undefined) {
    pageX = event.clientX + (document.body.scrollLeft ||
      document.documentElement.scrollLeft);
  }
  if (pageY === undefined) {
    pageY = event.clientY + (document.body.scrollTop ||
      document.documentElement.scrollTop);
  }
  console.log(`Page coordinates: ${pageX}, ${pageY}`);
});
```

Screen Coordinates

Mouse events occur not only in relation to the browser window but also in relation to the entire screen. It's possible to determine the location of the mouse in relation to the entire screen by using the `screenX` and `screenY` properties. Figure 17-5 illustrates the *screen coordinates* in a browser.

You can retrieve the screen coordinates of a mouse event in the following way:

```
let div = document.getElementById("myDiv");
div.addEventListener("click", (event) => {
  console.log(`Screen coordinates: ${event.screenX}, ${event.screenY}`);
});
```

Similar to the previous examples, this code assigns an `onclick` event handler to a `<div>` element. When the element is clicked, the screen coordinates of the event are displayed.

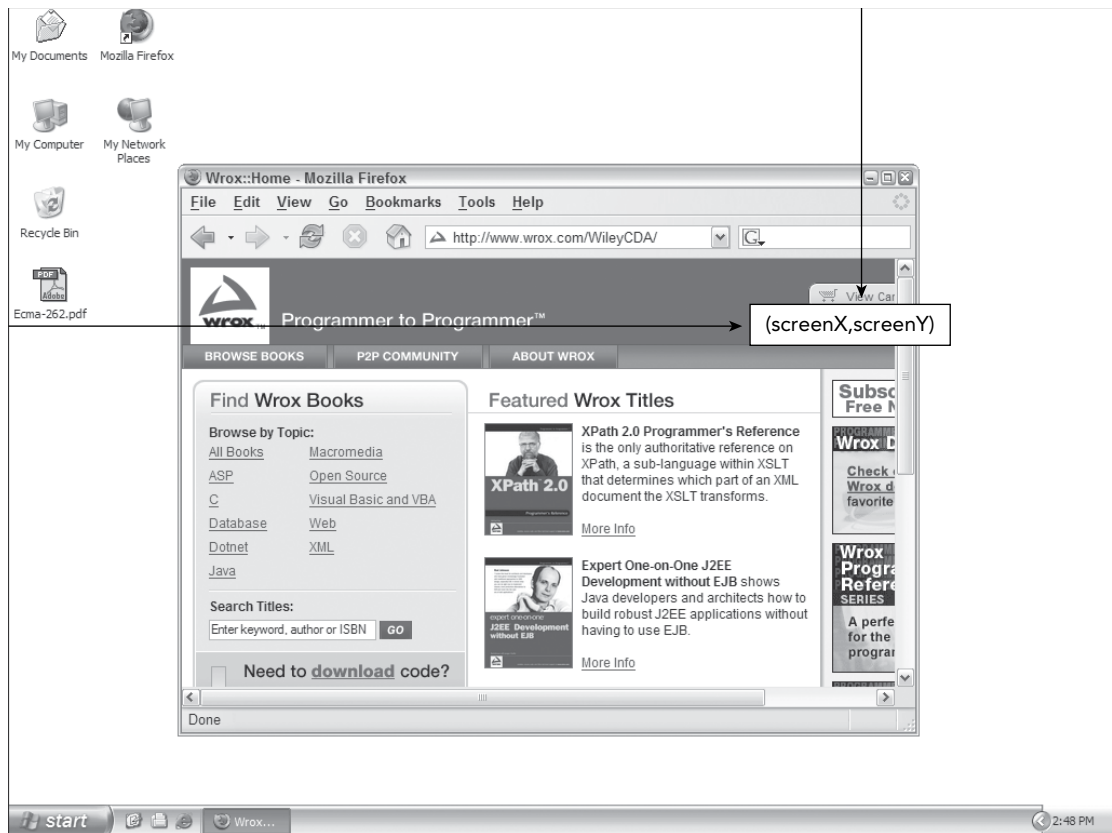

FIGURE 17-5:

Modifier Keys

Even though a mouse event is primarily triggered by using the mouse, the state of certain keyboard keys may be important in determining the action to take. The *modifier keys* Shift, Ctrl, Alt, and Meta are often used to alter the behavior of a mouse event. The DOM specifies four properties to indicate the state of these modifier keys: `shiftKey`, `ctrlKey`, `altKey`, and `metaKey`. Each of these properties contains a Boolean value that is set to `true` if the key is being held down or `false` if the key is not pressed. When a mouse event occurs, you can determine the state of the various keys by inspecting these properties. Consider the following example, which checks for modifier key state when a `click` event is fired:

```
let div = document.getElementById("myDiv");
div.addEventListener("click", (event) => {
  let keys = new Array();

  if (event.shiftKey) {
    keys.push("shift");
  }
});
```

```

    if (event.ctrlKey) {
        keys.push("ctrl");
    }

    if (event.altKey) {
        keys.push("alt");
    }

    if (event.metaKey) {
        keys.push("meta");
    }

    console.log("Keys: " + keys.join(", "));

});

```

In this example, an `onclick` event handler checks the state of the various modifier keys. The `keys` array contains the names of the modifier keys that are being held down. For each property that is `true`, the name of the key is added to `keys`. At the end of the event handler, the keys are displayed in a log message.

NOTE *Modern browsers support all four keys. Internet Explorer 8 and earlier versions do not support the `metaKey` property.*

Related Elements

For the `mouseover` and `mouseout` events, there are other elements related to the event. Both of these events involve moving the mouse cursor from within the boundaries of one element to within the boundaries of another element. For the `mouseover` event, the primary target of the event is the element that is gaining the cursor, and the related element is the one that is losing the cursor. Likewise, for `mouseout`, the primary target is the element that is losing the cursor, and the related element is the one that is gaining the cursor. Consider the following example:

```

<!DOCTYPE html>
<html>
<head>
  <title>Related Elements Example</title>
</head>
<body>
  <div id="myDiv"
    style="background-color:red;height:100px;width:100px;"></div>
</body>
</html>

```

This page renders a single `<div>` on the page. If the mouse cursor starts over the `<div>` and then moves outside of it, a `mouseout` event fires on `<div>` and the related element is the `<body>` element. Simultaneously, the `mouseover` event fires on `<body>` and the related element is the `<div>`.

The DOM provides information about related elements via the `relatedTarget` property on the event object. This property contains a value only for the `mouseover` and `mouseout` events; it is `null`

for all other events. Internet Explorer 8 and earlier don't support the `relatedTarget` property but offer comparable access to the related element using other properties. When the `mouseover` event fires, Internet Explorer provides a `fromElement` property containing the related element; when the `mouseout` event fires, Internet Explorer provides a `toElement` property containing the related element (Internet Explorer 9 supports all properties). A cross-browser method to get the related element can be added to `EventUtil` like this:

```
var EventUtil = {
    // more code here

    getRelatedTarget: function(event) {
        if (event.relatedTarget) {
            return event.relatedTarget;
        } else if (event.toElement) {
            return event.toElement;
        } else if (event.fromElement) {
            return event.fromElement;
        } else {
            return null;
        }
    },

    // more code here
};
```

As with the previous cross-browser methods, this one uses feature detection to determine which value to return. The `EventUtil.getRelatedTarget()` method can then be used as follows:

```
let div = document.getElementById("myDiv");
div.addEventListener("mouseout", (event) => {
    let target = event.target;
    let relatedTarget = EventUtil.getRelatedTarget(event);
    console.log(
        `Moused out of ${target.tagName} to ${relatedTarget.tagName}`);
});
```

This example registers an event handler for the `mouseout` event on the `<div>` element. When the event fires, a message is logged indicating the place the mouse moved from and the place the mouse moved to.

Buttons

The `click` event is fired only when the primary mouse button is clicked on an element (or when the Enter key is pressed on the keyboard), so button information isn't necessary. For the `mousedown` and `mouseup` events, there is a `button` property on the event object that indicates the button that was pressed or released. The DOM `button` property has the following three possible values: 0 for the primary mouse button, 1 for the middle mouse button (usually the scroll wheel button), and 2 for the secondary mouse button. In traditional setups, the primary mouse button is the left button and the secondary button is the right one.

Internet Explorer through version 8 also provides a `button` property, but it has completely different values, as described here:

- 0 indicates that no button has been pressed.
- 1 indicates that the primary mouse button has been pressed.
- 2 indicates that the secondary mouse button has been pressed.
- 3 indicates that the primary and secondary buttons have been pressed.
- 4 indicates that the middle button has been pressed.
- 5 indicates that the primary and middle buttons have been pressed.
- 6 indicates that the secondary and middle buttons have been pressed.
- 7 indicates that all three buttons have been pressed.

As you can tell, the DOM model for the `button` property is much simpler and arguably more useful than the Internet Explorer model because multi-button mouse usage is rare. It's typical to normalize the models to the DOM way because all browsers except Internet Explorer 8 and earlier implement it natively. The mapping of primary, middle, and secondary buttons is fairly straightforward; all of the other Internet Explorer options will translate into the pressing of one of the buttons, giving precedence to the primary button in all instances. So if Internet Explorer returns either 5 or 7, this converts to 0 in the DOM model.

Additional Event Information

The DOM Level 2 Events specification provides the `detail` property on the `event` object to give additional information about an event. For mouse events, `detail` contains a number indicating how many times a click has occurred at the given location. Clicks are considered to be a `mousedown` event followed by a `mouseup` event at the same pixel location. The value of `detail` starts at 1 and is incremented every time a click occurs. If the mouse is moved between `mousedown` and `mouseup`, then `detail` is set back to 0.

Internet Explorer provides the following additional information for each mouse event as well:

- `altLeft` is a Boolean value indicating if the left Alt key is pressed. If `altLeft` is `true`, then `altKey` is also `true`.
- `ctrlLeft` is a Boolean value indicating if the left Ctrl key is pressed. If `ctrlLeft` is `true`, then `ctrlKey` is also `true`.
- `offsetX` is the x-coordinate of the cursor relative to the boundaries of the target element.
- `offsetY` is the y-coordinate of the cursor relative to the boundaries of the target element.
- `shiftLeft` is a Boolean value indicating if the left Shift key is pressed. If `shiftLeft` is `true`, then `shiftKey` is also `true`.

These properties are of limited value because they are available only in Internet Explorer and provide information that either is not necessary or can be calculated in other ways.

The mousewheel Event

Internet Explorer 6 first implemented the `mousewheel` event. Since that time, it has been picked up by Opera, Chrome, and Safari. The `mousewheel` event fires when the user interacts with the mouse wheel, rolling it vertically in either direction. This event fires on each element and bubbles up to `document` (in Internet Explorer 8) and `window` on modern browsers. The event object for the `mousewheel` event contains all standard information about mouse events and an additional property called `wheelDelta`. When the mouse wheel is rolled toward the front of the mouse, `wheelDelta` is a positive multiple of 120; when the mouse wheel is rolled toward the rear of the mouse, `wheelDelta` is a negative multiple of 120. See Figure 17-6.

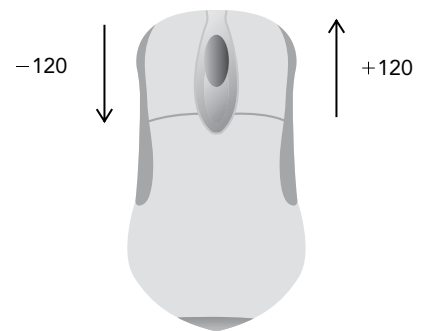

FIGURE 17-6:

An `onmousewheel` event handler can be assigned to any element on the page or to the document to handle all mouse wheel interactions. Here's an example:

```
document.addEventListener("mousewheel", (event) => {
  console.log(event.wheelDelta);
});
```

This example simply displays the `wheelDelta` value when the event is fired. In most cases, you need only know which direction the mouse wheel was turned, which can easily be determined by the sign of the `wheelDelta` value.

NOTE *The `mousewheel` event was added to HTML5 as a reflection of its popularity and availability in most browsers.*

Touch Device Support

Touch devices running iOS or Android have interesting implementations because, of course, there is no mouse to interact with. When developing for touch devices, keep the following in mind:

- The `dblclick` event is not supported at all. Double-clicking on the browser window zooms in, and there is no way to override that behavior.
- Tapping on a clickable element causes the `mousemove` event to fire. If content changes as a result of this action, no further events are fired; if there are no changes to the screen, then the `mousedown`, `mouseup`, and `click` events fire in order. No events are fired when tapping on a nonclickable element. Clickable elements are defined as those that have a default action when clicked (such as links) or elements that have an `onclick` event handler assigned.
- The `mousemove` event also fires `mouseover` and `mouseout` events.
- The `mousewheel` and `scroll` events fire when two fingers are on the screen and the page is scrolled as the result of finger movement.

Accessibility Issues

If your web application or website must be accessible to users with disabilities, specifically those who are using screen readers, you should be careful when using mouse events. As mentioned previously, the `click` event can be fired using the Enter key on the keyboard, but other mouse events have no keyboard support. It's advisable not to use mouse events other than `click` to show functionality or cause code execution, as this will severely limit the usability for blind or sight-impaired users. Here are some tips for accessibility using mouse events:

- Use `click` to execute code. Some suggest that an application feels faster when code is executed using `mousedown`, which is true for sighted users. For screen readers, however, this code is not accessible, because the `mousedown` event cannot be triggered.
- Avoid using `mouseover` to display new options to the user. Once again, screen readers have no way to trigger this event. If you really must display new options in this manner, consider adding keyboard shortcuts to display the same information.
- Avoid using `dblclick` to execute important actions. The keyboard cannot fire this event.

Following these simple hints can greatly increase the accessibility of your web application or website to those with disabilities.

NOTE *To learn more about accessibility on web pages, please visit www.webaim.org.*

Keyboard and Text Events

Keyboard events are fired when the user interacts with the keyboard. DOM Level 2 Events originally specified keyboard events, but that section was removed before the specification became final. As a result, keyboard events are largely supported based on the original DOM Level 0 implementations.

DOM Level 3 Events provides a specification for keyboard events that was first completely implemented in Internet Explorer 9. Other browsers have also started work on implementing the standard, but there are still many legacy implementations.

There are three keyboard events, as described here:

- `keydown`—Fires when the user presses a key on the keyboard and fires repeatedly while the key is being held down.
- `keypress`—Fires when the user presses a key on the keyboard that results in a character and fires repeatedly while the key is being held down. This event also fires for the Esc key. DOM Level 3 Events deprecates the `keypress` event in favor of the `textInput` event.
- `keyup`—Fires when the user releases a key on the keyboard.

These events are most easily seen as the user types in a text box, though all elements support them.

There is only one text event and it is called `textInput`. This event is an augmentation of `keypress` intended to make it easier to intercept text input before being displayed to the user. The `textInput` event fires just before text is inserted into a text box.

When the user presses a character key once on the keyboard, the `keydown` event is fired first, followed by the `keypress` event, followed by the `keyup` event. Note that both `keydown` and `keypress` are fired before any change has been made to the text box, whereas the `keyup` event fires after changes have been made to the text box. If a character key is pressed and held down, `keydown` and `keypress` are fired repeatedly and don't stop until the key is released.

For noncharacter keys, a single key press on the keyboard results in the `keydown` event being fired followed by the `keyup` event. If a noncharacter key is held down, the `keydown` event fires repeatedly until the key is released, at which point the `keyup` event fires.

NOTE *Keyboard events support the same set of modifier keys as mouse events. The `shiftKey`, `ctrlKey`, `altKey`, and `metaKey` properties are all available for keyboard events. Internet Explorer 8 and earlier do not support `metaKey`.*

Key Codes

For `keydown` and `keyup` events, the event object's `keyCode` property is filled in with a code that maps to a specific key on the keyboard. For alphanumeric keys, the `keyCode` is the same as the ASCII value for the lowercase letter or number on that key, so the 7 key has a `keyCode` of 55 and the A key has a `keyCode` of 65, regardless of the state of the Shift key. Both the DOM and the Internet Explorer event objects support the `keyCode` property. Here's an example demonstrating inspection of the `keyCode` property:

```
let textbox = document.getElementById("myText");
textbox.addEventListener("keyup", (event) => {
  console.log(event.keyCode);
});
```

In this example, the `keyCode` is displayed every time a `keyup` event is fired. The complete list of key codes to noncharacter keys is listed in the following table.

KEY	KEY CODE	KEY	KEY CODE
Backspace	8	Numpad 8	104
Tab	9	Numpad 9	105
Enter	13	Numpad +	107
Shift	16	Minus (both Numpad and not)	109
Ctrl	17	Numpad .	110
Alt	18	Numpad /	111
Pause/Break	19	F1	112

KEY	KEY CODE	KEY	KEY CODE
Caps Lock	20	F2	113
Esc	27	F3	114
Page Up	33	F4	115
Page Down	34	F5	116
End	35	F6	117
Home	36	F7	118
Left Arrow	37	F8	119
Up Arrow	38	F9	120
Right Arrow	39	F10	121
Down Arrow	40	F11	122
Ins	45	F12	123
Del	46	Num Lock	144
Left Windows Key	91	Scroll Lock	145
Right Windows Key	92	Semicolon (IE/Safari/Chrome)	186
Context Menu Key	93	Semicolon (Opera/FF)	59
Numpad 0	96	Less than	188
Numpad 1	97	Greater than	190
Numpad 2	98	Forward slash	191
Numpad 3	99	Grave accent (')	192
Numpad 4	100	Equals	61
Numpad 5	101	Left Bracket	219
Numpad 6	102	Back slash (\)	220
Numpad 7	103	Right Bracket	221
		Single Quote	222

Character Codes

When a `keypress` event occurs, this means that the key affects the display of text on the screen. All browsers fire the `keypress` event for keys that insert or remove a character; other keys are browser-dependent. Because the DOM Level 3 Events specification has only started being implemented, there are significant implementation differences across browsers.

Browsers support a property on the `event` object called `charCode`, which is filled in only for the `keypress` event and contains the ASCII code for the character related to the key that was pressed. In this case, the `keyCode` is typically equal to 0 or may also be equal to the key code for the key that was pressed. Internet Explorer 8 and earlier and Opera use `keyCode` to communicate the ASCII code for the character. To retrieve the character code in a cross-browser way, you must therefore first check to see if the `charCode` property is used and, if not, use `keyCode` instead, as shown in the following example:

```
var EventUtil = {
    // more code here

    getCharCode: function(event) {
        if (typeof event.charCode == "number") {
            return event.charCode;
        } else {
            return event.keyCode;
        }
    },
    // more code here
};
```

This method checks to see if the `charCode` property is a number (it will be undefined for browsers that don't support it) and, if it is, returns the value. Otherwise, the `keyCode` value is returned. This method can be used as follows:

```
let textbox = document.getElementById("myText");
textbox.addEventListener("keypress", (event) => {
    console.log(EventUtil.getCharCode(event));
});
```

Once you have the character code, it's possible to convert it to the actual character using the `String.fromCharCode()` method.

DOM Level 3 Changes

Although all browsers implement some form of keyboard events, DOM Level 3 Events makes several changes. The `charCode` property, for instance, isn't part of the DOM Level 3 Events specification for keyboard events. Instead, the specification defines two additional properties: `key` and `char`.

The `key` property is intended as a replacement for `keyCode` and contains a string. When a character key is pressed, the value of `key` is equal to the text character (for example, "k" or "M"); when a non-character key is pressed, the value of `key` is the name of the key (for example, "Shift" or "Down"). The `char` property behaves the same as `key` when a character key is pressed and is set to `null` when a noncharacter key is pressed.

Internet Explorer supports the `key` property but not the `char` property. Safari and Chrome support a property called `keyIdentifier` that returns the same value that `key` would in the case of noncharacter keys (such as Shift). For character keys, `keyIdentifier` returns the character code as a string in the format "U+0000" to indicate the Unicode value.

```

let textbox = document.getElementById("myText");
textbox.addEventListener("keypress", (event) => {
  let identifier = event.key || event.keyIdentifier;
  if (identifier) {
    console.log(identifier);
  }
});

```

Because of the lack of cross-browser support, it's not recommended to use `key`, `keyIdentifier`, or `char`.

DOM Level 3 Events also adds a property called `location`, which is a numeric value indicating where the key was pressed. Possible values are 0 for default keyboard, 1 for left location (such as the left Alt key), 2 for the right location (such as the right Shift key), 3 for the numeric keypad, 4 for mobile (indicating a virtual keypad), or 5 for joystick (such as the Nintendo Wii controller). Internet Explorer 9 supports this property. Safari and Chrome support an identical property called `keyLocation`, but because of a bug, the value is always 0 unless the key is on the numeric keypad (in which case it's 3); the value is never 1, 2, 4, or 5.

```

let textbox = document.getElementById("myText");
textbox.addEventListener("keypress", (event) => {
  let loc = event.location || event.keyLocation;
  if (loc) {
    console.log(loc);
  }
});

```

As with the `key` property, the `location` property isn't widely supported and so isn't recommended for cross-browser development.

The last addition to the event object is the `getModifierState()` method. This method accepts a single argument, a string equal to `Shift`, `Control`, `Alt`, `AltGraph`, or `Meta`, which indicates the modifier key to check. The method returns `true` if the given modifier is active (the key is being held down) or `false` if not:

```

let textbox = document.getElementById("myText");
textbox.addEventListener("keypress", (event) => {
  if (event.getModifierState) {
    console.log(event.getModifierState("Shift"));
  }
});

```

You can retrieve some of this information already using the `shiftKey`, `altKey`, `ctrlKey`, and `metaKey` properties on the event object.

The textInput Event

The DOM Level 3 Events specification introduced an event called `textInput` that fires when a character is input to an editable area. Designed as a replacement for `keypress`, a `textInput` event behaves somewhat differently. One difference is that `keypress` fires on any element that can have focus but `textInput` fires only on editable areas. Another difference is that `textInput` fires only for keys that result in a new character being inserted, whereas `keypress` fires for keys that affect text in any way (including Backspace).

Because the `textInput` event is interested primarily in characters, it provides a `data` property on the event object that contains the character that was inserted (not the character code). The value of `data` is always the exact character that was inserted, so if the S key is pressed without Shift, `data` is "s", but if the same key is pressed holding Shift down, then `data` is "S".

The `textInput` event can be used as follows:

```
let textbox = document.getElementById("myText");
textbox.addEventListener("textInput", (event) => {
  console.log(event.data);
});
```

In this example, the character that was inserted into the text box is displayed in a log message.

There is another property, on the event object, called `inputMethod` that indicates how the text was input into the control. The possible values are:

- 0 indicates the browser couldn't determine how the input was entered.
- 1 indicates a keyboard was used.
- 2 indicates the text was pasted in.
- 3 indicates the text was dropped in as part of a drag operation.
- 4 indicates the text was input using an IME.
- 5 indicates the text was input by selecting an option in a form.
- 6 indicates the text was input by handwriting (such as with a stylus).
- 7 indicates the text was input by voice command.
- 8 indicates the text was input by a combination of methods.
- 9 indicates the text was input by script.

Using this property, you can determine how text was input into a control in order to verify its validity.

Keyboard Events on Devices

The Nintendo Wii fires keyboard events when buttons are pressed on a Wii remote. Although you can't access all of the buttons on the Wii remote, there are several that fire keyboard events. Figure 17-7 illustrates the key codes that indicate particular buttons being pressed.

Keyboard events are fired when the crosspad (keycodes 175–178), minus (170), plus (174), 1 (172), or 2 (173) buttons are pressed. There is no way to tell if the power button, A, B, or Home button has been pressed.

Mobile touch devices fire keyboard events when using the onscreen keyboard.

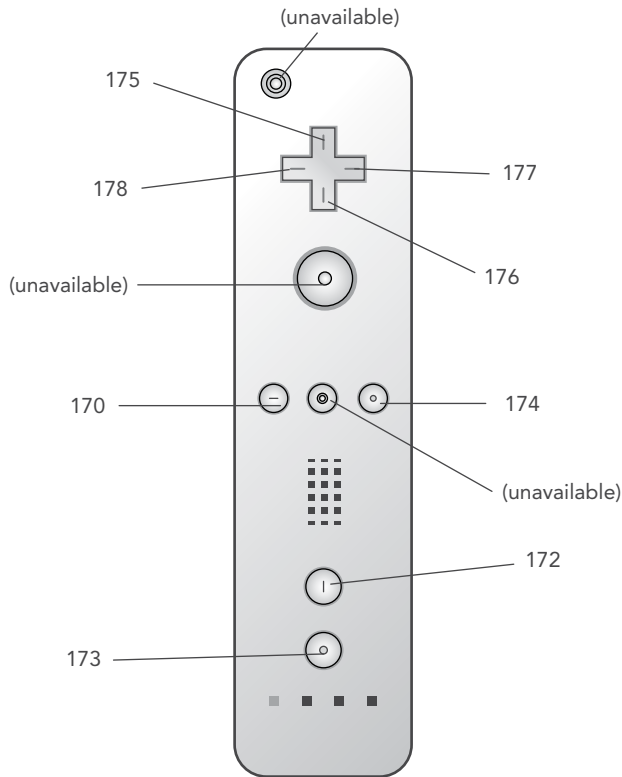

FIGURE 17-7:

Composition Events

Composition events were first introduced in DOM Level 3 Events to handle complex input sequences typically found on IMEs. IMEs allow users to input characters not found on the physical keyboard. For example, those using a Latin keyboard can still enter Japanese characters into the computer. IMEs often require multiple keys to be pressed at once while resulting in only a single character being entered. Composition events help to detect and work with such input. There are three composition events:

- `compositionstart`—Fires when the text composition system of the IME is opened, indicating that input is about to commence.
- `compositionupdate`—Fires when a new character has been inserted into the input field.
- `compositionend`—Fires when the text composition system is closed, indicating a return to normal keyboard input.

Composition events are similar to text events in many ways. When a composition event fires, the target is the input field receiving the text. The only additional event property is `data`, which contains one of the following:

- When accessed during `compositionstart`, contains the text being edited (for instance, if text has been selected and will now be replaced).

- When accessed during `compositionupdate`, contains the new character being inserted.
- When accessed during `compositionend`, contains all of the input entered during this composition session.

As with text events, composition events can be used to filter input where necessary. These events can be used as follows:

```
let textbox = document.getElementById("myText");
textbox.addEventListener("compositionstart", (event) => {
  console.log(event.data);
});
textbox.addEventListener("compositionupdate", (event) => {
  console.log(event.data);
});
textbox.addEventListener("compositionend", (event) => {
  console.log(event.data);
});
```

Mutation Events

The DOM Level 2 *mutation events* were designed to provide notification when a part of the DOM has been changed.

NOTE *These events are deprecated, and support is gradually being phased out. This feature is replaced by Mutation Observers, which is covered in The Document Object Model chapter.*

HTML5 Events

The DOM specification doesn't cover all events that are supported by all browsers. Many browsers have implemented custom events for various purposes based on either user need or a specific use case. HTML5 has an exhaustive list of all events that should be supported by browsers. This section discusses several events in HTML5 that are well supported by browsers. Note that this is not an exhaustive list of all events the browser supports. (Other events will be discussed throughout this book.)

The contextmenu Event

Windows 95 introduced the concept of context menus to PC users via a right mouse click. Soon, that paradigm was being mimicked on the Web. The problem developers were facing was how to detect that a context menu should be displayed (in Windows, it's a right click; on a Mac, it's a Ctrl+click) and then how to avoid the default context menu for the action. This resulted in the introduction of the `contextmenu` event to specifically indicate when a context menu is about to be displayed, allowing developers to cancel the default context menu and provide their own.

The `contextmenu` event bubbles, so a single event handler can be assigned to a document that handles all such events for the page. The target of the event is the element that was acted on. This event can be canceled in all browsers, using `event.preventDefault()` in DOM-compliant browsers and

setting `event.returnValue` to `false` in Internet Explorer 8 and earlier. The `contextmenu` event is considered a mouse event and so has all of the properties related to the cursor position. Typically, a custom context menu is displayed using an `oncontextmenu` event handler and hidden again using the `onclick` event handler. Consider the following HTML page:

```
<!DOCTYPE html>
<html>
<head>
  <title>ContextMenu Event Example</title>
</head>
<body>
  <div id="myDiv">Right click or Ctrl+click me to get a custom context menu.
    Click anywhere else to get the default context menu.</div>
  <ul id="myMenu" style="position:absolute;visibility:hidden;background-color:
    silver">
    <li><a href="http://www.nczonline.net">Nicholas' site</a></li>
    <li><a href="http://www.wrox.com">Wrox site</a></li>
    <li><a href="http://www.yahoo.com">Yahoo!</a></li>
  </ul>
</body>
</html>
```

In this code, a `<div>` is created that has a custom context menu. The `` element serves as the custom context menu and is initially hidden. The JavaScript to make this example work is as follows:

```
window.addEventListener("load", (event) => {
  let div = document.getElementById("myDiv");

  div.addEventListener("contextmenu", (event) => {
    event.preventDefault();

    let menu = document.getElementById("myMenu");
    menu.style.left = event.clientX + "px";
    menu.style.top = event.clientY + "px";
    menu.style.visibility = "visible";
  });

  document.addEventListener("click", (event) => {
    document.getElementById("myMenu").style.visibility = "hidden";
  });
});
```

Here, an `oncontextmenu` event handler is defined for the `<div>`. The event handler begins by canceling the default behavior, ensuring that the browser's context menu won't be displayed. Next, the `` element is placed into position based on the `clientX` and `clientY` properties of the event object. The last step is to show the menu by setting its `visibility` to `"visible"`. An `onclick` event handler is then added to the `document` to hide the menu whenever a click occurs (which is the behavior of system context menus).

Though this example is very basic, it is the basis for all custom context menus on the Web. Applying some additional CSS to the context menu in this example can yield great results.

The beforeunload Event

The `beforeunload` event fires on the window and is intended to give developers a way to prevent the page from being unloaded. This event fires before the page starts to unload from the browser, allowing continued use of the page should it ultimately not be unloaded. You cannot cancel this event outright because that would be the equivalent of holding the user hostage on a page. Instead, the event gives you the ability to display a message to the user. The message indicates that the page is about to be unloaded, displays the message, and asks if the user would like to continue to close the page or remain on the page (see Figure 17-8).

In order to cause this dialog box to pop up, you must set `event.returnValue` equal to the string you want displayed in the dialog (for Internet Explorer and Firefox) and also return it as the function value (for Safari and Chrome), as in this example:

```
window.addEventListener("beforeunload", (event) => {
  let message = "I'm really going to miss you if you go.";
  event.returnValue = message;
  return message;
});
```

The DOMContentLoaded Event

The window's `load` event fires when everything on the page has been completely loaded, which may take some time for pages with lots of external resources. The `DOMContentLoaded` event fires as soon as the DOM tree is completely formed and without regard to images, JavaScript files, CSS files, or other such resources. As compared to the `load` event, `DOMContentLoaded` allows event handlers to be attached earlier in the page download process, which means a faster time to interactivity for users.

To handle the `DOMContentLoaded` event, you can attach an event handler either on the document or on the window (the target for the event actually is `document`, although it bubbles up to `window`). Here's an example which listens for the event on `document`:

```
document.addEventListener("DOMContentLoaded", (event) => {
  console.log("Content loaded");
});
```

The event object for `DOMContentLoaded` doesn't provide any additional information (target is `document`).

The `DOMContentLoaded` event is typically used to attach event handlers or perform other DOM manipulations. This event always fires before the `load` event.

For browsers that don't support `DOMContentLoaded`, it has been suggested that a timeout should be set during page loading with a millisecond delay of 0, as in this example:

```
setTimeout(() => {
  // attach event handlers here
}, 0);
```

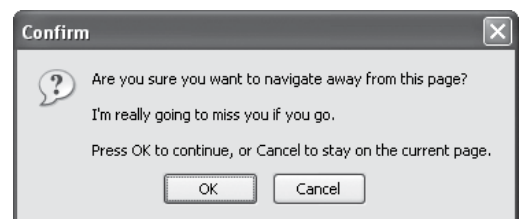

FIGURE 17-8:

This code essentially says, “Run this function as soon as the current JavaScript process is complete.” There is a single JavaScript process running as the page is being downloaded and constructed, so the timeout will fire after that. Whether or not this coincides directly with the timing of `DOMContentLoaded` relates to both the browser being used and other code on the page. To work properly, this must be the first timeout set on the page, and even then, it is not guaranteed that the timeout will run prior to the `load` event in all circumstances.

The `readystatechange` Event

Internet Explorer first defined an event called `readystatechange` on several parts of a DOM document. This somewhat mysterious event is intended to provide information about the loading state of the document or of an element, though its behavior is often erratic. Each object that supports the `readystatechange` event has a `readyState` property that can have one of the following five possible string values:

- `uninitialized`—The object exists but has not been initialized.
- `loading`—The object is loading data.
- `loaded`—The object has finished loading its data.
- `interactive`—The object can be interacted with but it’s not fully loaded.
- `complete`—The object is completely loaded.

Even though this seems straightforward, not all objects go through all `readyState` phases. The documentation indicates that objects may completely skip a phase if it doesn’t apply but doesn’t indicate which phases apply to which objects. This means that the `readystatechange` event often fires fewer than four times and the `readyState` value doesn’t always follow the same progression.

When used on `document`, a `readyState` of `"interactive"` fires the `readystatechange` event at a time similar to `DOMContentLoaded`. The `interactive` phase occurs when the entire DOM tree has been loaded and thus is safe to interact with. Images and other external resources may or may not be available at that point in time. The `readystatechange` event can be handled like this:

```
document.addEventListener("readystatechange", (event) => {
  if (document.readyState == "interactive") {
    console.log("Content loaded");
  }
});
```

The event object for this event doesn’t provide any additional information and has no target set.

When used in conjunction with the `load` event, the order in which these events fire is not guaranteed. In pages with numerous or large external resources, the `interactive` phase is reached well before the `load` event fires; in smaller pages with few or small external resources, the `readystatechange` event may not fire until after the `load` event.

To make matters even more confusing, the `interactive` phase may come either before or after the `complete` phase; the order is not constant. In pages with more external resources, it is more likely that the `interactive` phase will occur before the `complete` phase, whereas in pages with fewer resources, it is more likely that the `complete` phase will occur before the `interactive` phase. So, to ensure that you are

getting the earliest possible moment, it's necessary to check for both the interactive and the complete phases, as in this example:

```
document.addEventListener("readystatechange", (event) => {
  if (document.readyState == "interactive" ||
      document.readyState == "complete") {
    document.removeEventListener("readystatechange", arguments.callee);
    console.log("Content loaded");
  }
});
```

When the `readystatechange` event fires in this code, the `document.readyState` property is checked to see if it's either the interactive or the complete phase. If so, the event handler is removed to ensure that it won't be executed for another phase. Note that because the event handler is an anonymous function, `arguments.callee` is used as the pointer to the function. After that, the message is logged indicating that the content is loaded. This construct allows you to get as close as possible to the `DOMContentLoaded` event.

NOTE *Even though you can get close to mimicking `DOMContentLoaded` using `readystatechange`, they are not exactly the same. The order in which the `load` event and `readystatechange` events are fired is not consistent from page to page.*

The pageshow and pagehide Events

Firefox and Opera introduced a feature called the *back-forward cache* (*bfcache*), designed to speed up page transitions when using the browser's Back and Forward buttons. The cache stores not only page data but also the DOM and JavaScript state, effectively keeping the entire page in memory. If a page is in the *bfcache*, the `load` event will not fire when the page is navigated to. This usually doesn't cause an issue because the entire page state is stored. However, Firefox decided to provide some events to give visibility to the *bfcache* behavior.

The first event is `pageshow`, which fires whenever a page is displayed, whether from the *bfcache* or not. On a newly loaded page, `pageshow` fires after the `load` event; on a page in the *bfcache*, `pageshow` fires as soon as the page's state has been completely restored. Note that even though the target of this event is `document`, the event handler must be attached to `window`. Consider the following example which tracks these events:

```
(function() {
  let showCount = 0;

  window.addEventListener("load", () => {
    console.log("Load fired");
  });

  window.addEventListener("pageshow", () => {
    showCount++;
    console.log(`Show has been fired ${showCount} times.`);
  });
})();
```

This example uses a private scope to protect the `showCount` variable from being introduced into the global scope. When the page is first loaded, `showCount` has a value of 0. Every time the `pageshow` event fires, `showCount` is incremented and a message is logged. If you navigate away from the page containing this code and then click the Back button to restore it, you will see that the value of `showCount` is incremented each time. That's because the variable state, along with the entire page state, is stored in memory and then retrieved when you navigate back to the page. If you were to click the Reload button on the browser, the value of `showCount` would be reset to 0 because the page would be completely reloaded.

Besides the usual properties, the event object for `pageshow` includes a property called `persisted`. This is a Boolean value that is set to `true` if the page is stored in the `bfcache` or `false` if the page is not. The property can be checked in the event handler as follows:

```
(function() {
  let showCount = 0;

  window.addEventListener("load", () => {
    console.log("Load fired");
  });

  window.addEventListener("pageshow", () => {
    showCount++;
    console.log(`Show has been fired ${showCount} times.`,
      `Persisted? ${event.persisted}`);
  });
})();
```

The `persisted` property lets you determine if a different action must be taken depending on the state of the page in the `bfcache`.

The `pagehide` event is a companion to `pageshow` and fires whenever a page is unloaded from the browser, firing immediately before the `unload` event. As with the `pageshow` event, `pagehide` fires on the document even though the event handler must be attached to the `window`. The event object also includes the `persisted` property, though there is a slight difference in its usage. Consider the following example which checks the `event.persisted` property:

```
window.addEventListener("pagehide", (event) => {
  console.log("Hiding. Persisted? " + event.persisted);
});
```

You may decide to take a different action based on the value of `persisted` when `pagehide` fires. For the `pageshow` event, `persisted` is set to `true` if the page has been loaded from the `bfcache`; for the `pagehide` event, `persisted` is set to `true` if the page will be stored in the `bfcache` once unloaded. So the first time `pageshow` is fired, `persisted` is always `false`, whereas the first time `pagehide` is fired, `persisted` will be `true` (unless the page won't be stored in the `bfcache`).

NOTE Pages that have an `onunload` event handler assigned are automatically excluded from the `bfcache`, even if the event handler is empty. The reasoning is that `onunload` is typically used to undo what was done using `onload`, and so skipping `onload` the next time the page is displayed could cause it to break.

The hashchange Event

HTML5 introduced the `hashchange` event as a way to notify developers when the URL hash (everything following a pound sign (#) in a URL) changed. This came about as developers frequently used the URL hash to store state information or navigational information in Ajax applications.

The `onhashchange` event handler must be attached to the `window`, and it is called whenever the URL hash changes. The event object should have two additional properties: `oldURL` and `newURL`. These properties hold the complete URL including the hash before the change and after the change. The contrasting URLs are tracked in the following example:

```
window.addEventListener("hashchange", (event) => {
  console.log(`Old URL: ${event.oldURL}, New URL: ${event.newURL}`);
});
```

It's best to use the `location` object to determine the current hash:

```
window.addEventListener("hashchange", (event) => {
  console.log(`Current hash: ${location.hash}`);
});
```

Device Events

With the introduction of smartphones and tablet devices came a new set of ways for users to interact with a browser. As such, a new class of events was invented. *Device events* allow you to determine how a device is being used. A new draft for device events was started in 2011 at the W3C to cover the growing number of devices looking to implement device-related events.

The orientationchange Event

Apple created the `orientationchange` event on mobile Safari so that developers could determine when the user switched the device from landscape to portrait mode. There is a `window.orientation` property on mobile Safari that contains one of three values: 0 for portrait mode, 90 for landscape mode when rotated to the left (the Home button on the right), and -90 for landscape mode when rotated to the right (the Home button on the left). The documentation also mentions a value of 180 if the device is upside down, but that configuration is not supported to date. Figure 17-9 illustrates the various values for `window.orientation`.

Whenever the user changes from one mode to another, the `orientationchange` event fires. The event object doesn't contain any useful information because the only relevant information is accessible via `window.orientation`. Typical usage of this event is as follows:

```
window.addEventListener("load", (event) => {
  let div = document.getElementById("myDiv");
  div.innerHTML = "Current orientation is " + window.orientation;

  window.addEventListener("orientationchange", (event) => {}) {
    div.innerHTML = "Current orientation is " + window.orientation;
  });
});
```

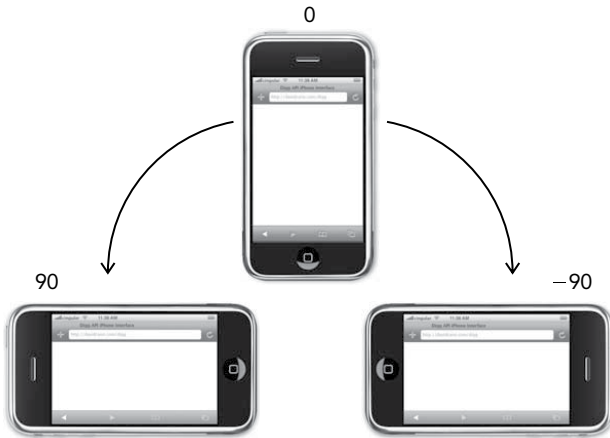



FIGURE 17-9:

In this example, the initial orientation is displayed when the `load` event fires. Then, the event handler for `orientationchange` is assigned. Whenever the event fires, the message on the page is updated to indicate the new orientation.

All iOS devices support both the `orientationchange` event and the `window.orientation` property.

NOTE *Because `orientationchange` is considered a window event, you can also assign an event handler by adding the `onorientationchange` attribute to the `<body>` element.*

The deviceorientation Event

The `deviceorientation` event is defined in the `DeviceOrientationEvent` specification. The event is fired on `window` when accelerometer information is available and changes. Keep in mind that the purpose of `deviceorientation` is to inform you of how the device is oriented in space and not of movement.

A device is said to exist in three-dimensional space along an `x`-axis, a `y`-axis, and a `z`-axis. These all start at zero when the device is at rest on a horizontal surface. The `x`-axis goes from the left of the device to the right, the `y`-axis goes from the bottom of the device to the top, and the `z`-axis goes from the back of the device to the front (see Figure 17-10).

When `deviceorientation` fires, it returns information about how the values of each axis have changed relative to the device at rest. The event object has five properties:



FIGURE 17-10:

- `alpha`—The difference in y-axis degrees as you rotate around the z-axis (side-to-side tilt); a floating point number between 0 and 360.
- `beta`—The difference in z-axis degrees as you rotate around the x-axis (front-to-back tilt); a floating point number between -180 and 180 .
- `gamma`—The difference in the z-axis degrees as you rotate around the y-axis (twisting tilt); a floating point number between -90 and 90 .
- `absolute`—A Boolean value indicating if the device is returning absolute values or not.
- `compassCalibrated`—A Boolean value indicating if the device's compass is properly calibrated or not.

Figure 17-11 shows how the values of `alpha`, `beta`, and `gamma` are calculated.

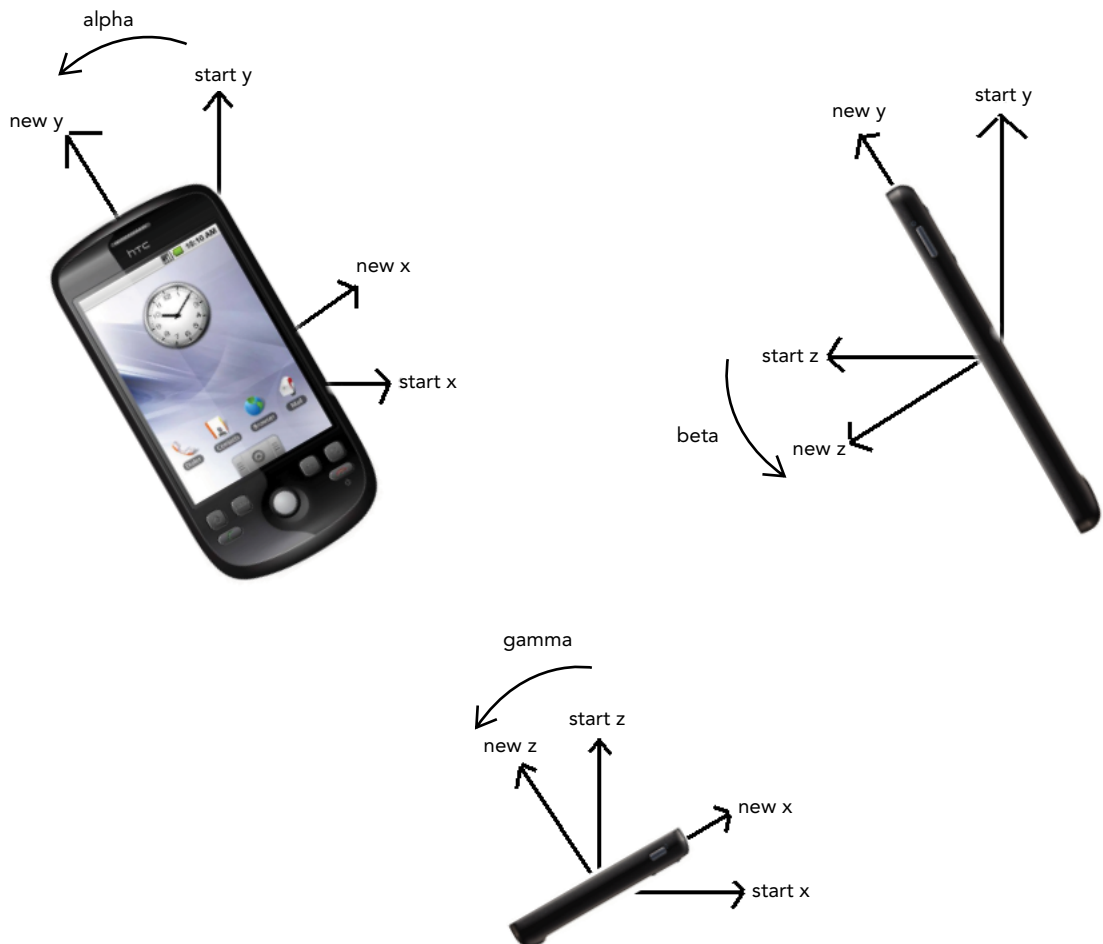

FIGURE 17-11:

Here's a simple example that outputs the values for alpha, beta, and gamma:

```

window.addEventListener("deviceorientation", (event) => {
  let output = document.getElementById("output");
  output.innerHTML =
    `Alpha=${event.alpha}, Beta=${event.beta}, Gamma=${event.gamma}<br>`;
});

```

You can use this information to rearrange or otherwise alter elements on the screen in reaction to the device changing its orientation. For example, this code rotates an element in reaction to the device orientation:

```

window.addEventListener("deviceorientation", (event) => {
  let arrow = document.getElementById("arrow");
  arrow.style.webkitTransform = `rotate(${Math.round(event.alpha)}deg)`;
});

```

This example works only on mobile WebKit browsers because of the use of the proprietary `webkitTransform` property (the temporary version of the CSS standard `transform` property). The element “arrow” is rotated along with the value of `event.alpha`, giving it a compass-like feel. The CSS3 rotation transformation is used with a rounded version of the value to ensure smoothness.

The devicemotion Event

The `DeviceOrientationEvent` specification also includes a `devicemotion` event. This event is designed to inform you when the device is actually moving, not just when it has changed orientation. For instance, `devicemotion` is useful to determine that the device is falling or is being held by someone who is walking.

When the `devicemotion` event fires, the `event` object contains the following additional properties:

- `acceleration`—An object containing `x`, `y`, and `z` properties that tells you the acceleration in each dimension without considering gravity.
- `accelerationIncludingGravity`—An object containing `x`, `y`, and `z` properties that tells you the acceleration in each dimension, including the natural acceleration of gravity in the `z`-axis.
- `interval`—The amount of time, in milliseconds, that will pass before another `devicemotion` event is fired. This value should be constant from event to event.
- `rotationRate`—An object containing the `alpha`, `beta`, and `gamma` properties that indicate device orientation.

If `acceleration`, `accelerationIncludingGravity`, or `rotationRate` cannot be provided, then the property value is `null`. Because of that, you should always check that the value is not `null` before using any of these properties. For example:

```

window.addEventListener("devicemotion", (event) => {
  let output = document.getElementById("output");
  if (event.rotationRate !== null) {
    output.innerHTML += `Alpha=${event.rotationRate.alpha}` +
      `Beta=${event.rotationRate.beta}` +
      `Gamma=${event.rotationRate.gamma}`;
  }
});

```

Touch and Gesture Events

Safari for iOS introduced several proprietary events designed to inform developers when specific events occur. Because iOS devices are mouseless and keyboardless, the regular mouse and keyboard events simply aren't enough to create a completely interactive web page designed with mobile Safari in mind. With the introduction of WebKit for Android, many of the proprietary events became de facto standards and led to the beginning of a Touch Events specification from the W3C. The following events work only on touch-based devices.

Touch Events

When the iPhone 3G was released with iOS 2.0 software, a new version of Safari was included. This new mobile Safari exposed several new events relating to touch interactions. The Android browser later implemented these same events. *Touch events* are fired when a finger is placed on the screen, dragged across the screen, or removed from the screen. The touch events are as follows:

- `touchstart`—Fires when a finger touches the screen even if another finger is already touching the screen.
- `touchmove`—Fires continuously as a finger is moved across the screen. Calling `preventDefault()` during this event prevents scrolling.
- `touchend`—Fires when a finger is removed from the screen.
- `touchcancel`—Fires when the system has stopped tracking the touch. It's unclear in the documentation as to when this can occur.

Each of these events bubbles and can be canceled. Even though touch events aren't part of the DOM specification, they are implemented in a DOM-compatible way. So the event object for each touch event provides properties that are common to mouse events: `bubbles`, `cancelable`, `view`, `clientX`, `clientY`, `screenX`, `screenY`, `detail`, `altKey`, `shiftKey`, `ctrlKey`, and `metaKey`.

In addition to these common DOM properties, touch events have the following three properties to track touches:

- `touches`—An array of `Touch` objects that indicate the currently tracked touches.
- `targetTouches`—An array of `Touch` objects specific to the event's target.
- `changedTouches`—An array of `Touch` objects that have been changed in the last user action.

Each `Touch` object, in turn, has the following properties:

- `clientX`—The x-coordinate of the touch target in the viewport.
- `clientY`—The y-coordinate of the touch target in the viewport.
- `identifier`—A unique ID for the touch.
- `pageX`—The x-coordinate of the touch target on the page.
- `pageY`—The y-coordinate of the touch target on the page.
- `screenX`—The x-coordinate of the touch target on the screen.

- `screenY`—The y-coordinate of the touch target on the screen.
- `target`—The DOM node target for the touch.

These properties can be used to track the touch around the screen. For example:

```
function handleTouchEvent(event) {
  // only for one touch
  if (event.touches.length == 1)
    let output = document.getElementById("output");
    switch(event.type) {
      case "touchstart":
        output.innerHTML += `<br>Touch started:` +
          ` (${event.touches[0].clientX}` +
          ` ${event.touches[0].clientY})`;

        break;
      case "touchend":
        output.innerHTML += `<br>Touch ended:` +
          ` (${event.changedTouches[0].clientX}` +
          ` ${event.changedTouches[0].clientY})`;

        break;
      case "touchmove":
        event.preventDefault(); // prevent scrolling
        output.innerHTML += `<br>Touch moved:` +
          ` (${event.changedTouches[0].clientX}` +
          ` ${event.changedTouches[0].clientY})`;

        break;
    }
  }
}

document.addEventListener("touchstart", handleTouchEvent);
document.addEventListener("touchend", handleTouchEvent);
document.addEventListener("touchmove", handleTouchEvent);
```

This code tracks a single touch around the screen. To keep things simple, it outputs information only when there's a single active touch. When the `touchstart` event occurs, it outputs the location of the touch into a `<div>`. When a `touchmove` event fires, its default behavior is canceled to prevent scrolling (moving touches typically scroll the page) and then it outputs information about the changed touch. The `touchend` event outputs the last information about the touch. Note that there is nothing in the `touches` collection during the `touchend` event, because there is no longer an active touch; the `changedTouches` collection must be used instead.

These events fire on all elements of the document, so you can manipulate different parts of the page individually. The order of events (including mouse events) when you tap on an element are:

1. `touchstart`
2. `mouseover`
3. `mousemove (once)`
4. `mousedown`
5. `mouseup`

6. `click`
7. `touchend`

Gesture Events

The iOS 2.0 version of Safari also introduced a class of events for gestures. A *gesture* occurs when two fingers are touching the screen and typically causes a change in the scale of the displayed item or the rotation. There are three gesture events, as described here:

- `gesturestart`—Fires when a finger is already on the screen and another finger is placed on the screen.
- `gesturechange`—Fires when the position of either finger on the screen has changed.
- `gestureend`—Fires when one of the fingers has been removed from the screen.

These events fire only if the two fingers are touching the recipient of the event. Setting event handlers on a single element means that both fingers must be within the bounds of the element in order for gesture events to fire (this will be the target). Because these events bubble, you can also place event handlers at the document level to handle all gesture events. When you are using this approach, the target of the event will be the element that has both fingers within its boundaries.

There is a relationship between the touch and the gesture events. When a finger is placed on the screen, the `touchstart` event fires. When another finger is placed on the screen, the `gesturestart` event fires first and is followed by the `touchstart` event for that finger. If one or both of the fingers are moved, a `gesturechange` event is fired. As soon as one of the fingers is removed, the `gestureend` event fires, followed by `touchend` for that finger.

As with touch events, each gesture event object contains all of the standard mouse event properties: `bubbles`, `cancelable`, `view`, `clientX`, `clientY`, `screenX`, `screenY`, `detail`, `altKey`, `shiftKey`, `ctrlKey`, and `metaKey`. The two additions to the event object are `rotation` and `scale`. The `rotation` property indicates the degrees of rotation that the fingers have changed, where negative numbers indicate a counterclockwise rotation and positive numbers indicate clockwise rotation (the value begins as 0). The `scale` property indicates how much of a change in distance occurred between the fingers (making a pinch motion). This starts out as 1 and will either increase as the distance increases or decrease as the distance decreases.

These events can be used as follows:

```
function handleGestureEvent(event) {
  let output = document.getElementById("output");
  switch(event.type) {
    case "gesturestart":
      output.innerHTML += `Gesture started: ` +
        `rotation=${event.rotation}, ` +
        `scale=${event.scale}`;
      break;
    case "gestureend":
      output.innerHTML += `Gesture ended: ` +
        `rotation=${event.rotation}, ` +
        `scale=${event.scale}`;
      break;
  }
}
```

```

    case "gesturechange":
        output.innerHTML += `Gesture changed: ` +
            `rotation=${event.rotation}, ` +
            `scale=${event.scale}`;
        break;
    }
}

document.addEventListener("gesturestart", handleGestureEvent, false);
document.addEventListener("gestureend", handleGestureEvent, false);
document.addEventListener("gesturechange", handleGestureEvent, false);

```

As with the touch events example, this code simply wires up each event to a single function and then outputs information about each event.

NOTE *Touch events also return **rotation** and **scale** properties, but they change only when two fingers are in contact with the screen. Generally, it is easier to use gesture events with two fingers than to manage all interactions with touch events.*

Event Reference

The following is a list of all available browser events defined in a DOM specification, the HTML5 specification, and any other currently published specifications which outline event behavior. They are categorized by API and/or the specification in which they appear.

NOTE *This list excludes some categories that contain only vendor-specific events.*

Ambient Light events

devicelight

App Cache events

cached
checking
downloading
noupdate
obsolete
updateready

Audio Channels API events

headphoneschange
mozinterruptbegin
mozinterruptend

Battery API events

chargingchange
chargingtimechange

dischargingtimechange
levelchange

Broadcast Channel API events

message

Channel Messaging API events

message

Clipboard API events

beforecopy
beforecut
beforepaste
copy
cut
paste

Contacts API events

contactchange

error
success

CSS Font Loading**API events**

loading
loadingdone
loadingerror

CSSOM events

animationend
animationiteration
animationstart
transitionend

CSSOM View events

resize
scroll

Device Orientation events

compassneeds calibration
devicemotion
deviceorientation

Device Storage API events

change

DOM events

abort
beforeinput
blur
click
compositionend
compositionstart
compositionupdate
dblclick
error
focus
focusin
focusout
input
keydown
keypress
keyup
load
mousedown
mouseenter
mouseleave
mousemove
mouseout
mouseover
mouseup
resize
scroll
select

unload
wheel

Download API events

statechange

Encrypted Media Extensions events

encrypted
keystatuschange
message
waitingforkey

Engineering Mode API events

message

File API events

abort
error
load
loadend
loadstart
progress

File System API events

error
writeend

FMRadio API events

antennaavailablechange
disabled
enabled
frequencychange

Fullscreen API events

fullscreenchange
fullscreenerror

Gamepad API events

gamepadconnected
gamepaddisconnected

HTML DOM events

DOMContentLoaded
abort
afterprint
afterscriptexecute
beforeprint
beforescriptexecute
beforeunload
blur
cancel
canplay
canplaythrough
change

click
close
connect
contextmenu
durationchange
emptied
error
focus
hashchange
input
invalid
languagechange
load
loadeddata
loadedmetadata
loadend
loadstart
message
offline
online
open
pagehide
pageshow
play
playing
popstate
progress
readystatechange
rejectionhandled
reset
seeked
seeking
select
show
sort
stalled
storage
submit
suspend
timeupdate
toggle
unhandledrejection
unload
volumechange
waiting

HTML Drag and Drop API**events**

drag
dragend
dragenter
dragexit
dragleave
dragover
dragstart
drop

IndexedDB events

abort
blocked
close
complete
error
success
upgradeneeded
versionchange

Inter-App Connection API events

message

Media Capture and Streams events

active
addtrack
devicechange
ended
inactive
mute
overconstrained
ratechange
removetrack
started
unmute

Media Source Extensions events

abort
addsourcebuffer
error
removesourcebuffer
sourceclose
sourceended
sourceopen
update
updateend
updatestart

MediaStream Recording events

dataavailable
error
pause
resume
start
stop

Mobile Connection API events

cardstatechange
icccardlockerror

Mobile Messaging API events

close
deliveryerror
deliverysuccess
error

failed
message
open
received
retrieving
sending
sent

Network Information API events
change

Page Visibility API events
visibilitychange

Payment Request API events
shippingaddresschange
shippingoptionchange

Performance API events
resourcetimingbufferfull

Pointer events
gotpointercapture
lostpointercapture
pointercancel
pointerdown
pointerenter
pointerleave
pointermove
pointerout
pointerover
pointerup

Pointer Lock API events
pointerlockchange
pointerlockerror

Presentation API events
change
sessionavailable
sessionconnect

Proximity events
deviceproximity
userproximity

Push API events
push
pushsubscriptionchange

Screen Orientation API events
change

Selection API events
selectionchange
selectstart

Server Sent events
error
message
open

Service Workers API events
activate
controllerchange
error
fetch
install
message
statechange
updatefound

Settings API events
settingchange

Simple Push API events
error
success

Speaker Manager API events
speakerforcedchange

SVG events
DOMAttrModified
DOMCharacterDataModified
DOMNodeInserted
DOMNodeInsertedIntoDocument
DOMNodeRemoved
DOMNodeRemovedFromDocument
DOMSubtreeModified
SVGAbort
SVGError
SVGLoad
SVGResize
SVGScroll
SVGUnload
SVGZoom
activate
beginEvent
click
endEvent
focusin
focusout
mousedown
mousemove
mouseout
mouseover
mouseup
repeatEvent

TCP Socket API events
connect
data

drain
error

Time and Clock API**events**

moztimechange

Touch events

touchcancel
touchend
touchmove
touchstart

TV API events

currentchannelchanged
currentsourcechanged
eitbroadcasted
scanningstatechanged

UDP Socket API events

message

Web Audio API events

audioprocess
complete
ended
loaded
message
nodecreate
statechange

Web Components events

slotchange

WebGL events

webglcontextcreationerror
webglcontextlost
webglcontextrestored

Web Manifest events

install

Web MIDI API events

midimessage
statechange

Web Notifications events

click
close
error
show

WebRTC events

addstream
close

datachannel
error
icecandidate
iceconnectionstatechange
icegatheringstatechange
identityresult
idpassertionerror
idpvalidationerror
isolationchange
message
negotiationneeded
open
peeridentity
removestream
signalingstatechange
tonechange

Websockets API events

close
error
message
open

Web Speech API events

audioend
audiostart
boundary
end_(SpeechRecognition)
end_(SpeechSynthesis)
error_(SpeechRecognitionError)
error_(SpeechSynthesis)
mark
nomatch
pause_(SpeechSynthesis)
result
resume
soundend
soundstart
speechend
speechstart
start_(SpeechRecognition)
start_(SpeechSynthesis)

Web Storage API events

storage

Web Telephony API events

incoming

WebVR API events

vrdisplayactivate
vrdisplayblur
vrdisplayconnected
vrdisplaydeactivate
vrdisplaydisconnected

```
vrdisplayfocus
vrdisplaypresentchange
```

WebVTT events

```
addtrack
change
cuechange
enter
exit
removetrack
```

WiFi Information API events

```
connectioninfoupdate
statuschange
```

WiFi P2P API events

```
disabled
enabled
peerinfoupdate
statuschange
```

XMLHttpRequest events

```
abort
error
load
loadend
loadstart
progress
readystatechange
timeout
```

MEMORY AND PERFORMANCE

Because event handlers provide the interaction on modern web applications, many developers mistakenly add a large number of them to the page. In languages that create GUIs, such as C#, it's customary to add an `onclick` event handler to each button in the GUI, and there is no real penalty for doing so. In JavaScript, the number of event handlers on the page directly relates to the overall performance of the page. This happens for a number of reasons. The first is that each function is an object and takes up memory; the more objects in memory, the slower the performance. Second, the amount of DOM access needed to assign all of the event handlers up front delays the interactivity of the entire page. There are a number of ways that you can improve performance by minding your use of event handlers.

Event Delegation

The solution to the “too many event handlers” issue is called *event delegation*. Event delegation takes advantage of event bubbling to assign a single event handler to manage all events of a particular type. The `click` event, for example, bubbles all the way up to the `document` level. This means that it's possible to assign one `onclick` event handler for an entire page instead of one for each clickable element. Consider the following HTML:

```
<ul id="myLinks">
  <li id="goSomewhere">Go somewhere</li>
  <li id="doSomething">Do something</li>
  <li id="sayHi">Say hi</li>
</ul>
```

The HTML in this example contains three items that should perform actions when clicked. Traditional thinking simply attaches three event handlers like this:

```
let item1 = document.getElementById("goSomewhere");
let item2 = document.getElementById("doSomething");
let item3 = document.getElementById("sayHi");
```

```
item1.addEventListener("click", (event) => {
  location.href = "http:// www.wrox.com";
});

item2.addEventListener("click", (event) => {
  document.title = "I changed the document's title";
});

item3.addEventListener("click", (event) => {
  console.log("hi");
});
```

If this scenario is repeated for all of the clickable elements in a complex web application, the result is an incredibly long section of code that simply attaches event handlers. Event delegation approaches this problem by attaching a single event handler to the highest possible point in the DOM tree, as in this example:

```
let list = document.getElementById("myLinks");

list.addEventListener("click", (event) => {
  let target = event.target;

  switch(target.id) {
    case "doSomething":
      document.title = "I changed the document's title";
      break;

    case "goSomewhere":
      location.href = "http:// www.wrox.com";
      break;

    case "sayHi":
      console.log("hi");
      break;
  }
});
```

In this code, event delegation is used to attach a single `onclick` event handler to the `` element. Because all of the list items are children of this element, their events bubble up and are handled by this function. The event target is the list item that was clicked so you can check the `id` property to determine the appropriate action. In comparison with the previous code that didn't use event delegation, this code has less of an up-front cost because it just retrieves one DOM element and attaches one event handler. The end result is the same for the user, but this approach requires much less memory. All events that use buttons (most mouse events and keyboard events) are candidates for this technique.

If it's practical, you may want to consider attaching a single event handler on `document` that can handle all of the page events of a particular type. This has the following advantages compared to traditional techniques:

- The `document` object is immediately available and can have event handlers assigned at any point during the page's life cycle (no need to wait for `DOMContentLoaded` or `load` events). This means that as soon as a clickable element is rendered, it can function appropriately without delay.

- Less time is spent setting up event handlers on the page. Assigning one event handler takes fewer DOM references and less time.
- Lower memory usage is required for the entire page, improving overall performance.

The best candidates for event delegation are `click`, `mousedown`, `mouseup`, `keydown`, `keyup`, and `keypress`. The `mouseover` and `mouseout` events bubble but are complicated to handle properly and often require calculating element position to appropriately handle (because `mouseout` fires when moving from an element to one of its child nodes and when moving outside of the element).

Removing Event Handlers

When event handlers are assigned to elements, a connection is formed between code that is running the browser and JavaScript code interacting with the page. The more of these connections that exist, the slower a page performs. One way to handle this issue is through event delegation to limit the number of connections that are set up. Another way to manage the issue is to remove event handlers when they are no longer needed. Dangling event handlers, those that remain in memory after they are necessary, are a major source of memory and performance issues in web applications.

This problem occurs at two specific points during a page's life cycle. The first is when an element is removed from the document while it has event handlers attached. This can be due to a true DOM manipulation involving `removeChild()` or `replaceChild()`, but it happens most often when using `innerHTML` to replace a section of the page. Any event handlers assigned to an element that was eliminated by the call to `innerHTML` may not be properly garbage collected. Consider the following example:

```
<div id="myDiv">
  <input type="button" value="Click Me" id="myBtn">
</div>
<script type="text/javascript">
  let btn = document.getElementById("myBtn");
  btn.onclick = function() {

    // do something

    document.getElementById("myDiv").innerHTML = "Processing...";
    // Bad!!!
  };
</script>
```

Here, a button exists inside of a `<div>` element. When the button is clicked, it is removed and replaced with a message to prevent double-clicking, which is a very common paradigm on websites. The issue is that the button still had an event handler attached when it was removed from the page. Setting `innerHTML` on the `<div>` removed the button completely, but the event handler remains attached. Some browsers, especially Internet Explorer 8 and earlier, will have trouble in this situation, and most likely, references to both the element and the event handler will remain in memory. If you know that a given element is going to be removed, it's best to manually remove the event handlers yourself, as in this example:

```
<div id="myDiv">
  <input type="button" value="Click Me" id="myBtn">
</div>
```

```
<script type="text/javascript">
  let btn = document.getElementById("myBtn");
  btn.onclick = function() {

    // do something

    btn.onclick = null;    // remove event handler

    document.getElementById("myDiv").innerHTML = "Processing...";
  };
</script>
```

In this rewritten code, the button's event handler is removed before setting the `<div>` element's `innerHTML`. This ensures that the memory will be reclaimed and the button can safely be removed from the DOM.

Note also that removing the button in the event handler prevents bubbling of the event. An event will bubble only if its target is still present in the document.

NOTE *Event delegation also helps solve this problem. If you know that a particular part of the page is going to be replaced using `innerHTML`, do not attach event handlers directly to elements within that part. Instead, attach event handlers at a higher level that can handle events in that area.*

The other time that dangling event handlers are a problem is when the page is unloaded. Once again, Internet Explorer 8 and earlier have a lot of problems with this situation, though it seems to affect all browsers in some way. If event handlers aren't cleaned up before the page is unloaded, they remain in memory. Each time the browser loads and unloads the page after that (as a result of navigating away and back or clicking the Reload button), the number of objects in memory increases because the event handler memory is not being reclaimed.

Generally speaking, it's a good idea to remove all event handlers before the page is unloaded by using an `onunload` event handler. This is another area where event delegation helps because it is easier to keep track of the event handlers to remove when there are fewer of them. A good way to think about this technique is that anything done using an `onload` event handler must be reversed using `onunload`.

NOTE *Keep in mind that assigning an `onunload` event handler means that your page will not be stored in the `bfcache`. If this is of concern, you may want to use `onunload` to remove event handlers only in Internet Explorer.*

SIMULATING EVENTS

Events are designed to indicate particular moments of interest in a web page. These events are often fired based on user interaction or other browser functionality. It's a little-known fact that JavaScript can be used to fire specific events at any time, and those events are treated the same as events that

are created by the browser. This means that the events bubble appropriately and cause the browser to execute event handlers assigned to deal with the event. This capability can be extremely useful in testing web applications. The DOM Level 3 specification indicates ways to simulate specific types of events. Internet Explorer 8 and earlier versions have their own way to simulate events.

DOM Event Simulation

An event object can be created at any time by using the `createEvent()` method on `document`. This method accepts a single argument, which is a string indicating the type of event to create. In DOM Level 2, all of these strings were plural, while DOM Level 3 changed them to singular. The string may be one of the following:

- `UIEvents`—Generic UI event. Mouse events and keyboard events inherit from UI events. For DOM Level 3, use `UIEvent`.
- `MouseEvent`—Generic mouse event. For DOM Level 3, use `MouseEvent`.
- `HTMLEvents`—Generic HTML event. There is no equivalent DOM Level 3 Event. (HTML events were dispersed into other groupings.)

Note that keyboard events are not specifically described in DOM Level 2 Events and were only later introduced in DOM Level 3 Events.

Once an event object is created, it needs to be initialized with information about the event. Each type of event object has a specific method that is used to initialize it with the appropriate data. The name of the method is different, depending on the argument that was used with `createEvent()`.

The final step in event simulation is to fire the event. This is done by using the `dispatchEvent()` method that is present on all DOM nodes that support events. The `dispatchEvent()` method accepts a single argument, which is the event object representing the event to fire. After that point, the event becomes “official,” bubbling and causing event handlers to execute.

Simulating Mouse Events

Mouse events can be simulated by creating a new mouse event object and assigning the necessary information. A mouse event object is created by passing "MouseEvent" into the `createEvent()` method. The returned object has a method called `initMouseEvent()` that is used to assign mouse-related information. This method accepts 15 arguments, one for each property typically available on a mouse event. The arguments are as follows:

- `type` (string)—The type of event to fire, such as "click".
- `bubbles` (Boolean)—Indicates if the event should bubble. This should be set to `true` for accurate mouse event simulation.
- `cancelable` (Boolean)—Indicates if the event can be canceled. This should be set to `true` for accurate mouse event simulation.
- `view` (AbstractView)—The view associated with the event. This is almost always `document.defaultView`.

- `detail` (integer)—Additional information for the event. This is used only by event handlers, though it's typically set to 0.
- `screenX` (integer)—The x-coordinate of the event relative to the screen.
- `screenY` (integer)—The y-coordinate of the event relative to the screen.
- `clientX` (integer)—The x-coordinate of the event relative to the viewport.
- `clientY` (integer)—The y-coordinate of the event relative to the viewport.
- `ctrlKey` (Boolean)—Indicates if the Ctrl key is pressed. The default is `false`.
- `altKey` (Boolean)—Indicates if the Alt key is pressed. The default is `false`.
- `shiftKey` (Boolean)—Indicates if the Shift key is pressed. The default is `false`.
- `metaKey` (Boolean)—Indicates if the Meta key is pressed. The default is `false`.
- `button` (integer)—Indicates the button that was pressed. The default is 0.
- `relatedTarget` (object)—An object related to the event. This is used only when simulating `mouseover` or `mouseout`.

As should be obvious, the arguments for `initMouseEvent()` map directly to the event object properties for a mouse event. The first four arguments are the only ones that are critical for the proper execution of the event because they are used by the browser; only event handlers use the other arguments. The `target` property of the event object is set automatically when it is passed into the `dispatchEvent()` method. As an example, the following simulates a click on a button using default values:

```
let btn = document.getElementById("myBtn");

// create event object
let event = document.createEvent("MouseEvent");

// initialize the event object
event.initMouseEvent("click", true, true, document.defaultView,
                    0, 0, 0, 0, 0, false, false, false, false, 0, null);

// fire the event
btn.dispatchEvent(event);
```

All other mouse events, including `dblclick`, can be simulated using this same technique in DOM-compliant browsers.

Simulating Keyboard Events

As mentioned previously, keyboard events were left out of DOM Level 2 Events, so simulating keyboard events is not straightforward. Keyboard events were included in draft versions of DOM Level 2 Events and were removed before finalization. It's worth noting that keyboard events in DOM Level 3 are drastically different from the draft version originally included in DOM Level 2.

The DOM Level 3 way to create a keyboard event is to pass "KeyboardEvent" into the `createEvent()` method. Doing so creates an event object with a method called `initKeyboardEvent()`. This method has the following parameters:

- `type` (string)—The type of event to fire, such as "keydown".
- `bubbles` (Boolean)—Indicates if the event should bubble. This should be set to `true` for accurate mouse event simulation.
- `cancelable` (Boolean)—Indicates if the event can be canceled. This should be set to `true` for accurate mouse event simulation.
- `view` (AbstractView)—The view associated with the event. This is almost always `document.defaultView`.
- `key` (string)—String code for the key that was pressed.
- `location` (integer)—The location of the key that was pressed. 0 for default keyboard, 1 for the left location, 2 for the right location, 3 for the numeric keypad, 4 for mobile (indicating a virtual keypad), or 5 for joystick.
- `modifiers` (string)—A space-separated list of modifiers such as "Shift".
- `repeat` (integer)—The number of times this key has been pressed in a row.

Keep in mind that DOM Level 3 Events deprecate the `keypress` event, so you can simulate only the `keydown` and `keyup` events using this technique:

```
let textbox = document.getElementById("myTextbox"),
    event;

// create event object the DOM Level 3 way
if (document.implementation.hasFeature("KeyboardEvents", "3.0")) {
    event = document.createEvent("KeyboardEvent");

    // initialize the event object
    event.initKeyboardEvent("keydown", true, true, document.defaultView, "a",
        0, "Shift", 0);
}
// fire the event
textbox.dispatchEvent(event);
```

This example simulates `keydown` of the A key while Shift is being held. You should always check for DOM Level 3 keyboard events support before attempting to use `document.createEvent("KeyboardEvent")`; other browsers return a nonstandard `KeyboardEvent` object.

Firefox allows you to create a keyboard event by passing "KeyEvents" into the `createEvent()` method. This returns an event object with a method called `initKeyEvent()`, which accepts the following 10 arguments:

- `type` (string)—The type of event to fire, such as "keydown".
- `bubbles` (Boolean)—Indicates if the event should bubble. This should be set to `true` for accurate mouse event simulation.

- `cancelable` (Boolean)—Indicates if the event can be canceled. This should be set to `true` for accurate mouse event simulation.
- `view` (`AbstractView`)—The view associated with the event. This is almost always `document.defaultView`.
- `ctrlKey` (Boolean)—Indicates if the Ctrl key is pressed. The default is `false`.
- `altKey` (Boolean)—Indicates if the Alt key is pressed. The default is `false`.
- `shiftKey` (Boolean)—Indicates if the Shift key is pressed. The default is `false`.
- `metaKey` (Boolean)—Indicates if the Meta key is pressed. The default is `false`.
- `keyCode` (integer)—The key code of the key that was pressed or released. This is used for `keydown` and `keyup`. The default is 0.
- `charCode` (integer)—The ASCII code of the character generated from the key press. This is used for `keypress`. The default is 0.

A keyboard event can then be fired by passing this event object to `dispatchEvent()`, as in this example:

```
// for Firefox only
let textbox = document.getElementById("myTextbox");

// create event object
let event = document.createEvent("KeyEvents");

// initialize the event object
event.initKeyEvent("keydown", true, true, document.defaultView, false,
                  false, true, false, 65, 65);

// fire the event
textbox.dispatchEvent(event);
```

This example simulates `keydown` for the A key with the Shift key held down. You can also simulate `keyup` and `keypress` events using this technique.

For other browsers, you'll need to create a generic event and assign keyboard-specific information to it, as shown in this example:

```
let textbox = document.getElementById("myTextbox");

// create event object
let event = document.createEvent("Events");

// initialize the event object
event.initEvent(type, bubbles, cancelable);
event.view = document.defaultView;
event.altKey = false;
event.ctrlKey = false;
event.shiftKey = false;
event.metaKey = false;
event.keyCode = 65;
event.charCode = 65;
```

```
// fire the event
textbox.dispatchEvent(event);
```

This code creates a generic event, initializes it by using `initEvent()`, and then assigns keyboard event information. It's necessary to use a generic event instead of a UI event because the UI event prevents new properties from being added to the event object (except in Safari). Simulating an event in this way causes the keyboard event to fire, but no text will be placed into the text box because this doesn't accurately simulate a keyboard event.

Simulating Other Events

Mouse events and keyboard events are the ones most often simulated in the browser, though it is possible to simulate HTML events as well. HTML events are simulated by creating an event object, using `createEvent("HTMLEvents")`, and then initializing the event object using `initEvent()` as shown in this example:

```
let event = document.createEvent("HTMLEvents");
event.initEvent("focus", true, false);
target.dispatchEvent(event);
```

This example fires the `focus` event on a given target. Other HTML events may be simulated the same way.

NOTE *HTML events are rarely used in browsers because they are of limited utility.*

Custom DOM Events

DOM Level 3 specifies a class of events called *custom events*. Custom events don't get fired natively by the DOM but are provided so that developers can create their own events. You create a new custom event by calling `createEvent("CustomEvent")`. The returned object has a method called `initCustomEvent()`, which takes four arguments:

- `type` (string)—The type of event to fire, such as "keydown".
- `bubbles` (Boolean)—Indicates if the event should bubble.
- `cancelable` (Boolean)—Indicates if the event can be canceled.
- `detail` (object)—Any value. This fills in the `detail` property of the event object.

The created event can then be dispatched in the DOM just like any other event, shown here:

```
let div = document.getElementById("myDiv"),
    event;

div.addEventListener("myevent", (event) => {
  console.log("DIV: " + event.detail);
});
```

```

document.addEventListener("myevent", (event) => {
  console.log("DOCUMENT: " + event.detail);
});

if (document.implementation.hasFeature("CustomEvents", "3.0")) {
  event = document.createEvent("CustomEvent");
  event.initCustomEvent("myevent", true, false, "Hello world!");
  div.dispatchEvent(event);
}

```

This example creates a bubbling event called "myevent". The value of `event.detail` is set to a simple string and is then listened for both on a `<div>` element and at the `document` level. Because the event is specified as bubbling using `initCustomEvent()`, the browser takes care of bubbling the event up to the `document`.

Internet Explorer Event Simulation

Event simulation in Internet Explorer 8 and earlier follows a similar pattern as event simulation in the DOM: You create an event object, assign the appropriate information, and then fire the event using the object. Of course, Internet Explorer has different ways of doing each step.

The `createEventObject()` method of `document` creates an event object. Unlike the DOM, this method accepts no arguments and returns a generic event object. After that, you must manually assign all of the properties that you want to have on the object. (There is no method to do this.) The last step is to call `fireEvent()` on the target, which accepts two arguments: the name of the event handler and the event object. When `fireEvent()` is called, the `srcElement` and `type` properties are automatically assigned to the event object; all other properties must be manually assigned. This means that all events that Internet Explorer supports are simulated using the same algorithm. For example, the following fires a `click` event on a button:

```

var btn = document.getElementById("myBtn");

// create event object
var event = document.createEventObject();

// initialize the event object
event.screenX = 100;
event.screenY = 0;
event.clientX = 0;
event.clientY = 0;
event.ctrlKey = false;
event.altKey = false;
event.shiftKey = false;
event.button = 0;

// fire the event
btn.fireEvent("onclick", event);

```

This example creates an event object and then initializes it with some information. Note that property assignment is free-form, so you can assign any properties you'd like, including those not normally supported by Internet Explorer 8 and earlier. The property values are of no consequence to the event, because only event handlers use them.

The same algorithm can be used to fire a `keypress` event as well, as shown in this example:

```
var textbox = document.getElementById("myTextbox");

// create event object
var event = document.createEventObject();

// initialize the event object
event.altKey = false;
event.ctrlKey = false;
event.shiftKey = false;
event.keyCode = 65;

// fire the event
textbox.fireEvent("onkeypress", event);
```

Because there is no difference between `event` objects for mouse, keyboard, or other events, a generic event object can be used to fire any type of event. Note that, as with DOM keyboard event simulation, no characters will appear in a text box as the result of a simulated `keypress` event even though the event handler will fire.

SUMMARY

Events are the primary way that JavaScript is tied to web pages. Most common events are defined in the DOM Level 3 Events specification or in HTML5. Even though there is a specification for basic events, many browsers have gone beyond the specification and implemented proprietary events to give developers greater insight into user interactions. Some proprietary events are directly related to specific devices.

There are some memory and performance considerations surrounding events. For example:

- It's best to limit the number of event handlers on a page because they can take up more memory and make the page feel less responsive to the user.
- Event delegation can be used to limit the number of event handlers by taking advantage of event bubbling.
- It's a good idea to remove all event handlers that were added before the page is unloaded.

It's possible to simulate events in the browser using JavaScript. The DOM Level 2 and 3 Events specifications provide for the simulation of all events, making it easy to simulate all defined events. It's also possible to simulate keyboard events to a point by using a combination of other techniques. Internet Explorer 8 and earlier also support event simulation, albeit through a different interface.

Events are one of the most important topics in JavaScript, and a good understanding of how they work and their performance implications is critical.

18

Animation and Graphics with Canvas

WHAT'S IN THIS CHAPTER?

- Using `requestAnimationFrame`
- Understanding the `<canvas>` element
- Drawing simple 2D graphics
- 3D drawing with WebGL

Graphics and animation in the browser are an increasingly essential component of the modern web, but they are also extremely difficult to do well. Visually complicated features require performance tuning and hardware acceleration so that they don't slow down the browser. An increasingly robust suite of APIs and tools allows for development of such features.

Arguably, HTML5's most popular addition is the `<canvas>` element. This element designates an area of the page where graphics can be created, on the fly, using JavaScript. Originally proposed by Apple for use with its Dashboard widgets, `<canvas>` quickly was added into HTML5 and found a very fast adoption rate by browsers. All major browsers support `<canvas>` to some degree.

Similar to the other parts of the browser environment, `<canvas>` is made up of a few API sets, and not all browsers support all API sets. There is a 2D context with basic drawing capabilities and a proposed 3D context called WebGL. The latest versions of the supporting browsers now support both the 2D context and WebGL.

USING `requestAnimationFrame`

For a long time, timers and intervals have been the state of the art for JavaScript-based animations. While CSS transitions and animations make some animations easy for web developers, little has changed in the world of JavaScript-based animation over the years. Firefox 4 was the first browser to include a new API for JavaScript animations called `mozRequestAnimationFrame()`. This method indicates to the browser that an animation is taking place so that the browser can, in turn, determine the best way to schedule a redraw. Since its introduction, the API gained widespread adoption and is now available across all major browsers as `requestAnimationFrame()`.

Early Animation Loops

The typical way to create animations in JavaScript is to use `setInterval()` to manage all animations. A basic animation loop using `setInterval()` looks like this:

```
(function() {  
  function updateAnimations() {  
    doAnimation1();  
    doAnimation2();  
    //etc.  
  }  
  setInterval(updateAnimations, 100);  
})();
```

To build out a small animation library, the `updateAnimations()` method would cycle through the running animations and make the appropriate changes to each one (for example, both a news ticker and a progress bar running together). If there are no animations to update, the method can exit without doing anything and perhaps even stop the animation loop until more animations are ready for updating.

The tricky part about this animation loop is knowing what the delay should be. The interval has to be short enough to handle a variety of different animation types smoothly but long enough so as to produce changes the browser can actually render. Most computer monitors refresh at a rate of 60 Hz, which basically means there's a repaint 60 times per second. Most browsers cap their repaints so they do not attempt to repaint any more frequently than that, knowing that the end user gets no improvement in experience.

Therefore, the best interval for the smoothest animation is $1000\text{ms}/60$, or about 17ms. You'll see the smoothest animation at this rate because you're more closely mirroring what the browser is capable of doing. Multiple animations may need to be throttled so they don't complete too quickly when using an animation loop with a 17ms interval.

Even though `setInterval()`-based animation loops are more efficient than having multiple sets of `setTimeout()`-based loops, there are still problems. Neither `setInterval()` nor `setTimeout()` are intended to be precise. The delay you specify as the second argument is only an indication of when the code is added in the browser's UI thread queue for possible execution. If there are other jobs in the queue ahead of it, then that code waits to be executed. In short, the millisecond delay is not an indication of when the code will be executed, only an indication of when the job will be queued. If the UI thread is busy, perhaps dealing with user actions, then that code will not execute immediately.

Problems with Intervals

Understanding when the next frame will be drawn is key to smooth animations, and until recently, there was no way to guarantee when the next frame would be drawn in a browser. As `<canvas>` became popular and new browser-based games emerged, developers became increasingly frustrated with the inaccuracy of `setInterval()` and `setTimeout()`.

Exacerbating these problems is the timer resolution of the browser. Timers are not accurate to the millisecond. Here are some common timer resolutions:

- Internet Explorer 8 and earlier have a timer resolution of 15.625ms.
- Internet Explorer 9 and later have a timer resolution of 4ms.
- Firefox and Safari have a timer resolution of ~10ms.
- Chrome has a timer resolution of 4ms.

Internet Explorer prior to version 9 has a timer resolution of 15.625ms, so any value between 0 and 15 could be either 0 or 15 but nothing else. Internet Explorer 9 improved timer resolution to 4ms, but that's still not very specific when it comes to animations. Chrome's timer resolution is 4ms, while Firefox's and Safari's is 10ms. Complicating matters more is that browsers have started to throttle timers for tabs that are in the background or inactive. So even if you set your interval for optimum display, you're still only getting close to the timing you want.

requestAnimationFrame

Robert O'Callahan of Mozilla was thinking about this problem and came up with a unique solution. He pointed out that CSS transitions and animations benefit from the browser knowing that some animation should be happening, and so figured out the correct interval at which to refresh the UI. With JavaScript animations, the browser has no idea that an animation is taking place. His solution was to create a new method, called `mozRequestAnimationFrame()`, that indicates to the browser that some JavaScript code is performing an animation. This allows the browser to optimize appropriately after running some code. All browsers have converged on a prefix-less version of this method, `requestAnimationFrame()`.

The `requestAnimationFrame()` method accepts a single argument, which is a function to call prior to repainting the screen. This function is where you make appropriate changes to DOM styles that will be reflected with the next repaint. In order to create an animation loop, you can chain multiple calls to `requestAnimationFrame()` together in the same way previously done with `setTimeout()`. For example:

```
function updateProgress() {
    var div = document.getElementById("status");
    div.style.width = (parseInt(div.style.width, 10) + 5) + "%";
    if (div.style.left != "100%") {
        requestAnimationFrame(updateProgress);
    }
}
requestAnimationFrame(updateProgress);
```

Because `requestAnimationFrame()` runs the given function only once, you need to call it again manually the next time you want to make a UI change for the animation. You also need to manage when to stop the animation in the same way. The result is a very smooth animation.

So far, `requestAnimationFrame()` has solved the problem of browsers not knowing when a JavaScript animation is happening and the problem of not knowing the best interval, but what about the problem of not knowing when your code will actually execute? That's also covered with the same solution.

The function you pass into `requestAnimationFrame()` actually receives an argument, which is a `DOMHighResTimeStamp` time code (such as the value returned from `performance.now()`) for when the next repaint will actually occur. This is a very important point: `requestAnimationFrame()` actually schedules a repaint for some known point in the future and can tell you when that is. You're then able to determine how best to adjust your animation.

cancelAnimationFrame

Similar to `setTimeout()`, `requestAnimationFrame()` returns a request ID which can be used to cancel the request via `cancelAnimationFrame()`. In the following example, the request callback is enqueued but immediately cancelled:

```
let requestID = window.requestAnimationFrame(() => {
  console.log('Repaint!');
});
window.cancelAnimationFrame(requestID);
```

Performance Throttling with requestAnimationFrame

The name of `requestAnimationFrame` is somewhat misleading with respect to the task being performed. Browsers that support this method are effectively exposing a hook callback queue. The hook is the point just before the browser performs the next repaint. The callback queue is a mutable list of functions, which should be invoked before performing that repaint. Invoking `requestAnimationFrame()` pushes a callback function onto that queue, and there is no limit to the length of the queue.

The behavior of the queued callback does not need to involve animation. However, recursively enqueueing callback functions with `requestAnimationFrame()` ensures that the callback will be invoked at most once per repaint, which is an excellent rate limiting tool. This is especially useful when dealing with frequently invoked code that affects the visual appearance of the page, such as scroll event listeners.

Consider the following naïve implementation, which will invoke the pseudo-expensive operation upon a scroll event being fired from the window object. When scrolling down a web page, this event can be fired hundreds or thousands of times very quickly:

```
function expensiveOperation() {
  console.log('Invoked at', Date.now());
}
```

```

window.addEventListener('scroll', () => {
  expensiveOperation();
});

```

If you wanted to restrict the callback to only occur just before a repaint, you could wrap it inside a `requestAnimationFrame`:

```

function expensiveOperation() {
  console.log('Invoked at', Date.now());
}

window.addEventListener('scroll', () => {
  window.requestAnimationFrame(expensiveOperation);
});

```

This will condense all the callback execution into the repaint hook, but it won't prevent redundant execution per repaint. You can prevent redundant repaint execution by introducing a flag that is set and unset by the callback:

```

let enqueued = false;

function expensiveOperation() {
  console.log('Invoked at', Date.now());
  enqueued = false;
}

window.addEventListener('scroll', () => {
  if (!enqueued) {
    enqueued = true;
    window.requestAnimationFrame(expensiveOperation);
  }
});

```

Because repaints are a very frequent operation, this isn't much of a throttle. Far better is to combine this with a timer, which will throttle the frequency with which this operation can occur. This way, the timer can restrict the real-world time interval at which the operation occurs, and `requestAnimationFrame` controls when in the browser rendering cycle the execution occurs. The following example will prevent the callback from executing more than once every 50ms:

```

let enabled = true;

function expensiveOperation() {
  console.log('Invoked at', Date.now());
}

window.addEventListener('scroll', () => {
  if (enabled) {
    enabled = false;
    window.requestAnimationFrame(expensiveOperation);
    window.setTimeout(() => enabled = true, 50);
  }
});

```

BASIC CANVAS USAGE

The `<canvas>` element requires at least its `width` and `height` attributes to be set in order to indicate the size of the drawing to be created. Any content appearing between the opening and closing tags is fallback data that is displayed only if the `<canvas>` element isn't supported. For example:

```
<canvas id="drawing" width="200" height="200">A drawing of something.</canvas>
```

As with other elements, the `width` and `height` attributes are also available as properties on the DOM element object and may be changed at any time. The entire element may be styled using CSS as well, and the element is invisible until it is styled or drawn upon.

To begin drawing on a canvas, you need to retrieve a drawing context. A reference to a drawing context is retrieved using the `getContext()` method and passing in the name of the context. For example, passing `"2d"` retrieves a 2D context object:

```
let drawing = document.getElementById("drawing");

// make sure <canvas> is completely supported
if (drawing.getContext) {

    let context = drawing.getContext("2d");

    // more code here
}
```

When using the `<canvas>` element, it's important to test for the presence of the `getContext()` method. Some browsers create default HTML element objects for elements that aren't officially part of HTML. In that case, the `getContext()` method would not be available even though `drawing` would contain a valid element reference.

Images created on a `<canvas>` element can be exported using the `toDataURL()` method. This method accepts a single argument, the MIME type format of the image to produce, and is applicable regardless of the context used to create the image. For example, to return a PNG-formatted image from a canvas, use the following:

```
let drawing = document.getElementById("drawing");

// make sure <canvas> is completely supported
if (drawing.getContext) {

    // get data URI of the image
    let imgURI = drawing.toDataURL("image/png");

    // display the image
    let image = document.createElement("img");
    image.src = imgURI;
    document.body.appendChild(image);
}
```

By default, browsers encode the image as PNG unless otherwise specified. Firefox and Opera also support JPEG encoding via `"image/jpeg"`. Because this method was added later in the process, it was adopted in later versions of supporting browsers, including Internet Explorer 9, Firefox 3.5, and Opera 10.

NOTE *The `toDataURL()` method throws an error if an image from a different domain is drawn onto a canvas. More details are available later in this chapter.*

THE 2D CONTEXT

The 2D drawing context provides methods for drawing simple 2D shapes such as rectangles, arcs, and paths. The coordinates in a 2D context begin at the upper-left of the `<canvas>` element, which is considered point (0, 0). All coordinate values are calculated in relation to that point, with `x` increasing to the right and `y` increasing toward the bottom. By default, the `width` and `height` indicate how many pixels are available in each direction.

Fills and Strokes

There are two basic drawing operations on the 2D context: fill and stroke. Fill automatically fills in the shape with a specific style (color, gradient, or image) while stroke colors only the edges. Most of the 2D context operations have both fill and stroke variants, and how they are displayed is based on a couple of properties: `fillStyle` and `strokeStyle`.

Both properties can be set to a string, a gradient object, or a pattern object, and both default to a value of `"#000000"`. A string value indicates a color defined using one of the various CSS color formats: name, hex code, `rgb`, `rgba`, `hsl`, or `hsla`. For example:

```
let drawing = document.getElementById("drawing");

// make sure <canvas> is completely supported
if (drawing.getContext) {

    let context = drawing.getContext("2d");
    context.strokeStyle = "red";
    context.fillStyle = "#0000ff";
}
```

This code sets the `strokeStyle` to `"red"` (a named CSS color) and `fillStyle` to `"#0000ff"` (also known as blue). All drawing operations involving stroke and fill will use these styles until the properties are changed again. These properties can also be set to a gradient or a pattern, both of which are discussed later in this chapter.

Drawing Rectangles

The only shape that can be drawn directly on the 2D drawing context is the rectangle. There are three methods for working with rectangles: `fillRect()`, `strokeRect()`, and `clearRect()`. Each of these methods accepts four arguments: the `x`-coordinate of the rectangle, the `y`-coordinate of the rectangle, the width of the rectangle, and the height of the rectangle. Each of these arguments is considered to be in pixels.

The `fillRect()` method is used to draw a rectangle that is filled with a specific color onto the canvas. The fill color is specified using the `fillStyle` property. Consider the following example:

```
let drawing = document.getElementById("drawing");

// make sure <canvas> is completely supported
if (drawing.getContext) {
  let context = drawing.getContext("2d");

  /*
   * Based on Mozilla's documentation:
   * http:// developer.mozilla.org/en/docs/Canvas_tutorial:Basic_usage
   */

  // draw a red rectangle
  context.fillStyle = "#ff0000";
  context.fillRect(10, 10, 50, 50);

  // draw a blue rectangle that's semi-transparent
  context.fillStyle = "rgba(0,0,255,0.5)";
  context.fillRect(30, 30, 50, 50);
}
```

This code first sets the `fillStyle` to red and draws a rectangle located at (10, 10) that's 50 pixels tall and wide. Next, it sets the `fillStyle` to a semitransparent blue color using `rgba()` format and draws another rectangle that overlaps the first. The result is that you can see the red rectangle through the blue rectangle (see Figure 18-1).



FIGURE 18-1:

The `strokeRect()` method draws a rectangle outline using the color specified with the `strokeStyle` property. Here is an example:

```
let drawing = document.getElementById("drawing");

// make sure <canvas> is completely supported
if (drawing.getContext) {
  let context = drawing.getContext("2d");

  /*
   * Based on Mozilla's documentation:
   * http:// developer.mozilla.org/en/docs/Canvas_tutorial:Basic_usage
   */

  // draw a red outlined rectangle
  context.strokeStyle = "#ff0000";
  context.strokeRect(10, 10, 50, 50);

  // draw a blue outlined rectangle that's semi-transparent
  context.strokeStyle = "rgba(0,0,255,0.5)";
  context.strokeRect(30, 30, 50, 50);
}
```

This code also draws two rectangles that overlap; however, they are just outlines rather than filled rectangles (see Figure 18-2).

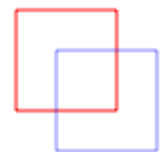

FIGURE 18-2:

NOTE *The size of the stroke is controlled by the `lineWidth` property, which can be set to any whole number. Likewise, a `lineCap` property describes the shape that should be used at the end of lines ("butt", "round", or "square") and `lineJoin` indicates how lines should be joined ("round", "bevel", or "miter").*

You can erase an area of the canvas by using the `clearRect()` method. This method is used to make an area of the drawing context transparent. By drawing shapes and then clearing specific areas, you are able to create interesting effects, such as cutting out a section of another shape. Consider the following example:

```
let drawing = document.getElementById("drawing");

// make sure <canvas> is completely supported
if (drawing.getContext) {
  let context = drawing.getContext("2d");
  /*
   * Based on Mozilla's documentation:
   * http:// developer.mozilla.org/en/docs/Canvas_tutorial:Basic_usage
   */

  // draw a red rectangle
  context.fillStyle = "#ff0000";
  context.fillRect(10, 10, 50, 50);

  // draw a blue rectangle that's semi-transparent
  context.fillStyle = "rgba(0,0,255,0.5)";
  context.fillRect(30, 30, 50, 50);

  // clear a rectangle that overlaps both of the previous rectangles
  context.clearRect(40, 40, 10, 10);
}
```

Here, two filled rectangles overlap one another and then a small rectangle is cleared inside of that overlapping area. Figure 18-3 shows the result.



FIGURE 18-3:

Drawing Paths

The 2D drawing context supports a number of methods for drawing paths on a canvas. Paths allow you to create complex shapes and lines. To start creating a path, you must first call `beginPath()` to indicate that a new path has begun. After that, the following methods can be called to create the path:

- `arc(x, y, radius, startAngle, endAngle, counterclockwise)`—Draws an arc centered at point (x, y) with a given radius and between `startAngle` and `endAngle` (expressed in radians). The last argument is a Boolean indicating if `startAngle` and `endAngle` should be calculated counterclockwise instead of clockwise.

- `arcTo(x1, y1, x2, y2, radius)`—Draws an arc from the last point to (x_2, y_2) , passing through (x_1, y_1) with the given radius.
- `bezierCurveTo(c1x, c1y, c2x, c2y, x, y)`—Draws a curve from the last point to the point (x, y) using the control points $(c1x, c1y)$ and $(c2x, c2y)$.
- `lineTo(x, y)`—Draws a line from the last point to the point (x, y) .
- `moveTo(x, y)`—Moves the drawing cursor to the point (x, y) without drawing a line.
- `quadraticCurveTo(cx, cy, x, y)`—Draws a quadratic curve from the last point to the point (x, y) using a control point of (cx, cy) .
- `rect(x, y, width, height)`—Draws a rectangle at point (x, y) with the given width and height. This is different from `strokeRect()` and `fillRect()` in that it creates a path rather than a separate shape.

Once the path has been created, you have several options. To draw a line back to the origin of the path, you can call `closePath()`. If the path is already completed and you want to fill it with `fillStyle`, call the `fill()` method. Another option is to stroke the path by calling the `stroke()` method, which uses `strokeStyle`. The last option is to call `clip()`, which creates a new clipping region based on the path.

As an example, consider the following code for drawing the face of a clock without the numbers:

```
let drawing = document.getElementById("drawing");

// make sure <canvas> is completely supported
if (drawing.getContext) {
  let context = drawing.getContext("2d");

  // start the path
  context.beginPath();

  // draw outer circle
  context.arc(100, 100, 99, 0, 2 * Math.PI, false);

  // draw inner circle
  context.moveTo(194, 100);
  context.arc(100, 100, 94, 0, 2 * Math.PI, false);

  // draw minute hand
  context.moveTo(100, 100);
  context.lineTo(100, 15);

  // draw hour hand
  context.moveTo(100, 100);
  context.lineTo(35, 100);

  // stroke the path
  context.stroke();
}
```

This example draws two circles using `arc()`: an outer one and an inner one to create a border around the clock. The outer circle has a radius of 99 pixels and is centered at (100, 100), which is the center of the canvas. To draw a complete circle, you must start at an angle of 0 radians and draw all the way around to 2π radians (calculated using `Math.PI`). Before drawing the inner circle, you must move the path to a point that will be on the circle to avoid an additional line being drawn. The second call to `arc()` uses a slightly smaller radius for the border effect. After that, combinations of `moveTo()` and `lineTo()` are used to draw the hour and minute hands. The last step is to call `stroke()`, which makes the image appear as shown in Figure 18-4.

Paths are the primary drawing mechanism for the 2D drawing context because they provide more control over what is drawn. Because paths are used so often, there is also a method called `isPointInPath()`, which accepts an x-coordinate and a y-coordinate as arguments. This method can be called anytime before the path is closed to determine if a point exists on the path, as shown here:

```
if (context.isPointInPath(100, 100)) {
    alert("Point (100, 100) is in the path.");
}
```

The path API for the 2D drawing context is robust enough to create very complex images using multiple fill styles, stroke styles, and more.

Drawing Text

Because it's often necessary to mix text and graphics, the 2D drawing context provides methods to draw text. There are two methods for drawing text, `fillText()` and `strokeText()`, and each takes four arguments: the string to draw, the x-coordinate, the y-coordinate, and an optional maximum pixel width to draw. Both methods base their drawing on the following three properties:

- `font`—Indicates the font style, size, and family in the same manner specified in CSS, such as "10px Arial".
- `textAlign`—Indicates how the text should be aligned. Possible values are "start", "end", "left", "right", and "center". It's recommended to use "start" and "end" instead of "left" and "right" as these are more indicative of rendering in both left-to-right languages and right-to-left languages.
- `textBaseline`—Indicates the baseline of the text. Possible values are "top", "hanging", "middle", "alphabetic", "ideographic", and "bottom".

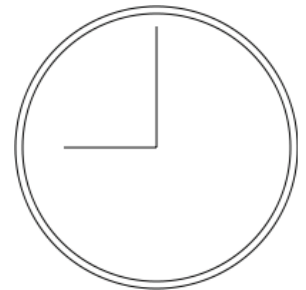

FIGURE 18-4:

These properties have a default value, so there's no need to set them each time you want to draw text. The `fillText()` method uses the `fillStyle` property to draw the text, whereas the `strokeText()` method uses the `strokeStyle` property. You will probably use `fillText()` most of the time because this mimics normal text rendering on web pages. For example, the following renders a 12 at the top of the clock created in the previous section:

```
context.font = "bold 14px Arial";
context.textAlign = "center";
```

```
context.textBaseline = "middle";
context.fillText("12", 100, 20);
```

The resulting image is displayed in Figure 18-5.

Because `textAlign` is set to "center" and `textBaseline` is set to "middle", the coordinates (100, 80) indicate the horizontal and vertical center and top coordinates for the text. If `textAlign` were "start", then the x-coordinate would represent the left coordinate of the text in a left-to-right language while "end" would make the x-coordinate represent the right coordinate in a left-to-right language. For example:

```
// normal
context.font = "bold 14px Arial";
context.textAlign = "center";
context.textBaseline = "middle";
context.fillText("12", 100, 20);
// start-aligned
context.textAlign = "start";
context.fillText("12", 100, 40);
// end-aligned
context.textAlign = "end";
context.fillText("12", 100, 60);
```

The string "12" is drawn three times, each using the same x-coordinate but with three different `textAlign` values. The y-coordinate values are also incremented so that the strings don't render on top of one another. The resulting image is shown in Figure 18-6.

The vertical line of the clock is directly at the center so the alignment of the text becomes obvious. You can similarly adjust how the text is aligned vertically by altering `textBaseline`. Setting to "top" means that the y-coordinate is the top of the text, "bottom" means it's the bottom, and "hanging", "alphabetic", and "ideographic" refer to specific baseline coordinates of a font.

Because drawing text is quite complicated, especially when you want text to render within a specific area, the 2D context provides a little extra help to determine the dimensions of text via the `measureText()` method. This method accepts a single argument, the text to draw, and returns a `TextMetrics` object. The returned object currently has only one property, `width`, but the intent is to provide more metrics in the future.

The `measureText()` method uses the current values for `font`, `textAlign`, and `textBaseline` to calculate the size of the specified text. For example, suppose you want to fit the text "Hello world!" within a rectangle that is 140 pixels wide. The following code starts with a font size of 100 pixels and decrements until the text fits:

```
let fontSize = 100;
context.font = fontSize + "px Arial";
while(context.measureText("Hello world!").width > 140) {
  fontSize--;
```

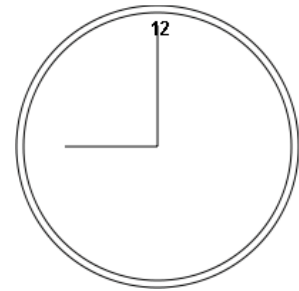

FIGURE 18-5:

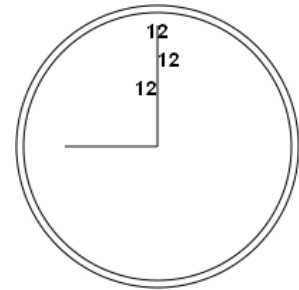

FIGURE 18-6:

```

    context.font = fontSize + "px Arial";
  }
  context.fillText("Hello world!", 10, 10);
  context.fillText("Font size is " + fontSize + "px", 10, 50);

```

There is also a fourth argument for both `fillText()` and `strokeText()`, which is the maximum width of the text. This argument is optional and hasn't been implemented in all browsers yet (Firefox 4 was the first to implement it). When provided, calling `fillText()` or `strokeText()` with a string that will not fit within the maximum width results in the text being drawn with the correct character height, but the characters are scaled horizontally to fit. Figure 18-7 shows this effect.

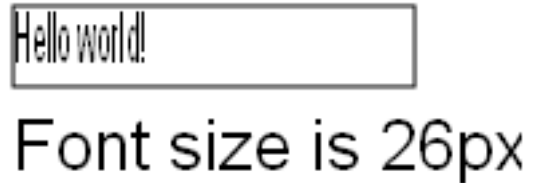

FIGURE 18-7:

Text drawing is one of the more complex drawing operations and, as such, not all portions of the API have been implemented in the all browsers that support the `<canvas>` element.

Transformations

Context transformations allow the manipulation of images drawn onto the canvas. The 2D drawing context supports all of the basic drawing transformations. When the drawing context is created, the transformation matrix is initialized with default values that cause all drawing operations to be applied directly as they are described. Applying transformations to the drawing context causes operations to be applied using a different transformation matrix and thus produces a different result.

The transformation matrix can be augmented by using any of the following methods:

- `rotate(angle)`—Rotates the image around the origin by `angle` radians.
- `scale(scaleX, scaleY)`—Scales the image by a multiple of `scaleX` in the x dimension and by `scaleY` in the y dimension. The default value for both `scaleX` and `scaleY` is 1.0.
- `translate(x, y)`—Moves the origin to the point (`x`, `y`). After performing this operation, the coordinates (0, 0) are located at the point previously described as (`x`, `y`).
- `transform(m1_1, m1_2, m2_1, m2_2, dx, dy)`—Changes the transformation matrix directly by multiplying by the matrix described as this:

```

m1_1 m1_2 dx
m2_1 m2_2 dy
0    0    1

```
- `setTransform(m1_1, m1_2, m2_1, m2_2, dx, dy)`—Resets the transformation matrix to its default state and then calls `transform()`.

Transformations can be as simple or as complex as necessary. For example, it may be easier to draw the hands on the clock in the previous example by translating the origin to the center of the clock and

then drawing the hands from there. Consider the following:

```
let drawing = document.getElementById("drawing");

// make sure <canvas> is completely supported
if (drawing.getContext) {
  let context = drawing.getContext("2d");

  // start the path
  context.beginPath();

  // draw outer circle
  context.arc(100, 100, 99, 0, 2 * Math.PI, false);

  // draw inner circle
  context.moveTo(194, 100);
  context.arc(100, 100, 94, 0, 2 * Math.PI, false);

  // translate to center
  context.translate(100, 100);

  // draw minute hand
  context.moveTo(0, 0);
  context.lineTo(0, -85);

  // draw hour hand
  context.moveTo(0, 0);
  context.lineTo(-65, 0);

  // stroke the path
  context.stroke();
}
```

After translating the origin to (100, 100), the center of the clock face, it's just a matter of simple math to draw the lines in the same direction. All math is now based on (0, 0) instead of (100, 100). You can go further, moving the hands of the clock by using the `rotate()` method as shown here:

```
let drawing = document.getElementById("drawing");

// make sure <canvas> is completely supported
if (drawing.getContext) {
  let context = drawing.getContext("2d");

  // start the path
  context.beginPath();

  // draw outer circle
  context.arc(100, 100, 99, 0, 2 * Math.PI, false);

  // draw inner circle
  context.moveTo(194, 100);
  context.arc(100, 100, 94, 0, 2 * Math.PI, false);

  // translate to center
  context.translate(100, 100);
```

```

// rotate the hands
context.rotate(1);

// draw minute hand
context.moveTo(0, 0);
context.lineTo(0, -85);

// draw hour hand
context.moveTo(0, 0);
context.lineTo(-65, 0);

// stroke the path
context.stroke();
}

```

Because the origin has already been translated to the center of the clock, the rotation is applied from that point. This means that the hands are anchored at the center and then rotated around to the right. The result is displayed in Figure 18-8.

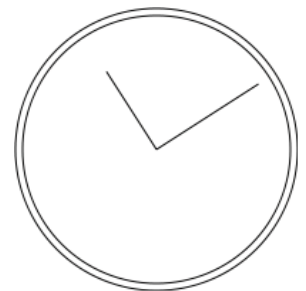

FIGURE 18-8:

All of these transformations, as well as properties like `fillStyle` and `strokeStyle`, remain set on the context until explicitly changed. Although there's no way to explicitly reset everything to their default values, there are two methods that can help keep track of changes.

Whenever you want to be able to return to a specific set of properties and transformations, call the `save()` method. Once called, this method pushes all of the settings at the moment onto a stack for safekeeping.

You can then go on to make other changes to the context. When you want to go back to the previous settings, call the `restore()` method, which pops the settings stack and restores all of the settings. You can keep calling `save()` to store more settings on the stack and then systematically go back through them using `restore()`. Here is an example:

```

context.fillStyle = "#ff0000";
context.save();

context.fillStyle = "#00ff00";
context.translate(100, 100);
context.save();

context.fillStyle = "#0000ff";
context.fillRect(0, 0, 100, 200); // draws blue rectangle at (100, 100)

context.restore();
context.fillRect(10, 10, 100, 200); // draws green rectangle at (110, 110)

context.restore();
context.fillRect(0, 0, 100, 200); // draws red rectangle at (0, 0)

```

In this code, the `fillStyle` is set to red and then `save()` is called. Next, the `fillStyle` is changed to green, and the coordinates are translated to (100, 100). Once again, `save()` is called to save these settings. The `fillStyle` property is then set to blue and a rectangle is drawn. Because the coordinates

are translated, the rectangle actually ends up being drawn at (100, 100). When `restore()` is called, `fillStyle` is set back to green, so the next rectangle that's drawn is green. This rectangle is drawn at (110, 110) because the translation is still in effect. When `restore()` is called one more time, the translation is removed and `fillStyle` is set back to red. The last rectangle is drawn at (0, 0).

Note that `save()` saves only the settings and transformations applied to the drawing context but not the contents of the drawing context.

Drawing Images

The 2D drawing context has built-in support for working with images. If you have an existing image that should be drawn on the canvas, you can do so using the `drawImage()` method. This method can be called with three different sets of arguments based on the desired result. The simplest call is to pass in an HTML `` element, as well as the destination x- and y-coordinates, which simply draws the image at the specified location. Consider this example:

```
let image = document.images[0];
context.drawImage(image, 10, 10);
```

This code gets the first image in the document and draws it on the context at position (10, 10). The image is drawn in the same scale as the original. You can change how the image is drawn by adding two more arguments: the destination width and destination height. This scales the drawing without affecting the transformation matrix of the context. Consider this example:

```
context.drawImage(image, 50, 10, 20, 30);
```

When this code is executed, the image is scaled to be 20 pixels wide by 30 pixels tall.

You can also select just a region of the image to be drawn onto the context. This is done by providing nine arguments to `drawImage()`: the image to draw, the source x-coordinate, the source y-coordinate, the source width, the source height, the destination x-coordinate, the destination y-coordinate, the destination width, and the destination height. Using this overload of `drawImage()` gives you the most control. Consider this example:

```
context.drawImage(image, 0, 10, 50, 50, 0, 100, 40, 60);
```

Here, only part of the image is drawn on the canvas. That part of the image begins at point (0, 10) and is 50 pixels wide and 50 pixels tall. The image is drawn to point (0, 100) on the context and scaled to fit in a 40×60 area.

These drawing operations allow you to create interesting effects such as those shown in Figure 18-9.

In addition to passing in an HTML `` element as the first argument, you can also pass in another `<canvas>` element to draw the contents of one canvas onto another.

The `drawImage()` method, in combination with other methods, can easily be used to perform basic image manipulation, the result of which can be retrieved using `toDataURL()`. There is, however, one instance where this won't work: if an image from a different origin than the page is drawn onto the context. In that case, calling `toDataURL()` throws an error.



FIGURE 18-9:

For example, if a page hosted on `www.example.com` draws an image hosted on `www.wrox.com`, the context is considered "dirty" and an error is thrown.

Shadows

The 2D context will automatically draw a shadow along with a shape or path based on the value of several properties:

- `shadowColor`—The CSS color in which the shadow should be drawn. The default is black.
- `shadowOffsetX`—The x-coordinate offset from the x-coordinate of the shape or path. The default is 0.
- `shadowOffsetY`—The y-coordinate offset from the y-coordinate of the shape or path. The default is 0.
- `shadowBlur`—The number of pixels to blur. If set to 0, the shadow has no blur. The default is 0.

Each of these properties can be read and written on the `context` object. You just need to set the values appropriately before drawing and the shadows are drawn automatically. For example:

```
let context = drawing.getContext("2d");
// setup shadow
context.shadowOffsetX = 5;
context.shadowOffsetY = 5;
context.shadowBlur = 4;
context.shadowColor = "rgba(0, 0, 0, 0.5)";
// draw a red rectangle
context.fillStyle = "#ff0000";
context.fillRect(10, 10, 50, 50);
// draw a blue rectangle
context.fillStyle = "rgba(0,0,255,1)";
context.fillRect(30, 30, 50, 50);
```

A shadow is drawn using the same styles for both rectangles, resulting in the image displayed in Figure 18-10.



FIGURE 18-10:

Gradients

Gradients are represented by an instance of `CanvasGradient` and are very simple to create and modify using the 2D context. To create a new linear gradient, call the `createLinearGradient()` method. This method accepts four arguments: the starting x-coordinate, the starting y-coordinate, the ending x-coordinate, and the ending y-coordinate. Once called, the method creates a new `CanvasGradient` object of the size you specified and returns the instance.

Once you have the `gradient` object, the next step is to assign color stops using the `addColorStop()` method. This method accepts two arguments: the location of the color stop and a CSS color. The color stop location is a number between 0 (the first color) and 1 (the last color). For example:

```
let gradient = context.createLinearGradient(30, 30, 70, 70);
gradient.addColorStop(0, "white");
gradient.addColorStop(1, "black");
```

The gradient object now represents a gradient that is drawn from point (30, 30) to point (70, 70) on the canvas. The starting color is white and the stopping color is black. You can now set the `fillStyle` or `strokeStyle` properties to this value to draw a shape using the gradient:

```
// draw a red rectangle
context.fillStyle = "#ff0000";
context.fillRect(10, 10, 50, 50);
// draw a gradient rectangle
context.fillStyle = gradient;
context.fillRect(30, 30, 50, 50);
```

In order for the gradient to be drawn over the entire rectangle and not just part of it, the coordinates need to match up. This code produces the drawing in Figure 18-11.

If the rectangle isn't drawn in exactly this spot, then only part of the gradient is displayed. For example:

```
context.fillStyle = gradient;
context.fillRect(50, 50, 50, 50);
```

This code creates a rectangle with only a small amount of white in the upper-left corner. That's because the rectangle is drawn at the midpoint of the gradient, where the color transition is almost complete. The rectangle is therefore mostly black because gradients do not repeat. Keeping the gradient lined up with your shapes is important, and sometimes using a function to calculate the appropriate coordinates is useful. For example:

```
function createRectLinearGradient(context, x, y, width, height) {
  return context.createLinearGradient(x, y, x+width, y+height);
}
```

This function creates a gradient based on the starting x- and y-coordinates, along with a width and height, so that the same numbers can be used as `fillRect()`:

```
let gradient = createRectLinearGradient(context, 30, 30, 50, 50);
gradient.addColorStop(0, "white");
gradient.addColorStop(1, "black");
// draw a gradient rectangle
context.fillStyle = gradient;
context.fillRect(30, 30, 50, 50);
```

Keeping track of coordinates is an important and tricky aspect of using canvas. Helper functions such as `createRectLinearGradient()` can take some of the pain out of managing coordinates.

Radial gradients are created using the `createRadialGradient()` method. This method accepts six arguments corresponding to the center of a circle and its radius. The first three arguments define the starting circle's center (x and y) and radius, while the last three define the same for the ending circle. When thinking about radial gradients, you will find it helps to think of a long cylinder where you're defining the size of the circle on each end. By making one circle smaller and the other larger, you've effectively made a cone, and you rotate that cone around by moving the center of each circle.

To create a radial gradient that starts in the center of a shape and continues out, you need to set the center of both circles to the same origin. For example, to create a radial gradient in the center of the



FIGURE 18-11:

rectangle in the previous example, both circles must be centered at (55, 55). That's because the rectangle is drawn from point (30, 30) to point (80, 80). Here's the code:

```
let gradient = context.createRadialGradient(55, 55, 10, 55, 55, 30);
gradient.addColorStop(0, "white");
gradient.addColorStop(1, "black");
// draw a red rectangle
context.fillStyle = "#ff0000";
context.fillRect(10, 10, 50, 50);
// draw a gradient rectangle
context.fillStyle = gradient;
context.fillRect(30, 30, 50, 50);
```

Running this code results in the drawing displayed in Figure 18-12.

Radial gradients are a little bit more difficult to work with because of the complexities of their creation, but generally you'll end up using the same center for both starting circle and ending circle and just altering the radii of the circles for most basic effects.



FIGURE 18-12:

Patterns

Patterns are simply repeating images that may be used to fill or stroke a shape. To create a new pattern, call the `createPattern()` method and pass in two arguments: an HTML `` element and a string indicating how the image should be repeated. The second argument is the same as the values for the CSS `background-repeat` property: "repeat", "repeat-x", "repeat-y", and "no-repeat". For example:

```
let image = document.images[0],
    pattern = context.createPattern(image, "repeat");
// draw a rectangle
context.fillStyle = pattern;
context.fillRect(10, 10, 150, 150);
```

Keep in mind that, like gradients, a pattern actually starts at point (0, 0) on the canvas. Setting the fill style to a pattern means revealing the pattern in the specified location rather than starting to draw at that position. This code results in a page that looks like Figure 18-13.

The first argument for `createPattern()` can also be a `<video>` element or another `<canvas>` element.

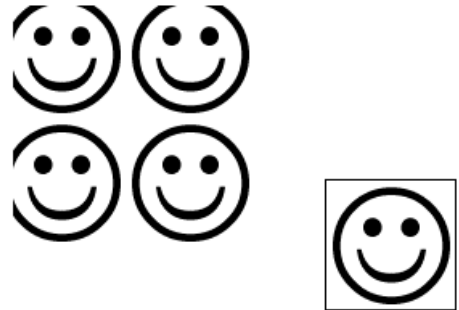

FIGURE 18-13:

Working with Image Data

One of the more powerful aspects of the 2D context is the ability to retrieve raw image data using the `getImageData()` method. This method accepts four arguments: the left and top position of the first pixel whose data should be retrieved, and the pixel

width and the pixel height to retrieve. For instance, to get image data for a 50 by 50 area starting at (10, 5), use the following:

```
let imageData = context.getImageData(10, 5, 50, 50);
```

The returned object is an instance of `ImageData`. Each `ImageData` object contains just three properties: `width`, `height`, and `data`. The `data` property is an array that contains the raw pixel information for the image. Each pixel is actually represented as four items in the `data` array, one each for red, green, blue, and alpha. So the data for the first pixel is contained in items 0 through 3, such as:

```
let data = imageData.data,
    red = data[0],
    green = data[1],
    blue = data[2],
    alpha = data[3];
```

Each value in the array is a number between 0 and 255, inclusive. Having access to the raw image data allows you to manipulate the image in a variety of ways. For example, a simple grayscale filter can be created by changing the image data:

```
let drawing = document.getElementById("drawing");
// make sure <canvas> is completely supported
if (drawing.getContext) {
  let context = drawing.getContext("2d"),
      image = document.images[0],
      imageData, data,
      i, len, average,
      red, green, blue, alpha;

  // draw regular size
  context.drawImage(image, 0, 0);

  // get the image data
  imageData = context.getImageData(0, 0, image.width, image.height);
  data = imageData.data;
  for (i=0, len=data.length; i < len; i+=4) {

    red = data[i];
    green = data[i+1];
    blue = data[i+2];
    alpha = data[i+3];

    // get the average of rgb
    average = Math.floor((red + green + blue) / 3);

    // set the colors, leave alpha alone
    data[i] = average;
    data[i+1] = average;
    data[i+2] = average;

  }

  // assign back to image data and display
  imageData.data = data;
  context.putImageData(imageData, 0, 0);
}
```

This example first draws an image onto the canvas and then retrieves its image data. A `for` loop iterates over each pixel in the image data. Note that each trip through the loop adds 4 to the value of `i`. Once the red, green, and blue values are retrieved, they are averaged together to get a new value. Then each of the values is set back to that average, effectively washing out the color and leaving only a gray of similar brightness in its place. The data array is then assigned back onto the `imageData` object. After that, the `putImageData()` method is called to draw the image data back to the canvas. The result is a grayscale version of the image.

Of course, grayscale isn't the only type of filter that can be implemented by manipulating raw pixel values. For more information on creating filters with raw image data, see "Making Image Filters with Canvas" by Ilmari Heikkinen (www.js15rocks.com/en/tutorials/canvas/imagefilters/).

NOTE *Image data is available only if the canvas isn't dirty from loading a cross-domain resource. Attempting to access image data when the canvas is dirty causes a JavaScript error.*

Compositing

There are two properties that apply to all drawing done on the 2D context: `globalAlpha` and `globalCompositionOperation`. The `globalAlpha` property is a number between 0 and 1, inclusive, that specifies the alpha value for all drawings. The default value is 0. If all of the upcoming drawings should be done with the same alpha, set `globalAlpha` to the appropriate value, perform the drawings, and then set `globalAlpha` back to 0. For example:

```
// draw a red rectangle
context.fillStyle = "#ff0000";
context.fillRect(10, 10, 50, 50);
// change the global alpha
context.globalAlpha = 0.5;
// draw a blue rectangle
context.fillStyle = "rgba(0,0,255,1)";
context.fillRect(30, 30, 50, 50);
// reset
context.globalAlpha = 0;
```

In this example, a blue rectangle is drawn on top of a red rectangle. Because `globalAlpha` is set to 0.5 before drawing the blue rectangle, it becomes partially transparent, allowing the red rectangle to be seen through the blue.

The `globalCompositionOperation` property indicates how newly drawn shapes should merge with the already-existing image on the context. This property is a string value of one of the following:

- `source-over` (default)—New drawing is drawn on top of the existing image.
- `source-in`—New drawing is drawn only where it overlaps the existing image. Everything else becomes transparent.
- `source-out`—New drawing is drawn only where it does not overlap the existing image. Everything else becomes transparent.

- `source-atop`—New drawing is drawn only where it overlaps the existing image. The existing image is otherwise unaffected.
- `destination-over`—New drawing is drawn underneath the existing image, visible only through previously transparent pixels.
- `destination-in`—New drawing is drawn underneath the existing image, and all places where the two images do not overlap become transparent.
- `destination-out`—New drawing erases the parts of the existing image where they overlap.
- `destination-atop`—New drawing is drawn behind the existing image. The existing image becomes transparent where there is no overlap with new drawing.
- `lighter`—New drawing is drawn by combining its values with the existing image values to create a lighter image.
- `copy`—New drawing erases the existing image and replaces it completely.
- `xor`—New drawing is drawn by XORing the image data with the existing image.

The descriptions of these composite operations are difficult to represent in words or black-and-white images. Here's a simple example:

```
// draw a red rectangle
context.fillStyle = "#ff0000";
context.fillRect(10, 10, 50, 50);
// set composite operation
context.globalCompositeOperation = "destination-over";
// draw a blue rectangle
context.fillStyle = "rgba(0,0,255,1)";
context.fillRect(30, 30, 50, 50);
```

Even though the blue rectangle would normally be drawn over the red, changing `globalCompositeOperation` to `"destination-over"` means that the red rectangle actually ends up on top of the blue.

When using `globalCompositeOperation`, be sure to test across a wide variety of browsers. There are still significant differences between how these operations are implemented cross-browser. Safari and Chrome still have several issues with these operations, which can be seen by going to the previously mentioned URL and comparing the rendering to that of Internet Explorer or Firefox.

WEBGL

WebGL is a 3D context for canvas. Unlike other web technologies, WebGL is not specified by the W3C. Instead, the Khronos Group is developing the specification. According to its website, “The Khronos Group is a not for profit, member-funded consortium focused on the creation of royalty-free open standards for parallel computing, graphics, and dynamic media on a wide variety of platforms and devices.” The Khronos Group has also worked on other graphics APIs, such as OpenGL ES 2.0, which is the basis for WebGL in the browser.

3D graphics languages such as OpenGL are complex topics, and it is beyond the scope of this book to cover all concepts. Familiarity with OpenGL ES 2.0 is recommended for using WebGL as many concepts map directly.

This section assumes a working knowledge of OpenGL ES 2.0 concepts and simply attempts to describe how certain parts of OpenGL ES 2.0 have been implemented in WebGL. For more information on OpenGL, please visit www.opengl.org, and for an excellent series of WebGL tutorials, please visit www.learningwebgl.com.

NOTE *Typed arrays are an important part of performing operations in WebGL. They are covered in depth in the Collection Reference Types chapter.*

The WebGL Context

The WebGL 2.0 context name in fully supporting browsers is "webgl2". The WebGL 1.0 context name in fully supporting browsers is "webgl". If the browser doesn't support WebGL, then attempting to retrieve a WebGL context returns `null`. You should always check the returned value before attempting to use the context:

```
let drawing = document.getElementById("drawing");

// make sure <canvas> is completely supported
if (drawing.getContext) {
  let gl = drawing.getContext("webgl");
  if (gl) {
    // proceed with WebGL
  }
}
```

The WebGL context object is typically called `gl`. Most WebGL applications and examples use this convention because OpenGL ES 2.0 methods and values typically begin with "gl". Doing so means the JavaScript code reads more closely like an OpenGL program.

WebGL Basics

Once the WebGL context is established, you're ready to start 3D drawing. As mentioned previously, because WebGL is a web version of OpenGL ES 2.0, the concepts discussed in this section are really OpenGL concepts as implemented in JavaScript.

You can specify options for the WebGL context by passing in a second argument to `getContext()`. The argument is an object containing one or more of the following properties:

- `alpha`—When set to `true`, creates an alpha channel buffer for the context. Default is `true`.
- `depth`—When set to `true`, a 16-bit depth buffer is available. Default is `true`.
- `stencil`—When set to `true`, an 8-bit stencil buffer is available. Default is `false`.
- `antialias`—When set to `true`, antialiasing will be performed using the default mechanism. Default is `true`.

- `premultipliedAlpha`—When set to `true`, the drawing buffer is assumed to have premultiplied alpha values. Default is `true`.
- `preserveDrawingBuffer`—When set to `true`, the drawing buffer is preserved after drawing is completed. Default is `false`. Recommended to change only if you know exactly what this does, as there may be performance implications.

The options object is passed in like this:

```
let drawing = document.getElementById("drawing");

// make sure <canvas> is completely supported
if (drawing.getContext) {

    let gl = drawing.getContext("webgl", { alpha: false });
    if (gl) {
        // proceed with WebGL
    }
}
```

Most of the context options are for advanced use. In many cases, the default values will serve your purpose.

Some browsers may throw an error if the WebGL context can't be created via `getContext()`. For that reason, it's best to wrap the call in a `try-catch` block:

```
Insert IconMargin      [download]let drawing = document.getElementById("drawing"),
    gl;

// make sure <canvas> is completely supported
if (drawing.getContext) {
    try {
        gl = drawing.getContext("webgl");
    } catch (ex) {
        // noop
    }
    if (gl) {
        // proceed with WebGL
    } else {
        alert("WebGL context could not be created.");
    }
}
```

Constants

If you're familiar with OpenGL, then you're familiar with the large number of constants used for operations. These constants are named in OpenGL with a prefix of `GL_`. In WebGL, each constant is available on the WebGL context object without the `GL_` prefix. For example, the `GL_COLOR_BUFFER_BIT` constant is available as `gl.COLOR_BUFFER_BIT`. WebGL supports most OpenGL constants in this manner (some constants are not available).

Method Naming

Many method names in OpenGL, and so also in WebGL, tend to include information about the type of data to be used with the method. If a method can accept different types and numbers of arguments then it is suffixed to indicate the expected input. The method will indicate the number of arguments (1 through 4) followed by the data type (“f” for float and “i” for int). For example, `gl.uniform4f()` expects four floats to be passed in and `gl.uniform3i()` expects three integers to be passed in.

Many methods also allow an array to be passed in instead of individual arguments. This is indicated by the letter “v,” which is short for vector. So `gl.uniform3iv()` accepts an array of integers with three values. Keep this convention in mind throughout the discussion of WebGL.

Getting Ready to Draw

One of the first steps when working on a WebGL context is to clear the `<canvas>` with a solid color to prepare for drawing. To do this, you first must assign the color to use via the `clearColor()` method. This method accepts four arguments: red, green, blue, and alpha. Each argument must be a number between 0 and 1 defining the strength of value as part of a final color. Consider the following example:

```
gl.clearColor(0, 0, 0, 1); // black
gl.clear(gl.COLOR_BUFFER_BIT);
```

This code sets the clear color buffer value to black and then calls the `clear()` method, which is the equivalent of `glClear()` in OpenGL. Providing the argument `gl.COLOR_BUFFER_BIT` tells WebGL to use the previously defined color to fill the area. Generally speaking, all drawing operations begin with a call to clear the area for drawing.

Viewports and Coordinates

To get started, it’s a good idea to define the WebGL viewport. By default, the viewport is set to use the entire `<canvas>` area. To change the viewport, call the `viewport()` method and pass in the `x`, `y`, `width`, and `height` of the viewport relative to the `<canvas>` element. For example, this call uses the entire `<canvas>` element:

```
gl.viewport(0, 0, drawing.width,
drawing.height);
```

The viewport is defined using a different coordinate system than is typically used in a web page. The `x`- and `y`-coordinates start with `(0, 0)` at the bottom-left of the `<canvas>` element and increase toward the top and right, which can be defined as point `(width-1, height-1)` (see Figure 18-14).

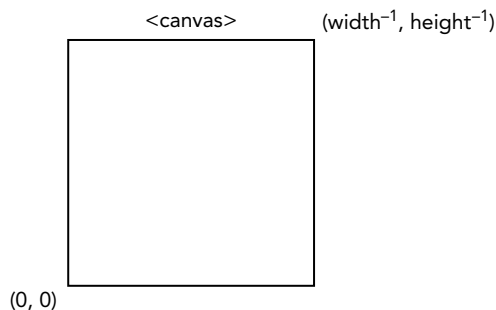

FIGURE 18-14:

Knowing how the viewport is defined allows you to use just a part of the `<canvas>` element for drawing. Consider the following examples:

```
// viewport is a quarter of the <canvas> in the lower-left corner
gl.viewport(0, 0, drawing.width/2, drawing.height/2);
// viewport is a quarter of the <canvas> in the upper-left corner
gl.viewport(0, drawing.height/2, drawing.width/2, drawing.height/2);
// viewport is a quarter of the <canvas> in the lower-right corner
gl.viewport(drawing.width/2, 0, drawing.width/2, drawing.height/2);
```

The coordinate system within a viewport is different than the coordinate system for defining a viewport. Inside of a viewport, the coordinates start with point $(0, 0)$ in the center of the viewport. The lower-left corner is $(-1, -1)$ while the upper-right is $(1, 1)$ (see Figure 18-15).

If a coordinate outside of the viewport is used for a drawing operation then the drawing is clipped along the viewport. For instance, attempting to draw a shape with a vertex at $(1, 2)$ will result in a shape that is cut off on the right side of the viewport.

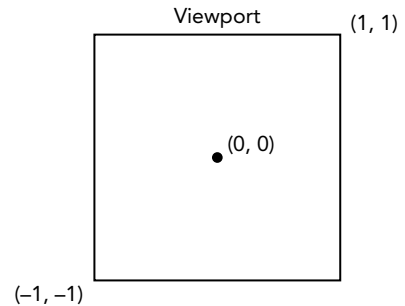

FIGURE 18-15:

Buffers

Vertex information is stored in typed arrays in JavaScript and must be converted into WebGL buffers for use. Buffers are created by calling `gl.createBuffer()` and then bound to the WebGL context using `gl.bindBuffer()`. Once that happens, you can fill the buffer with data. For example:

```
let buffer = gl.createBuffer();
gl.bindBuffer(gl.ARRAY_BUFFER, buffer);
gl.bufferData(gl.ARRAY_BUFFER, new Float32Array([0, 0.5, 1]), gl.STATIC_DRAW);
```

The call to `gl.bindBuffer()` sets `buffer` as the current buffer for the context. After that point, all buffer operations are performed on `buffer` directly. So the call to `gl.bufferData()` doesn't contain a direct reference to `buffer` but works on it nonetheless. That last line initializes `buffer` with information from a `Float32Array` (you generally will be using `Float32Array` for all vertex information). You can also use `gl.ELEMENT_ARRAY_BUFFER` if you intend to use `drawElements()` for outputting the buffer content.

The last argument of `gl.bufferData()` indicates how the buffer will be used. This is one of the following constants:

- `gl.STATIC_DRAW`—The data will be loaded once and used for drawing multiple times.
- `gl.STREAM_DRAW`—The data will be loaded once and used for drawing just a few times.
- `gl.DYNAMIC_DRAW`—The data will be modified repeatedly and used for drawing multiple times.

You'll likely use `gl.STATIC_DRAW` for most buffers unless you're an experienced OpenGL programmer.

Buffers stay in memory until the containing page is unloaded. If you no longer need a buffer, then it's best to free its memory by calling `gl.deleteBuffer()`:

```
gl.deleteBuffer(buffer);
```

Errors

One of the differences between most JavaScript and WebGL is that errors are generally not thrown from WebGL operations. Instead, you must call the `gl.getError()` method after invoking a method that may have failed. This method returns a constant value indicating the type of error that has occurred. The constants are as follows:

- `gl.NO_ERROR`—There wasn't an error during the last operation (value of 0).
- `gl.INVALID_ENUM`—An incorrect argument was passed to a method that was expecting one of the WebGL constants.
- `gl.INVALID_VALUE`—A negative number was passed where only an unsigned number is accepted.
- `gl.INVALID_OPERATION`—The operation cannot be completed in the current state.
- `gl.OUT_OF_MEMORY`—There is not enough memory to complete the operation.
- `gl.CONTEXT_LOST_WEBGL`—The WebGL context was lost because of an external event (such as loss of power on a device).

Each call to `gl.getError()` returns a single error value. After the initial call, the next call to `gl.getError()` may return another error value. If there are multiple errors, then this process continues until `gl.getError()` returns `gl.NO_ERROR`. If you have performed a number of operations, then you'll likely want to call `getError()` in a loop, such as:

```
let errorCode = gl.getError();
while (errorCode) {
  console.log("Error occurred: " + errorCode);
  errorCode = gl.getError();
}
```

If your WebGL script is not resulting in the correct output, then putting a few calls to `gl.getError()` into your script may help debug the issue.

Shaders

Shaders are another concept from OpenGL. There are two types of shaders in WebGL: *vertex shaders* and *fragment shaders*. Vertex shaders are used to convert a 3D vertex into a 2D point to be rendered. Fragment shaders are used to compute the correct color for drawing a single pixel. The unique and challenging aspect of WebGL shaders is that they are not written in JavaScript. Shaders are written using *OpenGL Shading Language (GLSL)*, a completely separate language from C or JavaScript.

Writing Shaders

GLSL is a C-like language that is used specifically for defining OpenGL shaders. Because WebGL is an implementation of OpenGL ES 2, the shaders used in OpenGL can be used directly in WebGL, allowing for easy porting of desktop graphics to the Web.

Each shader has a method called `main()` that is executed repeatedly during drawing. There are two ways to pass data into a shader: *attributes* and *uniforms*. Attributes are used to pass vertices into a vertex shader while uniforms are used to pass constant values to either type of shader. Attributes and uniforms are defined outside of `main()` by using the keywords `attribute` or `uniform`, respectively. After the value type keyword, the data type is specified followed by a name. Here's a simple example vertex shader:

```
// OpenGL Shading Language
// Shader by Bartek Drozd in his article at
// http:// www.netmagazine.com/tutorials/get-started-webgl-draw-square
attribute vec2 aVertexPosition;

void main() {
    gl_Position = vec4(aVertexPosition, 0.0, 1.0);
}
```

This vertex shader defines a single attribute called `aVertexPosition`. This attribute is an array of two items (`vec2` data type) representing an x- and y-coordinate. A vertex shader must always result in a four-part vertex being assigned to the special variable `gl_Position` even though only two coordinates were passed. This shader creates a new four-item array (`vec4`) and fills in the missing coordinates, effectively turning a 2D coordinate into a 3D one.

Fragment shaders are similar to vertex shaders except you can pass data only in via uniforms. Here's an example fragment shader:

```
// OpenGL Shading Language
// Shader by Bartek Drozd in his article at
// http:// www.netmagazine.com/tutorials/get-started-webgl-draw-square
uniform vec4 uColor;

void main() {
    gl_FragColor = uColor;
}
```

Fragment shaders must result in a value being assigned to `gl_FragColor`, which indicates the color to use while drawing. This shader defined a uniform four-part (`vec4`) color named `uColor` to be set. Literally, this shader does nothing but assign the passed-in value to `gl_FragColor`. The value of `uColor` cannot be changed within the shader.

NOTE *OpenGL Shading Language is a more complex language than represented here. There are entire books devoted to explaining the intricacies of the languages, and so this section is just a quick introduction to the language as a way of facilitating WebGL usage. For more information, please read OpenGL Shading Language by Randi J. Rost (Addison-Wesley, 2006).*

Creating Shader Programs

GLSL cannot be natively understood by a browser, so you must have a string of GLSL ready for compilation and linking into a shader program. For ease of use, shaders are typically included in a page using `<script>` elements with a custom `type` attribute. Using an invalid `type` attribute prevents

the browser from attempting to interpret the `<script>` contents while allowing you easy access. For example:

```
<script type="x-webgl/x-vertex-shader" id="vertexShader">
attribute vec2 aVertexPosition;

void main() {
    gl_Position = vec4(aVertexPosition, 0.0, 1.0);
}
</script>
<script type="x-webgl/x-fragment-shader" id="fragmentShader">
uniform vec4 uColor;

void main() {
    gl_FragColor = uColor;
}
</script>
```

You can then extract the contents of the `<script>` element using the `text` property:

```
let vertexGls1 = document.getElementById("vertexShader").text;
    fragmentGls1 = document.getElementById("fragmentShader").text;
```

More complex WebGL applications may choose to download shaders dynamically. The important aspect is that you need a GLSL string in order to use a shader.

Once you have a GLSL string, the next step is to create a shader object. This is done by calling the `gl.createShader()` method and passing in the type of shader to create (`gl.VERTEX_SHADER` or `gl.FRAGMENT_SHADER`). After that, the source code of the shader is applied using `gl.shaderSource()` and the shader is compiled using `gl.compileShader()`. Here's an example:

```
let vertexShader = gl.createShader(gl.VERTEX_SHADER);
gl.shaderSource(vertexShader, vertexGls1);
gl.compileShader(vertexShader);
let fragmentShader = gl.createShader(gl.FRAGMENT_SHADER);
gl.shaderSource(fragmentShader, fragmentGls1);
gl.compileShader(fragmentShader);
```

This code creates two shaders and stores them in `vertexShader` and `fragmentShader`. These two objects can then be linked into a shader program by using the following code:

```
let program = gl.createProgram();
gl.attachShader(program, vertexShader);
gl.attachShader(program, fragmentShader);
gl.linkProgram(program);
```

The first line creates a program and then `attachShader()` is used to include the two shaders. The call to `gl.linkProgram()` encapsulates both shaders together into the variable `program`. With the program linked, you can instruct the WebGL context to use the program via the `gl.useProgram()` method:

```
gl.useProgram(program);
```

After `gl.useProgram()` has been called, all further drawing operations will use the specified program.

Passing Values to Shaders

Each of the previously defined shaders has a value that must be passed in to complete the shader's job. To pass values into a shader, you must first locate the variable whose value must be filled. For uniform variables, this is done through `gl.getUniformLocation()`, which returns an object representing the location of the uniform variable in memory. You can then use this location to assign data. For example:

```
let uColor = gl.getUniformLocation(program, "uColor");
gl.uniform4fv(uColor, [0, 0, 0, 1]);
```

This example locates the uniform variable `uColor` in `program` and returns its memory location. The second line assigns a value into `uColor` using `gl.uniform4fv()`.

A similar process is followed for attribute variables in vertex shaders. To get the location of an attribute variable, use `gl.getAttribLocation()`. Once the location is retrieved, it can be used as in this example:

```
let aVertexPosition = gl.getAttribLocation(program, "aVertexPosition");
gl.enableVertexAttribArray(aVertexPosition);
gl.vertexAttribPointer(aVertexPosition, itemSize, gl.FLOAT, false, 0, 0);
```

Here, the location of `aVertexPosition` is retrieved so that it may be enabled for use via `gl.enableVertexAttribArray()`. The last line creates a pointer into the last buffer specified using `gl.bindBuffer()` and stores it in `aVertexPosition` so that it may be used by the vertex shader.

Debugging Shaders and Programs

As with other operations in WebGL, shader operations may fail and will do so silently. You need to manually ask the WebGL context for information about the shader or program if you think there has been an error.

For shaders, call `gl.getShaderParameter()` to get the compiled status of the shader after attempting compilation:

```
if (!gl.getShaderParameter(vertexShader, gl.COMPILE_STATUS)) {
  alert(gl.getShaderInfoLog(vertexShader));
}
```

This example checks the compilation status of `vertexShader`. If the shader compiled successfully, then the call to `gl.getShaderParameter()` returns `true`. If the call returns `false`, then there was an error during compilation and you can retrieve the error by using `gl.getShaderInfoLog()` and passing in the shader. This method returns a string message indicating the issue. Both `gl.getShaderParameter()` and `gl.getShaderInfoLog()` may be used on vertex shaders and fragment shaders.

Programs may also fail and have a similar method, `gl.getProgramParameter()`, to check status. The most common program failure is during the linking process, for which you would check using the following code:

```
if (!gl.getProgramParameter(program, gl.LINK_STATUS)) {
  alert(gl.getProgramInfoLog(program));
}
```

As with `gl.getShaderParameter()`, the `gl.getProgramParameter()` returns either `true` to indicate that the link succeeded or `false` to indicate it failed. There is also `gl.getProgramInfoLog()`, which is used to get information about the program during failures.

These methods are primarily used during development to aid in debugging. As long as there are no external dependencies, it's safe to remove them in production.

Upgrading from GLSL 100 to GLSL 300

One of the primary changes in WebGL2 is the upgrade to the GLSL 3.00 ES shaders. This upgrade exposes a wide range of new shader features such as 3D textures, which are available on devices that support OpenGL ES 3.0. To use the upgraded shader version, the first line of the shaders must be the following:

```
#version 300 es
```

This upgrade requires a few syntactical changes:

- Vertex attribute variables are declared using the `in` keyword instead of `attribute`.
- Variables using the `varying` keyword for things like vertex or fragment shaders now must use `in` or `out` depending on their behavior with respect to the shader.
- The `gl_FragColor` predefined output variable no longer exists; fragment shaders must declare their own `out` variable for the color output.
- Texture lookup functions such as `texture2D` and `textureCube` have been unified into a single `texture` function.

Drawing

WebGL can draw only three types of shapes: points, lines, and triangles. All other shapes must be composed using a combination of these three basic shapes drawn in three-dimensional space. Drawing is executed by using the `drawArrays()` or `drawElements()` methods; the former works on array buffers while the latter acts on element array buffers.

The first argument for both `gl.drawArrays()` and `drawElements()` is a constant indicating the type of shape to draw. The constants are:

- `gl.POINTS`—Treats each vertex as a single point to be drawn.
- `gl.LINES`—Treats the array as a series of vertices between which to draw lines. Each set of vertices is a start point and an end point, so you must have an even number of vertices in the array for all drawing to take place.
- `gl.LINE_LOOP`—Treats the array as a series of vertices between which to draw lines. The line is drawn from the first vertex to the second, from the second to the third, and so on until the last vertex is reached. A line is then drawn from the last vertex to the first vertex. This effectively creates an outline of a shape.
- `gl.LINE_STRIP`—Same as `gl.LINE_LOOP` except a line is not drawn from the last vertex back to the first.
- `gl.TRIANGLES`—Treats the array as a series of vertices within which triangles should be drawn. Each triangle is drawn separately from the previous without sharing vertices unless explicitly specified.
- `gl.TRIANGLES_STRIP`—Same as `gl.TRIANGLES` except vertices after the first three are treated as the third vertex for a new triangle made with the previous two vertices. For

example, if an array contains vertices A, B, C, D, the first triangle is drawn as ABC while the second is drawn as BCD.

- `gl.TRIANGLES_FAN`—Same as `gl.TRIANGLES` except vertices after the first three are treated as the third vertex for a triangle made with the previous vertex and the first coordinate. For example, if an array contains vertices A, B, C, D, the first triangle is drawn as ABC while the second is drawn as ACD.

The `gl.drawArrays()` method accepts one of these values as its first argument, the starting index within the array buffer as the second argument, and the number of sets contained in the array buffer as the third argument. The following code uses `gl.drawArrays()` to draw a single triangle across the canvas:

```
// assume viewport is cleared using the shaders from earlier in the section
// define three vertices, x and y for each
let vertices = new Float32Array([ 0, 1, 1, -1, -1, -1 ]),
    buffer = gl.createBuffer(),
    vertexSetSize = 2,
    vertexSetCount = vertices.length/vertexSetSize,
    uColor,
    aVertexPosition;
// put data into the buffer
gl.bindBuffer(gl.ARRAY_BUFFER, buffer);
gl.bufferData(gl.ARRAY_BUFFER, vertices, gl.STATIC_DRAW);
// pass color to fragment shader
uColor = gl.getUniformLocation(program, "uColor");
gl.uniform4fv(uColor, [ 0, 0, 0, 1 ]);
// pass vertex information to shader
aVertexPosition = gl.getAttribLocation(program, "aVertexPosition");
gl.enableVertexAttribArray(aVertexPosition);
gl.vertexAttribPointer(aVertexPosition, vertexSetSize, gl.FLOAT, false, 0, 0);
// draw the triangle
gl.drawArrays(gl.TRIANGLES, 0, vertexSetCount);
```

This example defines a `Float32Array` containing three sets of two-point vertices. It's important to keep track of the size and number of vertex sets for use in later calculations. The `vertexSetSize` is set to 2 while the `vertexSetCount` is calculated. The vertex information is stored in a buffer. Color information is then passed to the fragment shader.

The vertex shader is passed the size of the vertex set and indicates that the vertex coordinates are floats (`gl.FLOAT`). The fourth argument is a Boolean indicating that the coordinates are not normalized. The fifth argument is the *stride value*, which indicates how many array items need to be skipped to get the next value. This is 0 unless you really know what you're doing. The last argument is the starting offset, which is 0 to start at the first item.

The last step is to draw the triangle by using `gl.drawArrays()`. By specifying the first argument as `gl.TRIANGLES`, a triangle will be drawn from (0, 1) to (1, -1) to (-1, -1) and filled with the color passed to the fragment shader. The second argument is the starting offset in the buffer, and the last argument is the total number of vertex sets to read. The result of this drawing operation is displayed in Figure 18-16.

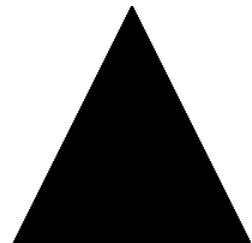

FIGURE 18-16:

By changing the first argument to `gl.drawArrays()`, you can change how the triangle is drawn. Figure 18-17 shows some other possible outputs based on changing the first argument.

Textures

WebGL textures work together with images from the DOM. You create a new texture using `gl.createTexture()` and then bind an image to that texture. If the image isn't already loaded, then you may create a new instance of `Image` to dynamically load it. A texture isn't initialized until the image is completely loaded, so texture setup steps must be done after the `load` event has fired. For example:

```
let image = new Image(),
    texture;
image.src = "smile.gif";
image.onload = function() {
  texture = gl.createTexture();
  gl.bindTexture(gl.TEXTURE_2D, texture);
  gl.pixelStorei(gl.UNPACK_FLIP_Y_WEBGL, true);

  gl.texImage2D(gl.TEXTURE_2D, 0, gl.RGBA, gl.RGBA, gl.UNSIGNED_BYTE, image);
  gl.texParameteri(gl.TEXTURE_2D, gl.TEXTURE_MAG_FILTER, gl.NEAREST);
  gl.texParameteri(gl.TEXTURE_2D, gl.TEXTURE_MIN_FILTER, gl.NEAREST);

  // clear current texture
  gl.bindTexture(gl.TEXTURE_2D, null);
}
```

Aside from using a DOM image, these steps are the same for creating texture in OpenGL. The biggest difference is in setting the pixel storage format with `gl.pixelStorei()`. The constant `gl.UNPACK_FLIP_Y_WEBGL` is unique to WebGL and must be used in most circumstances when loading web-based images. This is because of the different coordinate systems used by GIF, JPEG, and PNG images as compared to the internal coordinate system of WebGL. Without this flag, the image is interpreted upside down.

Images used for textures must be of the same origin as the containing page or else exist on servers that have Cross-Origin Resource Sharing (CORS) enabled for the images.

NOTE *Texture sources may be images, videos loaded into the `<video>` element, and even another `<canvas>` element. The same restrictions regarding cross-origin resources apply to videos.*

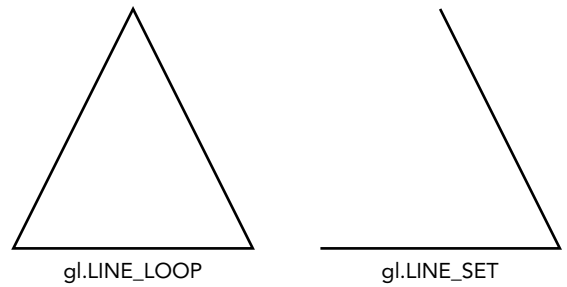

FIGURE 18-17:

Reading Pixels

As with the 2D context, it's possible to read pixels from the WebGL context. The `readPixels()` method has the same arguments as in OpenGL with the exception that the last argument must be a typed array. Pixel information is read from the frame buffer and placed into the typed array. The

arguments for `readPixels()` are `x`, `y`, `width`, `height`, `image format`, `type`, and `typed array`. The first four arguments specify the location of the pixels to read. The image format argument will almost always be `gl.RGBA`. The type argument is the type of data that will be stored in the typed array and has the following restrictions:

- If the type is `gl.UNSIGNED_BYTE`, then the typed array must be `Uint8Array`.
- If the type is `gl.UNSIGNED_SHORT_5_6_5`, `gl.UNSIGNED_SHORT_4_4_4_4`, or `gl.UNSIGNED_SHORT_5_5_5_1`, then the typed array must be `Uint16Array`.

Here's a simple example:

```
let pixels = new Uint8Array(25*25);
gl.readPixels(0, 0, 25, 25, gl.RGBA, gl.UNSIGNED_BYTE, pixels);
```

This code reads a 25×25 area of the frame buffer and stores the pixel information in the `pixels` array. Each pixel color is represented as four array items, one each for red, green, blue, and alpha. The values are numbers 0 through 255, inclusive. Don't forget to initialize the typed array for the amount of data you're expecting back.

Calling `readPixels()` before the browser has drawn the updated WebGL image works as expected. After the paint has occurred, the frame buffer is reverted to its original cleared state and calling `readPixels()` will result in pixel data matching the cleared state. If you want to read pixels after the paint has occurred, then you must initialize the WebGL context with the `preserveDrawingBuffer` option discussed previously:

```
let gl = drawing.getContext("webgl", { preserveDrawingBuffer: true; });
```

Setting this flag forces the frame buffer to stay in its last state until the next draw occurs. This option does have some performance overhead, so it's best to avoid using if possible.

WebGL1 versus WebGL2

Code written for WebGL1 is nearly 100 percent compatible with WebGL2. When using the `webgl2` context, the only code modification that is needed to ensure compatibility is treatment of extensions. In WebGL2, many extensions have become default features.

For example, to use draw buffers in WebGL1, you would test for the extension before use, as follows:

```
let ext = gl.getExtension('WEBGL_draw_buffers');

if (!ext) {
  // handle missing extension
} else {
  ext.drawBuffersWEBGL([...])
}
```

In WebGL2, this is no longer required, as the feature is available directly as a context object method:

```
gl.drawBuffers([...]);
```

The following have all become standard features:

- `ANGLE_instanced_arrays`
- `EXT_blend_minmax`
- `EXT_frag_depth`
- `EXT_shader_texture_lod`
- `OES_element_index_uint`
- `OES_standard_derivatives`
- `OES_texture_float`
- `OES_texture_float_linear`
- `OES_vertex_array_object`
- `WEBGL_depth_texture`
- `WEBGL_draw_buffers`
- Vertex shader texture access

NOTE *There is an excellent post covering the basics of the WebGL upgrade, which can be found at <https://webgl2fundamentals.org/webgl/lessons/webgl1-to-webgl2.html>.*

SUMMARY

The `requestAnimationFrame` is a simple but elegant tool that allows JavaScript to tap into the rendering cycle of the browser in order to efficiently perform visual manipulation of the page.

The HTML5 `<canvas>` element provides a JavaScript API for creating graphics on the fly. Graphics are created in a specific context, of which there are currently two. The first is a 2D context that allows primitive drawing operations:

- Setting fill and stroke colors and patterns
- Drawing rectangles
- Drawing paths
- Drawing text
- Creating gradients and patterns

The second is a 3D context called WebGL. WebGL is a browser port of OpenGL ES 2.0, a language frequently used by game developers for computer graphics. WebGL allows far more powerful graphics processing than the 2D context, providing:

- Vertex and fragment shaders written in OpenGL Shading Language (GLSL)
- Typed array support, limiting the type of data contained in an array to specific numeric types
- Texture creation and manipulation

The `<canvas>` tag itself is now widely supported and is available in the most recent version of all major browsers.

19

Scripting Forms

WHAT'S IN THIS CHAPTER?

- Understanding form basics
- Text box validation and interaction
- Working with other form controls

WROX.COM DOWNLOADS FOR THIS CHAPTER

Please note that all the code examples for this chapter are available as a part of this chapter's code download on the book's website at www.wrox.com/go/projavascript4e on the Download Code tab.

One of the original uses of JavaScript was to offload some form-processing responsibilities onto the browser instead of relying on the server to do it all. Although the web and JavaScript have evolved since that time, web forms remain more or less unchanged. The failure of web forms to provide out-of-the-box solutions for common problems led developers to use JavaScript not just for form validation but also to augment the default behavior of standard form controls.

FORM BASICS

Web forms are represented by the `<form>` element in HTML and by the `HTMLFormElement` type in JavaScript. The `HTMLFormElement` type inherits from `HTMLElement` and therefore has all of the same default properties as other HTML elements. However, `HTMLFormElement` also has the following additional properties and methods:

- `acceptCharset`—The character sets that the server can process; equivalent to the HTML `accept-charset` attribute.

- `action`—The URL to send the request to; equivalent to the HTML `action` attribute.
- `elements`—An `HTMLCollection` of all controls in the form.
- `enctype`—The encoding type of the request; equivalent to the HTML `enctype` attribute.
- `length`—The number of controls in the form.
- `method`—The type of HTTP request to send, typically "get" or "post"; equivalent to the HTML `method` attribute.
- `name`—The name of the form; equivalent to the HTML `name` attribute.
- `reset()`—Resets all form fields to their default values.
- `submit()`—Submits the form.
- `target`—The name of the window to use for sending the request and receiving the response; equivalent to the HTML `target` attribute.

References to `<form>` elements can be retrieved in a number of different ways. The most common way is to treat them as any other elements and assign the `id` attribute, allowing the use of `getElementById()`, as in the following example:

```
let form = document.getElementById("form1");
```

All forms on the page can also be retrieved from `document.forms` collection. Each form can be accessed in this collection by numeric index and by name, as shown in the following examples:

```
// get the first form in the page
let firstForm = document.forms[0];

// get the form with a name of "form2"
let myForm = document.forms["form2"];
```

Older browsers, or those with strict backwards compatibility, also add each form with a name as a property of the `document` object. For instance, a form named "form2" could be accessed via `document.form2`. This approach is not recommended, because it is error-prone and may be removed from browsers in the future.

Note that forms can have both an `id` and a `name` and that these values need not be the same.

Submitting Forms

Forms are submitted when a user interacts with a submit button or an image button. Submit buttons are defined using either the `<input>` element or the `<button>` element with a `type` attribute of "submit", and image buttons are defined using the `<input>` element with a `type` attribute of "image". All of the following, when clicked, will submit a form in which the button resides:

```
<!-- generic submit button -->
<input type="submit" value="Submit Form">

<!-- custom submit button -->
<button type="submit">Submit Form</button>
```

```
<!-- image button -->
<input type="image" src="graphic.gif">
```

If any one of these types of buttons is within a form that has a submit button, pressing Enter on the keyboard while a form control has focus will also submit the form. (The one exception is a `textarea`, within which Enter creates a new line of text.) Note that forms without a submit button will not be submitted when Enter is pressed.

When a form is submitted in this manner, the `submit` event fires right before the request is sent to the server. This gives you the opportunity to validate the form data and decide whether to allow the form submission to occur. Preventing the event's default behavior cancels the form submission. For example, the following prevents a form from being submitted:

```
let form = document.getElementById("myForm");

form.addEventListener("submit", (event) => {
  // prevent form submission
  event.preventDefault();
});
```

The `preventDefault()` method stops the form from being submitted. Typically, this functionality is used when data in the form is invalid and should not be sent to the server.

It's possible to submit a form programmatically by calling the `submit()` method from JavaScript. This method can be called at any time to submit a form and does not require a submit button to be present in the form to function appropriately. Here's an example:

```
let form = document.getElementById("myForm");

// submit the form
form.submit();
```

When a form is submitted via `submit()`, the `submit` event does not fire, so be sure to do data validation before calling the method.

One of the biggest issues with form submission is the possibility of submitting the form twice. Users sometimes get impatient when it seems like nothing is happening and may click a submit button multiple times. The results can be annoying (because the server processes duplicate requests) or damaging (if the user is attempting a purchase and ends up placing multiple orders). There are essentially two ways to solve this problem: disable the submit button once the form is submitted, or use the `onsubmit` event handler to cancel any further form submissions.

Resetting Forms

Forms are reset when the user clicks a reset button. Reset buttons are created using either the `<input>` or the `<button>` element with a `type` attribute of `"reset"`, as in these examples:

```
<!-- generic reset button -->
<input type="reset" value="Reset Form">

<!-- custom reset button -->
<button type="reset">Reset Form</button>
```

Either of these buttons will reset a form. When a form is reset, all of the form fields are set back to the values they had when the page was first rendered. If a field was originally blank, it becomes blank again, whereas a field with a default value reverts to that value.

When a form is reset by the user clicking a reset button, the `reset` event fires. This event gives you the opportunity to cancel the reset if necessary. For example, the following prevents a form from being reset:

```
let form = document.getElementById("myForm");

form.addEventListener("reset", (event) => {
  event.preventDefault();
});
```

As with form submission, resetting a form can be accomplished via JavaScript using the `reset()` method, as in this example:

```
let form = document.getElementById("myForm");

// reset the form
form.reset();
```

Unlike the `submit()` method's functionality, `reset()` fires the `reset` event the same as if a reset button were clicked.

NOTE *Form resetting is typically a frowned-upon approach to web form design. It's often disorienting to the user and, when triggered accidentally, can be quite frustrating. There's almost never a need to reset a form. It's often enough to provide a cancel button that takes the user back to the previous page rather than explicitly revert all values in the form.*

Form Fields

Form elements can be accessed in the same ways as any other elements on the page using native DOM methods. Additionally, all form elements are parts of an `elements` collection that is a property of each form. The `elements` collection is an ordered list of references to all form fields in the form and includes all `<input>`, `<textarea>`, `<button>`, `<select>`, and `<fieldset>` elements. Each form field appears in the `elements` collection in the order in which it appears in the markup, indexed by both position and name. Here are some examples:

```
let form = document.getElementById("form1");

// get the first field in the form
let field1 = form.elements[0];

// get the field named "textbox1"
let field2 = form.elements["textbox1"];

// get the number of fields
let fieldCount = form.elements.length;
```

If a name is in use by multiple form controls, as is the case with radio buttons, then an `HTMLCollection` is returned containing all of the elements with the name. For example, consider the following HTML snippet:

```
<form method="post" id="myForm">
  <ul>
    <li><input type="radio" name="color" value="red">Red</li>
    <li><input type="radio" name="color" value="green">Green</li>
    <li><input type="radio" name="color" value="blue">Blue</li>
  </ul>
</form>
```

The form in this HTML has three radio controls that have "color" as their name, which ties the fields together. When accessing `elements["color"]`, a `NodeList` is returned, containing all three elements; when accessing `elements[0]`, however, only the first element is returned. Consider this example:

```
let form = document.getElementById("myForm");

let colorFields = form.elements["color"];
console.log(colorFields.length); // 3

let firstColorField = colorFields[0];
let firstFormField = form.elements[0];
console.log(firstColorField === firstFormField); // true
```

This code shows that the first form field, accessed via `form.elements[0]`, is the same as the first element contained in `form.elements["color"]`.

NOTE *It's possible to access elements as properties of a form as well, such as `form[0]` to get the first form field and `form["color"]` to get a named field. These properties always return the same thing as their equivalent in the `elements` collection. This approach is provided for backwards compatibility with older browsers and should be avoided when possible in favor of using `elements`.*

Common Form-Field Properties

With the exception of the `<fieldset>` element, all form fields share a common set of properties. Because the `<input>` type represents many form fields, some properties are used only with certain field types, whereas others are used regardless of the field type. The common form-field properties and methods are as follows:

- `disabled`—A Boolean indicating if the field is disabled.
- `form`—A pointer to the form that the field belongs to. This property is read-only.
- `name`—The name of the field.
- `readOnly`—A Boolean indicating if the field is read-only.
- `tabIndex`—Indicates the tab order for the field.

- `type`—The type of the field: "checkbox", "radio", and so on.
- `value`—The value of the field that will be submitted to the server. For file-input fields, this property is read only and simply contains the file's path on the computer.

With the exception of the `form` property, JavaScript can change all other properties dynamically. Consider this example:

```
let form = document.getElementById("myForm");
let field = form.elements[0];

// change the value
field.value = "Another value";

// check the value of form
console.log(field.form === form); // true

// set focus to the field
field.focus();

// disable the field
field.disabled = true;

// change the type of field (not recommended, but possible for <input>)
field.type = "checkbox";
```

The ability to change form-field properties dynamically allows you to change the form at any time and in almost any way. For example, a common problem with web forms is users' tendency to click the submit button twice. This is a major problem when credit-card orders are involved because it may result in duplicate charges. A very common solution to this problem is to disable the submit button once it's been clicked, which is possible by listening for the `submit` event and disabling the submit button when it occurs. The following code accomplishes this:

```
// Code to prevent multiple form submissions
let form = document.getElementById("myForm");

form.addEventListener("submit", (event) => {
  let target = event.target;

  // get the submit button
  let btn = target.elements["submit-btn"];

  // disable the submit button
  btn.disabled = true;
});
```

This code attaches an event handler on the form for the `submit` event. When the event fires, the submit button is retrieved and its `disabled` property is set to `true`. Note that you cannot attach an `onclick` event handler to the submit button to do this because of a timing issue across browsers: some browsers fire the `click` event before the form's `submit` event, some after. For browsers that fire `click` first, the button will be disabled before the submission occurs, meaning that the form will never be submitted. Therefore it's better to disable the submit button using the `submit` event. This approach won't work if you are submitting the form without using a submit button because, as stated before, the `submit` event is fired only by a submit button.

The `type` property exists for all form fields except `<fieldset>`. For `<input>` elements, this value is equal to the HTML `type` attribute. For other elements, the value of `type` is set as described in the following table.

DESCRIPTION	SAMPLE HTML	VALUE OF TYPE
Single-select list	<code><select>...</select></code>	"select-one"
Multi-select list	<code><select multiple>...</select></code>	"select-multiple"
Custom button	<code><button>...</button></code>	"submit"
Custom nonsubmit button	<code><button type="button">...</button></code>	"button"
Custom reset button	<code><button type="reset">...</button></code>	"reset"
Custom submit button	<code><button type="submit">...</button></code>	"submit"

For `<input>` and `<button>` elements, the `type` property can be changed dynamically, whereas the `<select>` element's `type` property is read-only.

Common Form-Field Methods

Each form field has two methods in common: `focus()` and `blur()`. The `focus()` method sets the browser's focus to the form field, meaning that the field becomes active and will respond to keyboard events. For example, a text box that receives focus displays its caret and is ready to accept input. The `focus()` method is most often employed to call the user's attention to some part of the page. It's quite common, for instance, to have the focus moved to the first field in a form when the page is loaded. This can be accomplished by listening for the `load` event and then calling `focus()` on the first field, as in the following example:

```

window.addEventListener("load", (event) => {
  document.forms[0].elements[0].focus();
});

```

Note that this code will cause an error if the first form field is an `<input>` element with a `type` of "hidden" or if the field is being hidden using the `display` or `visibility` CSS property.

HTML5 introduces an `autofocus` attribute for form fields that causes supporting browsers to automatically set the focus to that element without the use of JavaScript. For example:

```
<input type="text" autofocus>
```

In order for the previous code to work correctly with `autofocus`, you must first detect if it has been set. If `autofocus` is set, you should not call `focus()`:

```

window.addEventListener("load", (event) => {
  let element = document.forms[0].elements[0];

  if (element.autofocus !== true) {
    element.focus();
    console.log("JS focus");
  }
});

```

Because `autofocus` is a Boolean attribute, the value of the `autofocus` property will be `true` in supporting browsers. (It will be the empty string in browsers without support.) So this code calls `focus()` only if the `autofocus` property is not equal to `true`, ensuring forwards compatibility. The `autofocus` property is supported in most modern browsers. It only lacks support in iOS Safari, Opera Mini, and Internet Explorer 10 and below.

NOTE *By default, only form elements can have focus set to them. It's possible to allow any element to have focus by setting its `tabIndex` property to `-1` and then calling `focus()`. The only browser that doesn't support this technique is Opera.*

The opposite of `focus()` is `blur()`, which removes focus from the element. When `blur()` is called, focus isn't moved to any element in particular; it's just removed from the field on which it was called. This method was used early in web development to create read-only fields before the `readonly` attribute was introduced. There's rarely a need to call `blur()`, but it's available if necessary. Here's an example:

```
document.forms[0].elements[0].blur();
```

Common Form-Field Events

All form fields support the following three events in addition to mouse, keyboard, mutation, and HTML events:

- ▶ `blur`—Fires when the field loses focus.
- ▶ `change`—Fires when the field loses focus and the `value` has changed for `<input>` and `<textarea>` elements; also fires when the selected option changes for `<select>` elements.
- ▶ `focus`—Fires when the field gets focus.

Both the `blur` and the `focus` events fire because of users manually changing the field's focus, as well as by calling the `blur()` and `focus()` methods, respectively. These two events work the same way for all form fields. The `change` event, however, fires at different times for different controls. For `<input>` and `<textarea>` elements, the `change` event fires when the field loses focus and the `value` has changed since the time the control got focus. For `<select>` elements, however, the `change` event fires whenever the user changes the selected option; the control need not lose focus for `change` to fire.

The `focus` and `blur` events are typically used to change the user interface in some way, to provide either visual cues or additional functionality (such as showing a drop-down menu of options for a text box). The `change` event is typically used to validate data that was entered into a field. For example, consider a text box that expects only numbers to be entered. The `focus` event may be used to change the background color to more clearly indicate that the field has focus, the `blur` event can be used to remove that background color, and the `change` event can change the background color to red if nonnumeric characters are entered. The following code accomplishes this:

```
let textbox = document.forms[0].elements[0];
```

```

textbox.addEventListener("focus", (event) => {
  let target = event.target;
  if (target.style.backgroundColor !== "red") {
    target.style.backgroundColor = "yellow";
  }
});

textbox.addEventListener("blur", (event) => {
  let target = event.target;
  target.style.backgroundColor = /^[^d]/.test(target.value) ? "red" : "";
});

textbox.addEventListener("change", (event) => {
  let target = event.target;
  target.style.backgroundColor = /^[^d]/.test(target.value) ? "red" : "";
});

```

The `onfocus` event handler simply changes the background color of the text box to yellow, more clearly indicating that it's the active field. The `onblur` and `onchange` event handlers turn the background color red if any nonnumeric character is found. To test for a nonnumeric character, use a simple regular expression against the text box's `value`. This functionality has to be in both the `onblur` and `onchange` event handlers to ensure that the behavior remains consistent regardless of text box changes.

NOTE *The relationship between the `blur` and the `change` events is not strictly defined. In some browsers, the `blur` event fires before `change`; in others, it's the opposite. You can't depend on the order in which these events fire, so use care whenever they are required.*

SCRIPTING TEXT BOXES

There are two ways to represent text boxes in HTML: a single-line version using the `<input>` element and a multiline version using `<textarea>`. These two controls are very similar and behave in similar ways most of the time. There are, however, some important differences.

By default, the `<input>` element displays a text box, even when the `type` attribute is omitted (the default value is `"text"`). The `size` attribute can then be used to specify how wide the text box should be in terms of visible characters. The `value` attribute specifies the initial value of the text box, and the `maxlength` attribute specifies the maximum number of characters allowed in the text box. So to create a text box that can display 25 characters at a time but has a maximum length of 50, you can use the following code:

```
<input type="text" size="25" maxlength="50" value="initial value">
```

The `<textarea>` element always renders a multiline text box. To specify how large the text box should be, you can use the `rows` attribute, which specifies the height of the text box in number of characters, and the `cols` attribute, which specifies the width in number of characters, similar to `size`

for an `<input>` element. Unlike `<input>`, the initial value of a `<textarea>` must be enclosed between `<textarea>` and `</textarea>`, as shown here:

```
<textarea rows="25" cols="5">initial value</textarea>
```

Also unlike the `<input>` element, a `<textarea>` cannot specify the maximum number of characters allowed using HTML.

Despite the differences in markup, both types of text boxes store their contents in the `value` property. The value can be used to read the text box value and to set the text box value, as in this example:

```
let textbox = document.forms[0].elements["textbox1"];
console.log(textbox.value);

textbox.value = "Some new value";
```

You should use the `value` property to read or write text box values rather than to use standard DOM methods. For instance, don't use `setAttribute()` to set the `value` attribute on an `<input>` element, and don't try to modify the first child node of a `<textarea>` element. Changes to the `value` property aren't always reflected in the DOM either, so it's best to avoid using DOM methods when dealing with text box values.

Text Selection

Both types of text boxes support a method called `select()`, which selects all of the text in a text box. Most browsers automatically set focus to the text box when the `select()` method is called (Opera does not). The method accepts no arguments and can be called at any time. Here's an example:

```
let textbox = document.forms[0].elements["textbox1"];
textbox.select();
```

It's quite common to select all of the text in a text box when it gets focus, especially if the text box has a default value. The thinking is that it makes life easier for users when they don't have to delete text separately. This pattern is accomplished with the following code:

```
textbox.addEventListener("focus", (event) => {
  event.target.select();
});
```

With this code applied to a text box, all of the text will be selected as soon as the text box gets focus. This can greatly aid the usability of forms.

The select Event

To accompany the `select()` method, there is a `select` event. The `select` event fires when text is selected in the text box. Exactly when the event fires differs from browser to browser. In Internet Explorer 9+, Opera, Firefox, Chrome, and Safari, the `select` event fires once the user has finished selecting text, whereas in Internet Explorer 8 and earlier it fires as soon as one letter is selected. The `select` event also fires when the `select()` method is called. Here's a simple example:

```
let textbox = document.forms[0].elements["textbox1"];

textbox.addEventListener("select", (event) => {
  console.log('Text selected: ${textbox.value}');
});
```

Retrieving Selected Text

Although useful for understanding when text is selected, the `select` event provides no information about what text has been selected. HTML5 solved this issue by introducing some extensions to allow for better retrieval of selected text. The specification approach adds two properties to text boxes: `selectionStart` and `selectionEnd`. These properties contain zero-based numbers indicating the text-selection boundaries (the offset of the beginning of text selection and the offset of end of text selection, respectively). So, to get the selected text in a text box, you can use the following code:

```
function getSelectedText(textbox){
    return textbox.value.substring(textbox.selectionStart,
                                  textbox.selectionEnd);
}
```

Because the `substring()` method works on string offsets, the values from `selectionStart` and `selectionEnd` can be passed in directly to retrieve the selected text.

This solution works for Internet Explorer 9+, Firefox, Safari, Chrome, and Opera. Internet Explorer 8 and earlier don't support these properties, so a different approach is necessary.

Older versions of Internet Explorer have a `document.selection` object that contains text-selection information for the entire document, which means you can't be sure where the selected text is on the page. When used in conjunction with the `select` event, however, you can be assured that the selection is inside the text box that fired the event. To get the selected text, you must first create a range and then extract the text from it, as in the following:

```
function getSelectedText(textbox){
    if (typeof textbox.selectionStart == "number"){
        return textbox.value.substring(textbox.selectionStart,
                                       textbox.selectionEnd);
    } else if (document.selection){
        return document.selection.createRange().text;
    }
}
```

This function has been modified to determine whether to use the Internet Explorer approach to selected text. Note that `document.selection` doesn't need the `textbox` argument at all.

Partial Text Selection

HTML5 also specifies an addition to aid in partially selecting text in a text box. The `setSelectionRange()` method, originally implemented by Firefox, is now available on all text boxes in addition to the `select()` method. This method takes two arguments: the index of the first character to select and the index at which to stop the selection (the same as the string's `substring()` method). Here are some examples:

```
textbox.value = "Hello world!"

// select all text
textbox.setSelectionRange(0, textbox.value.length); // "Hello world!"

// select first three characters
textbox.setSelectionRange(0, 3); // "Hel"
```

```
// select characters 4 through 6
textbox.setSelectionRange(4, 7); // "o w"
```

To see the selection, you must set focus to the text box either immediately before or after a call to `setSelectionRange()`. This approach works for Internet Explorer 9, Firefox, Safari, Chrome, and Opera.

Internet Explorer 8 and earlier allow partial text selection through the use of ranges. To select part of the text in a text box, you must first create a range and place it in the correct position by using the `createTextRange()` method that Internet Explorer provides on text boxes and using the `moveStart()` and `moveEnd()` range methods to move the range into position. Before calling these methods, however, you need to collapse the range to the start of the text box using `collapse()`. After that, `moveStart()` moves both the starting and the end points of the range to the same position. You can then pass in the total number of characters to select as the argument to `moveEnd()`. The last step is to use the range's `select()` method to select the text, as shown in these examples:

```
textbox.value = "Hello world!";

var range = textbox.createTextRange();

// select all text
range.collapse(true);
range.moveStart("character", 0);
range.moveEnd("character", textbox.value.length); // "Hello world!"
range.select();

// select first three characters
range.collapse(true);
range.moveStart("character", 0);
range.moveEnd("character", 3);
range.select(); // "Hel"

// select characters 4 through 6
range.collapse(true);
range.moveStart("character", 4);
range.moveEnd("character", 3);
range.select(); // "o w"
```

As with the other browsers, the text box must have focus in order for the selection to be visible.

Partial text selection is useful for implementing advanced text input boxes such as those that provide autocomplete suggestions.

Input Filtering

It's common for text boxes to expect a certain type of data or data format. Perhaps the data needs to contain certain characters or must match a particular pattern. Because text boxes don't offer much in the way of validation by default, JavaScript must be used to accomplish such *input filtering*. Using a combination of events and other DOM capabilities, you can turn a regular text box into one that understands the data it is dealing with.

Blocking Characters

Certain types of input require that specific characters be present or absent. For example, a text box for the user's phone number should not allow non-numeric values to be inserted. The `keypress` event is responsible for inserting characters into a text box. Characters can be blocked by preventing this event's default behavior. For example, the following code blocks all key presses:

```
textbox.addEventListener("keypress", (event) => {
    event.preventDefault();
});
```

Running this code causes the text box to effectively become read only, because all key presses are blocked. To block only specific characters, you need to inspect the character code for the event and determine the correct response. For example, the following code allows only numbers:

```
textbox.addEventListener("keypress", (event) => {
    if (!/\d/.test(String.fromCharCode(event.charCode))) {
        event.preventDefault();
    }
});
```

In this example, the character code is converted to a string using `String.fromCharCode()`, and the result is tested against the regular expression `/\d/`, which matches all numeric characters. If that test fails, then the event is blocked using `preventDefault()`. This ensures that the text box ignores non-numeric keys.

Even though the `keypress` event should be fired only when a character key is pressed, some browsers fire it for other keys as well. Firefox and Safari (versions prior to 3.1) fire `keypress` for keys such as up, down, Backspace, and Delete; Safari versions 3.1 and later do not fire `keypress` events for these keys. This means that simply blocking all characters that aren't numbers isn't good enough because you'll also be blocking these very useful and necessary keys. Fortunately, you can easily detect when one of these keys is pressed. In Firefox, all noncharacter keys that fire the `keypress` event have a character code of 0, whereas Safari versions prior to 3 give them all a character code of 8. To generalize the case, you don't want to block any character codes lower than 10. The function can then be updated as follows:

```
textbox.addEventListener("keypress", (event) => {
    if (!/\d/.test(String.fromCharCode(event.charCode)) &&
        event.charCode > 9) {
        event.preventDefault();
    }
});
```

The event handler now behaves appropriately in all browsers, blocking nonnumeric characters but allowing all basic keys that also fire `keypress`.

There is still one more issue to handle: copying, pasting, and any other functions that involve the Ctrl key. In all browsers but Internet Explorer, the preceding code disallows the shortcut keystrokes of Ctrl+C, Ctrl+V, and any other combinations using the Ctrl key. The last check, therefore, is to make sure the Ctrl key is not pressed, as shown in the following example:

```
textbox.addEventListener("keypress", (event) => {
    if (!/\d/.test(String.fromCharCode(event.charCode)) &&
        event.charCode > 9 &&
```

```
    !event.ctrlKey) {  
        event.preventDefault();  
    }  
});
```

This final change ensures that all of the default text box behaviors work. This technique can be customized to allow or disallow any characters in a text box.

Dealing with the Clipboard

Internet Explorer was the first browser to support events related to the clipboard and access to clipboard data from JavaScript. The Internet Explorer implementation became a de facto standard as Safari, Chrome, Opera, and Firefox implemented similar events and clipboard access, and clipboard events were later added to HTML5. The following six events are related to the clipboard:

- `beforecopy`—Fires just before the copy operation takes place.
- `copy`—Fires when the copy operation takes place.
- `beforecut`—Fires just before the cut operation takes place.
- `cut`—Fires when the cut operation takes place.
- `beforepaste`—Fires just before the paste operation takes place.
- `paste`—Fires when the paste operation takes place.

Because this is a fairly new standard governing clipboard access, the behavior of the events and related objects differs from browser to browser. In Safari, Chrome, and Firefox, the `beforecopy`, `beforecut`, and `beforepaste` events fire only when the context menu for the text box is displayed (in anticipation of a clipboard event), but Internet Explorer fires them in that case and immediately before firing the `copy`, `cut`, and `paste` events. The `copy`, `cut`, and `paste` events all fire when you would expect them to in all browsers, both when the selection is made from a context menu and when using keyboard shortcuts.

The `beforecopy`, `beforecut`, and `beforepaste` events give you the opportunity to change the data being sent to or retrieved from the clipboard before the actual event occurs. However, canceling these events does not cancel the clipboard operation—you must cancel the `copy`, `cut`, or `paste` event to prevent the operation from occurring.

Clipboard data is accessible via the `clipboardData` object that exists either on the `window` object (in Internet Explorer) or on the `event` object (in Firefox, Safari, and Chrome). In Firefox, Safari, and Chrome, the `clipboardData` object is available only during clipboard events to prevent unauthorized clipboard access; Internet Explorer exposes the `clipboardData` object all the time. For cross-browser compatibility, it's best to use this object only during clipboard events.

There are three methods on the `clipboardData` object: `getData()`, `setData()`, and `clearData()`. The `getData()` method retrieves string data from the clipboard and accepts a single argument, which is the format for the data to retrieve. Internet Explorer specifies two options: "text" and "URL". Firefox, Safari, and Chrome expect a MIME type but will accept "text" as equivalent to "text/plain".

The `setData()` method is similar: its first argument is the data type, and its second argument is the text to place on the clipboard. Once again, Internet Explorer supports "text" and "URL", whereas

Safari and Chrome expect a MIME type. Unlike `getData()`, however, Safari and Chrome won't recognize the "text" type. Only Internet Explorer 8 and earlier allow honors calling `setData()`; other browsers simply ignore the call. To even out the differences, you can use the following cross-browser methods:

```
function getClipboardText(event) {
    var clipboardData = (event.clipboardData || window.clipboardData);
    return clipboardData.getData("text");
}

function setClipboardText (event, value){
    if (event.clipboardData){
        return event.clipboardData.setData("text/plain", value);
    } else if (window.clipboardData){
        return window.clipboardData.setData("text", value);
    }
}
```

The `getClipboardText()` function is relatively simple. It needs only to identify the location of the `clipboardData` object and then call `getData()` with a type of "text". Its companion method, `setClipboardText()`, is slightly more involved. Once the `clipboardData` object is located, `setData()` is called with the appropriate type for each implementation ("text/plain" for Firefox, Safari, and Chrome; "text" for Internet Explorer).

Reading text from the clipboard is helpful when you have a text box that expects only certain characters or a certain format of text. For example, if a text box allows only numbers, then pasted values must also be inspected to ensure that the value is valid. In the `paste` event, you can determine if the text on the clipboard is invalid and, if so, cancel the default behavior, as shown in the following example:

```
textbox.addEventListener("paste", (event) => {
    let text = getClipboardText(event);

    if (!/^\d*$/.test(text)){
        event.preventDefault();
    }
});
```

This `onpaste` handler ensures that only numeric values can be pasted into the text box. If the clipboard value doesn't match the pattern, then the paste is canceled. Firefox, Safari, and Chrome allow access to the `getData()` method only in an `onpaste` event handler.

Because not all browsers support clipboard access, it's often easier to block one or more of the clipboard operations. In browsers that support the `copy`, `cut`, and `paste` events (Internet Explorer, Safari, Chrome, and Firefox), it's easy to prevent the event's default behavior. For Opera, you need to block the keystrokes that cause the events and block the context menu from being displayed.

Automatic Tab Forward

JavaScript can be used to increase the usability of form fields in a number of ways. One of the most common is to automatically move the focus to the next field when the current field is complete.

This is frequently done when entering data whose appropriate length is already known, such as for

telephone numbers. In the United States, telephone numbers are typically split into three parts: the area code, the exchange, and then four more digits. It's quite common for web pages to represent this as three text boxes, such as the following:

```
<input type="text" name="tel1" id="txtTel1" maxlength="3">
<input type="text" name="tel2" id="txtTel2" maxlength="3">
<input type="text" name="tel3" id="txtTel3" maxlength="4">
```

To aid in usability and speed up the data-entry process, you can automatically move focus to the next element as soon as the maximum number of characters has been entered. So once the user types three characters in the first text box, the focus moves to the second, and once the user types three characters in the second text box, the focus moves to the third. This "tab forward" behavior can be accomplished using the following code:

```
<script>
  function tabForward(event){
    let target = event.target;

    if (target.value.length == target.maxLength){
      let form = target.form;

      for (let i = 0, len = form.elements.length; i < len; i++) {
        if (form.elements[i] == target) {
          if (form.elements[i+1]) {
            form.elements[i+1].focus();
          }
          return;
        }
      }
    }
  }

  let inputIds = ["txtTel1", "txtTel2", "txtTel3"];

  for (let id of inputIds) {
    let textbox = document.getElementById(id);
    textbox.addEventListener("keyup", tabForward);
  }

  let textbox1 = document.getElementById("txtTel1");
  let textbox2 = document.getElementById("txtTel2");
  let textbox3 = document.getElementById("txtTel3");
</script>
```

The `tabForward()` function is the key to this functionality. It checks to see if the text box's maximum length has been reached by comparing the value to the `maxLength` attribute. If they're equal (because the browser enforces the maximum, there's no way it could be more), then the next form element needs to be found by looping through the elements collection until the text box is found and then setting focus to the element in the next position. This function is then assigned as the `onkeyup` handler for each text box. Since the `keyup` event fires after a new character has been inserted into the text box, this is the ideal time to check the length of the text box contents. When filling out this simple form, the user will never have to press the Tab key to move between fields and submit the form.

Keep in mind that this code is specific to the markup mentioned previously and doesn't take into account possible hidden fields.

HTML5 Constraint Validation API

HTML5 introduces the ability for browsers to validate data in forms before submitting to the server. This capability enables basic validation even when JavaScript is unavailable or fails to load. The browser itself handles performing the validation based on rules in the code and then displays appropriate error messages on its own (without needing additional JavaScript). This functionality works only in browsers that support this part of HTML5, which includes all modern browsers (except for Safari) and IE 10+.

Validation is applied to a form field only under certain conditions. You can use HTML markup to specify constraints on a particular field that will result in the browser automatically performing form validation.

Required Fields

The first condition is when a form field has a `required` attribute, as in this example:

```
<input type="text" name="username" required>
```

Any field marked as `required` must have a value in order for the form to be submitted. This attribute applies to `<input>`, `<textarea>`, and `<select>` fields (Opera through version 11 doesn't support `required` on `<select>`). You can check to see if a form field is required in JavaScript by using the corresponding `required` property on the element:

```
let isUsernameRequired = document.forms[0].elements["username"].required;
```

You can also test to see if the browser supports the `required` attribute using this code snippet:

```
let isRequiredSupported = "required" in document.createElement("input");
```

This code uses simple feature detection to determine if the property `required` exists on a newly created `<input>` element.

Keep in mind that different browsers behave differently when a form field is required. Firefox, Chrome, IE, and Opera prevent the form from submitting and pop up a help box beneath the field, while Safari does nothing and doesn't prevent the form from submitting.

Alternate Input Types

HTML5 specifies several additional values for the `type` attribute on an `<input>` element. These type attributes not only provide additional information about the type of data expected but also provide some default validation. The two new input types that are most widely supported are `"email"` and `"url"`, and each comes with a custom validation that the browser applies. For example:

```
<input type="email" name="email">  
<input type="url" name="homepage">
```

The `"email"` type ensures that the input text matches the pattern for an e-mail address, while the `"url"` type ensures that the input text matches the pattern for a URL. Note that the browsers

As mentioned earlier in this section all have some issues with proper pattern matching. Most notably, the text "-@-" is considered a valid e-mail address. Such issues are still being addressed with browser vendors.

You can detect if a browser supports these new types by creating an element in JavaScript and setting the type property to "email" or "url" and then reading the value back. Older browsers automatically set unknown values back to "text", while supporting browsers echo the correct value back. For example:

```
let input = document.createElement("input");
input.type = "email";
let isEmailSupported = (input.type == "email");
```

Keep in mind that an empty field is also considered valid unless the `required` attribute is applied. Also, specifying a special input type doesn't prevent the user from entering an invalid value; it only applies some default validation.

Numeric Ranges

In addition to "email" and "url", there are several other new input element types defined in HTML5. These are all numeric types that expect some sort of numbers-based input: "number", "range", "datetime", "datetime-local", "date", "month", "week", and "time". These types are not supported across all major browsers and thus should be used carefully. Browser vendors are working toward better cross-compatibility and more logical functionality at this time. Therefore, the information in this section is more forward looking rather than explanatory of existing functionality.

For each of these numeric types, you can specify a `min` attribute (the smallest possible value), a `max` attribute (the largest possible value), and a `step` attribute (the difference between individual steps along the scale from `min` to `max`). For instance, to allow only multiples of 5 between 0 and 100, you could use the following:

```
<input type="number" min="0" max="100" step="5" name="count">
```

Depending on the browser, you may or may not see a spin control (up and down buttons) to automatically increment or decrement the browser.

Each of the attributes have corresponding properties on the element that are accessible (and changeable) using JavaScript. Additionally, there are two methods: `stepUp()` and `stepDown()`. These methods each accept an optional argument: the number to either subtract or add from the current value. (By default, they increment or decrement by one.) The methods have not yet been implemented by browsers but will be usable as in this example:

```
input.stepUp(); // increment by 1
input.stepUp(5); // increment by 5
input.stepDown(); // decrement by 1
input.stepDown(10); // decrement by 10
```

Input Patterns

The `pattern` attribute was introduced for text fields in HTML5. This attribute specifies a regular expression with which the input value must match. For example, to allow only numbers in a text field, the following code applies this constraint:

```
<input type="text" pattern="\d+" name="count">
```

Note that `^` and `$` are assumed at the beginning and end of the pattern, respectively. That means the input must exactly match the pattern from beginning to end.

As with the alternate input types, specifying a `pattern` does not prevent the user from entering invalid text. The pattern is applied to the value, and the browser then knows if the value is valid or not. You can read the pattern by accessing the `pattern` property:

```
let pattern = document.forms[0].elements["count"].pattern;
```

You can also test to see if the browser supports the `pattern` attribute using this code snippet:

```
let isPatternSupported = "pattern" in document.createElement("input");
```

Checking Validity

You can check if any given field on the form is valid by using the `checkValidity()` method. This method is provided on all elements and returns `true` if the field's value is valid or `false` if not. Whether or not a field is valid is based on the conditions previously mentioned in this section, so a required field without a value is considered invalid, and a field whose value does not match the `pattern` attribute is considered invalid. For example:

```
if (document.forms[0].elements[0].checkValidity()) {
  // field is valid, proceed
} else {
  // field is invalid
}
```

To check if the entire form is valid, you can use the `checkValidity()` method on the form itself. This method returns `true` if all form fields are valid and `false` if even one is not:

```
if(document.forms[0].checkValidity()){
  // form is valid, proceed
} else {
  // form field is invalid
}
```

While `checkValidity()` simply tells you if a field is valid or not, the `validity` property indicates exactly why the field is valid or invalid. This object has a series of properties that return a Boolean value:

- `customError`—true if `setCustomValidity()` was set, false if not.
- `patternMismatch`—true if the value doesn't match the specified `pattern` attribute.
- `rangeOverflow`—true if the value is larger than the `max` value.
- `rangeUnderflow`—true if the value is smaller than the `min` value.
- `stepMismatch`—true if the value isn't correct given the `step` attribute in combination with `min` and `max`.
- `tooLong`—true if the value has more characters than allowed by the `maxLength` property. Some browsers, such as Firefox 4, automatically constrain the character count, and so this value may always be false.

- `typeMismatch`—value is not in the required format of either "email" or "url".
- `valid`—true if every other property is false. Same value that is required by `checkValidity()`.
- `valueMissing`—true if the field is marked as required and there is no value.

Therefore, you may wish to check the validity of a form field using `validity` to get more specific information, as in the following code:

```
if (input.validity && !input.validity.valid){
  if (input.validity.valueMissing){
    console.log("Please specify a value.")
  } else if (input.validity.typeMismatch){
    console.log("Please enter an email address.");
  } else {
    console.log("Value is invalid.");
  }
}
```

Disabling Validation

You can instruct a form not to apply any validation to a form by specifying the `novalidate` attribute:

```
<form method="post" action="/signup" novalidate>
  <!-- form elements here -->
</form>
```

This value can also be retrieved or set by using the JavaScript property `noValidate`, which is set to `true` if the attribute is present and `false` if the attribute is omitted:

```
document.forms[0].noValidate = true; //turn off validation
```

If there are multiple submit buttons in a form, you can specify that the form not validate when a particular submit button is used by adding the `formnovalidate` attribute to the button itself:

```
<form method="post" action="/foo">
  <!-- form elements here -->
  <input type="submit" value="Regular Submit">
  <input type="submit" formnovalidate name="btnNoValidate"
    value="Non-validating Submit">
</form>
```

In this example, the first submit button will cause the form to validate as usual while the second disables validation when submitting. You can also set this property using JavaScript:

```
// turn off validation
document.forms[0].elements["btnNoValidate"].formNoValidate = true;
```

SCRIPTING SELECT BOXES

Select boxes are created using the `<select>` and `<option>` elements. To allow for easier interaction with the control, the `HTMLSelectElement` type provides the following properties and methods in addition to those that are available on all form fields:

- `add(newOption, relOption)`—Adds a new `<option>` element to the control before the related option.

- `multiple`—A Boolean value indicating if multiple selections are allowed; equivalent to the HTML `multiple` attribute.
- `options`—An `HTMLCollection` of `<option>` elements in the control.
- `remove(index)`—Removes the option in the given position.
- `selectedIndex`—The zero-based index of the selected option or `-1` if no options are selected. For select boxes that allow multiple selections, this is always the first option in the selection.
- `size`—The number of rows visible in the select box; equivalent to the HTML `size` attribute.

The `type` property for a select box is either `"select-one"` or `"select-multiple"`, depending on the absence or presence of the `multiple` attribute. The option that is currently selected determines a select box's `value` property according to the following rules:

- If there is no option selected, the value of a select box is an empty string.
- If an option is selected and it has a `value` attribute specified, then the select box's value is the `value` attribute of the selected option. This is true even if the `value` attribute is an empty string.
- If an option is selected and it doesn't have a `value` attribute specified, then the select box's value is the text of the option.
- If multiple options are selected, then the select box's value is taken from the first selected option according to the previous two rules.

Consider the following select box:

```
<select name="location" id="selLocation">
  <option value="Sunnyvale, CA">Sunnyvale</option>
  <option value="Los Angeles, CA">Los Angeles</option>
  <option value="Mountain View, CA">Mountain View</option>
  <option value="">China</option>
  <option>Australia</option>
</select>
```

If the first option in this select box is selected, the value of the field is `"Sunnyvale, CA"`. If the option with the text `"China"` is selected, then the field's value is an empty string because the `value` attribute is empty. If the last option is selected, then the value is `"Australia"` because there is no `value` attribute specified on the `<option>`.

Each `<option>` element is represented in the DOM by an `HTMLOptionElement` object. The `HTMLOptionElement` type adds the following properties for easier data access:

- `index`—The option's index inside the `options` collection.
- `label`—The option's label; equivalent to the HTML `label` attribute.
- `selected`—A Boolean value used to indicate if the option is selected. Set this property to `true` to select an option.
- `text`—The option's text.
- `value`—The option's value (equivalent to the HTML `value` attribute).

Most of the `<option>` properties are used for faster access to the option data. Normal DOM functionality can be used to access this information, but it's quite inefficient, as this example shows:

```
let selectbox = document.forms[0].elements["location"];

// not recommended
let text = selectbox.options[0].firstChild.nodeValue; // option text
let value = selectbox.options[0].getAttribute("value"); // option value
```

This code gets the text and value of the first option in the select box using standard DOM techniques. Compare this to using the special option properties:

```
let selectbox = document.forms[0].elements["location"];

// preferred
let text = selectbox.options[0].text; // option text
let value = selectbox.options[0].value; // option value
```

When dealing with options, it's best to use the option-specific properties because they are well supported across all browsers. The exact interactions of form controls may vary from browser to browser when manipulating DOM nodes. It is not recommended to change the text or values of `<option>` elements by using standard DOM techniques.

As a final note, there is a difference in the way the `change` event is used for select boxes. As opposed to other form fields, which fire the `change` event after the value has changed and the field loses focus, the `change` event fires on select boxes as soon as an option is selected.

NOTE *There are differences in what the `value` property returns across browsers. The `value` property is always equal to the `value` attribute in all browsers. When the `value` attribute is not specified, Internet Explorer 8 and earlier versions return an empty string, whereas Internet Explorer 9+, Safari, Firefox, Chrome, and Opera return the same value as `text`.*

Options Selection

For a select box that allows only one option to be selected, the easiest way to access the selected option is by using the select box's `selectedIndex` property to retrieve the option, as shown in the following example:

```
let selectedOption = selectbox.options[selectbox.selectedIndex];
```

This can be used to display all of the information about the selected option, as in this example:

```
let selectedIndex = selectbox.selectedIndex;
let selectedOption = selectbox.options[selectedIndex];
console.log('Selected index: ${selectedIndex}\n' +
  'Selected text: ${selectedOption.text}\n' +
  'Selected value: ${selectedOption.value}');
```

Here, a log message is displayed showing the selected index along with the text and value of the selected option.

When used in a select box that allows multiple selections, the `selectedIndex` property acts as if only one selection was allowed. Setting `selectedIndex` removes all selections and selects just the single option specified, whereas getting `selectedIndex` returns only the index of the first option that was selected.

Options can also be selected by getting a reference to the option and setting its `selected` property to `true`. For example, the following selects the first option in a select box:

```
selectbox.options[0].selected = true;
```

Unlike `selectedIndex`, setting the option's `selected` property does not remove other selections when used in a multiselect select box, allowing you to dynamically select any number of options. If an option's `selected` property is changed in a single-select select box, then all other selections are removed. It's worth noting that setting the `selected` property to `false` has no effect in a single-select select box.

The `selected` property is helpful in determining which options in a select box are selected. To get all of the selected options, you can loop over the options collection and test the `selected` property. Consider this example:

```
function getSelectedOptions(selectbox) {
  let result = new Array();

  for (let option of selectbox.options) {
    if (option.selected) {
      result.push(option);
    }
  }

  return result;
}
```

This function returns an array of options that are selected in a given select box. First an array to contain the results is created. Then a `for` loop iterates over the options, checking each option's `selected` property. If the option is selected, it is added to the `result` array. The last step is to return the array of selected options. The `getSelectedOptions()` function can then be used to get information about the selected options, like this:

```
let selectbox = document.getElementById("selLocation");
let selectedOptions = getSelectedOptions(selectbox);
let message = "";

for (let option of selectedOptions) {
  message += 'Selected index: ${option.index}\n' +
    'Selected text: ${option.text}\n' +
    'Selected value: ${option.value}\n'
}

console.log(message);
```

In this example, the selected options are retrieved from a select box. A `for` loop is used to construct a message containing information about all of the selected options, including each option's index, text, and value. This can be used for select boxes that allow single or multiple selection.

Adding Options

There are several ways to create options dynamically and add them to select boxes using JavaScript. The first way is to use the DOM as follows:

```
let newOption = document.createElement("option");
newOption.appendChild(document.createTextNode("Option text"));
newOption.setAttribute("value", "Option value");

selectbox.appendChild(newOption);
```

This code creates a new `<option>` element, adds some text using a text node, sets its `value` attribute, and then adds it to a select box. The new option shows up immediately after being created.

New options can also be created using the `Option` constructor, which is a holdover from pre-DOM browsers. The `Option` constructor accepts two arguments, the `text` and the `value`, though the second argument is optional. Even though this constructor is used to create an instance of `Object`, DOM-compliant browsers return an `<option>` element. This means you can still use `appendChild()` to add the option to the select box. Consider the following:

```
let newOption = new Option("Option text", "Option value");
selectbox.appendChild(newOption); // problems in IE <= 8
```

This approach works as expected in all browsers except Internet Explorer 8 and earlier. Because of a bug, the browser doesn't correctly set the text of the new option when using this approach.

Another way to add a new option is to use the select box's `add()` method. The DOM specifies that this method accepts two arguments: the new option to add and the option before which the new option should be inserted. To add an option at the end of the list, the second argument should be `null`. The Internet Explorer 8 and earlier implementation of `add()` is slightly different in that the second argument is optional, and it must be the index of the option before which to insert the new option. DOM-compliant browsers require the second argument, so you can't use just one argument for a cross-browser approach (Internet Explorer 9 is DOM-compliant). Instead, passing `undefined` as the second argument ensures that the option is added at the end of the list in all browsers. Here's an example:

```
let newOption = new Option("Option text", "Option value");
selectbox.add(newOption, undefined); // best solution
```

This code works appropriately in all versions of Internet Explorer and DOM-compliant browsers. If you need to insert a new option into a position other than last, you should use the DOM technique and `insertBefore()`.

NOTE *As in HTML, you are not required to assign a value for an option. The `Option` constructor works with just one argument (the option text).*

Removing Options

As with adding options, there are multiple ways to remove options. You can use the DOM `removeChild()` method and pass in the option to remove, as shown here:

```
selectbox.removeChild(selectbox.options[0]); // remove first option
```

The second way is to use the select box's `remove()` method. This method accepts a single argument, the index of the option to remove, as shown here:

```
selectbox.remove(0); // remove first option
```

The last way is to simply set the option equal to `null`. This is also a holdover from pre-DOM browsers. Here's an example:

```
selectbox.options[0] = null; // remove first option
```

To clear a select box of all options, you need to iterate over the options and remove each one, as in this example:

```
function clearSelectbox(selectbox) {
  for (let option of selectbox.options) {
    selectbox.remove(0);
  }
}
```

This function simply removes the first option in a select box repeatedly. Because removing the first option automatically moves all of the options up one spot, this removes all options.

Moving and Reordering Options

Before the DOM, moving options from one select box to another was a rather arduous process that involved removing the option from the first select box, creating a new option with the same name and value, and then adding that new option to the second select box. Using DOM methods, it's possible to literally move an option from the first select box into the second select box by using the `appendChild()` method. If you pass an element that is already in the document into this method, the element is removed from its parent and put into the position specified. For example, the following code moves the first option from one select box into another select box.

```
let selectbox1 = document.getElementById("selLocations1");
let selectbox2 = document.getElementById("selLocations2");

selectbox2.appendChild(selectbox1.options[0]);
```

Moving options is the same as removing them in that the `index` property of each option is reset.

Reordering options is very similar, and DOM methods are the best way to accomplish this. To move an option to a particular location in the select box, the `insertBefore()` method is most appropriate, though the `appendChild()` method can be used to move any option to the last position. To move an option up one spot in the select box, you can use the following code:

```
let optionToMove = selectbox.options[1];
selectbox.insertBefore(optionToMove,
  selectbox.options[optionToMove.index-1]);
```

In this code, an option is selected to move and then inserted before the option that is in the previous index. The second line of code is generic enough to work with any option in the select box except the first. The following similar code can be used to move an option down one spot:

```
let optionToMove = selectbox.options[1];
selectbox.insertBefore(optionToMove,
  selectbox.options[optionToMove.index+2]);
```

This code works for all options in a select box, including the last one.

FORM SERIALIZATION

With the emergence of Ajax (discussed further in Chapter 21), *form serialization* has become a common requirement. A form can be serialized in JavaScript using the `type` property of form fields in conjunction with the `name` and `value` properties. Before writing the code, you need to understand how the browser determines what gets sent to the server during a form submission:

- Field names and values are URL-encoded and delimited using an ampersand.
- Disabled fields aren't sent at all.
- A check box or radio field is sent only if it is checked.
- Buttons of type "reset" or "button" are never sent.
- Multiselect fields have an entry for each value selected.
- When the form is submitted by clicking a submit button, that submit button is sent; otherwise no submit buttons are sent. Any `<input>` elements with a `type` of "image" are treated the same as submit buttons.
- The value of a `<select>` element is the `value` attribute of the selected `<option>` element. If the `<option>` element doesn't have a `value` attribute, then the value is the text of the `<option>` element.

Form serialization typically doesn't include any button fields, because the resulting string will most likely be submitted in another way. All of the other rules should be followed. The code to accomplish form serialization is as follows:

```
function serialize(form) {
  let parts = [];
  let optValue;

  for (let field of form.elements) {
    switch(field.type) {
      case "select-one":
      case "select-multiple":
        if (field.name.length) {
          for (let option of field.options) {
            if (option.selected) {
              if (option.hasAttribute) {
                optValue = (option.hasAttribute("value") ?
                  option.value : option.text);
              } else {
                optValue = (option.attributes["value"].specified ?
                  option.value : option.text);
              }
            }
            parts.push(encodeURIComponent(field.name) + "=" +
              encodeURIComponent(optValue));
          }
        }
    }
  }
}
```

```

        break;
    case undefined:    // fieldset
    case "file":       // file input
    case "submit":     // submit button
    case "reset":      // reset button
    case "button":     // custom button
        break;
    case "radio":      // radio button
    case "checkbox":      // checkbox
        if (!field.checked) {
            break;
        }
    default:
        // don't include form fields without names
        if (field.name.length) {
            parts.push('${encodeURIComponent(field.name)}=' +
                '${encodeURIComponent(field.value)}');
        }
    }
    return parts.join("&");
}

```

The `serialize()` function begins by defining an array called `parts` to hold the parts of the string that will be created. Next, a `for` loop iterates over each form field, storing it in the `field` variable. Once a field reference is obtained, its `type` is checked using a `switch` statement. The most involved field to serialize is the `<select>` element, in either single-select or multiselect mode. Serialization is done by looping over all of the options in the control and adding a value if the option is selected. For single-select controls, there will be only one option selected, whereas multiselect controls may have zero or more options selected. The same code can be used for both select types, because the restriction on the number of selections is enforced by the browser. When an option is selected, you need to determine which value to use. If the `value` attribute is not present, the `text` should be used instead, although a `value` attribute with an empty string is completely valid. To check this, you'll need to use `hasAttribute()` in DOM-compliant browsers and the attribute's `specified` property in Internet Explorer 8 and earlier.

If a `<fieldset>` element is in the form, it appears in the `elements` collection but has no `type` property. So if `type` is `undefined`, no serialization is necessary. The same is true for all types of buttons and file input fields. (File input fields contain the content of the file in form submissions; however, these fields can't be mimicked, so they are typically omitted in serialization.) For radio and check box controls, the `checked` property is inspected and if it is set to `false`, the `switch` statement is exited. If `checked` is `true`, then the code continues executing in the default statement, which encodes the name and value of the field and adds it to the `parts` array. Note that in all cases form fields without names are not included as part of the serialization to mimic browser form submission behavior. The last part of the function uses `join()` to format the string correctly with ampersands between fields.

The `serialize()` function outputs the string in query string format, though it can easily be adapted to serialize the form into another format.

RICH TEXT EDITING

One of the most requested features for web applications was the ability to edit rich text on a web page (also called *what you see is what you get*, or WYSIWYG, editing). Though no specification covers this, a de facto standard has emerged from functionality originally introduced by Internet Explorer and now supported by Opera, Safari, Chrome, and Firefox. The basic technique is to embed an `iframe` containing a blank HTML file in the page. Through the `designMode` property, this blank document can be made editable, at which point you're editing the HTML of the page's `<body>` element. The `designMode` property has two possible values: `"off"` (the default) and `"on"`. When set to `"on"`, an entire document becomes editable (showing a caret), allowing you to edit text as if you were using a word processor complete with keystrokes for making text bold, italic, and so forth.

A very simple, blank HTML page is used as the source of the `iframe`. Here's an example:

```
<!DOCTYPE html>
<html>
  <head>
    <title>Blank Page for Rich Text Editing</title>
  </head>
  <body>
  </body>
</html>
```

This page is loaded inside an `iframe` as any other page would be. To allow it to be edited, you must set `designMode` to `"on"`, but this can happen only after the document is fully loaded. In the containing page, you'll need to use the `onload` event handler to indicate the appropriate time to set `designMode`, as shown in the following example:

```
<iframe name="richedit" style="height: 100px; width: 100px"></iframe>

<script>
  window.addEventListener("load", () => {
    frames["richedit"].document.designMode = "on";
  });
</script>
```

Once this code is loaded, you'll see what looks like a text box on the page. The box has the same default styling as any web page, though this can be adjusted by applying CSS to the blank page.

Using contenteditable

Another way to interact with rich text, also first implemented by Internet Explorer, is through the use of a special attribute called `contenteditable`. The `contenteditable` attribute can be applied to any element on a page and instantly makes that element editable by the user. This approach has gained favor because it doesn't require the overhead of an `iframe`, blank page, and JavaScript. Instead, you can just add the attribute to an element:

```
<div class="editable" id="richedit" contenteditable></div>
```

Any text already contained within the element is automatically made editable by the user, making it behave similarly to the `<textarea>` element. You can also toggle the editing mode on or off by setting the `contentEditable` property on an element:

```
let div = document.getElementById("richedit");
richedit.contentEditable = "true";
```

There are three possible values for `contentEditable`: `"true"` to turn on, `"false"` to turn off, or `"inherit"` to inherit the setting from a parent (required because elements can be created/destroyed inside of a `contentEditable` element). The `contentEditable` attribute is supported in Internet Explorer, Firefox, Chrome, Safari, and Opera, and on all major mobile browsers.

NOTE `contentEditable` is an extremely versatile attribute. For example, you're able to convert your browser window into a notepad by visiting the pseudo-URL `data:text/html, <html contentEditable>`. This creates an ad-hoc DOM with the entire document set to editable.

Interacting with Rich Text

The primary method of interacting with a rich text editor is through the use of `document.execCommand()`. This method executes named commands on the document and can be used to apply most formatting changes. There are three possible arguments for `document.execCommand()`: the name of the command to execute, a Boolean value indicating if the browser should provide a user interface for the command, and a value necessary for the command to work (or `null` if none is necessary). The second argument should always be `false` for cross-browser compatibility, because Firefox throws an error when `true` is passed in.

Each browser supports a different set of commands. The most commonly supported commands are listed in the following table.

COMMAND	VALUE (THIRD ARGUMENT)	DESCRIPTION
<code>backcolor</code>	A color string	Sets the background color of the document.
<code>bold</code>	<code>null</code>	Toggles bold text for the text selection.
<code>copy</code>	<code>null</code>	Executes a clipboard copy on the text selection.
<code>createlink</code>	A URL string	Turns the current text selection into a link that goes to the given URL.
<code>cut</code>	<code>null</code>	Executes a clipboard cut on the text selection.

continues

(continued)

COMMAND	VALUE (THIRD ARGUMENT)	DESCRIPTION
delete	null	Deletes the currently selected text.
fontname	The font name	Changes the text selection to use the given font name.
fontsize	1 through 7	Changes the font size for the text selection.
forecolor	A color string	Changes the text color for the text selection.
formatblock	The HTML tag to surround the block with; for example, <h1>	Formats the entire text box around the selection with a particular HTML tag.
indent	null	Indents the text.
inserthorizontalrule	null	Inserts an <hr> element at the caret location.
insertimage	The image URL	Inserts an image at the caret location.
insertorderedlist	null	Inserts an element at the caret location.
insertparagraph	null	Inserts a <p> element at the caret location.
insertunorderedlist	null	Inserts a element at the caret location.
italic	null	Toggles italic text for the text selection.
justifycenter	null	Centers the block of text in which the caret is positioned.
justifyleft	null	Left-aligns the block of text in which the caret is positioned.
outdent	null	Outdents the text.
paste	null	Executes a clipboard paste on the text selection.
removeformat	null	Removes block formatting from the block in which the caret is positioned. This is the opposite of formatblock.

COMMAND	VALUE (THIRD ARGUMENT)	DESCRIPTION
selectall	null	Selects all of the text in the document.
underline	null	Toggles underlined text for the text selection.
unlink	null	Removes a text link. This is the opposite of createlink.

The clipboard commands are very browser-dependent. Note that even though these commands aren't all available via `document.execCommand()`, they still work with the appropriate keyboard shortcuts.

These commands can be used at any time to modify the appearance of the iframe rich text area, as in this example:

```
// toggle bold text in an iframe
frames["richedit"].document.execCommand("bold", false, null);

// toggle italic text in an iframe
frames["richedit"].document.execCommand("italic", false, null);

// create link to www.wrox.com in an iframe
frames["richedit"].document.execCommand("createlink", false,
    "http://www.wrox.com");

// format as first-level heading in an iframe
frames["richedit"].document.execCommand("formatblock", false, "<h1>");
```

You can use the same methods to act on a `contenteditable` section of the page; just use the `document` object of the current window instead of referencing the iframe:

```
// toggle bold text
document.execCommand("bold", false, null);

// toggle italic text
document.execCommand("italic", false, null);

// create link to www.wrox.com
document.execCommand("createlink", false, "http://www.wrox.com");

// format as first-level heading
document.execCommand("formatblock", false, "<h1>");
```

Note that even when commands are supported across all browsers, the HTML that the commands produce is often very different. For instance, applying the `bold` command surrounds text with `` in Internet Explorer and Opera, with `` in Safari and Chrome, and with a `` in Firefox. You cannot rely on consistency in the HTML produced from a rich text editor, because of both command implementation and the transformations done by `innerHTML`.

There are some other methods related to commands. The first is `queryCommandEnabled()`, which determines if a command can be executed given the current text selection or caret position. This method accepts a single argument, the command name to check, and returns `true` if the command is allowed given the state of the editable area or `false` if not. Consider this example:

```
let result = frames["richedit"].document.queryCommandEnabled("bold");
```

This code returns `true` if the "bold" command can be executed on the current selection. It's worth noting that `queryCommandEnabled()` indicates not if you are allowed to execute the command but only if the current selection is appropriate for use with the command. In Firefox, `queryCommandEnabled("cut")` returns `true` even though it isn't allowed by default.

The `queryCommandState()` method lets you determine if a given command has been applied to the current text selection. For example, to determine if the text in the current selection is bold, you can use the following:

```
let isBold = frames["richedit"].document.queryCommandState("bold");
```

If the "bold" command was previously applied to the text selection, then this code returns `true`. This is the method by which full-featured rich text editors are able to update buttons for bold, italic, and so on.

The last method is `queryCommandValue()`, which is intended to return the value with which a command was executed. (The third argument in `execCommand` is in the earlier example.) For instance, a range of text that has the "fontSize" command applied with a value of 7 returns "7" from the following:

```
let fontSize = frames["richedit"].document.queryCommandValue("fontSize");
```

This method can be used to determine how a command was applied to the text selection, allowing you to determine whether the next command is appropriate to be executed.

Rich Text Selections

You can determine the exact selection in a rich text editor by using the `getSelection()` method of the `iframe`. This method is available on both the `document` object and the `window` object and returns a `Selection` object representing the currently selected text. Each `Selection` object has the following properties:

- `anchorNode`—The node in which the selection begins.
- `anchorOffset`—The number of characters within the `anchorNode` that are skipped before the selection begins.
- `focusNode`—The node in which the selection ends.
- `focusOffset`—The number of characters within the `focusNode` that are included in the selection.
- `isCollapsed`—Boolean value indicating if the start and end of the selection are the same.
- `rangeCount`—The number of DOM ranges in the selection.

The properties for a `Selection` don't contain a lot of useful information. Fortunately, the following methods provide more information and allow manipulation of the selection:

- `addRange(range)`—Adds the given DOM range to the selection.
- `collapse(node, offset)`—Collapses the selection to the given text offset within the given node.
- `collapseToEnd()`—Collapses the selection to its end.
- `collapseToStart()`—Collapses the selection to its start.
- `containsNode(node)`—Determines if the given node is contained in the selection.
- `deleteFromDocument()`—Deletes the selection text from the document. This is the same as `execCommand("delete", false, null)`.
- `extend(node, offset)`—Extends the selection by moving the `focusNode` and `focusOffset` to the values specified.
- `getRangeAt(index)`—Returns the DOM range at the given index in the selection.
- `removeAllRanges()`—Removes all DOM ranges from the selection. This effectively removes the selection, because there must be at least one range in a selection.
- `removeRange(range)`—Removes the specified DOM range from the selection.
- `selectAllChildren(node)`—Clears the selection and then selects all child nodes of the given node.
- `toString()`—Returns the text content of the selection.

The methods of a `Selection` object are extremely powerful and make extensive use of DOM ranges to manage the selection. Access to DOM ranges allows you to modify the contents of the rich text editor in even finer-grain detail than is available using `execCommand()` because you can directly manipulate the DOM of the selected text. Consider the following example:

```
let selection = frames["richedit"].getSelection();

// get selected text
let selectedText = selection.toString();

// get the range representing the selection
let range = selection.getRangeAt(0);

// highlight the selected text
let span = frames["richedit"].document.createElement("span");
span.style.backgroundColor = "yellow";
range.surroundContents(span);
```

This code places a yellow highlight around the selected text in a rich text editor. Using the DOM range in the default selection, the `surroundContents()` method surrounds the selection with a `` element whose background color is yellow.

The `getSelection()` method was standardized in HTML5 and is implemented in Internet Explorer 9 and all modern versions of Firefox, Safari, Chrome, and Opera.

Internet Explorer 8 and earlier versions don't support DOM ranges, but they do allow interaction with the selected text via the proprietary `selection` object. The `selection` object is a property of `document`, as discussed earlier in this chapter. To get the selected text in a rich text editor, you must first create a text range and then use the `text` property as follows:

```
let range = frames["richedit"].document.selection.createRange();
let selectedText = range.text;
```

Performing HTML manipulations using Internet Explorer text ranges is not as safe as using DOM ranges, but it is possible. To achieve the same highlighting effect as described using DOM ranges, you can use a combination of the `htmlText` property and the `pasteHTML()` method:

```
let range = frames["richedit"].document.selection.createRange();
range.pasteHTML(
  '<span style="background-color:yellow">${range.htmlText}</span>');
```

This code retrieves the HTML of the current selection using `htmlText` and then surrounds it with a `` and inserts it back into the selection using `pasteHTML()`.

Rich Text in Forms

Because rich text editing is implemented using an `iframe` or a `contenteditable` element instead of a form control, a rich text editor is technically not part of a form. That means the HTML will not be submitted to the server unless you extract the HTML manually and submit it yourself. This is typically done by having a hidden form field that is updated with the HTML from the `iframe` or the `contenteditable` element. Just before the form is submitted, the HTML is extracted from the `iframe` or element and inserted into the hidden field. For example, the following may be done in the form's `onsubmit` event handler when using an `iframe`:

```
form.addEventListener("submit", (event) => {
  let target = event.target;

  target.elements["comments"].value =
    frames["richedit"].document.body.innerHTML;
});
```

Here, the HTML is retrieved from the `iframe` using the `innerHTML` property of the document's `body` and inserted into a form field named `"comments"`. Doing so ensures that the `"comments"` field is filled in just before the form is submitted. If you are submitting the form manually using the `submit()` method, take care to perform this operation beforehand. You can perform a similar operation with a `contenteditable` element:

```
form.addEventListener("submit", (event) => {
  let target = event.target;

  target.elements["comments"].value =
    document.getElementById("richedit").innerHTML;
});
```

SUMMARY

Even though HTML and web applications have changed dramatically since their inception, web forms have remained mostly unchanged. JavaScript can be used to augment existing form fields to provide new functionality and usability enhancements. To aid in this, forms and form fields have properties, methods, and events for JavaScript usage. Here are some of the concepts introduced in this chapter:

- It's possible to select all of the text in a text box or just part of the text using a variety of standard and nonstandard methods.
- All browsers have adopted Firefox's way of interacting with text selection, making it a true standard.
- Text boxes can be changed to allow or disallow certain characters by listening for keyboard events and inspecting the characters being inserted.

All browsers support events for the clipboard, including `copy`, `cut`, and `paste`. Clipboard event implementations across the other browsers vary widely between browser vendors.

Hooking into clipboard events is useful for blocking paste events when the contents of a text box must be limited to certain characters.

Select boxes are also frequently controlled using JavaScript. Thanks to the DOM, manipulating select boxes is much easier than it was previously. Options can be added, removed, moved from one select box to another, or reordered using standard DOM techniques.

Rich text editing is handled by using an `iframe` containing a blank HTML document. By setting the document's `designMode` property to "on", you make the page editable and it acts like a word processor. You can also use an element set as `contentEditable`. By default, you can toggle font styles such as bold and italic and use clipboard actions. JavaScript can access some of this functionality by using the `execCommand()` method and can get information about the text selection by using the `queryCommandEnabled()`, `queryCommandState()`, and `queryCommandValue()` methods. Because building a rich text editor in this manner does not create a form field, it's necessary to copy the HTML from the `iframe` or `contentEditable` element into a form field if it is to be submitted to the server.

20

JavaScript APIs

WHAT'S IN THIS CHAPTER?

- Atomics and SharedArrayBuffer
- Cross-context messaging
- Encoding API
- File and Blob API
- Drag and drop
- Notifications API
- Page Visibility API
- Streams API
- Timing APIs
- Web components
- Web Cryptography API

The increasing versatility of web browsers is accompanied by a dizzying increase in complexity. In many ways, the modern web browser has become a Swiss army knife of different APIs detailed in a broad collection of specifications. This browser specification ecosystem is messy and volatile. Some specifications like HTML5 are a bundle of APIs and browser features that enhance an existing standard. Other specifications define an API for a single feature, such as the Web Cryptography API or the Notifications API. Depending on the browser, adoption of these newer APIs can sometimes be partial or nonexistent.

Ultimately, the decision to use newer APIs involves a tradeoff between supporting more browsers and enabling more modern features. Some APIs can be emulated using a polyfill, but polyfills can often incur a performance hit or bloat your site's JS payloads.

NOTE *The number of web APIs is mind-bogglingly huge (<https://developer.mozilla.org/en-US/docs/Web/API>). This chapter's API coverage is limited to APIs that are relevant to most developers, supported by multiple browser vendors, and not covered elsewhere in this book.*

ATOMICS AND SharedArrayBuffer

When a `SharedArrayBuffer` is accessed by multiple contexts, race conditions can occur when operations on the buffer are performed simultaneously. The `Atomics` API allows multiple contexts to safely read and write to a single `SharedArrayBuffer` by forcing buffer operations to occur only one at a time. The `Atomics` API was defined in the ES2017 specification.

You will notice that the `Atomics` API in many ways resembles a stripped-down instruction set architecture (ISA)—this is no accident. The nature of atomic operations precludes some optimizations that the operating system or computer hardware would normally perform automatically (such as instruction reordering). Atomic operations also make concurrent memory access impossible, which obviously can slow program execution when improperly applied. Therefore, the `Atomics` API was designed to enable sophisticated multithreaded JavaScript programs to be architected out of a minimal yet robust collection of atomic behaviors.

SharedArrayBuffer

A `SharedArrayBuffer` features an identical API to an `ArrayBuffer`. The primary difference is that, whereas a reference to an `ArrayBuffer` must be handed off between execution contexts, a reference to a `SharedArrayBuffer` can be used simultaneously by any number of execution contexts.

Sharing memory between multiple execution contexts means that concurrent thread operations become a possibility. Traditional JavaScript operations offer no protection from race conditions resulting from concurrent memory access. The following example demonstrates a race condition between four dedicated workers accessing the same `SharedArrayBuffer`:

```
const workerScript = `
self.onmessage = ({data}) => {
  const view = new Uint32Array(data);

  // Perform 1000000 add operations
  for (let i = 0; i < 1E6; ++i) {
    // Thread-unsafe add operation introduces race condition
    view[0] += 1;
  }

  self.postMessage(null);
};
`;

const workerScriptBlobUrl = URL.createObjectURL(new Blob([workerScript]));
```

```

// Create worker pool of size 4
const workers = [];
for (let i = 0; i < 4; ++i) {
    workers.push(new Worker(workerScriptBlobUrl));
}

// Log the final value after the last worker completes
let responseCount = 0;
for (const worker of workers) {
    worker.onmessage = () => {
        if (++responseCount == workers.length) {
            console.log(`Final buffer value: ${view[0]}`);
        }
    };
}

// Initialize the SharedArrayBuffer
const sharedArrayBuffer = new SharedArrayBuffer(4);
const view = new Uint32Array(sharedArrayBuffer);
view[0] = 1;

// Send the SharedArrayBuffer to each worker
for (const worker of workers) {
    worker.postMessage(sharedArrayBuffer);
}

// (Expected result is 4000001. Actual output will be something like:)
// Final buffer value: 2145106
    
```

To address this problem, the Atomics API was introduced to allow for thread-safe JavaScript operations on a SharedArrayBuffer.

NOTE *The SharedArrayBuffer API is identical to the ArrayBuffer API, which is covered in the “Collection Reference Types” chapter. For details on how to use a SharedArrayBuffer across multiple contexts, refer to the “Workers” chapter.*

Atomics Basics

The Atomics object exists on all global contexts, and it exposes a suite of static methods for performing thread-safe operations. Most of these methods take a TypedArray instance (referencing a SharedArrayBuffer) as the first argument and the relevant operands as subsequent arguments.

Atomic Arithmetic and Bitwise Methods

The Atomics API offers a simple suite of methods for performing an in-place modification. In the ECMA specification, these methods are defined as AtomicReadModifyWrite operations. Under the hood, each of these methods is performing a read from a location in the SharedArrayBuffer, an arithmetic or bitwise operation, and a write to the same location. The atomic nature of these operators means that these three operations will be performed in sequence and without interruption by another thread.

All the arithmetic methods are demonstrated here:

```
// Create buffer of size 1
let sharedArrayBuffer = new SharedArrayBuffer(1);

// Create Uint8Array from buffer
let typedArray = new Uint8Array(sharedArrayBuffer);

// All ArrayBuffers are initialized to 0
console.log(typedArray); // Uint8Array[0]

const index = 0;
const increment = 5;

// Atomic add 5 to value at index 0
Atoms.add(typedArray, index, increment);

console.log(typedArray); // Uint8Array[5]

// Atomic subtract 5 to value at index 0
Atoms.sub(typedArray, index, increment);

console.log(typedArray); // Uint8Array[0]
```

All the bitwise methods are demonstrated here:

```
// Create buffer of size 1
let sharedArrayBuffer = new SharedArrayBuffer(1);

// Create Uint8Array from buffer
let typedArray = new Uint8Array(sharedArrayBuffer);

// All ArrayBuffers are initialized to 0
console.log(typedArray); // Uint8Array[0]

const index = 0;

// Atomic or 0b1111 to value at index 0
Atoms.or(typedArray, index, 0b1111);

console.log(typedArray); // Uint8Array[15]

// Atomic and 0b1100 to value at index 0
Atoms.and(typedArray, index, 0b1100);

console.log(typedArray); // Uint8Array[12]

// Atomic xor 0b1111 to value at index 0
Atoms.xor(typedArray, index, 0b1111);

console.log(typedArray); // Uint8Array[3]
```

The thread-unsafe example from earlier can be corrected as follows:

```
const workerScript = `
self.onmessage = ({data}) => {
```

```

const view = new Uint32Array(data);

// Perform 1000000 add operations
for (let i = 0; i < 1E6; ++i) {
    // Thread-safe add operation
    Atomics.add(view, 0, 1);
}

self.postMessage(null);
};
`;

const workerScriptBlobUrl = URL.createObjectURL(new Blob([workerScript]));

// Create worker pool of size 4
const workers = [];
for (let i = 0; i < 4; ++i) {
    workers.push(new Worker(workerScriptBlobUrl));
}

// Log the final value after the last worker completes
let responseCount = 0;
for (const worker of workers) {
    worker.onmessage = () => {
        if (++responseCount == workers.length) {
            console.log(`Final buffer value: ${view[0]}`);
        }
    };
}

// Initialize the SharedArrayBuffer
const sharedArrayBuffer = new SharedArrayBuffer(4);
const view = new Uint32Array(sharedArrayBuffer);
view[0] = 1;

// Send the SharedArrayBuffer to each worker
for (const worker of workers) {
    worker.postMessage(sharedArrayBuffer);
}

// (Expected result is 4000001)
// Final buffer value: 4000001

```

Atomic Reads and Writes

Both the browser's JavaScript compiler and the CPU architecture itself are given license to reorder instructions if they detect it will increase the overall throughput of program execution. Normally, the single-threaded nature of JavaScript means this optimization should be welcomed with open arms. However, instruction reordering across multiple threads can yield race conditions that are extremely difficult to debug.

The Atomics API addresses this problem in two primary ways:

- All Atomics instructions are never reordered with respect to one another.
- Using an Atomic read or Atomic write guarantees that all instructions (both Atomic and non-Atomic) will never be reordered with respect to that Atomic read/write. This means that all instructions before an Atomic read/write will finish before the Atomic read/write occurs, and all instructions after the Atomic read/write will not begin until the Atomic read/write completes.

In addition to reading and writing values to a buffer, `Atomsics.load()` and `Atomsics.store()` behave as “code fences.” The JavaScript engine guarantees that, although non-Atomic instructions may be *locally* reordered relative to a `load()` or `store()`, the reordering will never violate the Atomic read/write boundary. The following code annotates this behavior:

```
const sharedArrayBuffer = new SharedArrayBuffer(4);
const view = new Uint32Array(sharedArrayBuffer);

// Perform non-Atomic write
view[0] = 1;

// Non-Atomic write is guaranteed to occur before this read,
// so this is guaranteed to read 1
console.log(Atomsics.load(view, 0)); // 1

// Perform Atomic write
Atomsics.store(view, 0, 2);

// Non-Atomic read is guaranteed to occur after Atomic write,
// so this is guaranteed to read 2
console.log(view[0]); // 2
```

Atomic Exchanges

The Atomics API offers two types of methods that guarantee a sequential and uninterrupted read-then-write: `exchange()` and `compareExchange()`. `Atomsics.exchange()` performs a simple swap, guaranteeing that no other threads will interrupt the value swap:

```
const sharedArrayBuffer = new SharedArrayBuffer(4);
const view = new Uint32Array(sharedArrayBuffer);

// Write 3 to 0-index
Atomsics.store(view, 0, 3);

// Read value out of 0-index and then write 4 to 0-index
console.log(Atomsics.exchange(view, 0, 4)); // 3

// Read value at 0-index
console.log(Atomsics.load(view, 0)); // 4
```

One thread in a multithreaded program might want to perform a write to a shared buffer *only* if another thread has not modified a specific value since it was last read. If the value has not changed,

it can safely write the update value. If the value *has* changed, performing a write would trample the value calculated by another thread. For this task, the Atomics API features the `compareExchange()` method. This method only performs a write if the value at the intended index matches an expected value. Consider the following example:

```
const sharedArrayBuffer = new SharedArrayBuffer(4);
const view = new Uint32Array(sharedArrayBuffer);

// Write 5 to 0-index
Atomsic.store(view, 0, 5);
// Read the value out of the buffer
let initial = Atomics.load(view, 0);

// Perform a non-atomic operation on that value
let result = initial ** 2;

// Write that value back into the buffer only if the buffer has not changed
Atomsic.compareExchange(view, 0, initial, result);

// Check that the write succeeded
console.log(Atomsic.load(view, 0)); // 25
```

If the value does not match, the `compareExchange()` call will simply behave as a passthrough:

```
const sharedArrayBuffer = new SharedArrayBuffer(4);
const view = new Uint32Array(sharedArrayBuffer);

// Write 5 to 0-index
Atomsic.store(view, 0, 5);
// Read the value out of the buffer
let initial = Atomics.load(view, 0);

// Perform a non-atomic operation on that value
let result = initial ** 2;

// Write that value back into the buffer only if the buffer has not changed
Atomsic.compareExchange(view, 0, -1, result);

// Check that the write failed
console.log(Atomsic.load(view, 0)); // 5
```

Atomsic Futex Operations and Locks

Multithreaded programs wouldn't amount to much without some sort of locking construct. To address this need, the Atomics API offers several methods modeled on the Linux futex (a portmanteau of *fast user-space mutex*). The methods are fairly rudimentary, but they are intended to be used as a fundamental building block for more elaborate locking constructs.

NOTE All *Atomsic futex* operations only work with an `Int32Array` view. Furthermore, they can only be used inside workers.

`Atomics.wait()` and `Atomics.notify()` are best understood by example. The following rudimentary example spawns four workers to operate on an `Int32Array` of length 1. The spawned workers will take turns obtaining the lock and performing their add operation:

```
const workerScript = `
self.onmessage = ({data}) => {
  const view = new Int32Array(data);

  console.log('Waiting to obtain lock');

  // Halt when encountering the initial value, timeout at 10000ms
  Atomics.wait(view, 0, 0, 1E5);

  console.log('Obtained lock');

  // Add 1 to data index
  Atomics.add(view, 0, 1);

  console.log('Releasing lock');

  // Allow exactly one worker to continue execution
  Atomics.notify(view, 0, 1);

  self.postMessage(null);
};
`;

const workerScriptBlobUrl = URL.createObjectURL(new Blob([workerScript]));

const workers = [];
for (let i = 0; i < 4; ++i) {
  workers.push(new Worker(workerScriptBlobUrl));
}

// Log the final value after the last worker completes
let responseCount = 0;
for (const worker of workers) {
  worker.onmessage = () => {
    if (++responseCount == workers.length) {
      console.log(`Final buffer value: ${view[0]}`);
    }
  };
}

// Initialize the SharedArrayBuffer
const sharedArrayBuffer = new SharedArrayBuffer(8);
const view = new Int32Array(sharedArrayBuffer);

// Send the SharedArrayBuffer to each worker
for (const worker of workers) {
  worker.postMessage(sharedArrayBuffer);
}
```

```

// Release first lock in 1000ms
setTimeout(() => Atomics.notify(view, 0, 1), 1000);

// Waiting to obtain lock
// Waiting to obtain lock
// Waiting to obtain lock
// Waiting to obtain lock
// Obtained lock
// Releasing lock
// Obtained lock
// Releasing lock
// Obtained lock
// Releasing lock
// Obtained lock
// Releasing lock
// Final buffer value: 4

```

Because the `SharedArrayBuffer` is initialized with 0s, each worker will arrive at the `Atomics.wait()` and halt execution. In the halted state, the thread of execution exists inside a *wait queue*, remaining paused until the specified timeout elapses or until `Atomics.notify()` is invoked for that index. After 1000 milliseconds, the top-level execution context will call `Atomics.notify()` to release exactly one of the waiting threads. This thread will finish execution and call `Atomics.notify()` once again, releasing yet another thread. This continues until all the threads have completed execution and transmitted their final `postMessage()`.

The `Atomics` API also features the `Atomics.isLockFree()` method. It is almost certain that you will never need to use this method, as it is designed for high-performance algorithms to decide whether or not obtaining a lock is necessary. The specification offers this description:

Atomics.isLockFree() is an optimization primitive. The intuition is that if the atomic step of an atomic primitive (compareExchange, load, store, add, sub, and, or, xor, or exchange) on a datum of size n bytes will be performed without the calling agent acquiring a lock outside the n bytes comprising the datum, then `Atomics.isLockFree(n)` will return true. High-performance algorithms will use `Atomics.isLockFree` to determine whether to use locks or atomic operations in critical sections. If an atomic primitive is not lock-free then it is often more efficient for an algorithm to provide its own locking.

Atomics.isLockFree(4) always returns true as that can be supported on all known relevant hardware. Being able to assume this will generally simplify programs.

CROSS-CONTEXT MESSAGING

Cross-document messaging, sometimes abbreviated as XDM, is the capability to pass information between different execution contexts, such as web workers or pages from different origins. For example, a page on `www.wrox.com` wants to communicate with a page from `p2p.wrox.com` that is

contained in an `iframe`. Prior to XDM, achieving this communication in a secure manner took a lot of work. XDM formalizes this functionality in a way that is both secure and easy to use.

NOTE *Cross-context messaging is used for communication between windows and communication with workers. This section focuses on using `postMessage()` to communicate with other windows. For coverage on worker messaging, `MessageChannel`, and `BroadcastChannel`, refer to the “Workers” chapter.*

At the heart of XDM is the `postMessage()` method. This method name is used in many parts of HTML5 in addition to XDM and is always used for the same purpose: to pass data into another location.

The `postMessage()` method accepts three arguments: a message, a string indicating the intended recipient origin, and an optional array of transferable objects (only relevant to web workers). The second argument is very important for security reasons and restricts where the browser will deliver the message. Consider this example:

```
let iframeWindow = document.getElementById("myframe").contentWindow;
iframeWindow.postMessage("A secret", "http://www.wrox.com");
```

The last line attempts to send a message into the `iframe` and specifies that the origin must be `"http://www.wrox.com"`. If the origin matches, then the message will be delivered into the `iframe`; otherwise, `postMessage()` silently does nothing. This restriction protects your information should the location of the window change without your knowledge. It is possible to allow posting to any origin by passing in `"*"` as the second argument to `postMessage()`, but this is not recommended.

A `message` event is fired on `window` when an XDM message is received. This message is fired asynchronously so there may be a delay between the time at which the message was sent and the time at which the `message` event is fired in the receiving window. The `event` object that is passed to an `onmessage` event handler has three important pieces of information:

- `data`—The string data that was passed as the first argument to `postMessage()`.
- `origin`—The origin of the document that sent the message, for example, `"http://www.wrox.com"`.
- `source`—A proxy for the window object of the document that sent the message. This proxy object is used primarily to execute the `postMessage()` method on the window that sent the last message. If the sending window has the same origin, this may be the actual window object.

It's very important when receiving a message to verify the origin of the sending window. Just as specifying the second argument to `postMessage()` ensures that data doesn't get passed unintentionally to an unknown page, checking the origin during `onmessage` ensures that the data being passed is coming from the right place. The basic pattern is as follows:

```
window.addEventListener("message", (event) => {
  // ensure the sender is expected
  if (event.origin == "http://www.wrox.com") {
```

```
// do something with the data
processMessage(event.data);
// optional: send a message back to the original window
event.source.postMessage("Received!", "http://p2p.wrox.com");
}
});
```

Keep in mind that `event.source` is a proxy for a window in most cases, not the actual window object, so you can't access all of the window information. It's best to just use `postMessage()`, which is always present and always callable.

There are a few quirks with XDM. First, the first argument of `postMessage()` was initially implemented as always being a string. The definition of that first argument changed to allow any structured data to be passed in; however, not all browsers have implemented this change. For this reason, it's best to always pass a string using `postMessage()`. If you need to pass structured data, then the best approach is to call `JSON.stringify()` on the data, passing the string to `postMessage()`, and then call `JSON.parse()` in the `onmessage` event handler.

XDM is extremely useful when trying to sandbox content using an `iframe` to a different domain. This approach is frequently used in mashups and social networking applications. The containing page is able to keep itself secure against malicious content by only communicating into an embedded `iframe` via XDM. XDM can also be used with pages from the same domain.

ENCODING API

The Encoding API allows for converting between strings and typed arrays. The specification introduces four global classes for performing these conversions: `TextEncoder`, `TextEncoderStream`, `TextDecoder`, and `TextDecoderStream`.

NOTE *Support for stream encoding/decoding is much narrower than bulk encoding/decoding.*

Encoding Text

The Encoding API affords two ways of converting a string into its typed array binary equivalent: a *bulk* encoding, and a *stream* encoding. When going from string to typed array, the encoder will always use UTF-8.

Bulk Encoding

The *bulk* designation means that the JavaScript engine will synchronously encode the entire string. For very long strings, this can be a costly operation. Bulk encoding is accomplished using an instance of a `TextEncoder`:

```
const textEncoder = new TextEncoder();
```

This instance exposes an `encode()` method, which accepts a string and returns each character's UTF-8 encoding inside a freshly created `Uint8Array`:

```
const textEncoder = new TextEncoder();
const decodedText = 'foo';
const encodedText = textEncoder.encode(decodedText);

// f encoded in utf-8 is 0x66 (102 in decimal)
// o encoded in utf-8 is 0x6F (111 in decimal)
console.log(encodedText); // Uint8Array(3) [102, 111, 111]
```

The encoder is equipped to handle characters, which will take up multiple indices in the eventual array, such as emojis:

```
const textEncoder = new TextEncoder();
const decodedText = '🤔';
const encodedText = textEncoder.encode(decodedText);

// 🤔 encoded in UTF-8 is 0xF0 0x9F 0x98 0x8A (240, 159, 152, 138 in decimal)
console.log(encodedText); // Uint8Array(4) [240, 159, 152, 138]
```

The instance also exposes an `encodeInto()` method, which accepts a string *and* the destination `Uint8Array`. This method returns a dictionary containing `read` and `written` properties, indicating how many characters were successfully read from the source string and written to the destination array, respectively. If the typed array has insufficient space, the encoding will terminate early and the dictionary will indicate that result:

```
const textEncoder = new TextEncoder();
const fooArr = new Uint8Array(3);
const barArr = new Uint8Array(2);
const fooResult = textEncoder.encodeInto('foo', fooArr);
const barResult = textEncoder.encodeInto('bar', barArr);

console.log(fooArr); // Uint8Array(3) [102, 111, 111]
console.log(fooResult); // { read: 3, written: 3 }

console.log(barArr); // Uint8Array(2) [98, 97]
console.log(barResult); // { read: 2, written: 2 }
```

`encode()` must allocate a new `Uint8Array`, whereas `encodeInto()` does not. For performance-sensitive applications, this distinction may have significant implications.

NOTE *Text encoding will always utilize the UTF-8 format and must write into a `Uint8Array` instance. Attempting to use a different typed array when calling `encodeInto()` will throw an error.*

Stream Encoding

A `TextEncoderStream` is merely a `TextEncoder` in the form of a `TransformStream`. Piping a decoded text stream through the stream encoder will yield a stream of encoded text chunks:

```
async function* chars() {
  const decodedText = 'foo';
```

```

    for (let char of decodedText) {
      yield await new Promise((resolve) => setTimeout(resolve, 1000, char));
    }
  }

  const decodedTextStream = new ReadableStream({
    async start(controller) {
      for await (let chunk of chars()) {
        controller.enqueue(chunk);
      }

      controller.close();
    }
  });

  const encodedTextStream = decodedTextStream.pipeThrough(new TextEncoderStream());

  const readableStreamDefaultReader = encodedTextStream.getReader();

  (async function() {
    while(true) {
      const { done, value } = await readableStreamDefaultReader.read();

      if (done) {
        break;
      } else {
        console.log(value);
      }
    }
  })();

  // Uint8Array[102]
  // Uint8Array[111]
  // Uint8Array[111]

```

Decoding Text

The Encoding API affords two ways of converting a typed array into its string equivalent: a *bulk* decoding, and a *stream* decoding. Unlike the encoder classes, when going from typed array to string, the decoder supports a large number of string encodings, listed here: <https://encoding.spec.whatwg.org/#names-and-labels>

The default character encoding is UTF-8.

Bulk Decoding

The *bulk* designation means that the JavaScript engine will synchronously decode the entire string. For very long strings, this can be a costly operation. Bulk decoding is accomplished using an instance of a `DecoderEncoder`:

```
const textDecoder = new TextDecoder();
```

This instance exposes a `decode()` method, which accepts a typed array and returns the decoded string:

```
const textDecoder = new TextDecoder();

// f encoded in utf-8 is 0x66 (102 in decimal)
// o encoded in utf-8 is 0x6F (111 in decimal)
const encodedText = Uint8Array.of(102, 111, 111);
const decodedText = textDecoder.decode(encodedText);

console.log(decodedText); // foo
```

The decoder does not care which typed array it is passed, so it will dutifully decode the entire binary representation. In this example, 32-bit values only containing 8-bit characters are decoded as UTF-8, yielding extra empty characters:

```
const textDecoder = new TextDecoder();

// f encoded in utf-8 is 0x66 (102 in decimal)
// o encoded in utf-8 is 0x6F (111 in decimal)
const encodedText = Uint32Array.of(102, 111, 111);
const decodedText = textDecoder.decode(encodedText);

console.log(decodedText); // "f  o  o  "
```

The decoder is equipped to handle characters that span multiple indices in the typed array, such as emojis:

```
const textDecoder = new TextDecoder();

// 🍌 encoded in UTF-8 is 0xF0 0x9F 0x98 0x8A (240, 159, 152, 138 in decimal)
const encodedText = Uint8Array.of(240, 159, 152, 138);
const decodedText = textDecoder.decode(encodedText);

console.log(decodedText); // 🍌
```

Unlike `TextEncoder`, `TextDecoder` is compatible with a wide number of character encodings. Consider the following example, which uses UTF-16 encoding instead of the default UTF-8:

```
const textDecoder = new TextDecoder('utf-16');

// f encoded in utf-8 is 0x0066 (102 in decimal)
// o encoded in utf-8 is 0x006F (111 in decimal)
const encodedText = Uint16Array.of(102, 111, 111);
const decodedText = textDecoder.decode(encodedText);

console.log(decodedText); // foo
```

Stream Decoding

A `TextDecoderStream` is merely a `TextDecoder` in the form of a `TransformStream`. Piping an encoded text stream through the stream decoder will yield a stream of decoded text chunks:

```
async function* chars() {
  // Each chunk must exist as a typed array
  const encodedText = [102, 111, 111].map(x => Uint8Array.of(x));
```

```

    for (let char of encodedText) {
      yield await new Promise((resolve) => setTimeout(resolve, 1000, char));
    }
  }

  const encodedTextStream = new ReadableStream({
    async start(controller) {
      for await (let chunk of chars()) {
        controller.enqueue(chunk);
      }

      controller.close();
    }
  });

  const decodedTextStream = encodedTextStream.pipeThrough(new TextDecoderStream());

  const readableStreamDefaultReader = decodedTextStream.getReader();

  (async function() {
    while(true) {
      const { done, value } = await readableStreamDefaultReader.read();

      if (done) {
        break;
      } else {
        console.log(value);
      }
    }
  })();

  // f
  // o
  // o

```

Text decoder streams implicitly understand that surrogate pairs may be split between chunks. The decoder stream will retain any fragmented chunks until a complete character is formed. Consider the following example, where the stream decoder will wait for all four chunks to be passed through before the decoded stream emits the single character:

```

async function* chars() {
  // ☺ encoded in UTF-8 is 0xF0 0x9F 0x98 0x8A (240, 159, 152, 138 in decimal)
  const encodedText = [240, 159, 152, 138].map((x) => Uint8Array.of(x));

  for (let char of encodedText) {
    yield await new Promise((resolve) => setTimeout(resolve, 1000, char));
  }
}

const encodedTextStream = new ReadableStream({
  async start(controller) {
    for await (let chunk of chars()) {
      controller.enqueue(chunk);
    }
  }
});

```

```
        controller.close();
    }
});

const decodedTextStream = encodedTextStream.pipeThrough(new TextDecoderStream());

const readableStreamDefaultReader = decodedTextStream.getReader();

(async function() {
    while(true) {
        const { done, value } = await readableStreamDefaultReader.read();

        if (done) {
            break;
        } else {
            console.log(value);
        }
    }
})();

// 😊
```

Text decoder streams will be most commonly used in conjunction with `fetch()`, as the response body can be processed as a `ReadableStream`. This might take the following form:

```
const response = await fetch(url);
const stream = response.body.pipeThrough(new TextDecoderStream());

for await (let decodedChunk of decodedStream) {
    console.log(decodedChunk);
}
```

BLOB AND FILE APIS

One of the major pain points of web applications has been the inability to interact with files on a user's computer. Since before 2000, the only way to deal with files was to place `<input type="file">` into a form and leave it at that. The Blob and File APIs are designed to give web developers access to files on the client computer in a secure manner that allows for better interaction with those files.

The File Type

The File API is still based around the file input field of a form but adds the ability to access the file information directly. HTML5 adds a `files` collection to DOM for the file input element. When one or more files are selected in the field, the `files` collection contains a sequence of `File` objects that represent each file. Each `File` object has several read-only properties, including:

- `name`—The file name on the local system.
- `size`—The size of the file in bytes.

- `type`—A string containing the MIME type of the file.
- `lastModifiedDate`—A string representing the last time the file was modified. This property has been implemented only in Chrome.

For instance, you can retrieve information about each file selected by listening for the `change` event and then looking at the `files` collection:

```
let fileList = document.getElementById("files-list");
fileList.addEventListener("change", (event) => {
  let files = event.target.files,
      i = 0,
      len = files.length;

  while (i < len) {
    const f = files[i];
    console.log(`${f.name} (${f.type}, ${f.size} bytes)`);
    i++;
  }
});
```

This example simply outputs the information about each file to the console. This capability alone is a big step forward for web applications, but the File API goes further by allowing you to actually read data from the files via the `FileReader` type.

The FileReader Type

The `FileReader` type represents an asynchronous file-reading mechanism. You can think of `FileReader` as similar to `XMLHttpRequest`, only it is used for reading files from the file system as opposed to reading data from the server. The `FileReader` type offers several methods to read in file data:

- `readAsText(file, encoding)`—Reads the file as plain text and stores the text in the `result` property. The second argument, the encoding type, is optional.
- `readAsDataURL(file)`—Reads the file and stores a data URI representing the files in the `result` property.
- `readAsBinaryString(file)`—Reads the file and stores a string where each character represents a byte in the `result` property.
- `readAsArrayBuffer(file)`—Reads the file and stores an `ArrayBuffer` containing the file contents in the `result` property.

These various ways of reading in a file allow for maximum flexibility in dealing with the file data. For instance, you may wish to read an image as a data URI in order to display it back to the user, or you may wish to read a file as text in order to parse it.

Because the read happens asynchronously, there are several events published by each `FileReader`. The three most useful events are `progress`, `error`, and `load`, which indicate when more data is available, when an error occurred, and when the file is fully read, respectively.

The `progress` event fires roughly every 50 milliseconds and has the same information available as the XHR `progress` event: `lengthComputable`, `loaded`, and `total`. Additionally, the `FileReader`'s `result` property is readable during the `progress` event even though it may not contain all of the data yet.

The `error` event fires if the file cannot be read for some reason. When the `error` event fires, the `error` property of the `FileReader` is filled in. This object has a single property, `code`, which is an error code of 1 (file not found), 2 (security error), 3 (read was aborted), 4 (file isn't readable), or 5 (encoding error).

The `load` event fires when the file has been successfully loaded; it will not fire if the `error` event has fired. Here's an example using all three events:

```
let filesList = document.getElementById("files-list");
filesList.addEventListener("change", (event) => {
  let info = "",
      output = document.getElementById("output"),
      progress = document.getElementById("progress"),
      files = event.target.files,
      type = "default",
      reader = new FileReader();

  if (/image/.test(files[0].type)) {
    reader.readAsDataURL(files[0]);
    type = "image";
  } else {
    reader.readAsText(files[0]);
    type = "text";
  }

  reader.onerror = function() {
    output.innerHTML = "Could not read file, error code is " +
      reader.error.code;
  };

  reader.onprogress = function(event) {
    if (event.lengthComputable) {
      progress.innerHTML = `${event.loaded}/${event.total}`;
    }
  };

  reader.onload = function() {
    let html = "";

    switch(type) {
      case "image":
        html = `
```

This code reads a file from a form field and displays it on the page. If the file has a MIME type indicating it's an image, then a data URI is requested and, upon `load`, this data URI is inserted as an image into the page. If the file is not an image, then it is read in as a string and output as is into the page. The `progress` event is used to track and display the bytes of data being read, while the `error` event watches for any errors.

You can stop a read in progress by calling the `abort()` method, in which case an `abort` event is fired. After the firing of `load`, `error`, or `abort`, an event called `loadend` is fired. The `loadend` event indicates that all reading has finished for any of the three reasons. The `readAsText()` and `readAsDataURL()` methods are supported across all implementing browsers.

The FileReaderSync Type

The `FileReaderSync` type, as its name suggests, is the *synchronous* version of `FileReader`. This features the same methods as `FileReader` but performs a blocking read of a file, only continuing execution after the entire file has been loaded into memory. `FileReaderSync` is only available inside of web workers, as the extremely slow process of reading an entire file would never be practical to use in the top-level execution environment.

Suppose a worker is sent a `File` object via `postMessage()`. The following code directs the worker to synchronously read the entire file into memory and send back the file's data URL:

```
// worker.js

self.omessage = (messageEvent) => {
  const syncReader = new FileReaderSync();
  console.log(syncReader); // FileReaderSync {}

  // Blocks worker thread while file is read
  const result = syncReader.readAsDataURL(messageEvent.data);

  // Example response for PDF file
  console.log(result); // data:application/pdf;base64,JVBERi0xLjQK...

  // Send URL back up
  self.postMessage(result);
};
```

Blobs and Partial Reads

In some cases, you may want to read only parts of a file instead of the whole file. To that end, the `File` object has a method called `slice()`. The `slice()` method accepts two arguments: the starting byte and the number of bytes to read. This method returns an instance of `Blob`, which is actually the super type of `File`.

A “blob,” short for *binary large object*, is a JavaScript wrapper for immutable binary data. Blobs can be created from an array containing strings, `ArrayBuffers`, `ArrayBufferViews`, or even other `Blobs`. The `Blob` constructor can optionally be provided a MIME type as part of its `options` parameter:

```
console.log(new Blob(['foo']));
// Blob {size: 3, type: ""}
```



```
console.log(new Blob(['{"a": "b"}'], { type: 'application/json' }));  
// {size: 10, type: "application/json"}  
  
console.log(new Blob(['<p>Foo</p>', '<p>Bar</p>'], { type: 'text/html' }));  
// {size: 20, type: "text/html"}
```

A `Blob` also has `size` and `type` properties, as well as the `slice()` method for further cutting down the data. You can read from a `Blob` by using a `FileReader` as well. This example reads just the first 32 bytes from a file:

```
let fileList = document.getElementById("files-list");  
fileList.addEventListener("change", (event) => {  
  let info = "",  
      output = document.getElementById("output"),  
      progress = document.getElementById("progress"),  
      files = event.target.files,  
      reader = new FileReader(),  
      blob = blobSlice(files[0], 0, 32);  
  if (blob) {  
    reader.readAsText(blob);  
  
    reader.onerror = function() {  
      output.innerHTML = "Could not read file, error code is " +  
        reader.error.code;  
    };  
    reader.onload = function() {  
      output.innerHTML = reader.result;  
    };  
  } else {  
    console.log("Your browser doesn't support slice().");  
  }  
});
```

Reading just parts of a file can save time, especially when you're just looking for a specific piece of data, such as a file header.

Object URLs and Blobs

Object URLs, also sometimes called *blob URLs*, are URLs that reference data stored in a `File` or `Blob`. The advantage of object URLs is that you don't need to read the file contents into JavaScript in order to use them. Instead, you simply provide the object URL in the appropriate place. To create an object URL, use the `window.URL.createObjectURL()` method and pass in the `File` or `Blob` object. The return value of this function is a string that points to a memory address. Because the string is a URL, it can be used in the DOM. For example, the following displays an image file on the page:

```
let fileList = document.getElementById("files-list");  
fileList.addEventListener("change", (event) => {  
  let info = "",  
      output = document.getElementById("output"),  
      progress = document.getElementById("progress"),  
      files = event.target.files,  
      reader = new FileReader(),  
      url = window.URL.createObjectURL(files[0]);  
  if (url) {
```

```

    if (/image/.test(files[0].type)) {
      output.innerHTML = `

```

By feeding the object URL directly into an `` tag, there is no need to read the data into JavaScript first. Instead, the `` tag goes directly to the memory location and reads the data into the page.

Once the data is no longer needed, it's best to free up the memory associated with it. Memory cannot be freed as long as an object URL is in use. You can indicate that the object URL is no longer needed by passing it to `window.URL.revokeObjectURL()`. All object URLs are freed from memory automatically when the page is unloaded. Still, it is best to free each object URL as it is no longer needed to ensure the memory footprint of the page remains as low as possible.

Drag-and-Drop File Reading

Combining the HTML5 Drag-and-Drop API with the File API allows you to create interesting interfaces for the reading of file information. After creating a custom drop target on a page, you can drag files from the desktop and drop them onto the drop target. This fires the `drop` event just like dragging and dropping an image or link would. The files being dropped are available on `event.dataTransfer.files`, which is a list of `File` objects just like those available on a file input field.

The following example prints out information about files that are dropped on a custom drop target in the page:

```

let droptarget = document.getElementById("droptarget");
function handleEvent(event) {
  let info = "",
      output = document.getElementById("output"),
      files, i, len;
  event.preventDefault();

  if (event.type == "drop") {
    files = event.dataTransfer.files;
    i = 0;
    len = files.length;

    while (i < len) {
      info += `${files[i].name} (${files[i].type}, ${files[i].size} bytes)<br>`;
      i++;
    }

    output.innerHTML = info;
  }
}
droptarget.addEventListener("dragenter", handleEvent);
droptarget.addEventListener("dragover", handleEvent);
droptarget.addEventListener("drop", handleEvent);

```

As with earlier drag-and-drop examples, you must cancel the default behavior of `dragenter`, `dragover`, and `drop`. During the `drop` event, the files become available on `event.dataTransfer.files`, and you can read their information at that time.

MEDIA ELEMENTS

With the explosive popularity of embedded audio and video on the Web, most content producers have been forced to use Flash for optimal cross-browser compatibility. HTML5 introduces two media-related elements to enable cross-browser audio and video embedding into a browser baseline without any plug-ins: `<audio>` and `<video>`.

Both of these elements allow web developers to easily embed media files into a page, as well as provide JavaScript hooks into common functionality, allowing custom controls to be created for the media. The elements are used as follows:

```
<!-- embed a video -->
<video src="conference.mpg" id="myVideo">Video player not available.</video>
<!-- embed an audio file -->
<audio src="song.mp3" id="myAudio">Audio player not available.</audio>
```

Each of these elements requires, at a minimum, the `src` attribute indicating the media file to load. You can also specify `width` and `height` attributes to indicate the intended dimensions of the video player and a `poster` attribute that is an image URI to display while the video content is being loaded. The `controls` attribute, if present, indicates that the browser should display a UI enabling the user to interact directly with the media. Any content between the opening and the closing tags is considered alternate content to display if the media player is unavailable.

You may optionally specify multiple different media sources because not all browsers support all media formats. To do so, omit the `src` attribute from the element and instead include one or more `<source>` elements, as in this example:

```
<!-- embed a video -->
<video id="myVideo">
  <source src="conference.webm" type="video/webm; codecs='vp8, vorbis'">
  <source src="conference.ogv" type="video/ogg; codecs='theora, vorbis'">
  <source src="conference.mpg">
  Video player not available.
</video>
<!-- embed an audio file -->
<audio id="myAudio">
  <source src="song.ogg" type="audio/ogg">
  <source src="song.mp3" type="audio/mpeg">
  Audio player not available.
</audio>
```

It's beyond the scope of this book to discuss the various codecs used with video and audio, but suffice to say that browsers support a varying range of codecs, so multiple source files are typically required.

Properties

The `<video>` and `<audio>` elements provide robust JavaScript interfaces. There are numerous properties shared by both elements that can be evaluated to determine the current state of the media, as described in the following table.

PROPERTY NAME	DATA TYPE	DESCRIPTION
<code>autoplay</code>	Boolean	Gets or sets the <code>autoplay</code> flag.
<code>buffered</code>	TimeRanges	An object indicating the buffered time ranges that have already been downloaded.
<code>bufferedBytes</code>	ByteRanges	An object indicating the buffered byte ranges that have already been downloaded.
<code>bufferingRate</code>	Integer	The average number of bits per second received from the download.
<code>bufferingThrottled</code>	Boolean	Indicates if the buffering has been throttled by the browser.
<code>controls</code>	Boolean	Gets or sets the <code>controls</code> attribute, which displays or hides the browser's built-in controls.
<code>currentLoop</code>	Integer	The number of loops that the media has played.
<code>currentSrc</code>	String	The URL for the currently playing media.
<code>currentTime</code>	Float	The number of seconds that have been played.
<code>defaultPlaybackRate</code>	Float	Gets or sets the default playback rate. By default, this is 1.0 seconds.
<code>duration</code>	Float	The total number of seconds for the media.
<code>ended</code>	Boolean	Indicates if the media has completely played.
<code>loop</code>	Boolean	Gets or sets whether the media should loop back to the start when finished.
<code>muted</code>	Boolean	Gets or sets if the media is muted.
<code>networkState</code>	Integer	Indicates the current state of the network connection for the media: 0 for empty, 1 for loading, 2 for loading meta data, 3 for loaded first frame, and 4 for loaded.

continues

TABLE (continued)

PROPERTY NAME	DATA TYPE	DESCRIPTION
<code>paused</code>	Boolean	Indicates if the player is paused.
<code>playbackRate</code>	Float	Gets or sets the current playback rate. This may be affected by the user causing the media to play faster or slower, unlike <code>defaultPlaybackRate</code> , which remains unchanged unless the developer changes it.
<code>played</code>	TimeRanges	The range of times that have been played thus far.
<code>readyState</code>	Integer	Indicates if the media is ready to be played. Values are 0 if the data is unavailable, 1 if the current frame can be displayed, 2 if the media can begin playing, and 3 if the media can play from beginning to end.
<code>seekable</code>	TimeRanges	The ranges of times that are available for seeking.
<code>seeking</code>	Boolean	Indicates that the player is moving to a new position in the media file.
<code>src</code>	String	The media file source. This can be rewritten at any time.
<code>start</code>	Float	Gets or sets the location in the media file, in seconds, where playing should begin.
<code>totalBytes</code>	Integer	The total number of bytes needed for the resource (if known).
<code>videoHeight</code>	Integer	Returns the height of the video (not necessarily of the element). Only for <code><video></code> .
<code>videoWidth</code>	Integer	Returns the width of the video (not necessarily of the element). Only for <code><video></code> .
<code>volume</code>	Float	Gets or sets the current volume as a value between 0.0 and 1.0.

Many of these properties can also be specified as attributes on either the `<audio>` or the `<video>` elements.

Events

In addition to the numerous properties, there are also numerous events that fire on these media elements. The events monitor all of the different properties that change because of media playback and user interaction with the player. These events are listed in the following table.

EVENT NAME	FIRES WHEN
<code>abort</code>	Downloading has been aborted.
<code>canplay</code>	Playback can begin; <code>readyState</code> is 2.
<code>canplaythrough</code>	Playback can proceed and should be uninterrupted; <code>readyState</code> is 3.
<code>canshowcurrentframe</code>	The current frame has been downloaded; <code>readyState</code> is 1.
<code>dataunavailable</code>	Playback can't happen because there's no data; <code>readyState</code> is 0.
<code>durationchange</code>	The <code>duration</code> property value has changed.
<code>emptied</code>	The network connection has been closed.
<code>empty</code>	An error occurs that prevents the media download.
<code>ended</code>	The media has played completely through and is stopped.
<code>error</code>	A network error occurred during download.
<code>load</code>	All of the media has been loaded. This event is considered deprecated; use <code>canplaythrough</code> instead.
<code>loadeddata</code>	The first frame for the media has been loaded.
<code>loadedmetadata</code>	The meta data for the media has been loaded.
<code>loadstart</code>	Downloading has begun.
<code>pause</code>	Playback has been paused.
<code>play</code>	The media has been requested to start playing.
<code>playing</code>	The media has actually started playing.
<code>progress</code>	Downloading is in progress.
<code>ratechange</code>	The speed at which the media is playing has changed.
<code>seeked</code>	Seeking has ended.
<code>seeking</code>	Playback is being moved to a new position.

continues

TABLE (continued)

EVENT NAME	FIRES WHEN
stalled	The browser is trying to download, but no data is being received.
timeupdate	The <code>currentTime</code> is updated in an irregular or unexpected way.
volumechange	The <code>volume</code> property value or <code>muted</code> property value has changed.
waiting	Playback is paused to download more data.

These events are designed to be as specific as possible to enable web developers to create custom audio/video players using little more than HTML and JavaScript (as opposed to creating a new Flash movie).

Custom Media Players

You can manually control the playback of a media file, using the `play()` and `pause()` methods that are available on both `<audio>` and `<video>`. Combining the properties, events, and these methods makes it easy to create a custom media player, as shown in this example:

```
<div class="mediaplayer">
  <div class="video">
    <video id="player" src="movie.mov" poster="mymovie.jpg"
      width="300" height="200">
      Video player not available.
    </video>
  </div>
  <div class="controls">
    <input type="button" value="Play" id="video-btn">
    <span id="curtime">0</span><span id="duration">0</span>
  </div>
</div>
```

This basic HTML can then be brought to life by using JavaScript to create a simple video player, as shown here:

```
// get references to the elements
let player = document.getElementById("player"),
    btn = document.getElementById("video-btn"),
    curtime = document.getElementById("curtime"),
    duration = document.getElementById("duration");
// update the duration
duration.innerHTML = player.duration;

// attach event handler to button
btn.addEventListener("click", (event) => {
  if (player.paused) {
    player.play();
    btn.value = "Pause";
  } else {
```

```

        player.pause();
        btn.value = "Play";
    }
});

// update the current time periodically
setInterval(() => {
    curtime.innerHTML = player.currentTime;
}, 250);

```

The JavaScript code here simply attaches an event handler to the button that either pauses or plays the video, depending on its current state. Then, an event handler is set for the `<video>` element's `load` event so that the duration can be displayed. Last, a repeating timer is set to update the current time display. You can extend the behavior of this custom video player by listening for more events and making use of more properties. The exact same code can also be used with the `<audio>` element to create a custom audio player.

Codec Support Detection

As mentioned previously, not all browsers support all codecs for `<video>` and `<audio>`, which frequently means you must provide more than one media source. There is also a JavaScript API for determining if a given format and codec is supported by the browser. Both media elements have a method called `canPlayType()`, which accepts a format/codecs string and returns a string value of "probably", "maybe", or "" (empty string). The empty string is a falsy value, which means you can still use `canPlayType()` in an `if` statement like this:

```

if (audio.canPlayType("audio/mpeg")) {
    // do something
}

```

Both "probably" and "maybe" are truthy values and so they get coerced to `true` within the context of an `if` statement.

When just a MIME type is provided to `canPlayType()`, the most likely return values are "maybe" and the empty string because a file is really just a container for audio or video data; it is the encoding that really determines if the file can be played. When both a MIME type and a codec are specified, you increase the likelihood of getting "probably" as the return value. Some examples:

```

let audio = document.getElementById("audio-player");
// most likely "maybe"
if (audio.canPlayType("audio/mpeg")) {
    // do something
}
// could be "probably"
if (audio.canPlayType("audio/ogg; codecs=\"vorbis\"")) {
    // do something
}

```

Note that the codecs list must always be enclosed in quotes to work properly. You can also detect video formats using `canPlayType()` on any video element.

The Audio Type

The `<audio>` element also has a native JavaScript constructor called `Audio` to allow the playing of audio at any point in time. The `Audio` type is similar to `Image` in that it is the equivalent of a DOM element but doesn't require insertion into the document to work. Just create a new instance and pass in the audio source file:

```
let audio = new Audio("sound.mp3");
EventUtil.addHandler(audio, "canplaythrough", function(event) {
    audio.play();
});
```

Creating a new instance of `Audio` begins the process of downloading the specified file. Once it's ready, you can call `play()` to start playing the audio.

Calling the `play()` method on iOS causes a dialog to pop up asking for the user's permission to play the sound. In order to play one sound after another, you must call `play()` immediately within the `onfinish` event handler.

NATIVE DRAG AND DROP

Internet Explorer 4 first introduced JavaScript support for drag-and-drop functionality for web pages. At the time, only two items on a web page could initiate a system drag: an image or some text. When dragging an image, you simply held the mouse button down and then moved it; with text, you first highlighted some text and then you could drag it the same way as you would drag an image. In Internet Explorer 4, the only valid drop target was a text box. In version 5, Internet Explorer extended its drag-and-drop capabilities by adding new events and allowing nearly anything on a web page to become a drop target. Version 5.5 went a little bit further by allowing nearly anything to become draggable. (Internet Explorer 6 supports this functionality as well.) HTML5 uses the Internet Explorer drag-and-drop implementation as the basis for its drag-and-drop specification. All major browsers have implemented native drag and drop according to the HTML5 spec.

Perhaps the most interesting thing about drag-and-drop support is that elements can be dragged across frames, browser windows, and sometimes, other applications. Drag-and-drop support in the browser allows you to tap into that functionality.

Drag-and-Drop Events

The events provided for drag and drop enable you to control nearly every aspect of a drag-and-drop operation. The tricky part is determining where each event is fired: some fire on the dragged item; others fire on the drop target. When an item is dragged, the following events fire (in this order):

1. `dragstart`
2. `drag`
3. `dragend`

At the moment you hold a mouse button down and begin to move the mouse, the `dragstart` event fires on the item that is being dragged. The cursor changes to the no-drop symbol (a circle with a line through it), indicating that the item cannot be dropped on itself. You can use the `ondragstart` event handler to run JavaScript code as the dragging begins.

After the `dragstart` event fires, the `drag` event fires and continues firing as long as the object is being dragged. This is similar to `mousemove`, which also fires repeatedly as the mouse is moved. When the dragging stops (because you drop the item onto either a valid or an invalid drop target), the `dragend` event fires.

The target of all three events is the element that is being dragged. By default, the browser does not change the appearance of the dragged element while a drag is happening, so it's up to you to change the appearance. Most browsers do, however, create a semitransparent clone of the element being dragged that always stays immediately under the cursor.

When an item is dragged over a valid drop target, the following sequence of events occurs:

1. `dragenter`
2. `dragover`
3. `dragleave` or `drop`

The `dragenter` event (similar to the `mouseover` event) fires as soon as the item is dragged over the drop target. Immediately after the `dragenter` event fires, the `dragover` event fires and continues to fire as the item is being dragged within the boundaries of the drop target. When the item is dragged outside of the drop target, `dragover` stops firing and the `dragleave` event is fired (similar to `mouseout`). If the dragged item is actually dropped on the target, the `drop` event fires instead of `dragleave`. The target of these events is the drop target element.

Custom Drop Targets

When you try to drag something over an invalid drop target, you see a special cursor (a circle with a line through it) indicating that you cannot drop. Even though all elements support the drop target events, the default is to not allow dropping. If you drag an element over something that doesn't allow a drop, the `drop` event will never fire regardless of the user action. However, you can turn any element into a valid drop target by overriding the default behavior of both the `dragenter` and the `dragover` events. For example, if you have a `<div>` element with an ID of `"droptarget"`, you can use the following code to turn it into a drop target:

```
let droptarget = document.getElementById("droptarget");

droptarget.addEventListener("dragover", (event) => {
  event.preventDefault();
});

droptarget.addEventListener("dragenter", (event) => {
  event.preventDefault();
});
```

After making these changes, you'll note that the cursor now indicates that a drop is allowed over the drop target when dragging an element. Also, the `drop` event will fire.

In Firefox, the default behavior for a drop event is to navigate to the URL that was dropped on the drop target. That means dropping an image onto the drop target will result in the page navigating to the image file, and text that is dropped on the drop target results in an invalid URL error. For Firefox support, you must also cancel the default behavior of the `drop` event to prevent this navigation from happening:

```
droptarget.addEventListener("drop", (event) => {
    event.preventDefault();
});
```

The `dataTransfer` Object

Simply dragging and dropping isn't of any use unless data is actually being affected. To aid in the transmission of data via a drag-and-drop operation, Internet Explorer 5 introduced the `dataTransfer` object, which exists as a property of `event` and is used to transfer string data from the dragged item to the drop target. Because it is a property of `event`, the `dataTransfer` object doesn't exist except within the scope of an event handler for a drag-and-drop event. Within an event handler, you can use the object's properties and methods to work with your drag-and-drop functionality. The `dataTransfer` object is now part of the working draft of HTML5.

The `dataTransfer` object has two primary methods: `getData()` and `setData()`. As you might expect, `getData()` is capable of retrieving a value stored by `setData()`. The first argument for `setData()`, and the only argument of `getData()`, is a string indicating the type of data being set: either `"text"` or `"URL"`, as shown here:

```
// working with text
event.dataTransfer.setData("text", "some text");
let text = event.dataTransfer.getData("text");

// working with a URL
event.dataTransfer.setData("URL", "http://www.wrox.com/");
let url = event.dataTransfer.getData("URL");
```

Even though Internet Explorer started out by introducing only `"text"` and `"URL"` as valid data types, HTML5 extends this to allow any MIME type to be specified. The values `"text"` and `"URL"` will be supported by HTML5 for backwards compatibility, but they are mapped to `"text/plain"` and `"text/uri-list"`.

The `dataTransfer` object can contain exactly one value of each MIME type, meaning that you can store both text and a URL at the same time without overwriting either. The data stored in the `dataTransfer` object is available only until the drop event. If you do not retrieve the data in the `ondrop` event handler, the `dataTransfer` object is destroyed and the data is lost.

When you drag text from a text box, the browser calls `setData()` and stores the dragged text in the `"text"` format. Likewise, when a link or image is dragged, `setData()` is called and the URL is stored. It is possible to retrieve these values when the data is dropped on a target by using `getData()`. You can also call `setData()` manually during the `dragstart` event to store custom data that you may want to retrieve later.

There is a difference between data treated as text and data treated as a URL. When you specify data to be stored as text, it gets no special treatment whatsoever. When you specify data to be stored as a URL, however, it is treated just like a link on a web page, meaning that if you drop it onto another browser window, the browser will navigate to that URL.

Firefox through version 5 doesn't properly alias "url" to "text/uri-list" or "text" to "text/plain". It does, however, alias "Text" (uppercase T) to "text/plain". For best cross-browser compatibility of retrieving data from `dataTransfer`, you'll need to check for two values for URLs and use "Text" for plain text:

```
let dataTransfer = event.dataTransfer;
// read a URL
let url = dataTransfer.getData("url") || dataTransfer.getData("text/uri-list");
// read text
let text = dataTransfer.getData("Text");
```

It's important that the shortened data name be tried first because Internet Explorer through version 10 doesn't support the extended names and also throws an error when the data name isn't recognized.

dropEffect and effectAllowed

The `dataTransfer` object can be used to do more than simply transport data to and fro; it can also be used to determine what type of actions can be done with the dragged item and the drop target. You accomplish this by using two properties: `dropEffect` and `effectAllowed`.

The `dropEffect` property is used to tell the browser which type of drop behaviors are allowed. This property has the following four possible values:

- "none"—A dragged item cannot be dropped here. This is the default value for everything except text boxes.
- "move"—The dragged item should be moved to the drop target.
- "copy"—The dragged item should be copied to the drop target.
- "link"—Indicates that the drop target will navigate to the dragged item (but only if it is a URL).

Each of these values causes a different cursor to be displayed when an item is dragged over the drop target. It is up to you, however, to actually cause the actions indicated by the cursor. In other words, nothing is automatically moved, copied, or linked without your direct intervention. The only thing you get for free is the cursor change. In order to use the `dropEffect` property, you must set it in the `ondragenter` event handler for the drop target.

The `dropEffect` property is useless, unless you also set the `effectAllowed`. This property indicates which `dropEffect` is allowed for the dragged item. The possible values are as follows:

- "uninitialized"—No action has been set for the dragged item.
- "none"—No action is allowed on the dragged item.
- "copy"—Only `dropEffect "copy"` is allowed.

- "link"—Only `dropEffect` "link" is allowed.
- "move"—Only `dropEffect` "move" is allowed.
- "copyLink"—`dropEffect` "copy" and "link" are allowed.
- "copyMove"—`dropEffect` "copy" and "move" are allowed.
- "linkMove"—`dropEffect` "link" and "move" are allowed.
- "all"—All `dropEffect` values are allowed.

This property must be set inside the `ondragstart` event handler.

Suppose that you want to allow a user to move text from a text box into a `<div>`. To accomplish this, you must set both `dropEffect` and `effectAllowed` to "move". The text won't automatically move itself because the default behavior for the drop event on a `<div>` is to do nothing. If you override the default behavior, the text is automatically removed from the text box. It is then up to you to insert it into the `<div>` to finish the action. If you were to change `dropEffect` and `effectAllowed` to "copy", the text in the text box would not automatically be removed.

Draggability

By default, images, links, and text are draggable, meaning that no additional code is necessary to allow a user to start dragging them. Text is draggable only after a section has been highlighted, while images and links may be dragged at any point in time.

It is possible to make other elements draggable. HTML5 specifies a `draggable` property on all HTML elements indicating if the element can be dragged. Images and links have `draggable` automatically set to `true`, whereas everything else has a default value of `false`. This property can be set in order to allow other elements to be draggable or to ensure that an image or link won't be draggable. For example:

```
<!-- turn off dragging for this image -->  
  
<!-- turn on dragging for this element -->  
<div draggable="true">...</div>
```

Additional Members

The HTML5 specification indicates the following additional methods on the `dataTransfer` object:

- `addElement(element)`—Adds an element to the drag operation. This is purely for data purposes and doesn't affect the appearance of the drag operation. As of the time of this writing, no browsers have implemented this method.
- `clearData(format)`—Clears the data being stored with the particular format.
- `setDragImage(element, x, y)`—Allows you to specify an image to be displayed under the cursor as the drag takes place. This method accepts three arguments: an HTML element to display and the `x`- and `y`-coordinates on the image where the cursor should be positioned.

The HTML element may be an image, in which case the image is displayed, or any other element, in which case a rendering of the element is displayed.

- `types`—A list of data types currently being stored. This collection acts like an array and stores the data types as strings such as "text".

NOTIFICATIONS API

The Notifications API, as its name suggests, is used to display notifications to the user. In many ways, notifications are similar to `alert()` dialog boxes: both use a JavaScript API to trigger browser behavior outside of the page itself, and both allow the page to handle the various ways in which users interact with the dialog boxes or notification tiles. Notifications, however, offer a far greater degree of customizability.

The Notifications API is especially useful in the context of service workers. It allows a progressive web application (PWA) to behave more like a native app by triggering notifications to show even when a browser page is not active.

Notification Permissions

The Notification API has the potential for abuse, so it enforces two security features by default:

- Notifications can be triggered only by code executing in a secure context.
- Notifications must be explicitly allowed by the user on a per-origin basis.

The user grants notification permission to an origin inside a browser dialog box. Unless the user declines to explicitly allow or deny permissions, this permission request can only happen a single time per domain: the browser will remember the user's choice, and if denied there is no redress.

The page can ask for notification permission using the `Notification` global object. This object features a `requestPermission()` method that returns a promise, which resolves when the user takes action on the permission dialog box.

```
Notification.requestPermission()
  .then((permission) => {
    console.log('User responded to permission request:', permission);
  });
```

A value of `granted` means the user explicitly granted permission to show notifications. Any other value indicates that attempts to show a notification will silently fail. If a user denies permission, the value will be `denied`. There is no programmatic redress for this, as it is not possible to re-trigger the permissions prompt.

Showing and Hiding Notification

The `Notification` constructor is used to create and show notifications. The simplest form of a notification is with only a title string that is passed as the first required parameter to the constructor. When the constructor is called in this way, the notification will display immediately:

```
new Notification('Title text!');
```

Notifications are highly customizable with the `options` parameter. Settings such as the notification body, image, and vibration are all controllable via this object:

```
new Notification('Title text!', {
  body: 'Body text!',
  image: 'path/to/image.png',
  vibrate: true
});
```

The `Notification` object returned from the constructor can be used to close an active notification using a `close()` method. The following example opens a notification and then closes it after 1000 milliseconds:

```
const n = new Notification('I will close in 1000ms');
setTimeout(() => n.close(), 1000);
```

Notification Lifecycle Callbacks

Notifications aren't always just for displaying text strings; they're also designed to be interactive. The Notification API offers four lifecycle hooks for attaching callbacks:

- `onshow` is triggered when the notification is displayed.
- `onclick` is triggered when the notification is clicked.
- `onclose` is triggered when the notification is dismissed or closed via `close()`.
- `onerror` is triggered when an error occurs that prevents the notification from being displayed.

The following notification logs a message upon each lifecycle event:

```
const n = new Notification('foo');

n.onshow = () => console.log('Notification was shown!');
n.onclick = () => console.log('Notification was clicked!');
n.onclose = () => console.log('Notification was closed!');
n.onerror = () => console.log('Notification experienced an error!');
```

PAGE VISIBILITY API

A major pain point for web developers is knowing when users are actually interacting with the page. If a page is minimized or hidden behind another tab, it may not make sense to continue functionality such as polling the server for updates or performing animations. The Page Visibility API aims to give developers information about whether or not the page is visible to the user.

The API itself is very simple, consisting of three parts:

- `document.visibilityState`—A value indicating one of four states:
 - The page is in a background tab or the browser is minimized.
 - The page is in the foreground tab.

- The actual page is hidden, but a preview of the page is visible (such as in Windows 7 when moving the mouse over an icon in the taskbar shows a preview).
- The page is being prerendered off-screen.
- `visibilitychange` event—This event fires when a document changes from hidden to visible, or vice versa.
- `document.hidden`—A Boolean value indicating if the page is hidden from view. This may mean the page is in a background tab or that the browser is minimized. This value is supported for backwards compatibility, you should use `document.visibilityState` to assess if the page is visible or not.

To be notified when the page changes from visible to hidden or hidden to visible, you can listen for the `visibilitychange` event.

`document.visibilityState` is one of three possible string values:

- `hidden`
- `visible`
- `prerender`

STREAMS API

The Streams API is the answer to a simple but fundamental question: *How can a web application consume information in sequential chunks rather than in bulk?* This capability is massively useful in two main ways:

- **A block of data may not be available all at once.** A perfect example of this is a response to a network request. Network payloads are delivered as a sequence of packets, and stream processing can allow an application to use network-delivered data as it becomes available rather than waiting for the full payload to finish loading.
- **A block of data can be processed in small portions.** Video processing, data decompression, image decoding, and JSON parsing are all examples of computation that is localized to a portion of a data block and does not require it to be in memory all at once.

The “Network Requests and Remote Resources” chapter covers how the Streams API is involved with `fetch()`, but the Streams API is totally generalizable. JavaScript libraries that implement Observables share many fundamental concepts with streams.

NOTE *Although the Fetch API is well-supported by major browsers, support for the Streams API lags behind considerably.*

Introduction to Streams

When thinking about streams, imagining the data as a liquid flowing through pipes is an apt mental framework. JavaScript streams borrow heavily from the plumbing lexicon due to their substantial conceptual overlap. Per the Streams specification, “These APIs have been designed to efficiently map to low-level I/O primitives, including specializations for byte streams where appropriate.” Two common tasks that the Stream API directly addresses are handling network requests and reading/writing to disk.

The Streams API features three types of streams:

- **Readable streams** are streams from which chunks can be read via a public interface. Data enters the stream internally from an *underlying source* and is processed by a *consumer*.
- **Writable streams** are streams to which chunks can be written via a public interface. A *producer* writes data into the stream, and that data is passed internally in an *underlying sink*.
- **Transform streams** are made up of two streams: a writable stream to accept input data (the *writable side*), and a readable stream to emit output data (the *readable side*). In between these two streams is the *transformer*, which can be used to inspect and modify the stream data as necessary.

Chunks, Internal Queues, and Backpressure

The fundamental unit in streams is the *chunk*. A chunk can be of any data type, but frequently it will take the form of a typed array. Each chunk is a discrete segment of the stream that can be handled in its entirety. Importantly, chunks do *not* have a fixed size or arrive at fixed intervals. In an *ideal* stream, chunks will generally be *approximately* the same size and arrive at *approximately* regular intervals, but any good stream implementation should be prepared to handle edge cases.

For all types of streams, there is a shared concept of an entrance and exit to the stream. There will sometimes be a mismatch between the rate of data entering and exiting the stream. This stream balance can take one of three forms:

- **The exit of the stream can process data faster than the data is provided at the entrance.** The stream exit will often be idle (which may indicate potential inefficiencies at the stream entrance), but there is little wasted memory or computation so this stream imbalance is acceptable.
- **The stream entrance and exit are in equilibrium.** This balance is ideal.
- **The entrance of the stream can provide data faster than the exit can process it.** This stream imbalance is inherently problematic. There will necessarily be a backlog of data somewhere, and streams must handle this accordingly.

Stream imbalance is a common problem, but streams are tooled to address it. All streams maintain an *internal queue* of chunks that have entered the stream but not yet exited. For a stream in equilibrium, the internal queue will consistently have zero or a small number of enqueued chunks because the stream exit is dequeuing chunks approximately as fast as they can be enqueued. The memory footprint of such a stream’s internal queue will remain relatively small.

When chunks are enqueued faster than they can be dequeued, the size of the internal queue will grow. The stream cannot allow its internal queue to grow indefinitely, so it uses *backpressure* to signal the stream entrance to stop sending data until the queue size returns below a predetermined threshold. This threshold is governed by a *queuing strategy* that defines the *high water mark*, the maximum memory footprint of the internal queue.

Readable Streams

Readable streams are a wrapper for an underlying source of data. This underlying source is able to feed its data into the stream and allow that data to be read from the stream's public interface.

Using the ReadableStreamDefaultController

Consider the following generator, which produces an incremented integer every 1000 milliseconds:

```
async function* ints() {
  // yield an incremented integer every 1000ms
  for (let i = 0; i < 5; ++i) {
    yield await new Promise((resolve) => setTimeout(resolve, 1000, i));
  }
}
```

These values can be passed into a readable stream via its controller. The simplest way to access a controller is by creating a new instance of a `ReadableStream`, defining a `start()` method inside the constructor's `underlyingSource` parameter, and using the `controller` parameter passed to that method. By default, the controller parameter is an instance of `ReadableStreamDefaultController`:

```
const readableStream = new ReadableStream({
  start(controller) {
    console.log(controller); // ReadableStreamDefaultController {}
  }
});
```

Use the `enqueue()` method to pass values into the controller. Once all the values have been passed, the stream is closed using `close()`:

```
async function* ints() {
  // yield an incremented integer every 1000ms
  for (let i = 0; i < 5; ++i) {
    yield await new Promise((resolve) => setTimeout(resolve, 1000, i));
  }
}

const readableStream = new ReadableStream({
  async start(controller) {
    for await (let chunk of ints()) {
      controller.enqueue(chunk);
    }

    controller.close();
  }
});
```

Using the ReadableStreamDefaultReader

This example so far successfully enqueues five values in the stream, but there is nothing reading them out of that queue. To do so, a `ReadableStreamDefaultReader` instance can be acquired from the stream with `getReader()`. This will obtain a lock on the stream, ensuring only this reader can read values from that stream:

```
async function* ints() {
  // yield an incremented integer every 1000ms
  for (let i = 0; i < 5; ++i) {
    yield await new Promise((resolve) => setTimeout(resolve, 1000, i));
  }
}

const readableStream = new ReadableStream({
  async start(controller) {
    for await (let chunk of ints()) {
      controller.enqueue(chunk);
    }

    controller.close();
  }
});

console.log(readableStream.locked); // false
const readableStreamDefaultReader = readableStream.getReader();
console.log(readableStream.locked); // true
```

A consumer can get values from this reader instance using its `read()` method:

```
async function* ints() {
  // yield an incremented integer every 1000ms
  for (let i = 0; i < 5; ++i) {
    yield await new Promise((resolve) => setTimeout(resolve, 1000, i));
  }
}

const readableStream = new ReadableStream({
  async start(controller) {
    for await (let chunk of ints()) {
      controller.enqueue(chunk);
    }

    controller.close();
  }
});

console.log(readableStream.locked); // false
const readableStreamDefaultReader = readableStream.getReader();
console.log(readableStream.locked); // true

// Consumer
(async function() {
  while(true) {
    const { done, value } = await readableStreamDefaultReader.read();
```

```

        if (done) {
            break;
        } else {
            console.log(value);
        }
    }
}()

// 0
// 1
// 2
// 3
// 4

```

Writable Streams

Writable streams are a wrapper for an underlying sink for data. This underlying sink handles data from the stream's public interface.

Creating a WritableStream

Consider the following generator, which produces an incremented integer every 1000 milliseconds:

```

async function* ints() {
    // yield an incremented integer every 1000ms
    for (let i = 0; i < 5; ++i) {
        yield await new Promise((resolve) => setTimeout(resolve, 1000, i));
    }
}

```

These values can be written to a writable stream via its public interface. When the public `write()` method is invoked, the `write()` method defined on the `underlyingSink` object passed to the constructor is also called:

```

const readableStream = new ReadableStream({
    write(value) {
        console.log(value);
    }
});

```

Using a WritableStreamDefaultWriter

To write values to this stream, a `WritableStreamDefaultWriter` instance can be acquired from the stream with `getWriter()`. This will obtain a lock on the stream, ensuring only this writer can write values to that stream:

```

async function* ints() {
    // yield an incremented integer every 1000ms
    for (let i = 0; i < 5; ++i) {
        yield await new Promise((resolve) => setTimeout(resolve, 1000, i));
    }
}

const writableStream = new WritableStream({

```

```
    write(value) {
      console.log(value);
    }
  });

  console.log(writableStream.locked); // false
  const writableStreamDefaultWriter = writableStream.getWriter();
  console.log(writableStream.locked); // true
```

Before writing values to the stream, the producer must ensure the writer is capable of accepting values. `WritableStreamDefaultWriter.ready` returns a promise that resolves when the writer is ready for writing values to the stream. Following this, values can be passed with `write()` until the data stream is complete, at which point the stream can be terminated with `close()`:

```
async function* ints() {
  // yield an incremented integer every 1000ms
  for (let i = 0; i < 5; ++i) {
    yield await new Promise((resolve) => setTimeout(resolve, 1000, i));
  }
}

const writableStream = new WritableStream({
  write(value) {
    console.log(value);
  }
});

console.log(writableStream.locked); // false
const writableStreamDefaultWriter = writableStream.getWriter();
console.log(writableStream.locked); // true

// Producer
(async function() {
  for await (let chunk of ints()) {
    await writableStreamDefaultWriter.ready;
    writableStreamDefaultWriter.write(chunk);
  }

  writableStreamDefaultWriter.close();
})();
```

Transform Streams

Transform streams combine both a readable stream and a writable stream. In between the two streams is the `transform()` method, which is the intermediate point at which the chunk transformation occurs.

Consider the following generator, which produces an incremented integer every 1000 milliseconds:

```
async function* ints() {
  // yield an incremented integer every 1000ms
  for (let i = 0; i < 5; ++i) {
    yield await new Promise((resolve) => setTimeout(resolve, 1000, i));
  }
}
```

A `TransformStream`, which doubles the values emitted from this generator, can be defined as follows:

```

async function* ints() {
  // yield an incremented integer every 1000ms
  for (let i = 0; i < 5; ++i) {
    yield await new Promise((resolve) => setTimeout(resolve, 1000, i));
  }
}

const { writable, readable } = new TransformStream({
  transform(chunk, controller) {
    controller.enqueue(chunk * 2);
  }
});

```

Passing data into and pulling data out of the transform stream's component streams can be accomplished identically to the previous readable stream and writable stream sections of this chapter:

```

async function* ints() {
  // yield an incremented integer every 1000ms
  for (let i = 0; i < 5; ++i) {
    yield await new Promise((resolve) => setTimeout(resolve, 1000, i));
  }
}

const { writable, readable } = new TransformStream({
  transform(chunk, controller) {
    controller.enqueue(chunk * 2);
  }
});

const readableStreamDefaultReader = readable.getReader();
const writableStreamDefaultWriter = writable.getWriter();

// Consumer
(async function() {
  while (true) {
    const { done, value } = await readableStreamDefaultReader.read();

    if (done) {
      break;
    } else {
      console.log(value);
    }
  }
})();

// Producer
(async function() {
  for await (let chunk of ints()) {
    await writableStreamDefaultWriter.ready;
    writableStreamDefaultWriter.write(chunk);
  }

  writableStreamDefaultWriter.close();
})();

```

Piping Streams

Streams can be piped into one another to form a chain. One common form of this is to pipe a `ReadableStream` into a `TransformStream` using the `pipeThrough()` method. Internally, the initial `ReadableStream` passes its values into the `TransformStream`'s internal `WritableStream`, the stream performs the transformation, and the transformed values emerge from the new `ReadableStream` endpoint. Consider the following example where a `ReadableStream` of integers is passed through a `TransformStream` that doubles each value:

```
async function* ints() {
  // yield an incremented integer every 1000ms
  for (let i = 0; i < 5; ++i) {
    yield await new Promise((resolve) => setTimeout(resolve, 1000, i));
  }
}

const integerStream = new ReadableStream({
  async start(controller) {
    for await (let chunk of ints()) {
      controller.enqueue(chunk);
    }

    controller.close();
  }
});

const doublingStream = new TransformStream({
  transform(chunk, controller) {
    controller.enqueue(chunk * 2);
  }
});

// Perform stream piping
const pipedStream = integerStream.pipeThrough(doublingStream);

// Acquire reader on output of piped streams
const pipedStreamDefaultReader = pipedStream.getReader();

// Consumer
(async function() {
  while(true) {
    const { done, value } = await pipedStreamDefaultReader.read();

    if (done) {
      break;
    } else {
      console.log(value);
    }
  }
})();
```

```
// 0
// 2
// 4
// 6
// 8
```

It's also possible to pipe a `ReadableStream` to a `WritableStream` using the `pipeTo()` method. This behaves in a similar fashion to `pipeThrough()`:

```
async function* ints() {
  // yield an incremented integer every 1000ms
  for (let i = 0; i < 5; ++i) {
    yield await new Promise((resolve) => setTimeout(resolve, 1000, i));
  }
}

const integerStream = new ReadableStream({
  async start(controller) {
    for await (let chunk of ints()) {
      controller.enqueue(chunk);
    }

    controller.close();
  }
});

const writableStream = new WritableStream({
  write(value) {
    console.log(value);
  }
});

const pipedStream = integerStream.pipeTo(writableStream);

// 0
// 1
// 2
// 3
// 4
```

Notice here that the piping operation is implicitly acquiring a reader from the `ReadableStream` and feeding the produced values into the `WritableStream`.

TIMING APIS

Page performance is always an area of concern for web developers. The Performance interface changes that by exposing internal browser metrics through a JavaScript API, allowing developers to directly access this information and do as they please with it. This interface is available through the `window.performance` object. All metrics related to the page, both those already defined and those in the future, exist on this object.

The performance interface is composed of a number of APIs, most of which have two specification levels:

- **High Resolution Time API**
 - Level 1: <https://www.w3.org/TR/hr-time-1/#dom-performance-now>
 - Level 2: <https://www.w3.org/TR/hr-time/>
- **Performance Timeline API**
 - Level 1: <https://www.w3.org/TR/performance-timeline/#sec-window.performance-attribute>
 - Level 2: <https://w3c.github.io/performance-timeline/#extensions-to-the-performance-interface>
- **Navigation Timing API**
 - Level 1: <https://www.w3.org/TR/navigation-timing/>
 - Level 2: <https://w3c.github.io/navigation-timing/>
- **User Timing API**
 - Level 1: <https://www.w3.org/TR/user-timing/#extensions-performance-interface>
 - Level 2: <https://w3c.github.io/user-timing/#extensions-performance-interface>
- **Resource Timing API**
 - Level 1: <https://www.w3.org/TR/resource-timing-1/#extensions-performance-interface>
 - Level 2: <https://www.w3.org/TR/resource-timing-2/#extensions-performance-interface>
- **Paint Timing API**
 - <https://w3c.github.io/paint-timing/#sec-PerformancePaintTiming>

NOTE *Browsers will generally support the deprecated version 1 and the replacement version 2. This section focuses on the Level 2 specification where applicable.*

High Resolution Time API

The `Date.now()` method is only useful for datetime operations, which do not require precision timekeeping. In the following example, a timestamp is captured before and after a function `foo()` is invoked:

```
const t0 = Date.now();
foo();
const t1 = Date.now();
```

```
const duration = t1 - t0;

console.log(duration);
```

Consider the following scenarios where `duration` has an unexpected value:

- **duration is 0.** `Date.now()` only has millisecond precision, and both timestamps will capture the same value if `foo()` executes quickly enough.
- **duration is negative or enormous.** If the system clock is adjusted backwards or forwards while `foo()` executes (such as during daylight saving time), the captured timestamps will not account for this and the difference will incorporate the adjustment.

For these reasons, a different time measurement API must be used to precisely and accurately measure the passage of time. To address these needs, the High Resolution Time API defines `window.performance.now()`, which returns a floating point number with up to microsecond precision. As a result, it is much more unlikely to sequentially capture timestamps and have them be identical. This method also guarantees monotonically increasing timestamps.

```
const t0 = performance.now();
const t1 = performance.now();

console.log(t0);           // 1768.625000026077
console.log(t1);           // 1768.6300000059418

const duration = t1 - t0;

console.log(duration);     // 0.004999979864805937
```

The `performance.now()` timer is a *relative* measurement. It begins counting at 0 when its execution context is spawned: for example, when a page is opened or when a worker is created. Because the timer initialization will be offset between contexts, direct comparison of `performance.now()` values across execution contexts is not possible without a shared reference point. The `performance.timeOrigin` property returns the global system clock's value when the timer initialization occurred.

```
const relativeTimestamp = performance.now();

const absoluteTimestamp = performance.timeOrigin + relativeTimestamp;

console.log(relativeTimestamp); // 244.43500000052154
console.log(absoluteTimestamp); // 1561926208892.4001
```

NOTE Security exploits such as Spectre can perform cache inference attacks by using `performance.now()` to measure the latency delta between the L1 cache and main memory. To address this vulnerability, all major browsers have either reduced the precision of `performance.now()` or incorporated some randomness into the timestamp. The WebKit blog has an excellent article on this topic at <https://webkit.org/blog/8048/what-spectre-and-meltdown-mean-for-webkit/>.

Performance Timeline API

The Performance Timeline API extends the Performance interface with a suite of tools intended to measure client-side latency. Performance measurements will almost always take the form of calculating the difference between an end and a start time. These start and end times are recorded as `DOM-HighResTimeStamp` values, and the objects that wrap these timestamps are `PerformanceEntry` instances.

The browser automatically records a variety of different `PerformanceEntry` objects, and it is also possible to record your own with `performance.mark()`. All recorded entries recorded in an execution context can be accessed using `performance.getEntries()`:

```
console.log(performance.getEntries());  
  
// [PerformanceNavigationTiming, PerformanceResourceTiming, ... ]
```

This collection represents the browser's *performance timeline*. Every `PerformanceEntry` object features a `name`, `entryType`, `startTime`, and `duration` property:

```
const entry = performance.getEntries()[0];  
  
console.log(entry.name);      // "https://foo.com"  
console.log(entry.entryType); // navigation  
console.log(entry.startTime); // 0  
console.log(entry.duration);  // 182.36500001512468
```

However, `PerformanceEntry` is effectively an abstract base class, as recorded entries will always inherit from `PerformanceEntry` but ultimately exist as one of the following classes:

- `PerformanceMark`
- `PerformanceMeasure`
- `PerformanceFrameTiming`
- `PerformanceNavigationTiming`
- `PerformanceResourceTiming`
- `PerformancePaintTiming`

Each of these types adds a *substantial* number of properties that describe metadata involving what the entry represents. The `name` and `entryType` property for an instance will differ based on its type.

User Timing API

The User Timing API allows you to record and analyze custom performance entries. Recording a custom performance entry is accomplished with `performance.mark()`:

```
performance.mark('foo');  
  
console.log(performance.getEntriesByType('mark')[0]);  
// PerformanceMark {  
//   name: "foo",  
//   entryType: "mark",
```

```
//   startTime: 269.8800000362098,
//   duration: 0
// }
```

Creating two performance entries on either side of the computation allows you to calculate the time delta. The newest marks are pushed onto the beginning of the array returned from `getEntriesByType()`:

```
performance.mark('foo');
for (let i = 0; i < 1E6; ++i) {}
performance.mark('bar');

const [endMark, startMark] = performance.getEntriesByType('mark');
console.log(startMark.startTime - endMark.startTime); // 1.3299999991431832
```

It's also possible to generate a `PerformanceMeasure` entry that corresponds to the duration of time between two marks identified via their name. This is accomplished with `performance.measure()`:

```
performance.mark('foo');
for (let i = 0; i < 1E6; ++i) {}
performance.mark('bar');

performance.measure('baz', 'foo', 'bar');

const [differenceMark] = performance.getEntriesByType('measure');

console.log(differenceMark);
// PerformanceMeasure {
//   name: "baz",
//   entryType: "measure",
//   startTime: 298.9800000214018,
//   duration: 1.349999976810068
// }
```

Navigation Timing API

The Navigation Timing API offers high-precision timestamps for metrics covering how quickly the current page loaded. The browser automatically records a `PerformanceNavigationTiming` entry when a navigation event occurs. This object captures a broad range of timestamps describing how and when the page loaded.

The following example calculates the amount of time between the `loadEventStart` and `loadEventEnd` timestamps:

```
const [performanceNavigationTimingEntry] = performance.getEntriesByType('navigation');

console.log(performanceNavigationTimingEntry);
// PerformanceNavigationTiming {
//   connectEnd: 2.259999979287386
//   connectStart: 2.259999979287386
//   decodedBodySize: 122314
//   domComplete: 631.9899999652989
//   domContentLoadedEventEnd: 300.92499998863786
//   domContentLoadedEventStart: 298.8950000144541
```

```
//   domInteractive: 298.88499999651685
//   domainLookupEnd: 2.259999979287386
//   domainLookupStart: 2.259999979287386
//   duration: 632.819999998901
//   encodedBodySize: 21107
//   entryType: "navigation"
//   fetchStart: 2.259999979287386
//   initiatorType: "navigation"
//   loadEventEnd: 632.819999998901
//   loadEventStart: 632.0149999810383
//   name: "https://foo.com"
//   nextHopProtocol: "h2"
//   redirectCount: 0
//   redirectEnd: 0
//   redirectStart: 0
//   requestStart: 7.7099999762140214
//   responseEnd: 130.50999998813495
//   responseStart: 127.16999999247491
//   secureConnectionStart: 0
//   serverTiming: []
//   startTime: 0
//   transferSize: 21806
//   type: "navigate"
//   unloadEventEnd: 132.73999997181818
//   unloadEventStart: 132.41999997990206
//   workerStart: 0
// }

console.log(performanceNavigationTimingEntry.loadEventEnd -
            performanceNavigationTimingEntry.loadEventStart);
// 0.805000017862767
```

Resource Timing API

The Resource Timing API offers high-precision timestamps for metrics covering how quickly resources requested for the current page loaded. The browser automatically records a `PerformanceResourceTiming` entry when an asset is loaded. This object captures a broad range of timestamps describing how quickly that resource loaded.

The following example calculates the amount of time it took to load a specific resource:

```
const performanceResourceTimingEntry = performance.getEntriesByType('resource')[0];

console.log(performanceResourceTimingEntry);
// PerformanceResourceTiming {
//   connectEnd: 138.11499997973442
//   connectStart: 138.11499997973442
//   decodedBodySize: 33808
//   domainLookupEnd: 138.11499997973442
//   domainLookupStart: 138.11499997973442
//   duration: 0
//   encodedBodySize: 33808
//   entryType: "resource"
//   fetchStart: 138.11499997973442
```

```

// initiatorType: "link"
// name: "https://static.foo.com/bar.png",
// nextHopProtocol: "h2"
// redirectEnd: 0
// redirectStart: 0
// requestStart: 138.11499997973442
// responseEnd: 138.11499997973442
// responseStart: 138.11499997973442
// secureConnectionStart: 0
// serverTiming: []
// startTime: 138.11499997973442
// transferSize: 0
// workerStart: 0
// }

console.log(performanceResourceTimingEntry.responseEnd -
            performanceResourceTimingEntry.requestStart);
// 493.9600000507198

```

Using the difference between various times can give you a good idea about how a page is being loaded into the browser and where the potential bottlenecks are hiding.

WEB COMPONENTS

The term "web components" refers to a handful of tools designed to enhance DOM behavior: shadow DOM, custom elements, and HTML templates. This collection of browser APIs is particularly messy:

- There is no single "Web Components" specification: each web component is defined in a different specification.
- Several web components, such as shadow DOM and custom elements, have undergone backwards-incompatible versioning.
- Adoption across browser vendors is extremely inconsistent.

Because of these issues, adopting web components often demands a web component library, such as Polymer (<https://www.polymer-project.org/>), to polyfill and emulate missing web components in the browser.

NOTE *This chapter covers only the latest versions of web components.*

HTML Templates

Before web components, there wasn't a particularly good way of writing HTML that would allow the browser to build a DOM subtree from parsed HTML but decline to render that subtree until instructed to do so. One workaround was to use `innerHTML` to convert a markup string into DOM elements, but this strategy has serious security implications. Another workaround was to

construct each element using `document.createElement()` and progressively attach them to an orphaned root node (not attached to the DOM), but doing so is quite laborious and circumnavigates using markup at all.

Instead, it would be far better to write special markup in the page that the browser automatically parses into a DOM subtree but skips rendering. This is the core idea of HTML templates, which use the `<template>` tag for precisely this purpose. A simple example of an HTML template is as follows:

```
<template id="foo">
  <p>I'm inside a template!</p>
</template>
```

Using a DocumentFragment

When rendered inside a browser, you will not see this text render on the page. Because the `<template>` content is not considered part of the active document, DOM matching methods such as `document.querySelector()` will be unable to find the `<p>` tag. This is because it exists inside a new Node subclass added as part of HTML templates: the `DocumentFragment`.

The `DocumentFragment` inside a `<template>` is visible when inspecting inside the browser:

```
<template id="foo">
  #document-fragment
  <p>I'm inside a template!</p>
</template>
```

A reference to this `DocumentFragment` can be retrieved via the `content` property of the `<template>` element:

```
console.log(document.querySelector('#foo').content); // #document-fragment
```

The `DocumentFragment` behaves as a minimal document object for that subtree. For example, DOM matching methods on a `DocumentFragment` *can* find nodes in its subtree:

```
const fragment = document.querySelector('#foo').content;

console.log(document.querySelector('p')); // null
console.log(fragment.querySelector('p')); // <p>...<p>
```

A `DocumentFragment` is also incredibly useful for adding HTML in bulk. Consider a scenario where one wishes to add multiple children to an HTML element as efficiently as possible. Using consecutive `document.appendChild()` calls for each child is painstaking and can potentially incur multiple reflows. Using a `DocumentFragment` allows for you to batch these child additions, guaranteeing at most a single reflow:

```
// Start state:
// <div id="foo"></div>
//
// Desired end state:
// <div id="foo">
//   <p></p>
//   <p></p>
//   <p></p>
// </div>
```

```

// Also can use document.createDocumentFragment()
const fragment = new DocumentFragment();

const foo = document.querySelector('#foo');

// Adding children to a DocumentFragment incurs no reflow
fragment.appendChild(document.createElement('p'));
fragment.appendChild(document.createElement('p'));
fragment.appendChild(document.createElement('p'));

console.log(fragment.children.length); // 3

foo.appendChild(fragment);

console.log(fragment.children.length); // 0

console.log(document.body.innerHTML);
// <div id="foo">
//   <p></p>
//   <p></p>
//   <p></p>
// </div>

```

Using <template> tags

Notice in the previous example how the child nodes of the `DocumentFragment` are effectively transferred onto the `foo` element, leaving the `DocumentFragment` empty. This same procedure can be replicated using a `<template>`:

```

const fooElement = document.querySelector('#foo');
const barTemplate = document.querySelector('#bar');
const barFragment = barTemplate.content;

console.log(document.body.innerHTML);
// <div id="foo">
// </div>
// <template id="bar">
//   <p></p>
//   <p></p>
//   <p></p>
// </template>

fooElement.appendChild(barFragment);

console.log(document.body.innerHTML);
// <div id="foo">
//   <p></p>
//   <p></p>
//   <p></p>
// </div>
// <template id="bar"></template>

```

If you wish to instead copy the template, a simple `importNode()` can be used to clone the `DocumentFragment`:

```
const fooElement = document.querySelector('#foo');
const barTemplate = document.querySelector('#bar');
const barFragment = barTemplate.content;

console.log(document.body.innerHTML);
// <div id="foo">
// </div>
// <template id="bar">
//   <p></p>
//   <p></p>
//   <p></p>
// </template>

fooElement.appendChild(document.importNode(barFragment, true));

console.log(document.body.innerHTML);
// <div id="foo">
//   <p></p>
//   <p></p>
//   <p></p>
// </div>
// <template id="bar">
//   <p></p>
//   <p></p>
//   <p></p>
// </template>
```

Template Scripts

Script execution will be deferred until the `DocumentFragment` is added to the real DOM tree. This is demonstrated here:

```
// Page HTML:
//
// <div id="foo"></div>
// <template id="bar">
//   <script>console.log('Template script executed');</script>
// </template>

const fooElement = document.querySelector('#foo');
const barTemplate = document.querySelector('#bar');
const barFragment = barTemplate.content;

console.log('About to add template');
fooElement.appendChild(barFragment);
console.log('Added template');

// About to add template
// Template script executed
// Added template
```

This is useful in situations where addition of the new elements requires some initialization.

Shadow DOM

Conceptually, the shadow DOM web component is fairly straightforward: It allows you to attach an entirely separate DOM tree as a node on a parent DOM tree. This allows for DOM encapsulation, meaning that things like CSS styling and CSS selectors can be restricted to a shadow DOM subtree instead of the entire top-level DOM tree.

Shadow DOM is similar to HTML templates in that both are a `document`-like structure that enables a degree of separation from the top-level DOM. However, shadow DOM is distinct from HTML templates in that shadow DOM content is actually rendered on the page, whereas HTML template content is not.

Introduction to Shadow DOM

Consider a scenario where you have multiple similarly structured DOM subtrees:

```
<div>
  <p>Make me red!</p>
</div>
<div>
  <p>Make me blue!</p>
</div>
<div>
  <p>Make me green!</p>
</div>
```

As you've likely surmised from the text nodes, each of these three DOM subtrees should be assigned different colors. Normally, in order to apply a style uniquely to each of these without resorting to the `style` attribute, you'd likely apply a unique class name to each subtree and define the styling inside a corresponding selector:

```
<div class="red-text">
  <p>Make me red!</p>
</div>
<div class="green-text">
  <p>Make me green!</p>
</div>
<div class="blue-text">
  <p>Make me blue!</p>
</div>

<style>
  .red-text {
    color: red;
  }
  .green-text {
    color: green;
  }
  .blue-text {
    color: blue;
  }
</style>
```

Of course, this is a less than ideal solution. This isn't much different than defining variables in a global namespace; this CSS will be applied to the entire DOM even though you know with certainty that these style definitions are not needed anywhere else. You could keep adding CSS selector specificity to prevent these styles from bleeding elsewhere, but this is little more than a half-measure. Ideally, you'd prefer to restrict CSS to only a portion of the DOM: therein lies the raw utility of the shadow DOM.

Creating a Shadow DOM

For reasons involving security or preventing shadow DOM collisions, not all element types can have a shadow DOM attached to them. Attempting to attach a shadow DOM to an invalid element type, or an element with a shadow DOM already attached, will throw an error.

The following is a list of elements capable of hosting a shadow DOM:

- Any autonomous custom element with a valid name (as defined in the HTML specification: <https://html.spec.whatwg.org/multipage/custom-elements.html#valid-custom-element-name>)
- `<article>`
- `<aside>`
- `<blockquote>`
- `<body>`
- `<div>`
- `<footer>`
- `<h1>`
- `<h2>`
- `<h3>`
- `<h4>`
- `<h5>`
- `<h6>`
- `<header>`
- `<main>`
- `<nav>`
- `<p>`
- `<section>`
- ``

A shadow DOM is created by attaching it to a valid HTML element using the `attachShadow()` method. The element to which a shadow DOM is attached is referred to as the *shadow host*. The root node of the shadow DOM is referred to as the *shadow root*.

The `attachShadow()` method expects a required `shadowRootInit` object and returns the instance of the shadow DOM. The `shadowRootInit` object must contain a single `mode` property specifying either "open" or "closed". A reference to an open shadow DOM can be obtained on an HTML element via the `shadowRoot` property; this is not possible with a closed shadow DOM.

The mode difference is demonstrated here:

```
document.body.innerHTML = `
  <div id="foo"></div>
  <div id="bar"></div>
`;

const foo = document.querySelector('#foo');
const bar = document.querySelector('#bar');

const openShadowDOM = foo.attachShadow({ mode: 'open' });
const closedShadowDOM = bar.attachShadow({ mode: 'closed' });

console.log(openShadowDOM); // #shadow-root (open)
console.log(closedShadowDOM); // #shadow-root (closed)

console.log(foo.shadowRoot); // #shadow-root (open)
console.log(bar.shadowRoot); // null
```

In general, there is rarely a situation in which creating a closed shadow DOM is necessary. Although it confers the ability to restrict programmatic access to a shadow DOM from the shadow host, there are plenty of ways for malicious code to circumnavigate this and regain access to the shadow DOM. In short, creating a closed shadow DOM should *not* be used for security purposes.

NOTE *If you wish to protect a separate DOM tree from untrusted code, a shadow DOM is unsuitable for such a requirement. The cross-origin restrictions enforced on an `<iframe>` are much more robust.*

Using a Shadow DOM

Once attached to an element, a shadow DOM can be used as a normal DOM. Consider the following example, which recreates the red/green/blue example shown previously:

```
for (let color of ['red', 'green', 'blue']) {
  const div = document.createElement('div');
  const shadowDOM = div.attachShadow({ mode: 'open' });

  document.body.appendChild(div);
```

```
shadowDOM.innerHTML = `  
  <p>Make me ${color}</p>  
  
  <style>  
  p {  
    color: ${color};  
  }  
  </style>  
`;  
}
```

Although there are three identical selectors applying three different colors, the selectors will only be applied to the shadow DOM in which they are defined. As such, the three `<p>` elements will appear in three different colors.

You can verify that these elements exist inside their own shadow DOM as follows:

```
for (let color of ['red', 'green', 'blue']) {  
  const div = document.createElement('div');  
  const shadowDOM = div.attachShadow({ mode: 'open' });  
  
  document.body.appendChild(div);  
  
  shadowDOM.innerHTML = `  
    <p>Make me ${color}</p>  
  
    <style>  
    p {  
      color: ${color};  
    }  
    </style>  
  `;  
}  
  
function countP(node) {  
  console.log(node.querySelectorAll('p').length);  
}  
  
countP(document); // 0  
  
for (let element of document.querySelectorAll('div')) {  
  countP(element.shadowRoot);  
}  
  
// 1  
// 1  
// 1
```

Browser inspector tools will make it clear where a shadow DOM exists. For example, the preceding example will appear as the following in the browser inspector:

```
<body>  
<div>  
  #shadow-root (open)  
    <p>Make me red!</p>
```

```

    <style>
    p {
      color: red;
    }
    </style>
  </div>
  <div>
    #shadow-root (open)
    <p>Make me green!</p>

    <style>
    p {
      color: green;
    }
    </style>
  </div>
  <div>
    #shadow-root (open)
    <p>Make me blue!</p>

    <style>
    p {
      color: blue;
    }
    </style>
  </div>
</body>

```

Shadow DOMs are not an impermeable boundary. An HTML element can be moved between DOM trees without restriction:

```

document.body.innerHTML = `
<div></div>
<p id="foo">Move me</p>
`;

const divElement = document.querySelector('div');
const pElement = document.querySelector('p');

const shadowDOM = divElement.attachShadow({ mode: 'open' });

// Remove element from parent DOM
divElement.parentElement.removeChild(pElement);

// Add element to shadow DOM
shadowDOM.appendChild(pElement);

// Check to see that element was moved
console.log(shadowDOM.innerHTML); // <p id="foo">Move me</p>

```

Composition and Shadow DOM Slots

The shadow DOM is designed to enable customizable components, and this requires the ability to handle nested DOM fragments. Conceptually, this is relatively straightforward: HTML inside a shadow host element needs a way to render inside the shadow DOM without actually being part of the shadow DOM tree.

By default, nested content will be hidden. Consider the following example where the text becomes hidden after 1000 milliseconds:

```
document.body.innerHTML = `
<div>
  <p>Foo</p>
</div>
`;

setTimeout(() => document.querySelector('div').attachShadow({ mode: 'open' }), 1000);
```

Once the shadow DOM is attached, the browser gives priority to the shadow DOM and will render its contents instead of the text. In this example, the shadow DOM is empty, so the `<div>` will appear empty in turn.

To show this content, you can use a `<slot>` tag to instruct where the browser should place the HTML. In the code that follows, the previous example is reworked so the text reappears inside the shadow DOM:

```
document.body.innerHTML = `
<div id="foo">
  <p>Foo</p>
</div>
`;

document.querySelector('div')
  .attachShadow({ mode: 'open' })
  .innerHTML = `<div id="bar">
    <slot></slot>
  </div>`
```

Now, the projected content will behave as if it exists inside the shadow DOM. Inspecting the page reveals that the content appears to actually replace the `<slot>`:

```
<body>
<div id="foo">
  #shadow-root (open)
    <div id="bar">
      <p>Foo</p>
    </div>
</div>
</body>
```

Note that, despite its appearance in the page inspector, this is only a *projection* of DOM content. The element remains attached to the outer DOM:

```
document.body.innerHTML = `
<div id="foo">
  <p>Foo</p>
</div>
`;

document.querySelector('div')
  .attachShadow({ mode: 'open' })
  .innerHTML = `
```

```

    <div id="bar">
      <slot></slot>
    </div>`

console.log(document.querySelector('p').parentElement);
// <div id="foo"></div>

```

The red-green-blue example from before can be reworked to use slots as follows:

```

for (let color of ['red', 'green', 'blue']) {
  const divElement = document.createElement('div');
  divElement.innerText = `Make me ${color}`;
  document.body.appendChild(divElement)

  divElement
    .attachShadow({ mode: 'open' })
    .innerHTML = `
    <p><slot></slot></p>

    <style>
      p {
        color: ${color};
      }
    </style>
    `;
}

```

It's also possible to use *named slots* to perform multiple projections. This is accomplished with matching `slot/name` attribute pairs. The element identified with a `slot="foo"` attribute will be projected into the `<slot>` with `name="foo"`. The following example demonstrates this by switching the rendered order of the shadow host element's children:

```

document.body.innerHTML = `
<div>
  <p slot="foo">Foo</p>
  <p slot="bar">Bar</p>
</div>
`;

document.querySelector('div')
  .attachShadow({ mode: 'open' })
  .innerHTML = `
  <slot name="bar"></slot>
  <slot name="foo"></slot>
  `;

// Renders:
// Bar
// Foo

```

Event Retargeting

If a browser event like `click` occurs inside a shadow DOM, the browser needs a way for the parent DOM to handle the event. However, the implementation must also respect the shadow DOM boundary. To address this, events that escape a shadow DOM and are handled outside undergo

event retargeting. Once escaped, this event will appear to have been thrown by the shadow host itself instead of the true encapsulated element. This behavior is demonstrated here:

```
// Create element to be shadow host
document.body.innerHTML = `
<div onclick="console.log('Handled outside:', event.target)"></div>
`;

// Attach shadow DOM and insert HTML into it
document.querySelector('div')
  .attachShadow({ mode: 'open' })
  .innerHTML = `
<button onclick="console.log('Handled inside:', event.target)">Foo</button>
`;

// When clicking the button:
// Handled inside: <button onclick="..."></button>
// Handled outside: <div onclick="..."></div>
```

Note that retargeting only occurs for elements that actually exist inside a shadow DOM. Elements projected from outside using a `<slot>` tag will not have their events retargeted, as they still technically exist outside the shadow DOM.

Custom Elements

If you've used a JavaScript framework, you're likely familiar with the concept of custom elements, as all major frameworks provide this feature in some form. Custom elements introduce an object-oriented programming flavor to HTML elements. With them, it is possible to create custom, complex, and reusable elements and create instances with a simple HTML tag or attribute.

Defining a Custom Element

Browsers already will attempt to incorporate unrecognized elements into the DOM as generic elements. Of course, by default they won't do anything special that a generic HTML element doesn't already do. Consider the following example, where a nonsense HTML tag becomes an instance of an `HTMLElement`:

```
document.body.innerHTML = `
<x-foo >I'm inside a nonsense element.</x-foo >
`;

console.log(document.querySelector('x-foo') instanceof HTMLElement); // true
```

Custom elements take this further. They allow you to define complex behavior whenever an `<x-foo>` tag appears, and also to tap into the element's lifecycle with respect to the DOM. Custom element definition is accomplished using the global `customElements` property, which returns the `CustomElementRegistry` object.

```
console.log(customElements); // CustomElementRegistry {}
```

Defining a custom element is accomplished with the `define()` method. The following creates a trivial custom element, which inherits from a vanilla `HTMLElement`:

```
class FooElement extends HTMLElement {}
customElements.define('x-foo', FooElement);

document.body.innerHTML = `
<x-foo >I'm inside a nonsense element.</x-foo >
`;

console.log(document.querySelector('x-foo') instanceof FooElement); // true
```

NOTE Custom element names must have at least one hyphen that does not start or end the name string, and the element tag must not self-close.

The power of custom elements is housed in the class definition. For example, now each instance of this class in the DOM will call the constructor that you control:

```
class FooElement extends HTMLElement {
  constructor() {
    super();
    console.log('x-foo')
  }
}
customElements.define('x-foo', FooElement);

document.body.innerHTML = `
<x-foo></x-foo>
<x-foo></x-foo>
<x-foo></x-foo>
`;

// x-foo
// x-foo
// x-foo
```

NOTE `super()` must always be called first in the custom element constructor. If the element inherits from `HTMLElement` or similar without overriding the constructor, calling `super()` is not necessary as the prototype constructor will do it by default. It is very rare to define a custom element that should not inherit from `HTMLElement`.

If a custom element inherits from an element class, the tag can be specified as an instance of that custom element using the `is` attribute and the `extends` option:

```
class FooElement extends HTMLDivElement {
  constructor() {
```

```

        super();
        console.log('x-foo')
    }
}
customElements.define('x-foo', FooElement, { extends: 'div' });

document.body.innerHTML = `
<div is="x-foo"></div>
<div is="x-foo"></div>
<div is="x-foo"></div>
`;

// x-foo
// x-foo
// x-foo

```

Adding Web Component Content

Because the custom element class constructor is called each time the element is added to the DOM, it is easy to automatically populate a custom element with child DOM content. Although you are forbidden from adding DOM children inside the constructor (a `DOMException` will be thrown), you can attach a shadow DOM and place content inside:

```

class FooElement extends HTMLElement {
  constructor() {
    super();

    // 'this' refers to the web component node
    this.attachShadow({ mode: 'open' });

    this.shadowRoot.innerHTML = `
      <p>I'm inside a custom element!</p>
    `;
  }
}
customElements.define('x-foo', FooElement);

document.body.innerHTML += `<x-foo></x-foo`;

// Resulting DOM:
// <body>
// <x-foo>
//   #shadow-root (open)
//     <p>I'm inside a custom element!</p>
// <x-foo>
// </body>

```

To avoid the nastiness of string templates and `innerHTML`, this example can be refactored to use HTML templates and `document.createElement()`:

```

// (Initial HTML)
// <template id="x-foo-tpl">
//   <p>I'm inside a custom element template!</p>
// </template>

```

```

const template = document.querySelector('#x-foo-tpl');

class FooElement extends HTMLElement {
  constructor() {
    super();

    this.attachShadow({ mode: 'open' });

    this.shadowRoot.appendChild(template.content.cloneNode(true));
  }
}
customElements.define('x-foo', FooElement);

document.body.innerHTML += `<x-foo></x-foo`;

// Resulting DOM:
// <body>
// <template id="x-foo-tpl">
//   <p>I'm inside a custom element template!</p>
// </template>
// <x-foo>
//   #shadow-root (open)
//     <p>I'm inside a custom element template!</p>
// </x-foo>
// </body>

```

This practice allows for a high degree of HTML and code reuse as well as DOM encapsulation inside your custom element. With it, you are free to build reusable widgets without fear of outside CSS trampling your styling.

Using Custom Element Lifecycle Hooks

It is possible to execute code at various points in the lifecycle of a custom element. Instance methods on the custom element class with the corresponding name will be called during that lifecycle phase. There are five available hooks:

- `constructor()` is called when an element instance is created, or an existing DOM element is upgraded to a custom element.
- `connectedCallback()` is called each time this instance of the custom element is added into the DOM.
- `disconnectedCallback()` is called each time this instance of the custom element is removed from the DOM.
- `attributeChangedCallback()` is called each time the value of an *observed attribute* is changed. When the element instance is instantiated, definition of the initial value counts as a change.
- `adoptedCallback()` is called each time this instance is moved to a new document object with `document.adoptNode()`.

The following example demonstrates the construction, connected, and disconnected callbacks:

```
class FooElement extends HTMLElement {
  constructor() {
    super();
    console.log('ctor');
  }

  connectedCallback() {
    console.log('connected');
  }

  disconnectedCallback() {
    console.log('disconnected');
  }
}
customElements.define('x-foo', FooElement);

const fooElement = document.createElement('x-foo');
// ctor

document.body.appendChild(fooElement);
// connected

document.body.removeChild(fooElement);
// disconnected
```

Reflecting Custom Element Attributes

Because an element exists as both a DOM entity and a JavaScript object, a common pattern is to reflect changes between the two. In other words, a change to the DOM should reflect a change in the object, and vice versa. To reflect from the object to the DOM, a common strategy is to use getters and setters. The following example reflects the `bar` property of the object up to the DOM:

```
document.body.innerHTML = `
```

```
console.log(document.body.innerHTML);
// <x-foo bar="true"></x-foo>
```

Reflecting in the reverse direction—from the DOM to the object—requires setting a listener for that attribute. To accomplish this, you can instruct the custom element to call the `attributeChangedCallback()` each time the attribute’s value changes by using the `observedAttributes()` getter:

```
class FooElement extends HTMLElement {
  static get observedAttributes() {
    // List attributes which should trigger attributeChangedCallback()
    return ['bar'];
  }

  get bar() {
    return this.getAttribute('bar');
  }

  set bar(value) {
    this.setAttribute('bar', value)
  }

  attributeChangedCallback(name, oldValue, newValue) {
    if (oldValue !== newValue) {
      console.log(`${oldValue} -> ${newValue}`);

      this[name] = newValue;
    }
  }
}

customElements.define('x-foo', FooElement);

document.body.innerHTML = `<x-foo bar="false"></x-foo>`;
// null -> false

document.querySelector('x-foo').setAttribute('bar', true);
// false -> true
```

Upgrading Custom Elements

It’s not always possible to define a custom element before the custom element tag appears in the DOM. Web components address this ordering problem by exposing several additional methods on the `CustomElementRegistry` that allow you to detect when a custom element is eventually defined and upgrade existing elements.

The `CustomElementRegistry.get()` method returns the custom element class if it was already defined. In a similar vein, the `CustomElementRegistry.whenDefined()` method returns a promise that resolves when a custom element becomes defined:

```
customElements.whenDefined('x-foo').then(() => console.log('defined!'));

console.log(customElements.get('x-foo'));
// undefined
```

```

customElements.define('x-foo', class {});
// defined!

console.log(customElements.get('x-foo'));
// class FooElement {}

```

Elements connected to the DOM will be *automatically* upgraded when the custom element is defined. If you wish to forcibly upgrade an element before it is connected to the DOM, this can be accomplished with `CustomElementRegistry.upgrade()`:

```

// Create HTMLUnknownElement object before custom element definition
const fooElement = document.createElement('x-foo');

// Define custom element
class FooElement extends HTMLElement {}
customElements.define('x-foo', FooElement);

console.log(fooElement instanceof FooElement); // false

// Force the upgrade
customElements.upgrade(fooElement);

console.log(fooElement instanceof FooElement); // true

```

NOTE *There is also an HTML imports web component, but the specification remains a working draft and no major browsers support it. It remains unclear if any browsers will eventually add support.*

THE WEB CRYPTOGRAPHY API

The Web Cryptography API (<https://www.w3.org/TR/WebCryptoAPI>) describes a suite of cryptography tools that standardize how JavaScript can wield cryptographic behavior in a secure and idiomatic fashion. These tools include the ability to generate, use, and apply cryptographic key pairs; encrypt and decrypt messages; and robustly generate random numbers.

NOTE *The organization of the cryptography is somewhat bizarre, featuring an outer `Crypto` object with an inner `SubtleCrypto` object. Before the Web Cryptography API was standardized, the `window.crypto` property was highly fragmented across browsers. To allow for cross-browser compatibility, the bulk of the API is exposed on the `SubtleCrypto` object.*

Random Number Generation

When tasked with generating random values, most developers reach for `Math.random()`. This method is implemented in browsers as a *pseudorandom number generator* (PRNG). The "pseudo" designation stems from the nature of the value generation in that it is not truly random. Values

emitted from a PRNG only *emulate* properties that are associated with randomness. This appearance of randomness is made possible through some clever engineering. The browser's PRNG doesn't utilize any true sources of randomness—it is purely a fixed algorithm applied to a hermetic internal state. Each time `Math.random()` is called, the internal state is mutated by an algorithm and the result is converted into a new random value. For example, the V8 engine uses an algorithm called `xorshift128+` to perform this mutation.

Because this algorithm is fixed and its input is *only* the previous state, the order of random numbers is deterministic. `xorshift128+` uses 128 bits of internal state, and the algorithm is designed such that any initial state will produce a sequence of $2^{128}-1$ pseudorandom values before repeating itself. This looping behavior is called a *permutation cycle*, and the length of this cycle is referred to as the *period*. The implications of this are clear: If an attacker knows the internal state of the PRNG, they are able to predict the pseudorandom values that it will subsequently emit. If an unwitting developer were to use the PRNG to generate a private key for the purposes of encryption, the attacker could use the properties of the PRNG to determine the private key.

Pseudorandom number generators are designed to be able to quickly calculate values that seem to be random. They are, however, unsuitable for the purposes of cryptographic computation. To address this, a *cryptographically secure pseudorandom number generator* (CSPRNG) additionally incorporates a source of entropy as its input, such as measuring hardware timings or other system properties that exhibit unpredictable behavior. Doing so is much slower than a regular PRNG, but values emitted by a CSPRNG are sufficiently unpredictable for cryptographic purposes.

The Web Cryptography API introduces a CSPRNG that can be accessed on the global `crypto` object via `crypto.getRandomValues()`. Unlike `Math.random()`, which returns a floating point number between 0 and 1, `getRandomValues()` writes random numbers into the typed array provided as a parameter. The typed array class is not important, as the underlying buffer is being filled with random binary bits.

The following generates five 8-bit random values:

```
const array = new Uint8Array(1);

for (let i=0; i<5; ++i) {
  console.log(crypto.getRandomValues(array));
}

// Uint8Array [41]
// Uint8Array [250]
// Uint8Array [51]
// Uint8Array [129]
// Uint8Array [35]
```

`getRandomValues()` will generate up to 2^{16} bytes; above that it will throw an error:

```
const fooArray = new Uint8Array(2 ** 16);
console.log(window.crypto.getRandomValues(fooArray)); // Uint32Array(16384) [...]

const barArray = new Uint8Array((2 ** 16) + 1);
console.log(window.crypto.getRandomValues(barArray)); // Error
```

Reimplementing `Math.random()` using the CSPRNG could be accomplished by generating a single random 32-bit number and dividing this into the maximum possible value, `0xFFFFFFFF`. This yields a value between 0 and 1:

```
function randomFloat() {
  // Generate 32 random bits
  const fooArray = new Uint32Array(1);

  // Maximum value is 2^32 - 1
  const maxUint32 = 0xFFFFFFFF;

  // Divide by maximum possible value
  return crypto.getRandomValues(fooArray)[0] / maxUint32;
}

console.log(randomFloat()); // 0.5033651619458955
```

Using the SubtleCrypto Object

The overwhelming majority of the Web Cryptography API resides inside the `SubtleCrypto` object, accessible via `window.crypto.subtle`:

```
console.log(crypto.subtle); // SubtleCrypto {}
```

This object contains a collection of methods for performing common cryptographic functions such as encryption, hashing, signing, and key generation. Because all cryptographic operations are performed on raw binary data, every `SubtleCrypto` method deals in `ArrayBuffer` and `ArrayBufferView` types. Because strings are so frequently the subject of cryptographic operations, the `TextEncoder` and `TextDecoder` classes will often be used alongside `SubtleCrypto` to convert to and from strings.

NOTE *The `SubtleCrypto` object is only accessible in a secure context (`https`). In an insecure context, the `subtle` property will be undefined.*

Generating Cryptographic Digests

One extremely common cryptography operation is to calculate a cryptographic digest of data. The specification supports four algorithms for this, *SHA-1* and three flavors of *SHA-2*:

- ▶ **Secure Hash Algorithm 1 (SHA-1)**—A hash function with an architecture similar to MD5. It takes an input of any size and generates a 160-bit message digest. This algorithm is no longer considered secure as it is vulnerable to collision attacks.
- ▶ **Secure Hash Algorithm 2 (SHA-2)**—A family of hash functions all built upon the same collision-resistant one-way compression function. The specification supports three members of this family: *SHA-256*, *SHA-384*, and *SHA-512*. The size of the generated message digest can be 256 bits (*SHA-256*), 384 bits (*SHA-384*), or 512 bits (*SHA-512*). This algorithm is considered secure and widely used in many applications and protocols, including TLS, PGP, and cryptocurrencies like Bitcoin.

The `SubtleCrypto.digest()` method is used to generate a message digest. The hash algorithm is specified using a string: SHA-1, SHA-256, SHA-384, or SHA-512. The following example demonstrates a simple application of SHA-256 to generate a message digest of the string `foo`:

```
(async function() {
  const textEncoder = new TextEncoder();
  const message = textEncoder.encode('foo');
  const messageDigest = await crypto.subtle.digest('SHA-256', message);

  console.log(new Uint32Array(messageDigest));
})();

// Uint32Array(8) [1806968364, 2412183400, 1011194873, 876687389,
//                 1882014227, 2696905572, 2287897337, 2934400610]
```

Commonly, the message digest binary will be used in a hex string format. Converting an array buffer to this format is accomplished by splitting the buffer up into 8-bit pieces and converting using `toString()` in base 16:

```
(async function() {
  const textEncoder = new TextEncoder();
  const message = textEncoder.encode('foo');
  const messageDigest = await crypto.subtle.digest('SHA-256', message);

  const hexDigest = Array.from(new Uint8Array(messageDigest))
    .map((x) => x.toString(16).padStart(2, '0'))
    .join('');

  console.log(hexDigest);
})();

// 2c26b46b68ffc68ff99b453cd1d30413413422d706483bfa0f98a5e886266e7ae
```

Software companies usually publish a digest of their install binaries so that people who wish to safely install their software can verify that the binary they download is the version that the company actually published (and not one with injected malware). The following example downloads v67.0 of Firefox, hashes it with SHA-512, downloads the SHA-512 binary verification, and checks that the two hex strings match:

```
(async function() {
  const mozillaCdnUrl = '//download-
origin.cdn.mozilla.net/pub/firefox/releases/67.0/';
  const firefoxBinaryFilename = 'linux-x86_64/en-US/firefox-67.0.tar.bz2';
  const firefoxShaFilename = 'SHA512SUMS';

  console.log('Fetching Firefox binary...');
  const fileArrayBuffer = await (await fetch(mozillaCdnUrl + firefoxBinaryFilename))
    .arrayBuffer();

  console.log('Calculating Firefox digest...');
  const firefoxBinaryDigest = await crypto.subtle.digest('SHA-512', fileArrayBuffer);
```

```
const firefoxHexDigest = Array.from(new Uint8Array(firefoxBinaryDigest))
  .map((x) => x.toString(16).padStart(2, '0'))
  .join('');

console.log('Fetching published binary digests...');
// The SHA file contains digests of every firefox binary in this release,
// so there is some organization performed.
const shaPairs = (await (await fetch(mozillaCdnUrl + firefoxShaFilename)).text())
  .split(/\n/).map((x) => x.split(/\s+/));

let verified = false;

console.log('Checking calculated digest against published digests...');
for (const [sha, filename] of shaPairs) {
  if (filename === firefoxBinaryFilename) {
    if (sha === firefoxHexDigest) {
      verified = true;
      break;
    }
  }
}

console.log('Verified:', verified);
})();

// Fetching Firefox binary...
// Calculating Firefox digest...
// Fetching published binary digests...
// Checking calculated digest against published digests...
// Verified: true
```

CryptoKeys and Algorithms

Cryptography would be meaningless without secret keys, and the `SubtleCrypto` object uses instances of the `CryptoKey` class to house these secrets. The `CryptoKey` class supports multiple types of encryption algorithms and allows for control over key extraction and usage.

The `CryptoKey` class supports the following algorithms, categorized by their parent cryptosystem:

- **RSA (Rivest-Shamir-Adleman)**—A public-key cryptosystem in which two large prime numbers are used to derive a pair of public and private keys that can be used to sign/verify or encrypt/decrypt messages. The trapdoor function for RSA is called the *factoring problem*.
- **RSASSA-PKCS1-v1_5**—An application of RSA used to sign messages with the private key and allow that signature to be verified with the public key.
 - *SSA* stands for *signature schemes with appendix*, indicating the algorithm supports signature generation and verification operations.
 - *PKCS1* stands for *Public-Key Cryptography Standards #1*, indicating the algorithm exhibits mathematical properties that RSA keys must have.
 - **RSASSA-PKCS1-v1_5** is deterministic, meaning the same message and key will produce an identical signature each time it is performed.

- **RSA-PSS**—Another application of RSA used to sign and verify messages.
 - PSS stands for *probabilistic signature scheme*, indicating that the signature generation incorporates a salt to randomize the signature.
 - Unlike RSASSA-PKCS1-v1_5, the same message and key will produce a different signature each time it is performed.
 - Unlike RSASSA-PKCS1-v1_5, RSA-PSS is provably reducible to the hardness of the RSA factoring problem.
 - In general, although RSASSA-PKCS1-v1_5 is still considered secure, RSA-PSS should be used as a replacement for RSASSA-PKCS1-v1_5.
- **RSA-OAEP**—An application of RSA used to encrypt messages with the public key and decrypt them with the private key.
 - OAEP stands for *Optimal Asymmetric Encryption Padding*, indicating that the algorithm utilizes a Feistel network to process the unencrypted message prior to encryption.
 - OAEP serves to convert the deterministic RSA encryption scheme to a probabilistic encryption scheme.
- **ECC (Elliptic-Curve Cryptography)**—A public-key cryptosystem in which a prime number and an elliptic curve are used to derive a pair of public and private keys that can be used to sign/verify messages. The trapdoor function for ECC is called the *elliptic curve discrete logarithm problem*. ECC is considered to be superior to RSA: Although both RSA and ECC are cryptographically strong, ECC keys are shorter than RSA keys and ECC cryptographic operations are faster than RSA operations.
- **ECDSA (Elliptic Curve Digital Signature Algorithm)**—An application of ECC used to sign and verify messages. This algorithm is an elliptic curve–flavored variant of the *Digital Signature Algorithm (DSA)*.
- **ECDH (Elliptic Curve Diffie-Hellman)**—A key-generation and key-agreement application of ECC that allows for two parties to establish a shared secret over a public communication channel. This algorithm is an elliptic curve-flavored variant of the *Diffie-Hellman key exchange (DH)* protocol.
- **AES (Advanced Encryption Standard)**—A symmetric-key cryptosystem that encrypts/decrypts data using a block cipher derived from a substitution-permutation network. AES is used in different *modes*, which change the algorithm’s characteristics.
- **AES-CTR**—The *counter mode* of AES. This mode behaves as a stream cipher by using an incremented counter to generate its keystream. It must also be provided a nonce, which is effectively used as an initialization vector. AES-CTR encryption/decryption is able to be parallelized.
- **AES-CBC**—The *cipher block chaining mode* of AES. Before encrypting each block of plaintext, it is XORed with the previous block of ciphertext—hence the "chaining" name. An initialization vector is used as the XOR input for the first block.

- **AES-GCM**—The *Galois/Counter mode* of AES. This mode uses a counter and initialization vector to generate a value, which is XORed with the plaintext of each block. Unlike CBC, the XOR inputs do not have dependencies on the previous block's encryption and therefore the GCM mode can be parallelized. Because of its excellent performance characteristics, AES-GCM enjoys utilization in many networking security protocols.
- **AES-KW**—The *key wrapping mode* of AES. This algorithm wraps a secret key into a portable and encrypted format that is safe for transmission on an untrusted channel. Once transmitted, the receiving party can then unwrap the key. Unlike other AES modes, AES-KW does not require an initialization vector.
- **HMAC (Hash-Based Message Authentication Code)**—An algorithm that generates *message authentication codes* used to verify that a message arrives unaltered when sent over an untrusted network. Two parties use a hash function and a shared private key to sign and verify messages.
- **KDF (Key Derivation Functions)**—Algorithms that can derive one or many keys from a master key using a hash function. KDFs are capable of generating keys of a different length or converting keys to different formats.
- **HKDF (HMAC-Based Key Derivation Function)**—A key derivation function designed to be used with a high-entropy input such as an existing key.
- **PBKDF2 (Password-Based Key Derivation Function 2)**—A key derivation function designed to be used with a low-entropy input such as a password string.

NOTE *The CryptoKey supports a large number of algorithms, but only some algorithms are applicable to some SubtleCrypto methods. Refer to the specification for an overview of which algorithms are supported for which methods:*
<https://www.w3.org/TR/WebCryptoAPI/#algorithm-overview>.

Generating CryptoKeys

Generating a random `CryptoKey` is accomplished with the `SubtleCrypto.generateKey()` method, which returns a promise that resolves to one or many `CryptoKey` instances. This method is passed a `params` object specifying the target algorithm, a boolean indicating whether or not the key should be extractable from the `CryptoKey` object, and an array of strings—`keyUsages`—indicating which `SubtleCrypto` methods the key can be used with.

Because different cryptosystems require different inputs to generate keys, the `params` object provides the required inputs for each cryptosystem:

- The RSA cryptosystem uses an `RsaHashedKeyGenParams` object.
- The ECC cryptosystem uses an `EcKeyGenParams` object.
- The HMAC cryptosystem uses an `HmacKeyGenParams` object.
- The AES cryptosystem uses an `AesKeyGenParams` object.

The `keyUsages` object describes which algorithms the key can be used with. It expects at least one of the following strings:

- `encrypt`
- `decrypt`
- `sign`
- `verify`
- `deriveKey`
- `deriveBits`
- `wrapKey`
- `unwrapKey`

Suppose you want to generate a symmetric key with the following properties:

- Supports the AES-CTR algorithm
- Key length of 128 bits
- Cannot be extracted from the `CryptoKey` object
- Is able to be used with the `encrypt()` and `decrypt()` methods

Generating this key can be accomplished in the following fashion:

```
(async function() {
  const params = {
    name: 'AES-CTR',
    length: 128
  };

  const keyUsages = ['encrypt', 'decrypt'];

  const key = await crypto.subtle.generateKey(params, false, keyUsages);

  console.log(key);
  // CryptoKey {type: "secret", extractable: true, algorithm: {...}, usages: Array(2)}
})();
```

Suppose you want to generate an asymmetric key pair with the following properties:

- Supports the ECDSA algorithm
- Uses the P-256 elliptic curve
- Can be extracted from the `CryptoKey` object
- Is able to be used with the `sign()` and `verify()` methods

Generating this key pair can be accomplished in the following fashion:

```
(async function() {
  const params = {
    name: 'ECDSA',
    namedCurve: 'P-256'
  };

  const keyUsages = ['sign', 'verify'];

  const {publicKey, privateKey} = await crypto.subtle.generateKey(params, true,
    keyUsages);

  console.log(publicKey);
  // CryptoKey {type: "public", extractable: true, algorithm: {...}, usages: Array(1)}

  console.log(privateKey);
  // CryptoKey {type: "private", extractable: true, algorithm: {...}, usages: Array(1)}
})();
```

Exporting and Importing Keys

If a key is extractable, it is possible to expose the raw key binary from inside the `CryptoKey` object. The `exportKey()` method allows you to do so while also specifying the target format (`raw`, `pkcs8`, `spki`, or `jwk`). The method returns a promise that resolves to an `ArrayBuffer` containing the key:

```
(async function() {
  const params = {
    name: 'AES-CTR',
    length: 128
  };
  const keyUsages = ['encrypt', 'decrypt'];

  const key = await crypto.subtle.generateKey(params, true, keyUsages);

  const rawKey = await crypto.subtle.exportKey('raw', key);

  console.log(new Uint8Array(rawKey));
  // Uint8Array[93, 122, 66, 135, 144, 182, 119, 196, 234, 73, 84, 7, 139, 43, 238,
  // 110]
})();
```

The inverse operation of `exportKey()` is `importKey()`. This method's signature is essentially a combination of `generateKey()` and `exportKey()`. The following method generates a key, exports it, and imports it once again:

```
(async function() {
  const params = {
    name: 'AES-CTR',
    length: 128
  };
  const keyUsages = ['encrypt', 'decrypt'];
  const keyFormat = 'raw';
  const isExtractable = true;
```

```

const key = await crypto.subtle.generateKey(params, isExtractable, keyUsages);

const rawKey = await crypto.subtle.exportKey(keyFormat, key);

const importedKey = await crypto.subtle.importKey(keyFormat, rawKey, params.name,
  isExtractable, keyUsages);

console.log(importedKey);
// CryptoKey {type: "secret", extractable: true, algorithm: {...}, usages: Array(2)}
}();

```

Deriving Keys from Master Keys

The `SubtleCrypto` object allows you to derive new keys with configurable properties from an existing secret. It supports a `deriveKey()` method that returns a promise resolving to a `CryptoKey`, and a `deriveBits()` method that returns a promise resolving to an `ArrayBuffer`.

NOTE *The difference between `deriveKey()` and `deriveBits()` is trivial, as calling `deriveKey()` is effectively the same as calling `deriveBits()` and passing the result to `importKey()`.*

The `deriveBits()` function accepts an algorithm params object, the master key, and the length in bits of the output. This can be used in situations where two people, each with their own key pairs, wish to obtain a shared secret key. The following example uses the ECDH algorithm to generate reciprocal keys from two keypairs and ensures that they derive the same key bits:

```

(async function() {
  const ellipticCurve = 'P-256';
  const algoIdentifier = 'ECDH';
  const derivedKeySize = 128;

  const params = {
    name: algoIdentifier,
    namedCurve: ellipticCurve
  };

  const keyUsages = ['deriveBits'];

  const keyPairA = await crypto.subtle.generateKey(params, true, keyUsages);
  const keyPairB = await crypto.subtle.generateKey(params, true, keyUsages);

  // Derive key bits from A's public key and B's private key
  const derivedBitsAB = await crypto.subtle.deriveBits(
    Object.assign({ public: keyPairA.publicKey }, params),
    keyPairB.privateKey,
    derivedKeySize);

  // Derive key bits from B's public key and A's private key
  const derivedBitsBA = await crypto.subtle.deriveBits(

```



```
    Object.assign({ public: keyPairB.publicKey }, params),
    keyPairA.privateKey,
    derivedKeySize);

const arrayAB = new Uint32Array(derivedBitsAB);
const arrayBA = new Uint32Array(derivedBitsBA);

// Ensure key arrays are identical
console.log(
  arrayAB.length === arrayBA.length &&
  arrayAB.every((val, i) => val === arrayBA[i])); // true
})();
```

The `deriveKey()` method behaves similarly, returning an instance of a `CryptoKey` instead of an `ArrayBuffer`. The following example takes a raw string, applies the PBKDF2 algorithm to import it into a raw master key, and derives a new key in AES-GCM format:

```
(async function() {
  const password = 'foobar';
  const salt = crypto.getRandomValues(new Uint8Array(16));
  const algoIdentifier = 'PBKDF2';
  const keyFormat = 'raw';
  const isExtractable = false;

  const params = {
    name: algoIdentifier
  };

  const masterKey = await window.crypto.subtle.importKey(
    keyFormat,
    (new TextEncoder()).encode(password),
    params,
    isExtractable,
    ['deriveKey']
  );

  const deriveParams = {
    name: 'AES-GCM',
    length: 128
  };

  const derivedKey = await window.crypto.subtle.deriveKey(
    Object.assign({salt, iterations: 1E5, hash: 'SHA-256'}, params),
    masterKey,
    deriveParams,
    isExtractable,
    ['encrypt']
  );

  console.log(derivedKey);
  // CryptoKey {type: "secret", extractable: false, algorithm: {...}, usages: Array(1)}
})();
```

Signing and Verifying Messages with Asymmetric Keys

The `SubtleCrypto` object allows you to use public-key algorithms to generate signatures using a private key or to verify signatures using a public key. These are performed using the `SubtleCrypto.sign()` and `SubtleCrypto.verify()` methods, respectively.

Signing a message requires a `params` object to specify the algorithm and any necessary values, the private `CryptoKey`, and the `ArrayBuffer` or `ArrayBufferView` to be signed. The following example generates an elliptic curve key pair and uses the private key to sign a message:

```
(async function() {
  const keyParams = {
    name: 'ECDSA',
    namedCurve: 'P-256'
  };

  const keyUsages = ['sign', 'verify'];

  const {publicKey, privateKey} = await crypto.subtle.generateKey(keyParams, true,
    keyUsages);

  const message = (new TextEncoder()).encode('I am Satoshi Nakamoto');

  const signParams = {
    name: 'ECDSA',
    hash: 'SHA-256'
  };

  const signature = await crypto.subtle.sign(signParams, privateKey, message);

  console.log(new Uint32Array(signature));
  // Uint32Array(16) [2202267297, 698413658, 1501924384, 691450316, 778757775, ... ]
})();
```

An individual wishing to verify this message against the signature could use the public key and the `SubtleCrypto.verify()` method. This method's signature is nearly identical to `sign()` with the exception that it must be provided the public key as well as the signature. The following example extends the previous example by verifying the generated signature:

```
(async function() {
  const keyParams = {
    name: 'ECDSA',
    namedCurve: 'P-256'
  };

  const keyUsages = ['sign', 'verify'];

  const {publicKey, privateKey} = await crypto.subtle.generateKey(keyParams, true,
    keyUsages);

  const message = (new TextEncoder()).encode('I am Satoshi Nakamoto');

  const signParams = {
```

```
    name: 'ECDSA',
    hash: 'SHA-256'
  };

  const signature = await crypto.subtle.sign(signParams, privateKey, message);

  const verified = await crypto.subtle.verify(signParams, publicKey, signature,
    message);

  console.log(verified); // true
}());
```

Encrypting and Decrypting with Symmetric Keys

The `SubtleCrypto` object allows you to use both public-key and symmetric algorithms to encrypt and decrypt messages. These are performed using the `SubtleCrypto.encrypt()` and `SubtleCrypto.decrypt()` methods, respectively.

Encrypting a message requires a `params` object to specify the algorithm and any necessary values, the encryption key, and the data to be encrypted. The following example generates a symmetric AES-CBC key, encrypts it, and finally decrypts a message:

```
(async function() {
  const algoIdentifier = 'AES-CBC';

  const keyParams = {
    name: algoIdentifier,
    length: 256
  };

  const keyUsages = ['encrypt', 'decrypt'];

  const key = await crypto.subtle.generateKey(keyParams, true,
    keyUsages);

  const originalPlaintext = (new TextEncoder()).encode('I am Satoshi Nakamoto');

  const encryptDecryptParams = {
    name: algoIdentifier,
    iv: crypto.getRandomValues(new Uint8Array(16))
  };

  const ciphertext = await crypto.subtle.encrypt(encryptDecryptParams, key,
    originalPlaintext);

  console.log(ciphertext);
  // ArrayBuffer(32) {}

  const decryptedPlaintext = await crypto.subtle.decrypt(encryptDecryptParams, key,
    ciphertext);

  console.log((new TextDecoder()).decode(decryptedPlaintext));
  // I am Satoshi Nakamoto
})();
```

Wrapping and Unwrapping a Key

The `SubtleCrypto` object allows you to wrap and unwrap keys to allow for transmission over an untrusted channel. These are performed using the `SubtleCrypto.wrapKey()` and `SubtleCrypto.unwrapKey()` methods, respectively.

Wrapping a key requires a format string, the `CryptoKey` instance to be wrapped, the `CryptoKey` to perform the wrapping, and a `params` object to specify the algorithm and any necessary values. The following example generates a symmetric AES-GCM key, wraps the key with AES-KW, and finally unwraps the key:

```
(async function() {
  const keyFormat = 'raw';
  const extractable = true;

  const wrappingKeyAlgoIdentifier = 'AES-KW';
  const wrappingKeyUsages = ['wrapKey', 'unwrapKey'];
  const wrappingKeyParams = {
    name: wrappingKeyAlgoIdentifier,
    length: 256
  };

  const keyAlgoIdentifier = 'AES-GCM';
  const keyUsages = ['encrypt'];
  const keyParams = {
    name: keyAlgoIdentifier,
    length: 256
  };

  const wrappingKey = await crypto.subtle.generateKey(wrappingKeyParams, extractable,
    wrappingKeyUsages);

  console.log(wrappingKey);
  // CryptoKey {type: "secret", extractable: true, algorithm: {...}, usages: Array(2)}

  const key = await crypto.subtle.generateKey(keyParams, extractable, keyUsages);

  console.log(key);
  // CryptoKey {type: "secret", extractable: true, algorithm: {...}, usages: Array(1)}

  const wrappedKey = await crypto.subtle.wrapKey(keyFormat, key, wrappingKey,
    wrappingKeyAlgoIdentifier);

  console.log(wrappedKey);
  // ArrayBuffer(40) {}

  const unwrappedKey = await crypto.subtle.unwrapKey(keyFormat, wrappedKey,
    wrappingKey, wrappingKeyParams, keyParams, extractable, keyUsages);

  console.log(unwrappedKey);
  // CryptoKey {type: "secret", extractable: true, algorithm: {...}, usages: Array(1)}
})();
```

SUMMARY

HTML5, in addition to defining new markup rules, also defines several JavaScript APIs. These APIs are designed to enable better web interfaces that can rival the capabilities of desktop applications. The APIs covered in this chapter are as follows:

- The Atomics API allows you to protect your code from race conditions resulting from multi-threaded memory access patterns.
- The `postMessage()` API provides the ability to send messages across documents from different origins while keeping the security of the same-origin policy intact.
- The Encoding API enables you to seamlessly convert between strings and buffers—an increasingly common pattern.
- The File API affords you robust tools for sending, receiving, and reading large binary objects.
- The media elements `<audio>` and `<video>` have their own APIs for interacting with the audio and video. Not all media formats are supported by all browsers, so make use of the `canPlayType()` method to properly detect browser support.
- The Drag-and-Drop API allows you to easily indicate that an element is draggable and responds as the operating system does to drops. You can create custom draggable elements and drop targets.
- The Notifications API gives you a browser-independent way of presenting interactive tiles to the user.
- The Streams API affords an entirely new way of incrementally reading, writing, and processing data.
- The Timing APIs provide a robust way of measuring latency in and around the browser.
- The Web Components API introduces a gigantic leap forward for element reusability and encapsulation.
- The Web Cryptography API makes cryptographic operations such as random number generation, encrypting, and signing messages first-class citizens.

21

Error Handling and Debugging

WHAT'S IN THIS CHAPTER?

- Understanding browser error reporting
- Handling errors
- Debugging JavaScript code

WROX.COM DOWNLOADS FOR THIS CHAPTER

Please note that all the code examples for this chapter are available as a part of this chapter's code download on the book's website at www.wrox.com/go/projavascript4e on the Download Code tab.

JavaScript has traditionally been known as one of the most difficult programming languages to debug because of its dynamic nature and years without proper development tools. Errors typically resulted in confusing browser messages such as "object expected" that provided little or no contextual information. The third edition of ECMAScript aimed to improve this situation, introducing the `try-catch` and `throw` statements, along with various error types to help developers deal with errors when they occur. A few years later, JavaScript debuggers and debugging tools began appearing for web browsers. By 2008, most web browsers supported some JavaScript debugging capabilities.

Armed with the proper language support and development tools, web developers are now empowered to implement proper error-handling processes and figure out the cause of problems.

BROWSER ERROR REPORTING

All of the major desktop web browsers—Internet Explorer/Edge, Firefox, Safari, Chrome, and Opera—have some way to report JavaScript errors to the user. By default, all browsers hide this information, both because it’s of little use to anyone but the developer, and because it’s the nature of web pages to throw errors during normal operation.

Desktop Consoles

All modern desktop web browsers expose errors through their web console. These errors can be revealed in the developer tools console. In all the previously mentioned browsers, they share a common path to accessing the web console. Perhaps the easiest way to view errors is to right-click on the web page, select Inspect or Inspect Element, and click the Console tab.

To proceed directly to the console, different operating systems and browsers support different key combinations:

BROWSER	WINDOWS/LINUX	MAC
Chrome	Ctrl+Shift+J	Cmd+Opt+J
Firefox	Ctrl+Shift+K	Cmd+Opt+K
Internet Explorer/Edge	F12, then Ctrl+2	NA
Opera	Ctrl+Shift+I	Cmd+Opt+I
Safari	NA	Cmd+Opt+C

Mobile Consoles

Natively, mobile phones will not offer a console interface directly on the device. However, there are several options for you to use in situations where you would like to inspect errors that are thrown on a mobile device.

Chrome for mobile and Safari on iOS come bundled with utilities that allow you to connect the device to a host operating system running that same browser, and you can then view the errors thrown through the paired desktop browser. This involves physically connecting the device and following the setup instructions for Chrome (<https://developers.google.com/web/tools/chrome-devtools/remote-debugging/>) or Safari (https://developer.apple.com/library/content/documentation/AppleApplications/Conceptual/Safari_Developer_Guide/GettingStarted/GettingStarted.html).

It’s also possible to use a third-party utility to debug directly on the mobile device. A commonly used utility for debugging Firefox is Firebug Lite (https://getfirebug.com/firebuglite_mobile). This works by shimming the Firebug script into the current web page using a JavaScript bookmarklet. Once the script runs, you’ll be able to open a debug interface right on the mobile browser. Firebug Lite also has versions for different browsers such as Chrome (<http://getfirebug.com/releases/lite/chrome/>).

ERROR HANDLING

No one doubts the importance of error handling in programming. Every major web application needs a good error-handling protocol and most good applications have one, though it is typically on the server side of the application. In fact, great care is usually taken by the server-side team to define an error-logging mechanism that categorizes errors by type, frequency, and any other metric that may be important. The result is the ability to understand how the application is working in the public with a simple database query or report-generating script.

Error handling has slowly been adopted on the browser side of web applications even though it is just as important. An important fact to understand is that most people who use the web are not technically savvy—most don't even fully comprehend what a web browser is, let alone which one they're using. As described earlier in this chapter, each browser behaves a little bit differently when a JavaScript error occurs. The default browser experience for JavaScript errors is horrible for the end user. In the best case, the user has no idea what happened and will try again; in the worst case, the user gets incredibly annoyed and never comes back. Having a good error-handling strategy keeps your users informed about what is going on without scaring them. To accomplish this, you must understand the various ways that you can trap and deal with JavaScript errors as they occur.

The try-catch Statement

ECMA-262, third edition, introduced the `try-catch` statement as a way to handle exceptions in JavaScript. The basic syntax is as follows, which is the same as the `try-catch` statement in Java:

```
try {
  // code that may cause an error
} catch (error) {
  // what to do when an error occurs
}
```

Any code that might possibly throw an error should be placed in the `try` portion of the statement, and the code to handle the error is placed in the `catch` portion, as shown in the following example:

```
try {
  window.someNonexistentFunction();
} catch (error) {
  console.log("An error happened!");
}
```

If an error occurs at any point in the `try` portion of the statement, code execution immediately exits and resumes in the `catch` portion. The `catch` portion of the statement receives an object containing information about the error that occurred. Unlike other languages, you must define a name for the error object even if you don't intend to use it. The exact information available on this object varies from browser to browser but contains, at a minimum, a `message` property that holds the error message. ECMA-262 also specifies a `name` property that defines the type of error; this property is available in all current browsers. You can, therefore, display the actual browser message if necessary, as shown in the following example:

```
try {
  window.someNonexistentFunction();
} catch (error) {
  console.log(error.message);
}
```

This example uses the `message` property when displaying an error message to the user. The `message` property is the only one that is guaranteed to be there across Internet Explorer, Firefox, Safari, Chrome, and Opera, even though each browser adds other information. Internet Explorer adds a `description` property, which is always equal to the `message`, as well as a `number` property, which gives an internal error number. Firefox adds `fileName`, `lineNumber`, and `stack` (which contains a stack trace). Safari adds `line` (for the line number), `sourceId` (an internal error code), and `sourceURL`. Once again, it is best to rely only on the `message` property for cross-browser compatibility.

The finally Clause

The optional `finally` clause of the `try-catch` statement always runs its code no matter what. If the code in the `try` portion runs completely, the `finally` clause executes; if there is an error and the `catch` portion executes, the `finally` portion still executes. There is literally nothing that can be done in the `try` or `catch` portion of the statement to prevent the code in `finally` from executing, which includes using a `return` statement. Consider the following function:

```
function testFinally(){
  try {
    return 2;
  } catch (error){
    return 1;
  } finally {
    return 0;
  }
}
```

This function simply places a `return` statement in each portion of the `try-catch` statement. It looks like the function should return 2 because that is in the `try` portion and wouldn't cause an error. However, the presence of the `finally` clause causes that `return` to be ignored; the function returns 0 when called no matter what. If the `finally` clause were removed, the function would return 2. If `finally` is provided, then `catch` becomes optional (only one or the other is required).

NOTE *It's very important to understand that any `return` statements in either the `try` or the `catch` portion will be ignored if a `finally` clause is also included in your code. Be sure to double-check the intended behavior of your code when using `finally`.*

Error Types

Several different types of errors can occur during the course of code execution. Each error type has a corresponding object type that is thrown when an error occurs. ECMA-262 defines the following eight error types:

- `Error`
- `InternalError`
- `EvalError`

- `RangeError`
- `ReferenceError`
- `SyntaxError`
- `TypeError`
- `URIError`

The `Error` type is the base type from which all other error types inherit. As a result of this, all error types share the same properties (the only methods on error objects are the default object methods). An error of type `Error` is rarely, if ever, thrown by a browser; it is provided mainly for developers to throw custom errors.

The `InternalError` type is thrown when the underlying JavaScript engine throws an exception—for example, when a stack overflow occurs from too much recursion. This is not an error type that you would explicitly handle inside your code; if this error is thrown, chances are very good that your code is doing something incorrect or dangerous and should be fixed.

The `EvalError` type is thrown when an exception occurs while using the `eval()` function. ECMA-262 states that this error is thrown “if value of the `eval` property is used in any way other than a direct call (that is, other than by the explicit use of its name as an `Identifier`, which is the `MemberExpression` in a `CallExpression`), or if the `eval` property is assigned to.” This basically means using `eval()` as anything other than a function call, such as:

```
new eval(); // throws EvalError
eval = foo; // throws EvalError
```

In practice, browsers don’t always throw `EvalError` when they’re supposed to. For example, Firefox and Internet Explorer throw a `TypeError` in the first case but the second succeeds without error. Because of this and the unlikelihood of these patterns being used, it is highly unlikely that you will run into this error type.

A `RangeError` occurs when a number is outside the bounds of its range. For example, this error may occur when an attempt is made to define an array with an unsupported number of items, such as `-20` or `Number.MAX_VALUE`, as shown here:

```
let items1 = new Array(-20); // throws RangeError
let items2 = new Array(Number.MAX_VALUE); // throws RangeError
```

Range errors occur infrequently in JavaScript.

The `ReferenceError` type is used when an object is expected. (This is literally the cause of the famous “object expected” browser error.) This type of error typically occurs when attempting to access a variable that doesn’t exist, as in this example:

```
let obj = x; // throws ReferenceError when x isn't declared
```

A `SyntaxError` object is thrown most often when there is a syntax error in a JavaScript string that is passed to `eval()`, as in this example:

```
eval("a ++ b"); // throws SyntaxError
```

Outside of using `eval()`, the `SyntaxError` type is rarely used, because syntax errors occurring in JavaScript code stop execution immediately.

The `TypeError` type is the most used in JavaScript and occurs when a variable is of an unexpected type or an attempt is made to access a nonexistent method. This can occur for any number of reasons, most often when a type-specific operation is used with a variable of the wrong type. Here are some examples:

```
let o = new 10; // throws TypeError
console.log("name" in true); // throws TypeError
Function.prototype.toString.call("name"); // throws TypeError
```

Type errors occur most frequently with function arguments that are used without their type being verified first.

The last type of error is `URIError`, which occurs only when using the `encodeURIComponent()` or `decodeURIComponent()` with a malformed URI. This error is perhaps the most infrequently observed in JavaScript, because these functions are incredibly robust.

The different error types can be used to provide more information about an exception, allowing appropriate error handling. You can determine the type of error thrown in the `catch` portion of a `try-catch` statement by using the `instanceof` operator, as shown here:

```
try {
  someFunction();
} catch (error) {
  if (error instanceof TypeError) {
    // handle type error
  } else if (error instanceof ReferenceError) {
    // handle reference error
  } else {
    // handle all other error types
  }
}
```

Checking the error type is the easiest way to determine the appropriate course of action in a cross-browser way because the error message contained in the `message` property differs from browser to browser.

Usage of try-catch

When an error occurs within a `try-catch` statement, the browser considers the error to have been handled, and so it won't report it using the mechanisms discussed earlier in this chapter. This is ideal for web applications with users who aren't technically inclined and wouldn't otherwise understand when an error occurs. The `try-catch` statement allows you to implement your own error-handling mechanism for specific error types.

The `try-catch` statement is best used where an error might occur that is out of your control. For example, if you are using a function that is part of a larger JavaScript library, that function may throw errors either purposefully or by mistake. Because you can't modify the library's code, it would be appropriate to surround the call in a `try-catch` statement in case an error does occur and then handle the error appropriately.

It's not appropriate to use a `try-catch` statement if you know an error will occur with your code specifically. For example, if a function will fail when a string is passed in instead of a number, you should check the data type of the argument and act accordingly; there is no need in this case to use a `try-catch` statement.

Throwing Errors

A companion to the `try-catch` statement is the `throw` operator, which can be used to throw custom errors at any point in time. The `throw` operator must be used with a value but places no limitation on the type of value. All of the following lines are legal:

```
throw 12345;
throw "Hello world!";
throw true;
throw { name: "JavaScript" };
```

When the `throw` operator is used, code execution stops immediately and continues only if a `try-catch` statement catches the value that was thrown.

Browser errors can be more accurately simulated by using one of the built-in error types. Each error type's constructor accepts a single argument, which is the exact error message. Here is an example:

```
throw new Error("Something bad happened.");
```

This code throws a generic error with a custom error message. The error is handled by the browser as if it were generated by the browser itself, meaning that it is reported by the browser in the usual way and your custom error message is displayed. You can achieve the same result using the other error types, as shown in these examples:

```
throw new SyntaxError("I don't like your syntax.");
throw new InternalError("I can't do that, Dave.");
throw new TypeError("What type of variable do you take me for?");
throw new RangeError("Sorry, you just don't have the range.");
throw new EvalError("That doesn't evaluate.");
throw new URIError("Uri, is that you?");
throw new ReferenceError("You didn't cite your references properly.");
```

The most often used error types for custom error messages are `Error`, `RangeError`, `ReferenceError`, and `TypeError`.

You can also create custom error types by inheriting from `Error` (discussed in Chapter 6). You should provide both a `name` property and a `message` property on your error type. Here is an example:

```
class CustomError extends Error {
  constructor(message) {
    super(message);
    this.name = "CustomError";
    this.message = message;
  }
}

throw new CustomError("My message");
```

Custom error types that are inherited from `Error` are treated just like any other error by the browser. Creating custom error types is helpful when you will be catching the errors that you throw and need to decipher them from browser-generated errors.

When to Throw Errors

Throwing custom errors is a great way to provide more information about why a function has failed. Errors should be thrown when a particular known error condition exists that won't allow the function to execute properly. That is, the browser will throw an error while executing this function given a certain condition. For example, the following function will fail if the argument is not an array:

```
function process(values) {
    values.sort();

    for (let value of values) {
        if (value > 100) {
            return value;
        }
    }

    return -1;
}
```

If this function is run with a string as the argument, the call to `sort()` fails. Each browser gives a different, though somewhat obtuse, error message, as listed here:

- **Internet Explorer**—Property or method doesn't exist.
- **Firefox**—`values.sort()` is not a function.
- **Safari**—Value undefined (result of expression `values.sort`) is not an object.
- **Chrome**—Object name has no method 'sort'.
- **Opera**—Type mismatch (usually a non-object value used where an object is required).

Although Firefox, Chrome, and Safari at least indicate the part of the code that caused the error, none of the error messages are particularly clear as to what happened or how it could be fixed. When dealing with one function, as in the preceding example, debugging is easy enough to handle with these error messages. However, when you're working on a complex web application with thousands of lines of JavaScript code, finding the source of the error becomes much more difficult.

This is where a custom error with appropriate information will significantly contribute to the maintainability of the code. Consider the following example:

```
function process(values) {
    if (!(values instanceof Array)) {
        throw new Error("process(): Argument must be an array.");
    }

    values.sort();

    for (let value of values) {
        if (value > 100) {
            return value;
        }
    }

    return -1;
}
```

In this rewritten version of the function, an error is thrown if the `values` argument isn't an array. The error message provides the name of the function and a clear description as to why the error occurred. If this error occurred in a complex web application, you would have a much clearer idea of where the real problem is.

When you're developing JavaScript code, critically evaluate each function and the circumstances under which it may fail. A good error-handling protocol ensures that the only errors that occur are the ones that you throw.

Throwing Errors versus try-catch

A common question that arises is when to throw errors versus when to use `try-catch` to capture them. Generally speaking, errors are thrown in the low levels of an application architecture, at a level where not much is known about the ongoing process, and so the error can't really be handled. If you are writing a JavaScript library that may be used in a number of different applications, or even a utility function that will be used in a number of different places in a single application, you should strongly consider throwing errors with detailed information. It is then up to the application to catch the errors and handle them appropriately.

The best way to think about the difference between throwing errors and catching errors is this: you should catch errors only if you know exactly what to do next. The purpose of catching an error is to prevent the browser from responding in its default manner; the purpose of throwing an error is to provide information about why an error occurred.

The error Event

Any error that is not handled by a `try-catch` causes the `error` event to fire on the `window` object. This event was one of the first supported by web browsers, and its format has remained intact for backwards compatibility in all major browsers. An `onerror` event handler doesn't create an event object in any browser. Instead, it receives three arguments: the error message, the URL on which the error occurred, and the line number. In most cases, only the error message is relevant because the URL is the same as the location of the document, and the line number could be for inline JavaScript or code in external files. The `onerror` event handler needs to be assigned using the DOM Level 0 technique shown here because it doesn't follow the DOM Level 2 Events standard format:

```
window.onerror = (message, url, line) => {
  console.log(message);
};
```

When any error occurs, whether browser-generated or not, the `error` event fires, and this event handler executes. Then, the default browser behavior takes over, displaying the error message as it would normally. You can prevent the default browser error reporting by returning `false`, as shown here:

```
window.onerror = (message, url, line) => {
  console.log(message);
  return false;
};
```

By returning `false`, this function effectively becomes a `try-catch` statement for the entire document, capturing all unhandled runtime errors. This event handler is the last line of defense against errors

being reported by the browser and, ideally, should never have to be used. Proper usage of the `try-catch` statement means that no errors reach the browser level and, therefore, should never fire the error event.

NOTE *There is a significant difference between the way browsers handle errors using this event. When the error event occurs in Internet Explorer, normal code execution continues; all variables and data are retained and remain accessible from within the `onerror` event handler. In Firefox, however, normal code execution ends, and all variables and data that existed prior to the error occurring are destroyed, making it difficult to truly evaluate the error.*

Images also support an `error` event. Any time the URL in an image's `src` attribute doesn't return a recognized image format, the `error` event fires. This event follows the DOM format by returning an event object with the image as the target. Here is an example:

```
const image = new Image();

image.addEventListener("load", (event) => {
  console.log("Image loaded!");
});
image.addEventListener("error", (event) => {
  console.log("Image not loaded!");
});

image.src = "doesnotexist.gif"; // does not exist, resource will fail to load
```

In this example, an `alert` is displayed when the image fails to load. It's important to understand that once the `error` event fires, the image download process is already over and will not be resumed.

Error-Handling Strategies

Error-handling strategies have traditionally been confined to the server for web applications. There's often a lot of thought that goes into errors and error handling, including logging and monitoring systems. The point of such tools is to analyze error patterns in the hopes of tracking down the root cause and understanding how many users the error affects.

It is equally important to have an error-handling strategy for the JavaScript layer of a web application. Because any JavaScript error can cause a web page to become unusable, understanding when and why errors occur is vital. Most web-application users are not technical and can easily get confused when something doesn't work as expected. They may reload the page in an attempt to fix the problem, or they may just stop trying. As the developer, you should have a good understanding of when and how the code could fail and have a system to track such issues.

Identify Where Errors Might Occur

The most important part of error handling is to first identify where errors might occur in the code. Since JavaScript is loosely typed and function arguments aren't verified, there are often errors that become apparent only when the code is executed. In general, there are three error categories to watch for:

- Type coercion errors
- Data type errors
- Communication errors

Each of these errors occurs when using specific patterns or not applying sufficient value checking.

Static Code Analyzer

It would be irresponsible to not mention here that an overwhelming abundance of errors you might encounter can be preemptively handled by using a static code analyzer or linter as part of your application build process. There is a terrific list of resources at <https://gist.github.com/listochkin/6250151>. The most commonly used static analyzers are JSHint, JSLint, Google Closure, and TypeScript.

Static code analyzers will require you to annotate your JavaScript with types, function signatures, and other directives that describe how the program will run outside of the base executable code. The analyzer will compare your annotations against various parts of your JavaScript codebase that use each other and make you aware of any potential incompatibilities that might manifest inside the actual runtime.

NOTE *As a codebase grows, you will find that static analyzers become increasingly essential—especially as the number of developers working on the same code increases. All major tech companies that maintain extremely large JavaScript codebases use a robust form of static analysis as part of their build processes.*

Type Coercion Errors

Type coercion errors occur as the result of using an operator or other language construct that automatically changes the data type of a value. The two most common type coercion errors occur as a result of using the equal (`==`) or not equal (`!=`) operator and using a non-Boolean value in a flow control statement, such as `if`, `for`, and `while`.

The equal and not equal operators, discussed in Chapter 3, automatically convert values of different types before performing a comparison. Since the same symbols typically perform straight

comparisons in nondynamic languages, developers often mistakenly use them in JavaScript in the same way. In most cases, it's best to use the identically equal (`===`) and not identically equal (`!==`) operators to avoid type coercion. Here is an example:

```
console.log(5 == "5");    // true
console.log(5 === "5");  // false
console.log(1 == true);  // true
console.log(1 === true); // false
```

In this code, the number `5` and the string `"5"` are compared using the equal operator and the identically equal operator. The equal operator first converts the string `"5"` into the number `5` and then compares it with the other number `5`, resulting in `true`. The identically equal operator notes that the two data types are different and simply returns `false`. The same occurs with the values `1` and `true`: they are considered equal by the equal operator but not equal using the identically equal operator. Using the identically equal and not identically equal operators can prevent type coercion errors that occur during comparisons and are highly recommended over using the equal and not equal operators.

NOTE *Codebase style guides will often assert how `===` vs. `==` should be applied. Some style guides subscribe to the notion that if `===` is always used for comparison, type coercion is a non-issue. Others dictate that an unflinching utilization of `==` is overkill in all places except for ones in which string/Boolean coercion is possible.*

Type coercion errors also occur in flow control statements. Statements such as `if` automatically convert any value into a Boolean before determining the next step. The `if` statement, specifically, is often used in error-prone ways. Consider the following example:

```
function concat(str1, str2, str3) {
  let result = str1 + str2;
  if (str3) { // avoid!!!
    result += str3;
  }
  return result;
}
```

This function's intended purpose is to concatenate two or three strings and return the result. The third string is an optional argument and so must be checked. As mentioned in Chapter 3, named variables that aren't used are automatically assigned the value of `undefined`. The value `undefined` converts into the Boolean value `false`, so the intent of the `if` statement in this function is to concatenate the third argument only if it is provided. The problem is that `undefined` is not the only value that gets converted to `false`, and a string is not the only value that gets converted to `true`. If the third argument is the number `0`, for example, the `if` condition fails, while a value of `1` causes the condition to pass.

Using non-Boolean values as conditions in a flow control statement is a very common cause of errors. To avoid such errors, always make sure that a Boolean value is passed as the condition. This is most

often accomplished by doing a comparison of some sort. For example, the previous function can be rewritten as shown here:

```
function concat(str1, str2, str3){
  let result = str1 + str2;
  if (typeof str3 === "string") { // proper comparison
    result += str3;
  }
  return result;
}
```

In this updated version of the function, the `if` statement condition returns a Boolean value based on a comparison. This function is much safer and is less affected by incorrect values.

Data Type Errors

Because JavaScript is loosely typed, variables and function arguments aren't compared to ensure that the correct type of data is being used. It is up to you, as the developer, to do an appropriate amount of data type checking to ensure that an error will not occur. Data type errors most often occur as a result of unexpected values being passed into a function.

In the previous example, the data type of the third argument is checked to ensure that it's a string, but the other two arguments aren't checked at all. If the function must return a string, then passing in two numbers and omitting the third argument easily breaks it. A similar situation is present in the following function:

```
// unsafe function, any non-string value causes an error
function getQueryString(url) {
  const pos = url.indexOf("?");
  if (pos > -1){
    return url.substring(pos +1);
  }
  return "";
}
```

The purpose of this function is to return the query string of a given URL. To do so, it first looks for a question mark in the string using `indexOf()` and, if found, returns everything after the question mark using the `substring()` method. The two methods used in this example are specific to strings, so any other data type that is passed in will cause an error. The following simple type check makes this function less error prone:

```
function getQueryString(url) {
  if (typeof url === "string") { // safer with type check
    let pos = url.indexOf("?");
    if (pos > -1) {
      return url.substring(pos +1);
    }
  }
  return "";
}
```

In this rewritten version of the function, the first step is to check that the value passed in is actually a string. This ensures that the function will never cause an error because of a nonstring value.

As discussed in the previous section, using non-Boolean values as conditions for flow control statements is a bad idea because of type coercion. This is also a bad practice that can cause data type errors. Consider the following function:

```
// unsafe function, non-array values cause an error
function reverseSort(values) {
  if (values) { // avoid!!!
    values.sort();
    values.reverse();
  }
}
```

The `reverseSort()` function sorts an array in reverse order, using both the `sort()` and the `reverse()` methods. Because of the control condition in the `if` statement, any nonarray value that converts to `true` will cause an error. Another common mistake is to compare the argument against `null`, as in this example:

```
// still unsafe, non-array values cause an error
function reverseSort(values) {
  if (values != null){ // avoid!!!
    values.sort();
    values.reverse();
  }
}
```

Comparing a value against `null` only protects the code from two values: `null` and `undefined` (which are equivalent to using the equal and not equal operators). A `null` comparison doesn't do enough to ensure that the value is appropriate; therefore, this technique should be avoided. It's also recommended that you don't compare a value against `undefined`, for the same reason.

Another poor choice is to use feature detection for only one of the features being used. Here is an example:

```
// still unsafe, non-array values cause an error
function reverseSort(values) {
  if (typeof values.sort === "function") { // avoid!!!
    values.sort();
    values.reverse();
  }
}
```

In this example, the code checks for the existence of a `sort()` method on the argument. This leaves open the possibility that an object may be passed in with a `sort()` function that is not an array, in which case the call to `reverse()` causes an error. When you know the exact type of object that is expected, it's best to use `instanceof`, as shown in the following example, to determine that the value is of the right type:

```
// safe, non-array values are ignored
function reverseSort(values) {
  if (values instanceof Array) { // fixed
    values.sort();
    values.reverse();
  }
}
```

This last version of `reverseSort()` is safe—it tests the `values` argument to see if it’s an instance of `Array`. In this way, the function is assured that any nonarray values are ignored.

Generally speaking, values that should be primitive types should be checked using `typeof`, and values that should be objects should be checked using `instanceof`. Depending on how a function is being used, it may not be necessary to check the data type of every argument, but any public-facing APIs should definitely perform type checking to ensure proper execution.

Communication Errors

Since the advent of Ajax programming, it has become quite common for web applications to dynamically load information or functionality throughout the application’s life cycle. Any communication between JavaScript and the server is an opportunity for an error to occur.

The first type of communication error involves malformed URLs or post data. This typically occurs when data isn’t encoded using `encodeURIComponent()` before being sent to the server. The following URL, for example, isn’t formed correctly:

```
http://www.yourdomain.com/?redir=http://www.someotherdomain.com?a=b&c=d
```

This URL can be fixed by using `encodeURIComponent()` on everything after `"redir="`, which produces the following result:

```
http://www.example.com/?redir=http%3A%2F%2Fwww.someotherdomain.com%3Fa%3Db%26c%3Dd
```

The `encodeURIComponent()` method should always be used for query string arguments. To ensure that this happens, you will find it’s sometimes helpful to define a function that handles query string building, such as the following:

```
function addQueryStringArg(url, name, value) {
  if (url.indexOf("?") == -1) {
    url += "?";
  } else {
    url += "&";
  }

  url += '${encodeURIComponent(name)}=${encodeURIComponent(value)}';
  return url;
}
```

This function accepts three arguments: the URL to append the query string argument to, the name of the argument, and the argument value. If the URL that’s passed in doesn’t contain a question mark, then one is added; otherwise, an ampersand is added because this means there are other query string arguments. The query string name and value are then encoded and added to the URL. The function can be used as in the following example:

```
const url = "http://www.somedomain.com";
const newUrl = addQueryStringArg(url, "redir",
  "http://www.someotherdomain.com?a=b&c=d");
console.log(newUrl);
```

Using this function instead of manually building URLs can ensure proper encoding and avoid errors related to it.

Communication errors also occur when the server response is not as expected. When using dynamic script loading or dynamic style loading, there is the possibility that the requested resource is not available. Some browsers fail silently when a resource isn't returned, whereas others error out. Unfortunately, there is little you can do when using these techniques to determine that an error has occurred. In some cases, using Ajax communication can provide additional information about error conditions.

Distinguishing between Fatal and Nonfatal Errors

One of the most important parts of any error-handling strategy is to determine whether or not an error is fatal. One or more of the following identifies a nonfatal error:

- It won't interfere with the user's main tasks.
- It affects only a portion of the page.
- Recovery is possible.
- Repeating the action may result in success.

In essence, nonfatal errors aren't a cause for concern. For example, Gmail (<https://mail.google.com>) has a feature that allows users to send Hangouts messages from the interface. If, for some reason, Hangouts don't work, it's a nonfatal error because that is not the application's primary function. The primary use case for Gmail is to read and write e-mail messages, and as long as the user can do that, there is no reason to interrupt the user experience. Nonfatal errors don't require you to send an explicit message to the user. You may be able to replace the area of the page that is affected with a message indicating that the functionality isn't available, but it's not necessary to interrupt the user.

Fatal errors, on the other hand, are identified by one or more of the following:

- The application absolutely cannot continue.
- The error significantly interferes with the user's primary objective.
- Other errors will occur as a result.

It's vitally important to understand when a fatal error occurs in JavaScript so appropriate action can be taken. When a fatal error occurs, you should send a message to the users immediately to let them know that they will not be able to continue what they were doing. If the page must be reloaded for the application to work, then you should tell the user this and provide a button that automatically reloads the page.

You must also make sure that your code doesn't dictate what is and is not a fatal error. Nonfatal and fatal errors are primarily indicated by their affect on the user. Good code design means that an error in one part of the application shouldn't unnecessarily affect another part that, in reality, isn't related at all. For example, consider a personalized home page, such as Gmail (<https://mail.google.com>), that has multiple independent modules on the page. If each module has to be initialized using a JavaScript call, you may see code that looks something like this:

```
for (let mod of mods){  
    mod.init(); // possible fatal error  
}
```

On its surface, this code appears fine: the `init()` method is called on each module. The problem is that an error in any module's `init()` method will cause all modules that come after it in the array

to never be initialized. If the error occurs on the first module, then none of the modules on the page will be initialized. Logically, this doesn't make sense because each module is an independent entity that isn't reliant on any other module for its functionality. It's the structure of the code that makes this type of error fatal. Fortunately, the code can be rewritten as follows to make an error in any one module nonfatal:

```
for (let mod of mods){
  try {
    mod.init();
  } catch (ex){
    // handle error here
  }
}
```

By adding a `try-catch` statement into the `for` loop, any error when a module initializes will not prevent other modules from initializing. When an error occurs in this code, it can be handled independently and in a way that doesn't interfere with the user experience.

Log Errors to the Server

A common practice in web applications is to have a centralized error log where important errors are written for tracking purposes. Database and server errors are regularly written to the log and categorized through some common API. With complex web applications, it's recommended that you also log JavaScript errors back to the server. The idea is to log the errors into the same system used for server-side errors and categorize them as having come from the front end. Using the same system allows for the same analytics to be performed on the data regardless of the error's source.

To set up a JavaScript error-logging system, you'll first need a page or entry point on the server that can handle the error data. The page need not do anything more than take data from the query string and save it to an error log. This page can then be used with code such as the following:

```
function logError(sev, msg) {
  let img = new Image(),
      encodedSev = encodeURIComponent(sev),
      encodedMsg = encodeURIComponent(msg);
  img.src = 'log.php?sev=${encodedSev}&msg=${encodedMsg}';
}
```

The `logError()` function accepts two arguments: a severity and the error message. The severity may be numbers or strings, depending on the system you're using. An `Image` object is used to send the request because of its flexibility, as described here:

- The `Image` object is available in all browsers, even those that don't support the `XMLHttpRequest` object.
- Cross-domain restrictions don't apply. Often there is one server responsible for handling error logging from multiple servers, and `XMLHttpRequest` would not work in that situation.
- There's less chance that an error will occur in the process of logging the error. Most Ajax communication is handled through functionality wrappers provided by JavaScript libraries. If that library's code fails, and you're trying to use it to log the error, the message may never get logged.

Whenever a `try-catch` statement is used, it's likely that the error should be logged. Here is an example:

```
for (let mod of mods){
  try {
    mod.init();
  } catch (ex){
    logError("nonfatal", 'Module init failed: ${ex.message}');
  }
}
```

In this code, `logError()` is called when a module fails to initialize. The first argument is `"nonfatal"`, indicating the severity of the error, and the message provides contextual information plus the true JavaScript error message. Error messages that are logged to the server should provide as much contextual information as possible to help identify the exact cause of the error.

DEBUGGING TECHNIQUES

Before JavaScript debuggers were readily available, developers had to use creative methods to debug their code. This led to the placement of code specifically designed to output debugging information in one or more ways. The most common debugging technique was to insert alerts throughout the code in question, which was both tedious, because it required cleanup after the code was debugged, and annoying if an alert was mistakenly left in code that was used in a production environment. Alerts are no longer recommended for debugging purposes, because several other, more elegant solutions are available.

Logging Messages to a Console

All major browsers have JavaScript consoles that can be used to view JavaScript errors. All three also allow you to write directly to the JavaScript console via the `console` object, which has the following methods:

- `error(message)`—Logs an error message to the console
- `info(message)`—Logs an informational message to the console
- `log(message)`—Logs a general message to the console
- `warn(message)`—Logs a warning message to the console

The message display on the error console differs according to the method that was used to log the message. Error messages contain a red icon, whereas warnings contain a yellow icon. Console messages may be used, as in the following function:

```
function sum(num1, num2){
  console.log('Entering sum(), arguments are ${num1},${num2}');
```

```
console.log("Before calculation");
const result = num1 + num2;
console.log("After calculation");

console.log("Exiting sum()");
return result;
}
```

As the `sum()` function is called, several messages are output to the JavaScript console to aid in debugging.

Logging messages to the JavaScript console is helpful in debugging code, but all messages should be removed when code goes to production. This can be done automatically, using a code-processing step in deployment, or manually.

NOTE *Logging messages is considered a better debugging method than using alerts, because alerts interrupt program execution, which may affect the result of the code as timing of asynchronous processes are affected. Logging also allows you to print an arbitrary number of arguments and inspect object instances (alerting an object will serialize it to a string before alerting, leading you to all-too-often see `Object[Object]` as the alert message).*

Understanding the Console Runtime

The browser console is a REPL (read-eval-print loop) that is concurrent with the page's JavaScript runtime. It behaves effectively the same way as if the browser were evaluating a newly discovered `<script>` tag inside the DOM. Commands executed from inside the console can access globals and various APIs in the same way that page-level JavaScript can. An arbitrary amount of code can be evaluated from the console; as is the case with any other page-level code it is blocking. Modifications, objects, and callbacks will persist to the DOM and/or runtime.

The JavaScript runtime will restrict what different windows can access, and so in all major browsers you are able to select which window the JavaScript console inputs should execute in. The code you execute does not execute with elevated privilege—it is still subject to cross-origin restrictions and any other controls that are enforced by the browser.

The console runtime also has developer tool integration that offers you some contextual bonus tools to help with debugging that are not available in normal JavaScript. One of the most useful tools is the last-clicked selector, which is available in some form in all major browsers. In the Element tab inside the developer tools, when you click a node in the DOM tree, you gain a reference to the JavaScript instance of that node inside the Console tab by using `$0`. It behaves as a normal JavaScript instance, so reading properties such as `$0.scrollWidth` and invoking member methods such as `$0.remove()` are allowed.

Using the JavaScript Debugger

Also available to you in all major browsers is the JavaScript debugger. As part of the ECMAScript 5.1 specification, the `debugger` keyword will attempt to invoke any available debugging functionality. If there is no associated behavior, this statement will be silently skipped as a no-op. The statement can be used as follows:

```
function pauseExecution() {
  console.log("Will print before breakpoint");
  debugger;
  console.log("Will not print until breakpoint continues");
}
```

When the runtime encounters the keyword, in all major browsers it will open the developer tools panel with a breakpoint set at that exact point. You will then be able to use a separate browser console that executes code at the specific lexical scope in which the breakpoint is currently stopped. Additionally, you will be able to perform standard code debugger operations (step into, step over, continue, and so on).

Browsers will also commonly allow you to set breakpoints manually (without using the debugger keyword statement) by inspecting the actual loaded JavaScript code inside the developer tools and selecting the line at which you would like to set the breakpoint. This set breakpoint will behave in the same way, but it will not persist through browser sessions.

Logging Messages to the Page

Another common way to log debugging messages is to specify an area of the page that messages are written to. This may be an element that is included all the time but only used for debugging purposes, or an element that is created only when necessary. For example, the `log()` function may be changed to the following:

```
function log(message) {
  // Lexical scope of this function will use the following instance
  // instead of window.console
  const console = document.getElementById("debuginfo");
  if (console === null) {
    console = document.createElement("div");
    console.id = "debuginfo";
    console.style.background = "#dedede";
    console.style.border = "1px solid silver";
    console.style.padding = "5px";
    console.style.width = "400px";
    console.style.position = "absolute";
    console.style.right = "0px";
    console.style.top = "0px";
    document.body.appendChild(console);
  }
  console.innerHTML += '<p> ${message}</p>';
}
```

In this new version of `log()`, the code first checks to see if the debugging element already exists. If not, then a new `<div>` element is created and assigned stylistic information to separate it from the rest of the page. After that, the message is written into the `<div>` using `innerHTML`. The result is a small area that displays log information on the page.

NOTE *As with console logging, page-logging code should be removed before the code is used in a production environment.*

Shimming Console Methods

It is burdensome to a developer to remember to use two different types of log statements—the native `console.log()`, and a separately defined custom `log()`. Because `console` is a global object with writable member methods, it is completely possible to overwrite its member methods with custom behavior and allow log statements sprinkled throughout the codebase to happily log to whatever you have defined.

You can define a shim as follows:

```
// Join all arguments into string and alert the result
console.log = function() {
  // 'arguments' does not have a join method, first convert arguments to array
  const args = Array.prototype.slice.call(arguments);
  console.log(args.join(', '));
}
```

Now, this will be invoked instead of the conventional log behavior. This modification will not persist a page reload so it is a useful and lightweight strategy for debugging or log interception.

Throwing Errors

As mentioned earlier, throwing errors is an excellent way to debug code. If your error messages are specific enough, just seeing the error as it's reported may be enough to determine the error's source. The key to good error messages is for them to provide exact details about the cause of the error so that additional debugging is minimal. Consider the following function:

```
function divide(num1, num2) {
  return num1 / num2;
}
```

This simple function divides two numbers but will return `NaN` if either of the two arguments isn't a number. Simple calculations often cause problems in web applications when they return `NaN` unexpectedly. In this case, you can check that the type of each argument is a number before attempting the calculation. Consider the following example:

```
function divide(num1, num2) {
  if (typeof num1 !== "number" || typeof num2 !== "number"){
```

```
        throw new Error("divide(): Both arguments must be numbers.");
    }
    return num1 / num2;
}
```

Here, an error is thrown if either of the two arguments isn't a number. The error message provides the name of the function and the exact cause of the error. When the browser reports this error message, it immediately gives you a place to start looking for problems and a basic summary of the issue. This is much easier than dealing with a nonspecific browser error message.

In large applications, custom errors are typically thrown using an `assert()` function. Such a function takes a condition that should be true and throws an error if the condition is false. The following is a very basic `assert()` function:

```
function assert(condition, message) {
    if (!condition) {
        throw new Error(message);
    }
}
```

The `assert()` function can be used in place of multiple `if` statements in a function and can be a good location for error logging. This function can be used as follows:

```
function divide(num1, num2) {
    assert(typeof num1 == "number" && typeof num2 == "number",
        "divide(): Both arguments must be numbers.");
    return num1 / num2;
}
```

Using an `assert()` function reduces the amount of code necessary to throw custom errors and makes the code more readable compared to the previous example.

COMMON LEGACY INTERNET EXPLORER ERRORS

Internet Explorer has traditionally been one of the most difficult browsers in which to debug JavaScript errors. Legacy versions of the browser throw error messages that are generally short and confusing, with little or no context given. The following sections provide a list of common and difficult-to-debug JavaScript errors that may occur in legacy versions of Internet Explorer. Because these browsers do not support ES6, the code will be backwards compatible.

Invalid Character

The syntax of a JavaScript file must be made up of certain characters. When an invalid character is detected in a JavaScript file, IE throws the "invalid character" error. An invalid character is any character not defined as part of JavaScript syntax. For example, there is a character that looks like a minus sign but is represented by the Unicode value 8211 (`\u2013`). This character cannot be used in place of a regular minus sign (ASCII code 45) because it's not part of JavaScript syntax. This special character is often automatically inserted into Microsoft Word documents, so you will get an illegal character error if you were to copy code written in Word to a text editor and then run it in

Internet Explorer. Other browsers react similarly. Firefox throws an "illegal character" error, Safari reports a syntax error, and Opera reports a `ReferenceError`, because it interprets the character as an undefined identifier.

Member Not Found

As mentioned previously, all DOM objects in Internet Explorer are implemented as COM objects rather than in native JavaScript. This can result in some very strange behavior when it comes to garbage collection. The "member not found" error is the direct result of the mismatched garbage collection routines in Internet Explorer.

This error typically occurs when you're trying to assign a value to an object property after the object has already been destroyed. The object must be a COM object to get this specified error message. The best example of this occurs when you are using the `event` object. The Internet Explorer `event` object exists as a property of `window` and is created when the event occurs and destroyed after the last event handler has been executed. So if you were to use the `event` object in a closure that was to be executed later, any attempt to assign to a property of `event` will result in this error, as in the following example:

```
document.onclick = function() {
    var event = window.event;
    setTimeout(function() {
        event.returnValue = false; // member not found error
    }, 1000);
};
```

In this code, a click handler is assigned to the document. It stores a reference to `window.event` in a local variable named `event`. This `event` variable is then referenced in a closure that is passed into `setTimeout()`. When the `onclick` event handler is exited, the `event` object is destroyed, so the reference in the closure is to an object whose members no longer exist. Assigning a value to `returnValue` causes the "member not found" error because you cannot write to a COM object that has already destroyed its members.

Unknown Runtime Error

An unknown runtime error occurs when HTML is assigned using the `innerHTML` or `outerHTML` property in one of the following ways: if a block element is being inserted into an inline element or you're accessing either property on any part of a table (`<table>`, `<tbody>`, and so on). For example, a `<p>` tag cannot technically contain a block-level element such as a `<div>`, so the following code will cause an unknown runtime error:

```
p.innerHTML = "<div>Hi</div>"; // where p contains a <p> element
```

Other browsers attempt to error-correct when block elements are inserted in invalid places so that no error occurs, but Internet Explorer is much stricter in this regard.

Syntax Error

Often when Internet Explorer reports a syntax error, the cause is immediately apparent. You can usually trace back the error to a missing semicolon or an errant closing brace. However, there is another instance where a syntax error occurs that may not be immediately apparent.

If you are referencing an external JavaScript file that for some reason returns non-JavaScript code, Internet Explorer throws a syntax error. For example, if you set the `src` attribute of a `<script>` to point to an HTML file, a syntax error occurs. The syntax error is typically reported as the first line and first character of a script. Opera and Safari report a syntax error as well, but they will also report the referenced file that caused the problem. Internet Explorer gives no such information, so you need to double-check every externally referenced JavaScript file. Firefox simply ignores any parsing errors in a non-JavaScript file that's included as if it were JavaScript.

This type of error typically occurs when JavaScript is being dynamically generated by a server-side component. Many server-side languages automatically insert HTML into the output if a runtime error occurs, and such output clearly breaks JavaScript syntax. If you're having trouble tracking down a syntax error, double-check each external JavaScript file to be sure that it doesn't contain HTML inserted by the server because of an error.

The System Cannot Locate the Resource Specified

Perhaps one of the least useful error messages is "The system cannot locate the resource specified." This error occurs when JavaScript is used to request a resource by URL and the URL is longer than Internet Explorer's maximum URL length of 2083 characters. This URL length limit applies not just to JavaScript but also to Internet Explorer in general. (Other browsers do not limit URL length so tightly.) There is also a URL path limit of 2048 characters. The following example causes this error:

```
function createLongUrl(url) {
    var s = "?";
    for (var i = 0, len = 2500; i < len; i++){
        s += "a";
    }

    return url + s;
}

var x = new XMLHttpRequest();
x.open("get", createLongUrl("http://www.somedomain.com/"), true);
x.send(null);
```

In this code, the `XMLHttpRequest` object attempts to make a request to a URL that exceeds the maximum URL limit. The error occurs when `open()` is called. One workaround for this type of error is to shorten the query string necessary for the request to succeed, either by decreasing the size of the named query string arguments or by eliminating unnecessary data. Another workaround is to change the request to a `POST` and send the data as the request body instead of in the query string.

SUMMARY

Error handling in JavaScript is critical for today's complex web applications. Failing to anticipate where errors might occur and how to recover from them can lead to a poor user experience and possibly frustrated users. Most browsers don't report JavaScript errors to users by default, so you need to enable error reporting when developing and debugging. In production, however, no errors should ever be reported this way.

The following methods can be used to prevent the browser from reacting to a JavaScript error:

- The `try-catch` statement can be used where errors may occur, giving you the opportunity to respond to errors in an appropriate way instead of allowing the browser to handle the error.
- Another option is to use the `window.onerror` event handler, which receives all errors that are not handled by a `try-catch` (Internet Explorer, Firefox, and Chrome only).

Each web application should be inspected to determine where errors might occur and how those errors should be dealt with.

- A determination as to what constitutes a fatal error or a nonfatal error needs to be made ahead of time.
- After that, code can be evaluated to determine where the most likely errors will occur. Errors commonly occur in JavaScript because of the following factors:
 - Type coercion
 - Insufficient data type checking
 - Incorrect data being sent to or received from the server

Internet Explorer, Firefox, Chrome, Opera, and Safari each have JavaScript debuggers that either come with the browser or can be downloaded as an add-on. Each debugger offers the ability to set breakpoints, control code execution, and inspect the value of variables at runtime.

22

XML in JavaScript

WHAT'S IN THIS CHAPTER?

- Examining XML DOM support in browsers
- Understanding XPath in JavaScript
- Using XSLT processors

At one point in time, XML was the standard for structured data storage and transmission over the Internet. The evolution of XML closely mirrored the evolution of web technologies, as the DOM was developed for use not just in web browsers but also in desktop and server applications for dealing with XML data structures. Many developers started writing their own XML parsers in JavaScript to deal with the lack of built-in solutions. Since that time, all browsers have introduced native support for XML, the XML DOM, and many related technologies.

XML DOM SUPPORT IN BROWSERS

Because browser vendors began implementing XML solutions before formal standards were created, each offers not only different levels of support but also different implementations. DOM Level 2 was the first specification to introduce the concept of dynamic XML DOM creation. This capability was expanded in DOM Level 3 to include parsing and serialization. By the time DOM Level 3 was finalized, however, most browsers had implemented their own solutions.

DOM Level 2 Core

As mentioned in Chapter 12, DOM Level 2 introduced the `createDocument()` method of `document.implementation`. You may recall that it's possible to create a blank XML document using the following syntax:

```
let xmldom = document.implementation.createDocument(namespaceUri, root, doctype);
```

When dealing with XML in JavaScript, the `root` argument is typically the only one that is used because this defines the tag name of the XML DOM's `document` element. The `namespaceUri` argument is used sparingly because namespaces are difficult to manage from JavaScript. The `doctype` argument is rarely, if ever, used.

To create a new XML document with `document` element of `<root>`, you can use the following code:

```
let xmldom = document.implementation.createDocument("", "root", null);

console.log(xmldom.documentElement.tagName); // "root"

let child = xmldom.createElement("child");
xmldom.documentElement.appendChild(child);
```

This example creates an XML DOM document with no default namespace and no `doctype`. Note that even though a namespace and `doctype` aren't needed, the arguments must still be passed in. An empty string is passed as the namespace URI so that no namespace is applied, and `null` is passed as the `doctype`. The `xmldom` variable contains an instance of the DOM Level 2 `Document` type, complete with all of the DOM methods and properties discussed in Chapter 12. In this example, the `document` element's tag name is displayed and then a new `child` element is created and added.

You can check to see if DOM Level 2 XML support is enabled in a browser by using the following line of code:

```
let hasXmlDom = document.implementation.hasFeature("XML", "2.0");
```

In practice, it is rare to create an XML document from scratch and then build it up systematically using DOM methods. It is much more likely that an XML document needs to be parsed into a DOM structure, or vice versa. Because DOM Level 2 didn't provide for such functionality, a couple of de facto standards emerged.

The DOMParser Type

Firefox introduced the `DOMParser` type specifically for parsing XML into a DOM document, and it was later adopted by all other browser vendors. To use it, you must first create an instance of `DOMParser` and then call the `parseFromString()` method. This method accepts two arguments: the XML string to parse and a content type, which should always be `"text/xml"`. The return value is an instance of `Document`. Consider the following example:

```
let parser = new DOMParser();
let xmldom = parser.parseFromString("<root><child/></root>", "text/xml");

console.log(xmldom.documentElement.tagName); // "root"
console.log(xmldom.documentElement.firstChild.tagName); // "child"
```



```

let anotherChild = xmldom.createElement("child");
xmldom.documentElement.appendChild(anotherChild);

let children = xmldom.getElementsByTagName("child");
console.log(children.length); // 2

```

In this example, a simple XML string is parsed into a DOM document. The DOM structure has `<root>` as the document element with a single `<child>` element as its child. You can then interact with the returned document using DOM methods.

The `DOMParser` can parse only well-formed XML and, as such, cannot parse HTML into an HTML document. Unfortunately, browsers behave differently when a parsing error occurs. When a parsing error occurs in Firefox, Opera, Safari, and Chrome, a `Document` object is still returned from `parseFromString()`, but its document element is `<parsererror>` and the content of the element is a description of the parsing error. Here is an example:

```

<parsererror xmlns="http://www.mozilla.org/newlayout/xml/parsererror.xml">XML
Parsing Error: no element found Location: file:///I:/My%20Writing/My%20Books/
Professional%20JavaScript/Second%20Edition/Examples/Ch15/DOMParserExample2.js Line
Number 1, Column 7:<sourcetext>&lt;root&gt; ; -----^</sourcetext></parsererror>

```

Firefox and Opera both return documents in this format. Safari and Chrome return a document that has a `<parsererror>` element embedded at the point where the parsing error occurred. Early Internet Explorer versions throw a parsing error at the point where `parseFromString()` is called. Because of these differences, the best way to determine if a parsing error has occurred is to use a `try-catch` block, and if there's no error, look for a `<parsererror>` element anywhere in the document via `getElementsByTagName()`, as shown here:

```

let parser = new DOMParser(),
    xmldom,
    errors;
try {
    xmldom = parser.parseFromString("<root>", "text/xml");
    errors = xmldom.getElementsByTagName("parsererror");
    if (errors.length > 0) {
        throw new Error("Parsing error!");
    }
} catch (ex) {
    console.log("Parsing error!");
}

```

In this example, the string to be parsed is missing a closing `</root>` tag, which causes a parse error. In Internet Explorer, this throws an error. In Firefox and Opera, the `<parsererror>` element will be the document element, whereas it's the first child `<root>` in Chrome and Safari. The call to `getElementsByTagName("parsererror")` covers both cases. If any elements are returned by this method call, then an error has occurred and an alert is displayed. You could go one step further and extract the error information from the element as well.

The XMLSerializer Type

As a companion to `DOMParser`, Firefox also introduced the `XMLSerializer` type to provide the reverse functionality: serializing a DOM document into an XML string. Since that time, the `XMLSerializer` has been adopted by all major browser vendors.

To serialize a DOM document, you must create a new instance of `XMLSerializer` and then pass the document into the `serializeToString()` method, as in this example:

```
let serializer = new XMLSerializer();
let xml = serializer.serializeToString(xmlDom);
console.log(xml);
```

The value returned from `serializeToString()` is a string that is not pretty-printed, so it may be difficult to read with the naked eye.

The `XMLSerializer` is capable of serializing any valid DOM object, which includes individual nodes and HTML documents. When an HTML document is passed into `serializeToString()`, it is treated as an XML document, and so the resulting code is well-formed.

NOTE *If a non-DOM object is passed into the `serializeToString()` method, an error is thrown.*

XPATH SUPPORT IN BROWSERS

XPath was created as a way to locate specific nodes within a DOM document, so it's important to XML processing. An API for XPath wasn't part of a specification until DOM Level 3, which introduced the DOM Level 3 XPath recommendation. Many browsers chose to implement this specification, but Internet Explorer decided to implement support in its own way.

DOM Level 3 XPath

The DOM Level 3 XPath specification defines interfaces to use for evaluating XPath expressions in the DOM. To determine if the browser supports DOM Level 3 XPath, use the following JavaScript code:

```
let supportsXPath = document.implementation.hasFeature("XPath", "3.0");
```

Although there are several types defined in the specification, the two most important ones are `XPathEvaluator` and `XPathResult`. The `XPathEvaluator` is used to evaluate XPath expressions within a specific context. This type has the following three methods:

- `createExpression(expression, nsresolver)`—Computes the XPath expression and accompanying namespace information into an `XPathExpression`, which is a compiled version of the query. This is useful if the same query is going to be run multiple times.
- `createNSResolver(node)`—Creates a new `XPathNSResolver` object based on the namespace information of `node`. An `XPathNSResolver` object is required when evaluating against an XML document that uses namespaces.
- `evaluate(expression, context, nsresolver, type, result)`—Evaluates an XPath expression in the given context and with specific namespace information. The additional arguments indicate how the result should be returned.

The `Document` type is typically implemented with the `XPathEvaluator` interface. So you can either create a new instance of `XPathEvaluator` or use the methods located on the `Document` instance (for both XML and HTML documents).

Of the three methods, `evaluate()` is the most frequently used. This method takes five arguments: the XPath expression, a context node, a namespace resolver, the type of result to return, and an `XPathResult` object to fill with the result (usually `null`, because the result is also returned as the function value). The third argument, the namespace resolver, is necessary only when the XML code uses an XML namespace. If namespaces aren't used, this should be set to `null`. The fourth argument, the type of result to return, is one of the following 10 constants values:

- `XPathResult.ANY_TYPE`—Returns the type of data appropriate for the XPath expression.
- `XPathResult.NUMBER_TYPE`—Returns a number value.
- `XPathResult.STRING_TYPE`—Returns a string value.
- `XPathResult.BOOLEAN_TYPE`—Returns a Boolean value.
- `XPathResult.UNORDERED_NODE_ITERATOR_TYPE`—Returns a node set of matching nodes, although the order may not match the order of the nodes within the document.
- `XPathResult.ORDERED_NODE_ITERATOR_TYPE`—Returns a node set of matching nodes in the order in which they appear in the document. This is the most commonly used result type.
- `XPathResult.UNORDERED_NODE_SNAPSHOT_TYPE`—Returns a node set snapshot, capturing the nodes outside of the document so that any further document modification doesn't affect the node set. The nodes in the node set are not necessarily in the same order as they appear in the document.
- `XPathResult.ORDERED_NODE_SNAPSHOT_TYPE`—Returns a node set snapshot, capturing the nodes outside of the document so that any further document modification doesn't affect the result set. The nodes in the result set are in the same order as they appear in the document.
- `XPathResult.ANY_UNORDERED_NODE_TYPE`—Returns a node set of matching nodes, although the order may not match the order of the nodes within the document.
- `XPathResult.FIRST_ORDERED_NODE_TYPE`—Returns a node set with only one node, which is the first matching node in the document.

The type of result you specify determines how to retrieve the value of the result. Here's a typical example:

```
let result = xmldom.evaluate("employee/name", xmldom.documentElement, null,
    XPathResult.ORDERED_NODE_ITERATOR_TYPE, null);

if (result !== null) {
    let element = result.iterateNext();
    while(element) {
```

```

        console.log(element.tagName);
        node = result.iterateNext();
    }
}

```

This example uses the `XPathResult.ORDERED_NODE_ITERATOR_TYPE` result, which is the most commonly used result type. If no nodes match the XPath expression, `evaluate()` returns `null`; otherwise, it returns an `XPathResult` object. The `XPathResult` has properties and methods for retrieving results of specific types. If the result is a node iterator, whether it be ordered or unordered, the `iterateNext()` method must be used to retrieve each matching node in the result. When there are no further matching nodes, `iterateNext()` returns `null`.

If you specify a snapshot result type (either ordered or unordered), you must use the `snapshotItem()` method and `snapshotLength` property, as in the following example:

```

let result = xmldom.evaluate("employee/name", xmldom.documentElement, null,
    XPathResult.ORDERED_NODE_SNAPSHOT_TYPE, null);
if (result !== null) {
    for (let i = 0, len=result.snapshotLength; i < len; i++) {
        console.log(result.snapshotItem(i).tagName);
    }
}

```

In this example, `snapshotLength` returns the number of nodes in the snapshot, and `snapshotItem()` returns the node in a given position in the snapshot (similar to `length` and `item()` in a `NodeList`).

Single Node Results

The `XPathResult.FIRST_ORDERED_NODE_TYPE` result returns the first matching node, which is accessible through the `singleNodeValue` property of the result. For example:

```

let result = xmldom.evaluate("employee/name", xmldom.documentElement, null,
    XPathResult.FIRST_ORDERED_NODE_TYPE, null);

if (result !== null) {
    console.log(result.singleNodeValue.tagName);
}

```

As with other queries, `evaluate()` returns `null` when there are no matching nodes. If a node is returned, it is accessed using the `singleNodeValue` property. This is the same for `XPathResult.FIRST_ORDERED_NODE_TYPE`.

Simple Type Results

It's possible to retrieve simple, nonnode data types from XPath as well, using the `XPathResult` types of `Boolean`, `number`, and `string`. These result types return a single value using the `booleanValue`, `numberValue`, and `stringValue` properties, respectively. For the `Boolean` type, the evaluation typically returns `true` if at least one node matches the XPath expression and returns `false` otherwise. Consider the following:

```

let result = xmldom.evaluate("employee/name", xmldom.documentElement, null,
    XPathResult.BOOLEAN_TYPE, null);
console.log(result.booleanValue);

```

In this example, if any nodes match "employee/name", the `booleanValue` property is equal to `true`.

For the number type, the XPath expression must use an XPath function that returns a number, such as `count()`, which counts all the nodes that match a given pattern. Here's an example:

```
let result = xmldom.evaluate("count(employee/name)", xmldom.documentElement,
    null, XPathResult.NUMBER_TYPE, null);
console.log(result.numberValue);
```

This code outputs the number of nodes that match "employee/name" (which is 2). If you try using this method without one of the special XPath functions, `numberValue` is equal to `NaN`.

For the string type, the `evaluate()` method finds the first node matching the XPath expression and then returns the value of the first child node, assuming the first child node is a text node. If not, the result is an empty string. Here is an example:

```
let result = xmldom.evaluate("employee/name", xmldom.documentElement, null,
    XPathResult.STRING_TYPE, null);
console.log(result.stringValue);
```

In this example, the code outputs the string contained in the first text node under the first element matching "element/name".

Default Type Results

All XPath expressions automatically map to a specific result type. Setting the specific result type limits the output of the expression. You can, however, use the `XPathResult.ANY_TYPE` constant to allow the automatic result type to be returned. Typically, the result type ends up as a Boolean value, a number value, a string value, or an unordered node iterator. To determine which result type has been returned, use the `resultType` property on the evaluation result, as shown in this example:

```
let result = xmldom.evaluate("employee/name", xmldom.documentElement, null,
    XPathResult.ANY_TYPE, null);

if (result !== null) {
    switch(result.resultType) {
        case XPathResult.STRING_TYPE:
            // handle string type
            break;

        case XPathResult.NUMBER_TYPE:
            // handle number type
            break;

        case XPathResult.BOOLEAN_TYPE:
            // handle boolean type
            break;

        case XPathResult.UNORDERED_NODE_ITERATOR_TYPE:
            // handle unordered node iterator type
            break;

        default:
            // handle other possible result types
    }
}
```

Using the `XPathResult.ANY_TYPE` constant allows more natural use of XPath but may also require extra processing code after the result is returned.

Namespace Support

For XML documents that make use of namespaces, the `XPathEvaluator` must be informed of the namespace information in order to make a proper evaluation. There are a number of ways to accomplish this. Consider the following XML code:

```
<?xml version="1.0" ?>
<wrox:books xmlns:wrox="http://www.wrox.com/">
  <wrox:book>
    <wrox:title>Professional JavaScript for Web Developers</wrox:title>
    <wrox:author>Nicholas C. Zakas</wrox:author>
  </wrox:book>
  <wrox:book>
    <wrox:title>Professional Ajax</wrox:title>
    <wrox:author>Nicholas C. Zakas</wrox:author>
    <wrox:author>Jeremy McPeak</wrox:author>
    <wrox:author>Joe Fawcett</wrox:author>
  </wrox:book>
</wrox:books>
```

In this XML document, all elements are part of the `http://www.wrox.com/` namespace, identified by the `wrox` prefix. If you want to use XPath with this document, you need to define the namespaces being used; otherwise the evaluation will fail.

The first way to handle namespaces is to create an `XPathNSResolver` object via the `createNSResolver()` method. This method accepts a single argument, which is a node in the document that contains the namespace definition. In the previous example, this node is the document element `<wrox:books>`, which has the `xmlns` attribute defining the namespace. This node can be passed into `createNSResolver()`, and the result can then be used in `evaluate()` as follows:

```
let nsresolver = xmldom.createNSResolver(xmldom.documentElement);

let result = xmldom.evaluate("wrox:book/wrox:author",
  xmldom.documentElement, nsresolver,
  XPathResult.ORDERED_NODE_SNAPSHOT_TYPE, null);

console.log(result.snapshotLength);
```

When the `nsresolver` object is passed into `evaluate()`, it ensures that the `wrox` prefix used in the XPath expression will be understood appropriately. Attempting to use this same expression without using an `XPathNSResolver` will result in an error.

The second way to deal with namespaces is by defining a function that accepts a namespace prefix and returns the associated URI, as in this example:

```
let nsresolver = function(prefix) {
  switch(prefix) {
```

```

    case "wrox": return "http://www.wrox.com/";
    // others here
  }
};

let result = xmldom.evaluate("count(wrox:book/wrox:author)",
    xmldom.documentElement, nsresolver, XPathResult.NUMBER_TYPE, null);

console.log(result.numberValue);

```

Defining a namespace-resolving function is helpful when you're not sure which node of a document contains the namespace definitions. As long as you know the prefixes and URIs, you can define a function to return this information and pass it in as the third argument to `evaluate()`.

XSLT SUPPORT IN BROWSERS

XSLT is a companion technology to XML that makes use of XPath to transform one document representation into another. Unlike XML and XPath, XSLT has no formal API associated with it and is not represented in the formal DOM at all. This left browser vendors to implement support in their own way. The first browser to add XSLT processing in JavaScript was Internet Explorer.

The XSLTProcessor Type

Mozilla implemented JavaScript support for XSLT in Firefox by creating a new type. The `XSLTProcessor` type allows developers to transform XML documents by using XSLT in a manner similar to the XSL processor in Internet Explorer. Since it was first implemented, all major browsers have copied the implementation, making `XSLTProcessor` into a de facto standard for JavaScript-enabled XSLT transformations.

As with the Internet Explorer implementation, the first step is to load two DOM documents, one with the XML and the other with the XSLT. After that, create a new `XSLTProcessor` and use the `importStylesheet()` method to assign the XSLT to it, as shown in this example:

```

let processor = new XSLTProcessor();
processor.importStylesheet(xsltdom);

```

The last step is to perform the transformation. This can be done in two different ways. If you want to return a complete DOM document as the result, call `transformToDocument()`. You can also get a document fragment object as the result by calling `transformToFragment()`. Generally speaking, the only reason to use `transformToFragment()` is if you intend to add the results to another DOM document.

When using `transformToDocument()`, just pass in the XML DOM and use the result as another completely different DOM. Here's an example:

```

let result = processor.transformToDocument(xmldom);
console.log(serializeXml(result));

```

The `transformToFragment()` method accepts two arguments: the XML DOM to transform and the document that should own the resulting fragment. This ensures that the new document fragment is

valid in the destination document. You can, therefore, create the fragment and add it to the page by passing in `document` as the second argument. Consider the following example:

```
let fragment = processor.transformToFragment(xmlDOM, document);
let div = document.getElementById("divResult");
div.appendChild(fragment);
```

Here, the processor creates a fragment owned by the `document` object. This enables the fragment to be added to a `<div>` element that exists in the page.

When the output format for an XSLT style sheet is either `"xml"` or `"html"`, creating a document or document fragment makes perfect sense. When the output format is `"text"`, however, you typically just want the text result of the transformation. Unfortunately, there is no method that returns text directly. Calling `transformToDocument()` when the output is `"text"` results in a full XML document being returned, but the contents of that document are different from browser to browser. Safari, for example, returns an entire HTML document, whereas Opera and Firefox return a one-element document with the output as the element's text.

The solution is to call `transformToFragment()`, which returns a document fragment that has a single child node containing the result text. You can, therefore, get the text by using the following code:

```
let fragment = processor.transformToFragment(xmlDOM, document);
let text = fragment.firstChild.nodeValue;
console.log(text);
```

This code works the same way for each of the supporting browsers and correctly returns just the text output from the transformation.

Using Parameters

The `XSLTProcessor` also allows you to set XSLT parameters using the `setParameter()` method, which accepts three arguments: a namespace URI, the parameter local name, and the value to set. Typically, the namespace URI is `null`, and the local name is simply the parameter's name. This method must be called prior to `transformToDocument()` or `transformToFragment()`. Here's an example:

```
let processor = new XSLTProcessor();
processor.importStylesheet(xslDOM);
processor.setParameter(null, "message", "Hello World!");
let result = processor.transformToDocument(xmlDOM);
```

Two other methods are related to parameters, `getParameter()` and `removeParameter()`; they are used to get the current value of a parameter and remove the parameter value, respectively. Each method takes the namespace URI (once again, typically `null`) and the local name of the parameter. For example:

```
let processor = new XSLTProcessor();
processor.importStylesheet(xslDOM);
processor.setParameter(null, "message", "Hello World!");

console.log(processor.getParameter(null, "message")); // outputs "Hello World!"
processor.removeParameter(null, "message");

let result = processor.transformToDocument(xmlDOM);
```

These methods aren't used often and are provided mostly for convenience.

Resetting the Processor

Each `XSLTProcessor` instance can be reused multiple times for multiple transformations with different XSLT style sheets. The `reset()` method removes all parameters and style sheets from the processor, allowing you to once again call `importStylesheet()` to load a different XSLT style sheet, as in this example:

```
let processor = new XSLTProcessor()
processor.importStylesheet(xsltdom);

// do some transformations

processor.reset();
processor.importStylesheet(xsltdom2);

// do more transformations
```

Reusing a single `XSLTProcessor` saves memory when using multiple style sheets to perform transformations.

SUMMARY

There is a great deal of support for XML and related technologies in JavaScript. Unfortunately, because of an early lack of specifications, there are several different implementations for common functionality. DOM Level 2 provides an API for creating empty XML documents but not for parsing or serialization. Browsers implemented two new types to deal with XML parsing and serialization as follows:

- The `DOMParser` type is a simple object that parses an XML string into a DOM document.
- The `XMLSerializer` type performs the opposite operation, serializing a DOM document into an XML string.

DOM Level 3 introduced a specification for an XPath API that has been implemented by all major browsers. The API enables JavaScript to run any XPath query against a DOM document and retrieve the result regardless of its data type.

The last related technology is XSLT, which has no public specification defining an API for its usage. Firefox created the `XSLTProcessor` type to handle transformations via JavaScript.

23

JSON

WHAT'S IN THIS CHAPTER?

- ▶ Understanding JSON syntax
- ▶ JSON parsing
- ▶ JSON serialization

WROX.COM DOWNLOADS FOR THIS CHAPTER

Please note that all the code examples for this chapter are available as a part of this chapter's code download on the book's website at www.wrox.com/go/projavascript4e on the Download Code tab.

There was a time when XML was the de facto standard for transmitting structured data over the internet. The first iteration of web services was largely XML-based, highlighting its target of server-to-server communication. XML was not, however, without its detractors. Some believed that the language was overly verbose and redundant. Several solutions arose to counter these problems, but the web had already started moving in a new direction.

Douglas Crockford first specified JavaScript Object Notation (JSON) as IETF RFC 4627 in 2006, even though it was in use as early as 2001. JSON is a strict subset of JavaScript, making use of several patterns found in JavaScript to represent structured data. Crockford put forth JSON as a better alternative to XML for accessing structured data in JavaScript because it could be passed directly to `eval()` and didn't require the creation of a DOM.

The most important thing to understand about JSON is that it is a data format, not a programming language. JSON is not a part of JavaScript even though they share syntax. JSON is also not solely used by JavaScript because it is a data format. There are parsers and serializers available in many programming languages.

SYNTAX

JSON syntax allows the representation of three types of values:

- **Simple values**—Strings, numbers, Booleans, and `null` can all be represented in JSON using the same syntax as JavaScript. The special value `undefined` is not supported.
- **Objects**—The first complex data type, objects represent ordered key-value pairs. Each value may be a primitive type or a complex type.
- **Arrays**—The second complex data type, arrays represent an ordered list of values that are accessible via a numeric index. The values may be of any type, including simple values, objects, and even other arrays.

There are no variables, functions, or object instances in JSON. JSON is all about representing structured data, and although it shares syntax with JavaScript, it should not be confused with JavaScript paradigms.

Simple Values

In its simplest form, JSON represents a small number of simple values. For example, the following is valid JSON:

```
5
```

This is JSON that represents the number 5. Likewise, the following is also valid JSON representing a string:

```
"Hello world!"
```

The big difference between JavaScript strings and JSON strings is that JSON strings must use double quotes to be valid (single quotes causes a syntax error).

Boolean values and `null` are valid exactly as they are as standalone JSON. In practice, however, JSON is most often used to represent more complex data structures of which simple values represent just part of the overall information.

Objects

Objects are represented using a slight modification of object literal notation. Object literals in JavaScript look like this:

```
let person = {  
  name: "Nicholas",  
  age: 29  
};
```

While this is the standard way that developers create object literals, it's the quoted property format that is used in JSON. The following is exactly the same as the previous example:

```
let object = {  
  "name": "Nicholas",  
  "age": 29  
};
```

The JSON representation of this same object is then:

```
{
  "name": "Nicholas",
  "age": 29
}
```

There are a couple of differences from the JavaScript example. First, there is no variable declaration (variables don't exist in JSON). Second, there is no trailing semicolon (not needed because this isn't a JavaScript statement). Once again, the quotes around the property name are required to be valid JSON. The value can be any simple or complex value, which allows you to embed objects within objects, such as:

```
{
  "name": "Nicholas",
  "age": 29,
  "school": {
    "name": "Merrimack College",
    "location": "North Andover, MA"
  }
}
```

This example embeds school information into the top-level object. Even though there are two properties called "name", they are in two different objects and so are allowed. You do want to avoid having two properties of the same name in the same object.

Unlike JavaScript, object property names in JSON must always be double-quoted. It's a common mistake to hand-code JSON without these double quotes or using single quotes.

Arrays

The second complex type in JSON is the array. Arrays are represented in JSON using array literal notation from JavaScript. For example, this is an array in JavaScript:

```
let values = [25, "hi", true];
```

You can represent this same array in JSON using a similar syntax:

```
[25, "hi", true]
```

Note once again the absence of a variable or a semicolon. Arrays and objects can be used together to represent more complex collections of data, such as:

```
[
  {
    "title": "Professional JavaScript",
    "authors": [
      "Nicholas C. Zakas",
      "Matt Frisbie"
    ],
    "edition": 4,
    "year": 2017
  },
  {
    "title": "Professional JavaScript",
```

```
    "authors": [
      "Nicholas C. Zakas"
    ],
    "edition": 3,
    "year": 2011
  },
  {
    "title": "Professional JavaScript",
    "authors": [
      "Nicholas C. Zakas"
    ],
    "edition": 2,
    "year": 2009
  },
  {
    "title": "Professional Ajax",
    "authors": [
      "Nicholas C. Zakas",
      "Jeremy McPeak",
      "Joe Fawcett"
    ],
    "edition": 2,
    "year": 2008
  },
  {
    "title": "Professional Ajax",
    "authors": [
      "Nicholas C. Zakas",
      "Jeremy McPeak",
      "Joe Fawcett"
    ],
    "edition": 1,
    "year": 2007
  },
  {
    "title": "Professional JavaScript",
    "authors": [
      "Nicholas C. Zakas"
    ],
    "edition": 1,
    "year": 2006
  }
]
```

This array contains a number of objects representing books. Each object has several keys, one of which is "authors", which is another array. Objects and arrays are typically top-level parts of a JSON data structure (even though this is not required) and can be used to create a large number of data structures.

PARSING AND SERIALIZATION

JSON rose to popularity not necessarily because it used familiar syntax. Rather, it became popular because the data could be parsed into a usable object in JavaScript. This stood in stark contrast to XML that was parsed into a DOM document, making extraction of data into a bit of a chore for

JavaScript developers. For example, the JSON code in the previous section contains a list of books, and you can easily get the title of the third book via:

```
books[2].title
```

This assumes that the data structure was stored in a variable named `books`. Compare this to a typical walk through of a DOM structure:

```
doc.getElementsByTagName("book")[2].getAttribute("title");
```

With all of the extra method calls, it's no wonder that JSON became incredibly popular with JavaScript developers. After that, JSON went on to become the de facto serialization standard for web services.

The JSON Object

Early JSON parsers did little more than use JavaScript's `eval()` function. Because JSON is a subset of JavaScript's syntax, `eval()` could parse, interpret, and return the data as JavaScript objects and arrays. ECMAScript 5 formalized JSON parsing under a native global called `JSON`. This object is supported in all major browsers. A shim for older browsers can be found at <https://github.com/douglascrockford/JSON-js>. It's important not to use `eval()` alone for evaluating JSON in older browsers because of the risk of executable code. The JSON shim is the best option for browsers without native JSON parsing.

The JSON object has two methods: `stringify()` and `parse()`. In simple usage, these methods serialize JavaScript objects into a JSON string and parse JSON into a native JavaScript value, respectively. For example:

```
let book = {
  title: "Professional JavaScript",
  authors: [
    "Nicholas C. Zakas",
    "Matt Frisbie"
  ],
  edition: 4,
  year: 2017
};
let jsonText = JSON.stringify(book);
```

This example serializes a JavaScript object into a JSON string using `JSON.stringify()` and stores it in `jsonText`. By default, `JSON.stringify()` outputs a JSON string without any extra white space or indentation, so the value stored in `jsonText` is as follows:

```
{"title":"Professional JavaScript","authors":["Nicholas C. Zakas","Matt Frisbie"],"edition":4,"year":2017}
```

When serializing a JavaScript object, all functions and prototype members are intentionally omitted from the result. Additionally, any property whose value is `undefined` is also skipped. You're left with just a representation of the instance properties that are one of the JSON data types.

A JSON string can be passed directly into `JSON.parse()` and it creates an appropriate JavaScript value. For example, you can create an object similar to the `book` object using this code:

```
let bookCopy = JSON.parse(jsonText);
```

Note that `book` and `bookCopy` are each separate objects without any relationship to one another even though they do share the same properties.

An error is thrown if the text passed into `JSON.parse()` is not valid JSON.

Serialization Options

The `JSON.stringify()` method actually accepts two arguments in addition to the object to serialize. These arguments allow you to specify alternate ways to serialize a JavaScript object. The first argument is a filter, which can be either an array or a function, and the second argument is an option for indenting the resulting JSON string. When used separately or together, this provides some very useful functionality for controlling JSON serialization.

Filtering Results

If the argument is an array, then `JSON.stringify()` will include only object properties that are listed in the array. Consider the following:

```
let book = {
  title: "Professional JavaScript",
  authors: [
    "Nicholas C. Zakas",
    "Matt Frisbie"
  ],
  edition: 4,
  year: 2017
};
let jsonText = JSON.stringify(book, ["title", "edition"]);
```

The second argument to `JSON.stringify()` is an array with two strings: `"title"` and `"edition"`. These correspond to properties in the object being serialized, so only those properties appear in the resulting JSON string:

```
{"title":"Professional JavaScript","edition":4}
```

When the second argument is a function, the behavior is slightly different. The provided function receives two arguments: the property key name and the property value. You can look at the key to determine what to do with the property. The key is always a string but might be an empty string if a value isn't part of a key-value pair.

In order to change the serialization of the object, return the value that should be included for that key. Keep in mind that returning `undefined` will result in the property being omitted from the result. Here's an example:

```
let book = {
  title: "Professional JavaScript",
  authors: [
    "Nicholas C. Zakas",
    "Matt Frisbie"
  ],
  edition: 4,
  year: 2017
};
```

```

let jsonText = JSON.stringify(book, (key, value) => {
  switch(key) {
    case "authors":
      return value.join(",");
    case "year":
      return 5000;
    case "edition":
      return undefined;
    default:
      return value;
  }
});

```

The function filters based on the key. The "authors" key is translated from an array to a string, the "year" key is set to 5000, and the "edition" key is removed altogether by returning `undefined`. It's important to provide a default behavior that returns the passed-in value so that all other values are passed through to the result. The first call to this function actually has `key` equal to an empty string and the `value` set to the `book` object. The resulting JSON string is:

```

{"title":"Professional JavaScript","authors":"Nicholas C. Zakas,Matt
Frisbie","year":5000}

```

Keep in mind that filters apply to all objects contained in the object to be serialized, so an array of multiple objects with these properties will result in every object including only the "title" and "edition" properties.

Firefox 3.5–3.6 had a bug in its implementation of `JSON.stringify()` when a function was used as the second argument. The function can act only as a filter: returning `undefined` means the property is skipped, while returning anything else causes the property to be included. This behavior was fixed in Firefox 4.

String Indentation

The third argument of `JSON.stringify()` controls indentation and white space. When this argument is a number, it represents the number of spaces to indent each level. For example, to indent each level by four spaces, use the following:

```

let book = {
  title: "Professional JavaScript",
  authors: [
    "Nicholas C. Zakas",
    "Matt Frisbie"
  ],
  edition: 4,
  year: 2017
};
let jsonText = JSON.stringify(book, null, 4);

```

The following is the string stored in `jsonText`:

```

{
  "title": "Professional JavaScript",
  "authors": [
    "Nicholas C. Zakas",

```



```
        "Matt Frisbie"
    ],
    "edition": 4,
    "year": 2017
}
```

You may have noticed that `JSON.stringify()` also inserts new lines into the JSON string for easier reading. This happens for all valid indentation argument values. (Indentation without new lines isn't very useful.) The maximum numeric indentation value is 10; passing in a value larger than 10 automatically sets the value to 10.

If the indentation argument is a string instead of a number, then the string is used as the indentation character for the JSON string instead of a space. Using a string, you can set the indentation character to be a tab or something completely arbitrary like two dashes:

```
let jsonText = JSON.stringify(book, null, "--");
```

The `jsonText` value then becomes:

```
{
--"title": "Professional JavaScript",
--"authors": [
----"Nicholas C. Zakas",
----"Matt Frisbie"
--],
--"edition": 4,
--"year": 2017
}
```

There is a ten-character limit on the indentation string to use. If a string longer than ten characters is used, then it is truncated to the first ten characters.

The toJSON() Method

Sometimes objects need custom JSON serialization above and beyond what `JSON.stringify()` can do. In those cases, you can add a `toJSON()` method to the object and have it return the proper JSON representation for itself. In fact, the native `Date` object has a `toJSON()` method that automatically converts JavaScript `Date` objects into an ISO 8601 date string (essentially, the same as calling `toISOString()` on the `Date` object).

A `toJSON()` method can be added to any object, for example:

```
let book = {
  title: "Professional JavaScript",
  authors: [
    "Nicholas C. Zakas",
    "Matt Frisbie"
  ],
  edition: 4,
  year: 2017,
  toJSON: function() {
    return this.title;
  }
};
let jsonText = JSON.stringify(book);
```

This code defines a `toJSON()` method on the `book` object that simply returns the title of the book. Similar to the `Date` object, this object is serialized to a simple string instead of an object. You can return any serialization value from `toJSON()`, and it will work appropriately. Returning `undefined` causes the value to become null if the object is embedded in another object or else is just `undefined` if the object is top-level. Note here that an arrow function is not used for the `toJSON()` method. This is primarily because the lexical scope of the arrow function will be the global scope, which is unhelpful in this example.

The `toJSON()` method can be used in addition to the filter function so it's important to understand the order in which the various parts of a serialization process take place. When an object is passed into `JSON.stringify()`, the following steps are taken:

1. Call the `toJSON()` method if it's available to retrieve the actual value. Use the default serialization otherwise.
2. If the second argument is provided, apply the filter. The value that is passed into a filter function will be the value returned from Step 1.
3. Each value from Step 2 is serialized appropriately.
4. If the third argument is provided, format appropriately.

It's important to understand this order when deciding whether to create a `toJSON()` method or to use a filter function or to do both.

Parsing Options

The `JSON.parse()` method also accepts an additional argument, which is a function that is called on each key-value pair. The function is called a *reviver* function to distinguish it from the *replacer* (filter) function that `JSON.stringify()` accepts, even though the format is exactly the same: the function receives two arguments, the key and the value, and needs to return a value.

If the *reviver* function returns `undefined`, then the key is removed from the result; if it returns any other value, that value is inserted into the result. A very common use of the *reviver* function is to turn date strings into `Date` objects. For example:

```
let book = {
  title: "Professional JavaScript",
  authors: [
    "Nicholas C. Zakas",
    "Matt Frisbie"
  ],
  edition: 4,
  year: 2017,
  releaseDate: new Date(2017, 11, 1)
};
let jsonText = JSON.stringify(book);
let bookCopy = JSON.parse(jsonText,
  (key, value) => key == "releaseDate" ? new Date(value) : value);
alert(bookCopy.releaseDate.getFullYear());
```

This code starts with the addition of a `releaseDate` property to the `book` object, which is a `Date`. The object is serialized to get a valid JSON string and then parsed back into an object, `bookCopy`. The `reviver` function looks for the `"releaseDate"` key and, when found, creates a new `Date` object based on that string. The resulting `bookCopy.releaseDate` property is then a `Date` object so the `getFullYear()` method can be called.

SUMMARY

JSON is a lightweight data format designed to easily represent complex data structures. The format uses a subset of JavaScript syntax to represent objects, arrays, strings, numbers, Booleans, and `null`. Even though XML can handle the same job, JSON is less verbose and has better support in JavaScript. What's more, the native `JSON` object is well supported across all browsers.

ECMAScript 5 defines a native `JSON` object that is used for serialization of objects into JSON format and for parsing JSON data into JavaScript objects. The `JSON.stringify()` and `JSON.parse()` methods are used for these two operations, respectively. Both methods have a number of options that allow you to change the default behavior to filter or otherwise modify the process.

24

Network Requests and Remote Resources

WHAT'S IN THIS CHAPTER?

- Using the XMLHttpRequest object
- Working with XMLHttpRequest events
- Cross-domain Ajax restrictions
- Fetch API
- Streams API

WROX.COM DOWNLOADS FOR THIS CHAPTER

Please note that all the code examples for this chapter are available as a part of this chapter's code download on the book's website at www.wrox.com/go/projavascript4e on the Download Code tab.

In 2005, Jesse James Garrett penned an online article titled “Ajax: A New Approach to Web Applications”. This article outlined a technique that he referred to as *Ajax*, short for *Asynchronous JavaScript+XML*. The technique consisted of making server requests for additional data without unloading the web page, resulting in a better user experience. Garrett explained how this technique could be used to change the traditional click-and-wait paradigm that the web had been stuck in since its inception.

The key technology pushing Ajax forward was the XMLHttpRequest (XHR) object, first invented by Microsoft and then duplicated by other browser vendors. Prior to the introduction of XHR, Ajax-style communication had to be accomplished through a number of hacks, mostly using hidden frames or iframes. XHR introduced a streamlined interface for making server requests and evaluating the responses. This allowed for asynchronous retrieval of additional

information from the server, meaning that a user click didn't have to refresh the page to retrieve more data. Instead, an XHR object could be used to retrieve the data and then the data could be inserted into the page using the DOM. And despite the mention of XML in the name, Ajax communication is format-agnostic; the technique is about retrieving data from the server without refreshing a page, not necessarily about XML.

The technique that Garrett referred to as Ajax had, in fact, been around for some time. Typically called *remote scripting* prior to Garrett's article, such browser-server communication has been possible since 1998 using different techniques. Early on, server requests could be made from JavaScript through an intermediary, such as a Java applet or Flash movie. The XHR object brought native browser communication capabilities to developers, reducing the amount of work necessary to achieve the result.

The XHR object's API is widely regarded as difficult to use, and, in the time since its introduction, the Fetch API has blossomed as a modernized replacement for XHR. Its support for promises and service workers has made it an incredibly powerful web development tool.

NOTE *This chapter includes full coverage of XMLHttpRequest, but in general it is an artifact of outdated JavaScript specifications and should only be used for legacy browser support—use fetch() whenever possible.*

THE XMLHttpRequest OBJECT

Internet Explorer 5 was the first browser to introduce the XHR object. It did so through the use of an ActiveX object included as part of the MSXML library. As such, three versions of the XHR object may be used in the browser: `MSXML2.XMLHttp`, `MSXML2.XMLHttp.3.0`, and `MSXML2.XMLHttp.6.0`.

All modern browsers support a native XHR object that can be created using the `XMLHttpRequest` constructor as follows:

```
let xhr = new XMLHttpRequest();
```

XHR Usage

To begin using an XHR object, you will first call the method `open()`, which accepts three arguments: the type of request to be sent ("get", "post", and so on), the URL for the request, and a Boolean value indicating if the request should be sent asynchronously. Here's an example:

```
xhr.open("get", "example.php", false);
```

This line opens a synchronous GET request for `example.php`. There are a couple of things to note about this code. First, the URL is relative to the page on which the code is called, although an absolute path can be given as well. Second, the call to `open()` does not actually send the request; it simply prepares a request to be sent.

NOTE *You can access only URLs that exist on the same origin, which means the same domain, using the same port, and with the same protocol. If the URL specifies any of these differently than the page making the request, a security error is thrown.*

To send the specified request, you must call the `send()` method as follows:

```
xhr.open("get", "example.txt", false);
xhr.send(null);
```

The `send()` method accepts a single argument, which is data to be sent as the body of the request. If no body data needs to be sent, you must pass in `null` because this argument is required for some browsers. Once `send()` is called, the request is dispatched to the server.

Because this request is synchronous, the JavaScript code will wait for the response to return before continuing execution. When a response is received, the XHR object properties are filled with data. The relevant properties are as follows:

- `responseText`—The text that was returned as the body of the response.
- `responseXML`—Contains an XML DOM document with the response data if the response has a content type of `"text/xml"` or `"application/xml"`.
- `status`—The HTTP status of the response.
- `statusText`—The description of the HTTP status.

When a response is received, the first step is to check the `status` property to ensure that the response was returned successfully. Generally, HTTP status codes in the 200s are considered successful and some content will be available in `responseText` and possibly in `responseXML` if the content type is correct. In addition, the status code of 304 indicates that a resource hasn't been modified and is being served from the browser's cache, which also means a response is available. To ensure that a proper response was received, you should check for all of these statuses, as shown here:

```
xhr.open("get", "example.txt", false);
xhr.send(null);

if ((xhr.status >= 200 && xhr.status < 300) || xhr.status == 304) {
    alert(xhr.responseText);
} else {
    alert("Request was unsuccessful: " + xhr.status);
}
```

This code displays either the content returned from the server or an error message, depending on the status code that was returned. It's recommended to always check the `status` property to determine the best course of action and to avoid using `statusText` for this purpose, because the latter has proven to be unreliable across browsers. The `responseText` property is always filled with the body of the response, regardless of the content type, whereas `responseXML` will be `null` for non-XML data.

Although it's possible to make synchronous requests such as this one, most of the time it's better to make asynchronous requests that allow JavaScript code execution to continue without waiting for the response. The XHR object has a `readyState` property that indicates what phase of the request/response cycle is currently active. The possible values are as follows:

- 0—Uninitialized. The `open()` method hasn't been called yet.
- 1—Open. The `open()` method has been called but `send()` has not been called.
- 2—Sent. The `send()` method has been called but no response has been received.
- 3—Receiving. Some response data has been retrieved.
- 4—Complete. All of the response data has been retrieved and is available.

Whenever the `readyState` changes from one value to another, the `readystatechange` event is fired. You can use this opportunity to check the value of `readyState`. Generally speaking, the only `readyState` of interest is 4, which indicates that all of the data is ready. The `onreadystatechange` event handler should be assigned prior to calling `open()` for cross-browser compatibility. Consider the following example:

```
let xhr = new XMLHttpRequest();
xhr.onreadystatechange = function() {
  if (xhr.readyState == 4) {
    if ((xhr.status >= 200 && xhr.status < 300) || xhr.status == 304) {
      alert(xhr.responseText);
    } else {
      alert("Request was unsuccessful: " + xhr.status);
    }
  }
};
xhr.open("get", "example.txt", true);
xhr.send(null);
```

Note that this code uses the DOM Level 0 style of attaching an event handler to the XHR object because not all browsers support the DOM Level 2 style of event attachment. Unlike other event handlers, no event object is passed into the `onreadystatechange` event handler. Instead you must use the XHR object itself to determine what to do next.

NOTE *This example uses the `xhr` object inside the `onreadystatechange` event handler instead of the `this` object because of scoping issues with the `onreadystatechange` event handler. Using `this` may cause the function to fail or cause an error, depending on the browser being used, so it's safer to use the actual XHR object-instance variable.*

You can cancel an asynchronous request before a response is received by calling the `abort()` method like this:

```
xhr.abort();
```

Calling this method makes the XHR object stop firing events and prevents access to any of the response-related properties on the object. Once a request has been aborted, the XHR object should be dereferenced. Because of memory issues, reusing an XHR object is not recommended.

HTTP Headers

Every HTTP request and response sends along with it a group of header information that may or may not be of interest to the developer. The XHR object exposes both types of headers—those on the request and those on the response—through several methods.

By default, the following headers are sent when an XHR request is sent:

- `Accept`—The content types that the browser can handle.
- `Accept-Charset`—The character sets that the browser can display.
- `Accept-Encoding`—The compression encodings handled by the browser.
- `Accept-Language`—The languages the browser is running in.
- `Connection`—The type of connection the browser is making with the server.
- `Cookie`—Any cookies set on the page.
- `Host`—The domain of the page making the request.
- `Referer`—The URI of the page making the request. Note that this header is spelled incorrectly in the HTTP specification and so must be spelled incorrectly for compatibility purposes. (The correct spelling of this word is “referrer.”)
- `User-Agent`—The browser’s user-agent string.

Although the exact request headers sent vary from browser to browser, these are the ones that are generally sent. You can set additional request headers by using the `setRequestHeader()` method. This method accepts two arguments: the name of the header and the value of the header. For request headers to be sent, `setRequestHeader()` must be called after `open()` but before `send()`, as in the following example:

```
let xhr = new XMLHttpRequest();
xhr.onreadystatechange = function() {
  if (xhr.readyState == 4) {
    if ((xhr.status >= 200 && xhr.status < 300) || xhr.status == 304) {
      alert(xhr.responseText);
    } else {
      alert("Request was unsuccessful: " + xhr.status);
    }
  }
};
xhr.open("get", "example.php", true);
xhr.setRequestHeader("MyHeader", "MyValue");
xhr.send(null);
```

The server can read these custom request headers to determine an appropriate course of action. It's advisable to always use custom header names rather than those the browser normally sends because using the default ones may affect the server response. Some browsers will allow overwriting default headers, but others will not.

You can retrieve the response headers from an XHR object by using the `getResponseHeader()` method and passing in the name of the header to retrieve. It's also possible to retrieve all headers as a long string by using the `getAllResponseHeaders()` method. Here's an example of both methods:

```
let myHeader = xhr.getResponseHeader("MyHeader");
let allHeaders = xhr.getAllResponseHeaders();
```

Headers can be used to pass additional, structured data from the server to the browser. The `getAllResponseHeaders()` method typically returns something along the lines of the following:

```
Date: Sun, 14 Nov 2004 18:04:03 GMT
Server: Apache/1.3.29 (Unix)
Vary: Accept
X-Powered-By: PHP/4.3.8
Connection: close
Content-Type: text/html; charset=iso-8859-1
```

This output allows you to parse the response headers to find all of the header names that were sent rather than check for the existence of each one individually.

GET Requests

The most common type of request to execute is a GET, which is typically made when the server is being queried for some sort of information. If necessary, query-string arguments can be appended to the end of the URL to pass information to the server. For XHR, this query string must be present and encoded correctly on the URL that is passed into the `open()` method.

One of the most frequent errors made with GET requests is to have an improperly formatted query string. Each query-string name and value must be encoded using `encodeURIComponent()` before being attached to the URL, and all of the name-value pairs must be separated by an ampersand, as in this example:

```
xhr.open("get", "example.php?name1=value1&name2=value2", true);
```

The following function helps to add query-string arguments to the end of an existing URL:

```
function addURLParam(url, name, value) {
    url += (url.indexOf("?") == -1 ? "?" : "&");
    url += encodeURIComponent(name) + "=" + encodeURIComponent(value);
    return url;
}
```

The `addURLParam()` function takes three arguments: the URL to add the parameters to, the parameter name, and the parameter value. First, the function checks to see if the URL already contains a question mark (to determine if other parameters already exist). If it doesn't, then the function appends a question mark; otherwise it adds an ampersand. Next, the name and value are encoded and appended to the end of the URL. The last step is to return the updated URL.

This function can be used to build up a URL for a request, as shown in the following example:

```
let url = "example.php";
```

```
// add the arguments
url = addURLParam(url, "name", "Nicholas");
url = addURLParam(url, "book", "Professional JavaScript");

// initiate request
xhr.open("get", url, false);
```

Using the `addURLParam()` function here ensures that the query string is properly formed for use with the XHR object.

POST Requests

The second most frequent type of request is POST, which is typically used to send data to the server that should save data. Each POST request is expected to have data submitted as the body of the request, whereas GET requests traditionally do not. The body of a POST request can contain a very large amount of data, and that data can be in any format. You can initiate a POST request by specifying `post` as the first argument to the `open()` method. For example:

```
xhr.open("post", "example.php", true);
```

The second part is to pass some data to the `send()` method. Since XHR was originally designed to work primarily with XML, you can pass in an XML DOM document that will be serialized and submitted as the request body. You can also pass in any string to send to the server.

By default, a POST request does not appear the same to the server as a web-form submission. Server logic will need to read the raw post data to retrieve your data. You can, however, mimic a form submission using XHR. The first step is to set the `Content-Type` header to `application/x-www-form-urlencoded`, which is the content type set when a form is submitted. The second step is to create a string in the appropriate format. Post data is sent in the same format as a query string. If a form already on the page should be serialized and sent to the server via XHR, you can use the `serialize()` function from Chapter 14 to create the string, as shown here:

```
function submitData() {
  let xhr = new XMLHttpRequest();
  xhr.onreadystatechange = function() {
    if (xhr.readyState == 4) {
      if ((xhr.status >= 200 && xhr.status < 300) || xhr.status == 304) {
        alert(xhr.responseText);
      } else {
        alert("Request was unsuccessful: " + xhr.status);
      }
    }
  };
}

xhr.open("post", "postexample.php", true);
xhr.setRequestHeader("Content-Type", "application/x-www-form-urlencoded");
let form = document.getElementById("user-info");
xhr.send(serialize(form));
}
```

In this function, form data from a form with the ID `user-info` is serialized and sent to the server. The PHP file `postexample.php` can then retrieve the posted data via `$_POST`. Consider this example:

```
<?php
header("Content-Type: text/plain");
echo <<<EOF
```

```
Name: {$_POST['user-name']}
Email: {$_POST['user-email']}
EOF;
?>
```

Without including the `Content-Type` header, the data will not appear in the `$_POST` superglobal—you'd need to use `$HTTP_RAW_POST_DATA` to access it.

NOTE *POST requests have more overhead associated with them than do GET requests. In terms of performance, GET requests can be up to two times faster than POST requests sending the same amount of data.*

XMLHttpRequest LEVEL 2

The popularity of the `XHR` object as a de facto standard led to the creation of official specifications from the W3C to govern its behavior. `XMLHttpRequest Level 1` simply defined the already existing implementation details of the `XHR` object. `XMLHttpRequest Level 2` went on to evolve the `XHR` object further. Not all browsers have implemented all parts of the Level 2 specification, but all browsers have implemented some of the functionality.

The FormData Type

The serialization of form data is frequently needed in modern web applications, and so the `XMLHttpRequest Level 2` specification introduces the `FormData` type. The `FormData` type makes it easy to both serialize existing forms and create data in the same format as a form for easy transmission via `XHR`. The following creates a `FormData` object and populates it with some data:

```
let data = new FormData();
data.append("name", "Nicholas");
```

The `append()` method accepts two arguments, a key and a value, essentially the name of a form field and the value that the field contains. You can add as many of these pairs as you would like. It's also possible to prepopulate the key-value pairs with data that exists in a form element by passing in the form element to the `FormData` constructor:

```
let data = new FormData(document.forms[0]);
```

Once you have an instance of `FormData`, it can be passed directly into the `XHR send()` method, as in this example:

```
let xhr = new XMLHttpRequest();
xhr.onreadystatechange = function() {
  if (xhr.readyState == 4) {
    if ((xhr.status >= 200 && xhr.status < 300) || xhr.status == 304) {
      alert(xhr.responseText);
    } else {
      alert("Request was unsuccessful: " + xhr.status);
    }
  }
}
```

```

};
xhr.open("post", "postexample.php", true);
let form = document.getElementById("user-info");
xhr.send(new FormData(form));

```

One of the conveniences of the `FormData` type is that you don't need to explicitly set any request headers on the XHR object. The XHR object recognizes the passed-in data type as an instance of `FormData` and configures the headers appropriately.

Timeouts

In Internet Explorer 8, the XHR object was augmented to include a `timeout` property that indicates the number of milliseconds the request should wait for a response before aborting. All browsers have since adopted this property into their XHR implementations. When the `timeout` property is set to a number and the response is not received within that number of milliseconds, a `timeout` event is fired and the `ontimeout` event handler is called. This functionality was later added into the XMLHttpRequest Level 2 specification. Here's an example:

```

let xhr = new XMLHttpRequest();
xhr.onreadystatechange = function() {
  if (xhr.readyState == 4) {
    try {
      if ((xhr.status >= 200 && xhr.status < 300) || xhr.status == 304) {
        alert(xhr.responseText);
      } else {
        alert("Request was unsuccessful: " + xhr.status);
      }
    } catch (ex) {
      // assume handled by ontimeout
    }
  }
};

xhr.open("get", "timeout.php", true);
xhr.timeout = 1000; // set timeout for 1 second
xhr.ontimeout = function() {
  alert("Request did not return in a second.");
};
xhr.send(null);

```

This example illustrates the use of the `timeout` property. Setting it equal to 1,000 milliseconds means that if the request doesn't return in 1 second or less, the request is aborted. When that happens, the `ontimeout` event handler is called. The `readyState` is still changed to 4, which means the `onreadystatechange` event handler is called. However, an error occurs if you try to access the `status` property after a timeout has occurred. To protect against this, encapsulate the code that checks the `status` property in a `try-catch` statement.

The `overrideMimeType()` Method

Firefox first introduced `overrideMimeType()` as a way to override the MIME type of an XHR response. This was later added to XMLHttpRequest Level 2. Because the returned MIME type for a response determines how the response is handled by the XHR object, having a way to override the type returned by the server is a useful addition.

Consider the case where the server sends a MIME type of `text/plain` that actually contains XML. This would result in the `responseXML` property being `null` even though the data is actually XML. By calling `overrideMimeType()`, you can ensure the response is treated as XML instead of plain text:

```
let xhr = new XMLHttpRequest();
xhr.open("get", "text.php", true);
xhr.overrideMimeType("text/xml");
xhr.send(null);
```

This example forces the XHR object to treat the response as XML instead of plain text. The call to `overrideMimeType()` must happen before the call to `send()` in order to correctly override the response MIME type.

PROGRESS EVENTS

The Progress Events specification is a W3C Working Draft defining events for client-server communication. These events were first targeted at XHR explicitly but have now also made their way into other similar APIs. There are six progress events:

- `loadstart`—Fires when the first byte of the response has been received.
- `progress`—Fires repeatedly as a response is being received.
- `error`—Fires when there was an error attempting the request.
- `abort`—Fires when the connection was terminated by calling `abort()`.
- `load`—Fires when the response has been fully received.
- `loadend`—Fires when the communication is complete and after firing `error`, `abort`, or `load`.

Each request begins with the `loadstart` event being fired; followed by one or more `progress` events; then one of `error`, `abort`, or `load`; finally ending with `loadend`.

Most of these events are straightforward, but there are two that have some subtleties to be aware of.

The load Event

When Firefox first implemented a version of the XHR object, it sought to simplify the interaction model. To that end, the `load` event was introduced as a replacement for the `readystatechange` event. The `load` event fires as soon as the response has been completely received, eliminating the need to check the `readyState` property. The `onload` event handler receives an `event` object whose `target` property is set to the XHR object instance, and all of the XHR object properties and methods are available from within. However, not all browsers properly implement the `event` object for this event, which necessitates the use of the XHR object variable itself, as shown in the following example:

```
let xhr = new XMLHttpRequest();
xhr.onload = function() {
  if ((xhr.status >= 200 && xhr.status < 300) || xhr.status == 304) {
    alert(xhr.responseText);
  } else {
```

```

        alert("Request was unsuccessful: " + xhr.status);
    }
};
xhr.open("get", "altevents.php", true);
xhr.send(null);

```

As long as a response is received from the server, regardless of the status, the `load` event will fire. This means you must check the `status` property to determine if the appropriate data is available. The `load` event is supported by Firefox, Opera, Chrome, and Safari.

The progress Event

Another XHR innovation from Mozilla is the `progress` event, which fires periodically as the browser receives new data. The `onprogress` event listener receives an event object whose `target` is the XHR object and contains three additional properties: `lengthComputable`, a Boolean indicating if progress information is available; `position`, which is the number of bytes that have already been received; and `totalSize`, which is the total number of expected bytes as defined by the `Content-Length` response header. With that information, you can provide a progress indicator to the user. The following code includes an example of how this is done:

```

let xhr = new XMLHttpRequest();
xhr.onload = function(event) {
    if ((xhr.status >= 200 && xhr.status < 300) ||
        xhr.status == 304) {
        alert(xhr.responseText);
    } else {
        alert("Request was unsuccessful: " + xhr.status);
    }
};
xhr.onprogress = function(event) {
    let divStatus = document.getElementById("status");
    if (event.lengthComputable) {
        divStatus.innerHTML = "Received " + event.position + " of " +
            event.totalSize +
            " bytes";
    }
};

xhr.open("get", "altevents.php", true);
xhr.send(null);

```

For proper execution, the `onprogress` event handler must be attached prior to calling `open()`. In the preceding example, an HTML element is filled with status information every time the `progress` event is fired. Assuming that the response has a `Content-Length` header, you can also use this information to calculate the percentage of the response that has already been received.

CROSS-ORIGIN RESOURCE SHARING

One of the major limitations of Ajax communication via XHR is the cross-origin security policy. By default, XHR objects can access resources only on the domain from which the containing web page originates. This security feature prevents some malicious behavior. However, the need for legitimate cross-origin access was great enough for solutions to begin appearing in browsers.

Cross-Origin Resource Sharing (CORS) defines how the browser and server must communicate when accessing sources across origins. The basic idea behind CORS is to use custom HTTP headers to allow both the browser and the server to know enough about each other to determine if the request or response should succeed or fail.

For a simple request, one that uses either GET or POST with no custom headers and whose body is text/plain, the request is sent with an extra header called `Origin`. The `Origin` header contains the origin (protocol, domain name, and port) of the requesting page so that the server can easily determine whether or not it should serve a response. An example `Origin` header might look like this:

```
Origin: http://www.nczonline.net
```

If the server decides that the request should be allowed, it sends an `Access-Control-Allow-Origin` header echoing back the same origin that was sent or `*` if it's a public resource. For example:

```
Access-Control-Allow-Origin: http://www.nczonline.net
```

If this header is missing, or the origins don't match, then the browser disallows the request. If all is well, then the browser processes the request. Note that neither the requests nor the responses include cookie information.

Modern browsers support CORS natively through the `XMLHttpRequest` object. When attempting to open a resource on a different origin, this behavior automatically gets triggered without any extra code. To make a request to a resource on another domain, the standard XHR object is used with an absolute URL specified in `open()`, such as this:

```
let xhr = new XMLHttpRequest();
xhr.onreadystatechange = function() {
  if (xhr.readyState == 4) {
    if ((xhr.status >= 200 && xhr.status < 300) || xhr.status == 304) {
      alert(xhr.responseText);
    } else {
      alert("Request was unsuccessful: " + xhr.status);
    }
  }
};
xhr.open("get", "http://www.somewhere-else.com/page/", true);
xhr.send(null);
```

The cross-domain XHR object allows access to the `status` and `statusText` properties and allows synchronous requests. There are some additional limitations on a cross-domain XHR object that are necessary for security purposes. They are as follows:

- Custom headers cannot be set using `setRequestHeader()`.
- Cookies are neither sent nor received.
- The `getAllResponseHeaders()` method always returns an empty string.

Because the same interface is used for both same- and cross-domain requests, it's best to always use a relative URL when accessing a local resource, and an absolute URL when accessing a remote resource. This disambiguates the use case and can prevent problems such as limiting access to header and/or cookie information for local resources.

Preflighted Requests

CORS allows the use of custom headers, methods other than GET or POST, and different body content types through a transparent mechanism of server verification called *preflighted requests*. When you try to make a request with one of the advanced options, a “preflight” request is made to the server. This request uses the OPTIONS method and sends the following headers:

- `Origin`—Same as in simple requests.
- `Access-Control-Request-Method`—The method that the request wants to use.
- `Access-Control-Request-Headers`—(Optional) A comma-separated list of the custom headers being used.

Here’s an example assuming a POST request with a custom header called NCZ:

```
Origin: http://www.nczonline.net
Access-Control-Request-Method: POST
Access-Control-Request-Headers: NCZ
```

During this request, the server can determine whether or not it will allow requests of this type. The server communicates this to the browser by sending the following headers in the response:

- `Access-Control-Allow-Origin`—Same as in simple requests.
- `Access-Control-Allow-Methods`—A comma-separated list of allowed methods.
- `Access-Control-Allow-Headers`—A comma-separated list of headers that the server will allow.
- `Access-Control-Max-Age`—The amount of time in seconds that this preflight request should be cached for.

For example:

```
Access-Control-Allow-Origin: http://www.nczonline.net
Access-Control-Allow-Methods: POST, GET
Access-Control-Allow-Headers: NCZ
Access-Control-Max-Age: 1728000
```

Once a preflight request has been made, the result is cached for the period of time specified in the response; you’ll only incur the cost of an extra HTTP request the first time a request of this type is made.

Credentialed Requests

By default, cross-origin requests do not provide credentials (cookies, HTTP authentication, and client-side SSL certificates). You can specify that a request should send credentials by setting the `withCredentials` property to `true`. If the server allows credentialed requests, then it responds with the following HTTP header:

```
Access-Control-Allow-Credentials: true
```

If a credentialed request is sent and this header is not sent as part of the response, then the browser doesn’t pass the response to JavaScript (`responseText` is an empty string, `status` is 0, and

`onerror()` is invoked). Note that the server can also send this HTTP header as part of the preflight response to indicate that the origin is allowed to send credentialed requests.

ALTERNATE CROSS-DOMAIN TECHNIQUES

Before CORS came about, achieving cross-domain Ajax communication was a bit trickier. Developers came to rely on parts of the DOM that could perform cross-domain requests as a simple way to make certain types of requests without using the XHR object. Despite the ubiquity of CORS, these techniques are still popular because they don't involve changes on the server.

Image Pings

One of the first techniques for cross-domain communication was through the use of the `` tag. Images can be loaded cross-domain by any page without worrying about restrictions. This is the main way that online advertisements track views. You can also dynamically create images and use their `onload` and `onerror` event handlers to tell you when the response has been received.

Dynamically creating images is often used for *image pings*. Image pings are simple, cross-domain, one-way communication with the server. The data is sent via query-string arguments and the response can be anything, though typically it's a pixel image or a 204 response. The browser can't get any specific data back from an image ping but it can tell when the response has been received by listening for the `load` and `error` events. Here's a simple example:

```
let img = new Image();
img.onload = img.onerror = function() {
  alert("Done!");
};
img.src = "http://www.example.com/test?name=Nicholas";
```

This example creates a new instance of `Image` and then assigns both the `onload` and the `onerror` event handlers to the same function. This ensures that regardless of the response, you'll be notified when the request has completed. The request begins when the `src` property is set and this example is sending along a `name` parameter.

Image pings are frequently used for tracking user clicks on a page or dynamic ad impressions. The two main downsides to image pings are that you can only send GET requests and you cannot access the response text from the server. This is why image pings are best used for one-way communication between the browser and the server.

JSONP

JSONP is short for "JSON with padding" and is a special variant of JSON that has become popular for web services. JSONP looks just like JSON except that the data is wrapped within what looks like a function call. For example:

```
callback({ "name": "Nicholas" });
```

The JSONP format is made up of two parts: the callback and the data. The callback is the function that should be called on the page when the response has been received. Typically the name of the

callback is specified as part of the request. The data is simply the JSON data to pass to the function. A typical JSONP request looks like this:

```
http://freegeoip.net/json/?callback=handleResponse
```

This URL is for a JSONP geolocation service. It's quite common to have the callback parameter specified as a query string argument for JSONP services, and in this case, I've specified the callback function name to be `handleResponse()`.

JSONP is used through dynamic `<script>` elements assigning the `src` to a cross-domain URL. The `<script>` element, similar to ``, is capable of loading resources from other domains without restriction. Because JSONP is valid JavaScript, the JSONP response gets pulled into the page and executed immediately upon completion. Here's an example:

```
function handleResponse(response) {
  console.log(`
    You're at IP address ${response.ip}, which is in
    ${response.city}, ${response.region_name}`);
}
let script = document.createElement("script");
script.src = "http://freegeoip.net/json/?callback=handleResponse";
document.body.insertBefore(script, document.body.firstChild);
```

This example displays your IP address and location information from the geolocation service.

JSONP is very popular for web developers because of its simplicity and ease of use. Its advantage over image pings is that you can access the response text directly, allowing bidirectional communication between browser and server. There are, however, a couple of downsides to using JSONP.

First, you're pulling executable code into your page from another domain. If that domain isn't trusted, it could very easily swap the response for something more malicious, and you would have no recourse aside from removing the JSONP call altogether. When using a web service that you don't operate, make sure that it comes from a trusted source.

The second downside is that there is no easy way to determine that a JSONP request has failed. Although HTML5 has specified an `onerror` event handler for `<script>` elements, it hasn't yet been implemented by any browser. Developers frequently used timers to see if a response has or has not been received within a set amount of time, but even this is tricky because not every user has the same connection speed and bandwidth.

THE FETCH API

The Fetch API can perform all the same tasks as an `XMLHttpRequest` object, but is much easier to use, has a more modern interface, and is able to be used by modern web tools like web workers. Whereas the `XMLHttpRequest` is optionally asynchronous, all requests dispatched by the Fetch API are strictly asynchronous. The Fetch API is a WHATWG living standard specification, which can be found at <https://fetch.spec.whatwg.org/>. The specification puts it best: “*The Fetch standard defines requests, responses, and the process that binds them: fetching.*”

The Fetch API itself is a superior tool for requesting resources in JavaScript, but the API is also relevant in the domain of service workers in that it provides an interface for intercepting, redirecting, and altering requests made via `fetch()`.

Basic API Utilization

The `fetch()` method is available in any global scope, both in the primary page execution, modules, and inside workers. Invoking it will instruct the browser to send a request to a provided URL.

Dispatching a Request

The `fetch()` method has only a single required parameter `input`, which most of the time will be the URL of the resource you wish to fetch. This method returns a promise:

```
let r = fetch('/bar');
console.log(r); // Promise <pending>
```

The interpretation of this URL (relative paths, absolute paths, and so on) is performed identically to that of an XHR request.

When the request completes and the resource is available, the promise will resolve into a `Response` object, which is used as the API wrapper for whatever resource was fetched. This object exposes a number of properties and methods to inspect the response and convert the payload into a useful form, as shown here:

```
fetch('bar.txt')
  .then((response) => {
    console.log(response);
  });

// Response { type: "basic", url: ... }
```

Reading a Response

The simplest way to read the contents of a response is in the raw text format, which is accessed using the `text()` method. This method returns a promise that resolves with the full contents of the fetched resource:

```
fetch('bar.txt')
  .then((response) => {
    response.text().then((data) => {
      console.log(data);
    });
  });

// Contents of bar.txt!
```

This promise structure is commonly flattened:

```
fetch('bar.txt')
  .then((response) => response.text())
  .then((data) => console.log(data));

// Contents of bar.txt!
```

Handling Status Codes and Request Failures

The Fetch API allows you to inspect the `Response` object’s status code and status text, accessible via the `status` and `statusText` properties, respectively. Successfully fetching the resource will typically yield a response code of 200, as shown in this example:

```
fetch('/bar')
  .then((response) => {
    console.log(response.status);      // 200
    console.log(response.statusText);  // OK
  });
```

Requesting a resource that doesn’t exist will typically yield a response code of 404:

```
fetch('/does-not-exist')
  .then((response) => {
    console.log(response.status);      // 404
    console.log(response.statusText);  // Not Found
  });
```

Requesting a resource URL that throws a server error will typically yield a response code of 500:

```
fetch('/throw-server-error')
  .then((response) => {
    console.log(response.status);      // 500
    console.log(response.statusText);  // Internal Server Error
  });
```

The behavior of `fetch()` with respect to redirects can be explicitly set (as detailed later in this chapter), but the default behavior is to follow a redirect and return a response that does not have a response code of 300–399. When a `fetch` is followed, the `redirected` property is set to `true` on the response object but will still feature a response code of 200:

```
fetch('/permanent-redirect')
  .then((response) => {
    // Default behavior is to follow the redirects until reaching a terminal URL.
    // This example would incur at least two round trip network requests:
    // <origin url>/permanent-redirect -> <redirect url>
    console.log(response.status);      // 200
    console.log(response.statusText);  // OK
    console.log(response.redirected);  // true
  });
```

In all of these examples, notice that the *resolved* handler of the `fetch` promise is being executed—even when the request could be considered a failure, such as a 500 status. If the server sends a response of any kind, the `fetch()` promise will resolve. This behavior should make sense: the system-level network protocol has completed a successful round-trip message transmission. What qualifies as a “successful” request should be defined in how that response is handled.

Commonly, a response in the 200s is considered successful, and anything else is considered unsuccessful. To differentiate between these, the `Response` object’s `ok` property identifies when the response code is between 200–299.

```
fetch('/bar')
  .then((response) => {
    console.log(response.status);      // 200
    console.log(response.ok);         // true
  });
```

```

});
fetch('/does-not-exist')
  .then((response) => {
    console.log(response.status); // 404
    console.log(response.ok);    // false
  });

```

A true `fetch()` failure—such as a browser timeout where there is no server response—will reject:

```

fetch('/hangs-forever')
  .then((response) => {
    console.log(response);
  }, (err) => {
    console.log(err);
  });

// (after browser timeout duration)
// TypeError: "NetworkError when attempting to fetch resource."

```

The request promise rejects for reasons such as for reasons such as CORS violations, a lack of connection to a network, HTTPS violations, and other browser/network policy violations.

You can inspect the full URL used by `fetch()` when dispatching the request with the `url` property:

```

// Requests made from foo.com/bar/baz
console.log(window.location.href); // https://foo.com/bar/baz

fetch('qux').then((response) => console.log(response.url));
// https://foo.com/bar/qux

fetch('/qux').then((response) => console.log(response.url));
// https://foo.com/qux

fetch('//qux.com').then((response) => console.log(response.url));
// https://qux.com

fetch('https://qux.com').then((response) => console.log(response.url));
// https://qux.com

```

Custom Fetch Options

When used with only a URL, `fetch()` will dispatch a GET request with a minimal set of request headers. To configure how a request is dispatched, an `init` object can be passed as the optional second argument to `fetch()`. The `init` object should be populated with any number of the keys and corresponding values in the table that follows.

KEY	VALUE
<code>body</code>	Used to specify the body field for requests that make use of a body. Must be any <code>Blob</code> , <code>BufferSource</code> , <code>FormData</code> , <code>URLSearchParams</code> , <code>ReadableStream</code> , or <code>string</code> instance.

KEY	VALUE
cache	<p>Used to control how the browser will interact with the HTTP cache when performing the fetch. For cached redirects to be followed, the request must have <code>follow</code> as its <code>redirect</code> value and must also comply with same-origin restrictions. Must be one of the following string values:</p> <p><code>default</code></p> <ul style="list-style-type: none"> ➤ A fresh cache hit is returned from <code>fetch()</code>. No request is sent. ➤ A stale cache hit will send a conditional request. If the response has changed, the cached value is updated. The cached value is then returned from <code>fetch()</code>. ➤ A cache miss will send a request and the response is cached. The response is returned from <code>fetch()</code>. <p><code>no-store</code></p> <ul style="list-style-type: none"> ➤ The browser sends a request without checking the cache. ➤ The response is not cached and is returned from <code>fetch()</code>. <p><code>reload</code></p> <ul style="list-style-type: none"> ➤ The browser sends a request without checking the cache. ➤ The response is cached and is returned from <code>fetch()</code>. <p><code>no-cache</code></p> <ul style="list-style-type: none"> ➤ Both a fresh or stale cache hit will send a conditional request. If the response has changed, the cached value is updated. The cached value is then returned from <code>fetch()</code>. ➤ A cache miss will send a request and the response is cached. The response is returned from <code>fetch()</code>. <p><code>force-cache</code></p> <ul style="list-style-type: none"> ➤ Both a fresh or stale cache hit will be returned from <code>fetch()</code>. No request is sent. ➤ A cache miss will send a request and the response is cached. The response is returned from <code>fetch()</code>. <p><code>only-if-cached</code></p> <ul style="list-style-type: none"> ➤ Can only be used if the request mode is <code>same-origin</code>. ➤ Both a fresh or stale cache hit will be returned from <code>fetch()</code>. No request is sent. ➤ A cache miss will return a response with a status of 504 (Gateway timeout). <p>Defaults to <code>default</code>.</p>

KEY	VALUE
<code>credentials</code>	<p>Used to specify if and how cookies should be included with the outgoing request. This is similar to the <code>XMLHttpRequest</code> <code>withCredentials</code> flag.</p> <p>Must be one of the following <code>string</code> values:</p> <ul style="list-style-type: none"> ➤ <code>omit</code>: No cookies are sent. ➤ <code>same-origin</code>: Only send cookies when the request URL origin matches the origin of the script executing the <code>fetch</code>. ➤ <code>include</code>: Cookies are included with both <code>same-origin</code> and <code>cross-origin</code> requests. <p>Can also be a <code>FederatedCredential</code> instance or a <code>PasswordCredential</code> instance in browsers that support the Credential Management API.</p> <p>Defaults to <code>same-origin</code>.</p>
<code>headers</code>	<p>Used to specify headers for a request.</p> <p>Must be either a <code>Headers</code> object instance or regular object instance containing header key-value <code>string</code> pairs.</p> <p>Defaults to a <code>Headers</code> object with no key-value pairs. This does not mean the request will be sent with no headers; the browser may still add headers when the request is formally dispatched. This disparity will be invisible to JavaScript but can still be observed in the browser's network inspector.</p>
<code>integrity</code>	<p>Used to enforce subresource integrity.</p> <p>Must be a <code>string</code> containing the subresource integrity identifier.</p> <p>Defaults to an empty <code>string</code>.</p>
<code>keepalive</code>	<p>Used to direct the browser to allow the request to exist beyond the page's lifetime. This is useful for reporting events or analytics metrics to a server when a page unload might occur soon after a <code>fetch</code> is dispatched. <code>Fetch</code> with the <code>keepalive</code> flag can be used as a substitute for <code>Navigator.sendBeacon()</code>.</p> <p>Must be a <code>boolean</code>.</p> <p>Defaults to <code>false</code>.</p>
<code>method</code>	<p>Used to specify the HTTP method of a request.</p> <p>Will almost always be one of the following <code>string</code> values:</p> <ul style="list-style-type: none"> GET POST PUT PATCH DELETE HEAD OPTIONS

KEY	VALUE
	<p>CONNECT</p> <p>TRACE</p> <p>Defaults to <code>GET</code>.</p>
<code>mode</code>	<p>Used to specify the mode for the request. The mode determines if a response from a cross-origin request is valid and how much of the response is readable by the client. Requests that violate the specified mode will throw an error.</p> <p>Must be one of the following <code>string</code> values:</p> <ul style="list-style-type: none"> ➤ <code>cors</code>: Cross-origin requests that comply with the CORS protocol are allowed. The response will be a “CORS-filtered response,” meaning the headers accessible in the response are filtered by a browser-enforced whitelist. ➤ <code>no-cors</code>: Cross-origin requests that do not require a preflight request (HEAD, GET, and POST with only CORS-safelisted request headers) are allowed. The response type will be <code>opaque</code>, meaning the content of the response cannot be read. ➤ <code>same-origin</code>: No cross-origin requests of any kind are allowed. ➤ <code>navigate</code>: Intended for supporting HTML navigation, created only when navigating between documents. You will likely never need to use this mode. <p>When a <code>Request</code> instance is manually created via its constructor, defaults to <code>cors</code>. Otherwise, defaults to <code>no-cors</code>.</p>
<code>redirect</code>	<p>Used to specify how redirected responses (defined as a response status code of 301, 302, 303, 307, or 308) should be handled.</p> <p>Must be one of the following <code>string</code> values:</p> <ul style="list-style-type: none"> ➤ <code>follow</code>: Requests that redirect will be followed and the eventual URL that has a non-redirected response will be returned as the final response. ➤ <code>error</code>: Requests that redirect will throw an error. ➤ <code>manual</code>: Requests that redirect will not follow the redirect and instead return a response with type <code>opaqueredirect</code> while still exposing the intended redirect URL. This allows the redirect to be followed manually. <p>Defaults to <code>follow</code>.</p>
<code>referrer</code>	<p>Used to specify what should be sent as the HTTP <code>Referer</code> header.</p> <p>Must be one of the following <code>string</code> values:</p> <ul style="list-style-type: none"> ➤ <code>no-referrer</code>: Send <code>no-referrer</code> as the HTTP referrer value. ➤ <code>client/about:client</code>: Send the current URL or <code>no-referrer</code> (determined by the referrer policy) as the actual HTTP referrer value. ➤ <code><URL></code>: Spoof the URL sent as the HTTP <code>Referer</code>. The origin of the spoofed URL must match the origin of the executing script. <p>Defaults to <code>client/about:client</code>.</p>

KEY	VALUE
referrer-Policy	<p>Used to specify the HTTP <code>Referer</code> header.</p> <p>Must be one of the following string values:</p> <p><code>no-referrer</code></p> <ul style="list-style-type: none"> ➤ The <code>Referer</code> header is omitted entirely from the request. <p><code>no-referrer-when-downgrade:</code></p> <ul style="list-style-type: none"> ➤ For requests sent from a secure HTTPS context to an HTTP URL, the <code>Referer</code> header is omitted. ➤ For all other requests, the <code>Referer</code> header is set to the full URL. <p><code>origin</code></p> <ul style="list-style-type: none"> ➤ For all requests, the <code>Referer</code> header is set to only the origin. <p><code>same-origin</code></p> <ul style="list-style-type: none"> ➤ For cross-origin requests, the <code>Referer</code> header is omitted. ➤ For same-origin requests, the <code>Referer</code> header is set to the full URL. <p><code>strict-origin</code></p> <ul style="list-style-type: none"> ➤ For requests sent from a secure HTTPS context to an HTTP URL, the <code>Referer</code> header is omitted. ➤ For all other requests, the <code>Referer</code> header is set to the origin only. <p><code>origin-when-cross-origin</code></p> <ul style="list-style-type: none"> ➤ For cross-origin requests, the <code>Referer</code> header is set to the origin only. ➤ For same-origin requests, the <code>Referer</code> header is set to the full URL. <p><code>strict-origin-when-cross-origin</code></p> <ul style="list-style-type: none"> ➤ For cross-origin requests sent from a secure HTTPS context to an HTTP URL, the <code>Referer</code> header is omitted. ➤ For all other cross-origin requests, the <code>Referer</code> header is set to only the origin. ➤ For same-origin requests, the <code>Referer</code> header is set to the full URL. <p><code>unsafe-url</code></p> <ul style="list-style-type: none"> ➤ For all requests, the <code>Referer</code> header is set to the full URL. <p>Defaults to <code>no-referrer-when-downgrade</code>.</p>
signal	<p>Used to enable the ability to abort an inflight fetch via an associated <code>AbortController</code>.</p> <p>Must be an <code>AbortSignal</code> instance.</p> <p>Defaults to an unassociated <code>AbortSignal</code> instance.</p>

Common Fetch Patterns

As with `XMLHttpRequest`, `fetch()` is used both to retrieve data as well as send it. Using the `init` object, `fetch()` can be configured to send an assortment of serializable data types in the request body.

Sending JSON Data

A simple JSON string could be sent to a server as follows:

```
let payload = JSON.stringify({
  foo: 'bar'
});

let jsonHeaders = new Headers({
  'Content-Type': 'application/json'
});

fetch('/send-me-json', {
  method: 'POST', // Must use an HTTP method which sends a body
  body: payload,
  headers: jsonHeaders
});
```

Sending Parameters in a Request Body

Because the request body supports any string values, it is also easy to send parameters as a serialized body string:

```
let payload = 'foo=bar&baz=qux';

let paramHeaders = new Headers({
  'Content-Type': 'application/x-www-form-urlencoded; charset=UTF-8'
});

fetch('/send-me-params', {
  method: 'POST', // Must use an HTTP method which sends a body
  body: payload,
  headers: paramHeaders
});
```

Sending Files

Because the body supports `FormData` instances, a `fetch()` will happily serialize and send a file plucked from a file picker form input:

```
let imageFormData = new FormData();
let imageInput = document.querySelector("input[type='file']");

imageFormData.append('image', imageInput.files[0]);

fetch('/img-upload', {
  method: 'POST',
  body: imageFormData
});
```

Such a `fetch()` implementation can support multiple files as well:

```
let imageFormData = new FormData();
let imageInput = document.querySelector("input[type='file'] [multiple]");

for (let i = 0; i < imageInput.files.length; ++i) {
  imageFormData.append('image', imageInput.files[i]);
}

fetch('/img-upload', {
  method: 'POST',
  body: imageFormData
});
```

Loading Files as Blobs

The Fetch API is able to provide the response as a `Blob`, which in turn is compatible with multiple browser APIs. One common manifestation of this is explicitly loading an image file into memory and attaching it to an HTML image element. To do so, the response object exposes a `blob()` method that returns a promise that resolves to a `Blob` instance. This in turn can be passed to `URL.createObjectURL()` to generate a valid value for the image element's `src` attribute:

```
const imageElement = document.querySelector('img');

fetch('my-image.png')
  .then((response) => response.blob())
  .then((blob) => {
    imageElement.src = URL.createObjectURL(blob);
  });
```

Sending a Cross-Origin Request

Requesting a resource from a different origin requires the response to have CORS headers for the browser to accept it. Without the headers, the cross-origin request will fail and throw an error.

```
fetch('//cross-origin.com');
// TypeError: Failed to fetch
// No 'Access-Control-Allow-Origin' header is present on the requested resource.
```

If the code does not need access to the response, it is possible to send a `no-cors` fetch. In this case, the response `type` property will be `opaque`, therefore preventing you from inspecting it. This strategy can be useful for sending pings or in cases where the response can be merely cached for later use.

```
fetch('//cross-origin.com', { method: 'no-cors' })
  .then((response) => console.log(response.type));

// opaque
```

Aborting a Request

The Fetch API supports aborting a request via an `AbortController`/`AbortSignal` pair. Calling `AbortController.abort()` terminates all network transmission, so this is especially useful when you wish to halt transferring a large payload. Aborting an inflight `fetch()` will cause it to reject with an error.

```
let abortController = new AbortController();

fetch('wikipedia.zip', { signal: abortController.signal })
```

```

    .catch(() => console.log('aborted!'));

// Abort the fetch after 10ms
setTimeout(() => abortController.abort(), 10);

// aborted!

```

The Headers Object

The `Headers` object is used as a container for all outgoing requests and incoming response headers. Every outgoing `Request` instance includes an empty `Headers` instance accessible via `Request.prototype.headers`, and every incoming `Response` instance includes a populated `Headers` instance accessible via `Response.prototype.headers`—both of which are mutable properties. You can also create a fresh instance through the constructor via `new Headers()`.

Exploring Headers-Map Similarity

The `Headers` object has a high degree of overlap with the `Map` object. This should make sense, as HTTP headers are essentially serialized key-value pairs, and their JavaScript representation is the intermediate interface. The `Headers` and `Map` types share a number of instance methods: `get()`, `set()`, `has()`, and `delete()`, shown here:

```

let h = new Headers();
let m = new Map();

// Set key
h.set('foo', 'bar');
m.set('foo', 'bar');

// Check for key
console.log(h.has('foo')); // true
console.log(m.has('foo')); // true
console.log(h.has('qux')); // false
console.log(m.has('qux')); // false

// Get value
console.log(h.get('foo')); // bar
console.log(m.get('foo')); // bar

// Replace value
h.set('foo', 'baz');
m.set('foo', 'baz');

// Get replaced value
console.log(h.get('foo')); // baz
console.log(m.get('foo')); // baz

// Remove value
h.delete('foo');
m.delete('foo');

// Check that value is removed
console.log(h.get('foo')); // undefined
console.log(m.get('foo')); // undefined

```

These types can both be initialized with an iterable, as shown here:

```
let seed = [['foo', 'bar']];

let h = new Headers(seed);
let m = new Map(seed);

console.log(h.get('foo')); // bar
console.log(m.get('foo')); // bar
```

They also feature identical `keys()`, `values()`, and `entries()` iterator interfaces:

```
let seed = [['foo', 'bar'], ['baz', 'qux']];

let h = new Headers(seed);
let m = new Map(seed);

console.log(...h.keys()); // foo, baz
console.log(...m.keys()); // foo, baz

console.log(...h.values()); // bar, qux
console.log(...m.values()); // bar, qux

console.log(...h.entries()); // ['foo', 'bar'], ['baz', 'qux']
console.log(...m.entries()); // ['foo', 'bar'], ['baz', 'qux']
```

Unique Features of the Headers Object

The `Headers` object is not an exact facsimile of a `Map`. When initializing, a `Headers` object can be initialized with an object of key-value pairs, whereas a `Map` cannot:

```
let seed = {foo: 'bar'};

let h = new Headers(seed);
console.log(h.get('foo')); // bar

let m = new Map(seed);
// TypeError: object is not iterable
```

A single HTTP header may be assigned multiple values, and the `Headers` object supports this via the `append()` method. When used with a header that does not yet exist in a `Headers` instance, `append()` behaves identically to `set()`. Subsequent uses will concatenate the header value delimited with a comma:

```
let h = new Headers();

h.append('foo', 'bar');
console.log(h.get('foo')); // "bar"

h.append('foo', 'baz');
console.log(h.get('foo')); // "bar, baz"
```

Header Guards

In some cases, not all HTTP headers are mutable by the client, and the `Headers` object uses guards to enforce this. Different guard settings will change how `set()`, `append()`, and `delete()` behave. Violating the guard restrictions will throw a `TypeError`.

A `Headers` instance will behave differently based on its provenance; this behavior is governed by the guard. It is not possible to determine the guard setting of a `Headers` instance in JavaScript. The table that follows describes the various possible guard settings and the behavioral implications of each.

GUARD	APPLICABLE SCENARIO	RESTRICTIONS
none	Active when a <code>Headers</code> instance is created via its constructor.	None.
request	Active when a <code>Request</code> object is instantiated via its constructor with any mode that is not <code>no-cors</code> .	No modifications are allowed to headers with forbidden header names (https://developer.mozilla.org/en-US/docs/Glossary/Forbidden_header_name).
request-no-cors	Active when a <code>Request</code> object is instantiated via its constructor with a mode of <code>no-cors</code> .	No modifications are allowed to headers that are not simple headers (https://developer.mozilla.org/en-US/docs/Glossary/simple_header).
response	Active when a <code>Response</code> object is instantiated via its constructor.	No modifications are allowed to headers with forbidden response header names (https://developer.mozilla.org/en-US/docs/Glossary/Forbidden_response_header_name).
immutable	Active when a <code>Response</code> object is instantiated via the <code>error()</code> or <code>redirect()</code> static methods.	No header modifications are allowed.

The Request Object

As its name indicates, the `Request` object is an interface to the request for a fetched resource. This interface exposes information about the nature of the request as well as different ways of consuming the body of the request.

NOTE *The properties and methods involving the body are covered in the “Requests, Responses, and the Body Mixin” section in this chapter.*

Creating Request Objects

A `Request` object can be instantiated via a constructor. It requires an `input` argument, which will most commonly be a URL:

```
let r = new Request('https://foo.com');
console.log(r);
// Request {...}
```

The Request constructor also accepts a second optional argument, an `init` object. This `init` object is identical to that of `fetch()`, as described earlier in the chapter in the section “Custom Fetch Options.” Values not specified inside `init` will be assigned their default values in the Request instance:

```
// Creates Request object with all default values:
console.log(new Request(''));

// Request {
//   bodyUsed: false
//   cache: "default"
//   credentials: "same-origin"
//   destination: ""
//   headers: Headers {}
//   integrity: ""
//   keepalive: false
//   method: "GET"
//   mode: "cors"
//   redirect: "follow"
//   referrer: "about:client"
//   referrerPolicy: ""
//   signal: AbortSignal {aborted: false, onabort: null}
//   url: "<current URL>"
// }

// Creates Request object with specified init values:
console.log(new Request('https://foo.com',
  { method: 'POST' }));

// Request {
//   bodyUsed: false
//   cache: "default"
//   credentials: "same-origin"
//   destination: ""
//   headers: Headers {}
//   integrity: ""
//   keepalive: false
//   method: "POST"
//   mode: "cors"
//   redirect: "follow"
//   referrer: "about:client"
//   referrerPolicy: ""
//   signal: AbortSignal {aborted: false, onabort: null}
//   url: "https://foo.com/"
// }
```

Cloning Request Objects

The Fetch API offers two slightly different ways of making copies of a Request object: using the Request constructor, and using the `clone()` method.

Passing a `Request` instance as the input argument to the `Request` constructor will make a copy of that request:

```
let r1 = new Request('https://foo.com');
let r2 = new Request(r1);

console.log(r2.url); // https://foo.com/
```

Values inside the `init` object will override those of the source object:

```
let r1 = new Request('https://foo.com');
let r2 = new Request(r1, {method: 'POST'});

console.log(r1.method); // GET
console.log(r2.method); // POST
```

This copying strategy will not always yield an exact copy. Most notably, it will mark the first request body as used:

```
let r1 = new Request('https://foo.com',
  { method: 'POST', body: 'foobar' });
let r2 = new Request(r1);

console.log(r1.bodyUsed); // true
console.log(r2.bodyUsed); // false
```

If the source object has a different origin than where the new object is created, the `referrer` property is cleared. Furthermore, if the source object has a `mode` value of `navigate`, this will be converted to `same-origin`.

The second way of cloning a `Request` object is to use the `clone()` method, which creates an exact copy with no opportunity to override any values. Unlike the first technique, this will not mark any request body as used:

```
let r1 = new Request('https://foo.com', { method: 'POST', body: 'foobar' });
let r2 = r1.clone();

console.log(r1.url); // https://foo.com/
console.log(r2.url); // https://foo.com/

console.log(r1.bodyUsed); // false
console.log(r2.bodyUsed); // false
```

Cloning a `Request` using either technique is not allowed if the `bodyUsed` request property is `false`, meaning the body has not yet been read. Once the body is read, attempting to clone will throw a `TypeError`.

```
let r = new Request('https://foo.com');
r.clone();
new Request(r);
// No error

r.text(); // sets the bodyUsed field to false
```



```
r.clone();
// TypeError: Failed to execute 'clone' on 'Request': Request body is already used

new Request(r);
// TypeError: Failed to construct 'Request': Cannot construct a Request with a
Request object that has already been used.
```

Using Request Objects with fetch()

The fact that `fetch()` and the `Request` constructor have identical function signatures is no accident. When calling `fetch()`, you are able to pass an already-created `Request` instance instead of a URL. As with the `Request` constructor, values provided in the `fetch()` `init` object will override the provided request's values:

```
let r = new Request('https://foo.com');

// send GET request to foo.com
fetch(r);

// send POST request to foo.com
fetch(r, { method: 'POST' });
```

Internally, a `fetch` is cloning the provided `Request` object. As with cloning a `Request`, a `fetch` cannot be dispatched with a `Request` that has a used body:

```
let r = new Request('https://foo.com',
  { method: 'POST', body: 'foobar' });

r.text();

fetch(r);
// TypeError: Cannot construct a Request with a Request object that has already
been used.
```

Importantly, using a `Request` in a `fetch` will also serve to mark the body as used. Therefore, only a single `fetch` can be performed with a `Request` that has a body. (Requests that do not include a body are not subject to this restriction). This is demonstrated here:

```
let r = new Request('https://foo.com',
  { method: 'POST', body: 'foobar' });

fetch(r);

fetch(r);
// TypeError: Cannot construct a Request with a Request object that has already
been used.
```

In order to invoke `fetch()` multiple times with the same `Request` object that includes a body, `clone()` must be invoked prior to dispatching the first `fetch()`:

```
let r = new Request('https://foo.com',
  { method: 'POST', body: 'foobar' });

// All 3 succeed
fetch(r.clone());
fetch(r.clone());
fetch(r);
```

The Response Object

As its name indicates, the `Response` object is an interface to the response from a fetched resource. This interface exposes information about the nature of the response as well as different ways of consuming the body of the response.

NOTE *The properties and methods involving the body are covered in the section “Requests, Responses, and the Body Mixin” in this chapter.*

Creating Response Objects

A `Response` object can be instantiated via a constructor. It requires no arguments. Its properties will be populated with default values since this instance does not represent an actual HTTP response:

```
let r = new Response();
console.log(r);
// Response {
//   body: (...),
//   bodyUsed: false
//   headers: Headers {}
//   ok: true
//   redirected: false
//   status: 200
//   statusText: "OK"
//   type: "default"
//   url: ""
// }
```

The `Response` constructor accepts a first optional argument, a `body`. This `body`, which can be `null`, is identical to that of the `init` `body`, as described earlier in the chapter in the section “Custom Fetch Options.” The second optional argument, the `init` object, should be populated with any number of the keys and corresponding values in the table that follows.

KEY	VALUE
<code>headers</code>	Must be either a <code>Headers</code> object instance or regular object instance containing header key-value <code>string</code> pairs. Defaults to a <code>Headers</code> object with no key-value pairs.
<code>status</code>	The integer indicating the HTTP response status code. Defaults to 200.
<code>statusText</code>	A string describing the HTTP response status. Defaults to an empty string.

The `body` and `init` can be used to build a `Response` as follows:

```
let r = new Response('foobar', {
  status: 418,
  statusText: 'I\'m a teapot'
});
console.log(r);
```

```
// Response {  
//   body: (...)  
//   bodyUsed: false  
//   headers: Headers {}  
//   ok: false  
//   redirected: false  
//   status: 418  
//   statusText: "I'm a teapot"  
//   type: "default"  
//   url: ""  
// }
```

For most applications, the most common way of producing a `Response` object is by calling `fetch()`; this returns a promise that resolves to a `Response` object that does represent an actual HTTP response. The following code shows an example `Response` object you might expect:

```
fetch('https://foo.com')  
  .then((response) => {  
    console.log(response);  
  });  
  
// Response {  
//   body: (...)  
//   bodyUsed: false  
//   headers: Headers {}  
//   ok: true  
//   redirected: false  
//   status: 200  
//   statusText: "OK"  
//   type: "basic"  
//   url: "https://foo.com/"  
// }
```

The `Response` class also features two static methods for generating `Response` objects, `Response.redirect()` and `Response.error()`. `Response.redirect()` accepts a URL and redirect status code (301, 302, 303, 307, or 308) and returns a redirected `Response` object:

```
console.log(Response.redirect('https://foo.com', 301));  
// Response {  
//   body: (...)  
//   bodyUsed: false  
//   headers: Headers {}  
//   ok: false  
//   redirected: false  
//   status: 301  
//   statusText: ""  
//   type: "default"  
//   url: ""  
// }
```

The provided status code must qualify as a redirect; otherwise an error is thrown:

```
Response.redirect('https://foo.com', 200);  
// RangeError: Failed to execute 'redirect' on 'Response': Invalid status code
```

Also available for use is `Response.error()`. This static method produces a response that you would expect from a network error, which would cause a `fetch()` promise to reject.

```
console.log(Response.error());
// Response {
//   body: (...),
//   bodyUsed: false,
//   headers: Headers {},
//   ok: false,
//   redirected: false,
//   status: 0,
//   statusText: "",
//   type: "error",
//   url: ""
// }
```

Reading Response Status Information

The `Response` object offers a suite of read-only properties describing how the request completed, as you can see in the table that follows.

PROPERTY	VALUE
<code>headers</code>	The <code>Headers</code> object associated with the response.
<code>ok</code>	A Boolean indicating the nature of the HTTP status code. A status code of 200–299 returns <code>true</code> , other status codes <code>false</code> .
<code>redirected</code>	A Boolean indicating if the response was subjected to at least one redirect.
<code>status</code>	An integer indicating the HTTP status code of the response.
<code>statusText</code>	A string containing the canonical description associated with the HTTP status code. This value is derived from the optional HTTP Reason-Phrase field, so this field may be an empty string if the server declines to respond with a Reason-Phrase.
<code>type</code>	A string containing the type of response. It will contain one of the following string values: <ul style="list-style-type: none"> ➤ <code>basic</code>: Indicates a standard same-origin response. ➤ <code>cors</code>: Indicates a standard cross-origin response. ➤ <code>error</code>: Indicates the response object was created via <code>Response.error()</code>. ➤ <code>opaque</code>: Indicates a cross-origin response to a <code>no-cors</code> fetch. ➤ <code>opaqueredirect</code>: Indicates a response to a request with <code>redirect</code> set to <code>manual</code>.
<code>url</code>	A string containing the URL of the response. For redirected responses, this will be the final URL, which produced a non-redirect response.

The following demonstrates typical response content for URLs that return 200, 302, 404, and 500:

```
fetch('//foo.com').then(console.log);
// Response {
//   body: (...)
//   bodyUsed: false
//   headers: Headers {}
//   ok: true
//   redirected: false
//   status: 200
//   statusText: "OK"
//   type: "basic"
//   url: "https://foo.com/"
// }

fetch('//foo.com/redirect-me').then(console.log);
// Response {
//   body: (...)
//   bodyUsed: false
//   headers: Headers {}
//   ok: true
//   redirected: true
//   status: 200
//   statusText: "OK"
//   type: "basic"
//   url: "https://foo.com/redirected-url/"
// }

fetch('//foo.com/does-not-exist').then(console.log);
// Response {
//   body: (...)
//   bodyUsed: false
//   headers: Headers {}
//   ok: false
//   redirected: true
//   status: 404
//   statusText: "Not Found"
//   type: "basic"
//   url: "https://foo.com/does-not-exist/"
// }

fetch('//foo.com/throws-error').then(console.log);
// Response {
//   body: (...)
//   bodyUsed: false
//   headers: Headers {}
//   ok: false
//   redirected: true
//   status: 500
//   statusText: "Internal Server Error"
//   type: "basic"
//   url: "https://foo.com/throws-error/"
// }
```

Cloning Response Objects

The primary way of cloning a `Response` object is to use the `clone()` method, which creates an exact copy with no opportunity to override any values. This will not mark any request body as used:

```
let r1 = new Response('foobar');
let r2 = r1.clone();

console.log(r1.bodyUsed); // false
console.log(r2.bodyUsed); // false
```

Cloning a `Response` is not allowed if the `bodyUsed` request property is `false`, meaning the body has not yet been read. Once the body is read, attempting to clone will throw a `TypeError`.

```
let r = new Response('foobar');
r.clone();
// No error

r.text(); // sets the bodyUsed field to false

r.clone();
// TypeError: Failed to execute 'clone' on 'Response': Response body is
already used
```

Only a body read can be performed with a `Response` that has a body. (Responses that do not include a body are not subject to this restriction.) This is demonstrated here:

```
let r = new Response('foobar');

r.text().then(console.log); // foobar

r.text().then(console.log);
// TypeError: Failed to execute 'text' on 'Response': body stream is locked
```

In order to read the body multiple times with the same `Response` object that includes a body, `clone()` must be invoked prior to performing the first read:

```
let r = new Response('foobar');

r.clone().text().then(console.log); // foobar
r.clone().text().then(console.log); // foobar
r.text().then(console.log);         // foobar
```

Alternately, it is also possible to perform a pseudo-clone operation by creating a new `Response` instance with the original body. Importantly, this strategy will not mark the first `Response` as read, but the body is *shared* between the two responses:

```
let r1 = new Response('foobar');
let r2 = new Response(r1.body);

console.log(r1.bodyUsed); // false
console.log(r2.bodyUsed); // false

r2.text().then(console.log); // foobar
r1.text().then(console.log);
// TypeError: Failed to execute 'text' on 'Response': body stream is locked
```

Requests, Responses, and the Body Mixin

Both `Request` and `Response` incorporate the Fetch API's `Body` mixin to accommodate the payload-carrying nature of both types. This mixin confers to each type a `read-only body` (implemented as a `ReadableStream`), a `read-only bodyUsed` Boolean indicating if the `body` stream was read, and a handful of methods that read the stream to completion and convert the result into a certain JavaScript object type.

Generally, there are two primary reasons to consume a `Request` or `Response` body as a stream: Either network latency is a factor due to the size of the payload, or the stream API itself is inherently useful for processing the payload. In almost all other cases, the body of a fetched resource will be most useful when consumed all at once.

The `Body` mixin affords you five different methods which flush the `ReadableStream` into a single buffer in memory, cast the buffer into a certain JavaScript object type, and produce it inside a promise. This promise will wait until the body stream reports as finished and the buffer is parsed before resolving. This means you must wait for the fetched resource to be fully loaded on the client before being able to access its contents.

Body.text()

The `Body.text()` method returns a promise that resolves with the flushed buffer decoded as a UTF-8 string. Use of `Body.text()` is shown here with a `Response` object:

```
fetch('https://foo.com')
  .then((response) => response.text())
  .then(console.log);

// <!doctype html><html lang="en">
// <head>
// <meta charset="utf-8">
// ...
```

Use of `Body.text()` is shown here with a `Request` object:

```
let request = new Request('https://foo.com',
  { method: 'POST', body: 'barbazqux' });

request.text()
  .then(console.log);

// barbazqux
```

Body.json()

The `Body.json()` method returns a promise that resolves with the flushed buffer decoded as JSON. Use of `Body.json()` is shown here with a `Response` object:

```
fetch('https://foo.com/foo.json')
  .then((response) => response.json())
  .then(console.log);

// {"foo": "bar"}
```

Use of `Body.json()` is shown here with a `Request` object:

```
let request = new Request('https://foo.com',
                          { method: 'POST', body: JSON.stringify({ bar: 'baz' }) });

request.json()
  .then(console.log);

// {bar: 'baz'}
```

Body.formData()

Browsers are able to serialize/deserialize `FormData` objects as a body. For example, consider the following `FormData` instance:

```
let myFormData = new FormData();
myFormData.append('foo', 'bar');
```

When transmitted via HTTP, a WebKit browser might serialize this as follows:

```
-----WebKitFormBoundarydR9Q2kOzE6nbN7eR
Content-Disposition: form-data; name="foo"

bar
-----WebKitFormBoundarydR9Q2kOzE6nbN7eR--
```

The `Body.formData()` method returns a promise that resolves with the flushed buffer decoded as a `FormData` instance. Use of `Body.formData()` is shown here with a `Response` object:

```
fetch('https://foo.com/form-data')
  .then((response) => response.formData())
  .then((formData) => console.log(formData.get('foo')));

// bar
```

Use of `Body.formData()` is shown here with a `Request` object:

```
let myFormData = new FormData();
myFormData.append('foo', 'bar');

let request = new Request('https://foo.com',
                          { method: 'POST', body: myFormData });

request.formData()
  .then((formData) => console.log(formData.get('foo')));

// bar
```

Body.arrayBuffer()

You may find the need to inspect and modify the body payload as raw binary. For such a task, the body can be converted to an `ArrayBuffer` instance using `Body.arrayBuffer()`. This method returns a promise that resolves with the flushed buffer exposed as an `ArrayBuffer`. Use of `Body.arrayBuffer()` is shown here with a `Response` object:

```
fetch('https://foo.com')
  .then((response) => response.arrayBuffer())
```



```
    .then(console.log);

// ArrayBuffer(...) {}

Use of Body.arrayBuffer() is shown here with a Request object:

let request = new Request('https://foo.com',
    { method:'POST', body: 'abcdefg' });

// Logs the encoded string binary values as integers
request.arrayBuffer()
    .then((buf) => console.log(new Int8Array(buf)));

// Int8Array(7) [97, 98, 99, 100, 101, 102, 103]
```

Body.blob()

You may find the need to use the body payload as raw binary without inspection or modification. For such a task, the body can be used as a `Blob` instance using `Body.blob()`. This method returns a promise that resolves with the flushed buffer exposed as a `Blob`. Use of `Body.blob()` is shown here with a `Response` object:

```
fetch('https://foo.com')
    .then((response) => response.blob())
    .then(console.log);

// Blob(...) {size:..., type: "..."}
```

Use of `Body.blob()` is shown here with a `Request` object:

```
let request = new Request('https://foo.com',
    { method:'POST', body: 'abcdefg' });

request.blob()
    .then(console.log);

// Blob(7) {size: 7, type: "text/plain;charset=utf-8"}
```

Single-Use Streams

Because the `Body` mixin is built atop a `ReadableStream`, this means that the body stream can only be read a single time. The implication of this is that all of the `Body` mixin methods can only be called a single time; subsequent attempts to invoke a mixin method will throw an error.

```
fetch('https://foo.com')
    .then((response) => response.blob().then(() => response.blob()));

// TypeError: Failed to execute 'blob' on 'Response': body stream is locked
let request = new Request('https://foo.com',
    { method: 'POST', body: 'foobar' });

request.blob().then(() => request.blob());
// TypeError: Failed to execute 'blob' on 'Request': body stream is locked
```

Even if the stream is merely in the process of being read, all of these methods will place a lock on the `ReadableStream` as soon as they are called and prevent a second reader from accessing the stream:

```
fetch('https://foo.com')
  .then((response) => {
    response.blob(); // First call locks the stream
    response.blob(); // Second call attempts to lock the stream and fails
  });

// TypeError: Failed to execute 'blob' on 'Response': body stream is locked
let request = new Request('https://foo.com',
  { method: 'POST', body: 'foobar' });

request.blob(); // First call locks the stream
request.blob(); // Second call attempts to lock the stream and fails
// TypeError: Failed to execute 'blob' on 'Request': body stream is locked
```

As part of the `Body` mixin, a `bodyUsed` Boolean property indicates if the `ReadableStream` is *disturbed*, meaning a reader has already placed a lock on the stream. This doesn't necessarily indicate that the stream is fully drained. This property is demonstrated here:

```
let request = new Request('https://foo.com',
  { method: 'POST', body: 'foobar' });
let response = new Response('foobar');

console.log(request.bodyUsed); // false
console.log(response.bodyUsed); // false

request.text().then(console.log); // foobar
response.text().then(console.log); // foobar

console.log(request.bodyUsed); // true
console.log(response.bodyUsed); // true
```

Using a `ReadableStream` Body

Much of JavaScript programming treats networking as atomic operations; requests are created and sent off all at once, and responses are exposed as a unified data payload that becomes available all at once. This convention hides the underlying messiness, making network-involved code nice to write.

By the very nature of TCP/IP, transmitted data arrives at an endpoint in chunks, and only as fast as the network can deliver those chunks. A receiving endpoint allocates memory and writes what is received over the network as it arrives. The Fetch API allows you to read and manipulate this data as it arrives in real time via a `ReadableStream`.

NOTE *Examples in this section will fetch the HTML of the Fetch specification, found at <https://fetch.spec.whatwg.org/>. This page has roughly 1MB of markup, which is a large enough payload that the stream examples in this section will arrive in multiple chunks.*

A `ReadableStream`, as defined in the Stream API, exposes a `getReader()` method that produces a `ReadableStreamDefaultReader`, which can be used to asynchronously retrieve chunks of the body as they arrive. Each chunk of the body stream is provided as a `Uint8Array`.

The following snippet invokes `read()` on the reader to log the first available chunk:

```
fetch('https://fetch.spec.whatwg.org/')
  .then((response) => response.body)
  .then((body) => {
    let reader = body.getReader();

    console.log(reader); // ReadableStreamDefaultReader {}

    reader.read()
      .then(console.log);
  });

// { value: Uint8Array{}, done: false }
```

To retrieve the entire payload as it becomes available, the `read()` method can be called recursively:

```
fetch('https://fetch.spec.whatwg.org/')
  .then((response) => response.body)
  .then((body) => {
    let reader = body.getReader();

    function processNextChunk({value, done}) {
      if (done) {
        return;
      }

      console.log(value);

      return reader.read()
        .then(processNextChunk);
    }

    return reader.read()
      .then(processNextChunk);
  });

// { value: Uint8Array{}, done: false }
// { value: Uint8Array{}, done: false }
// { value: Uint8Array{}, done: false }
// ...
```

Async functions are highly appropriate for use in `fetch()` operations. This recursive implementation can be flattened using `async/await`:

```
fetch('https://fetch.spec.whatwg.org/')
  .then((response) => response.body)
  .then(async function(body) {
    let reader = body.getReader();

    while(true) {
      let { value, done } = await reader.read();
    }
  });
```

```

        if (done) {
            break;
        }

        console.log(value);
    }
});

// { value: Uint8Array{}, done: false }
// { value: Uint8Array{}, done: false }
// { value: Uint8Array{}, done: false }
// ...

```

Alternately, the `read()` method is close enough to the `Iterable` interface that it is trivial to convert this to use a `for-await-of` loop:

```

fetch('https://fetch.spec.whatwg.org/')
  .then((response) => response.body)
  .then(async function(body) {
    let reader = body.getReader();

    let asyncIterable = {
      [Symbol.asyncIterator]() {
        return {
          next() {
            return reader.read();
          }
        };
      }
    };

    for await (chunk of asyncIterable) {
      console.log(chunk);
    }
  });

// { value: Uint8Array{}, done: false }
// { value: Uint8Array{}, done: false }
// { value: Uint8Array{}, done: false }
// ...

```

This can be reduced further into a slightly cleaner generator function. Furthermore, this implementation can be made more robust by allowing for a partial stream read. If the stream terminates either via depletion or throwing an error, the reader should release the lock to allow for a different stream reader to pick up where it left off:

```

async function* streamGenerator(stream) {
  const reader = stream.getReader();

  try {
    while (true) {
      const { value, done } = await reader.read();
    }
  }
}

```

```
        if (done) {
            break;
        }

        yield value;
    }
} finally {
    reader.releaseLock();
}
}

fetch('https://fetch.spec.whatwg.org/')
    .then((response) => response.body)
    .then(async function(body) {
        for await (chunk of streamGenerator(body)) {
            console.log(chunk);
        }
    });
```

In these examples, after the current `Uint8Array` chunk goes out of scope, the browser marks it as eligible for garbage collection. This allows for potentially massive memory savings in scenarios where it is suitable to examine a large payload serially and in discrete segments.

The size of the buffer and whether or not the browser waits for it to be filled before pushing it into the stream is subject to the JavaScript runtime's implementation. The browser is sensitive to the fact that it is ideal to wait and fill up an allocated buffer when possible, but at the same time to keep the stream full by sending (sometimes unfilled) buffers as often as possible.

Browsers may vary the size of the chunk's buffer based on factors such as bandwidth or network latency. Furthermore, the browser might decide to send a partially filled buffer to the stream if it decides not to wait for the network. Ultimately, your code should be prepared to handle the following:

- ▶ `Uint8Array` chunks of variable size
- ▶ `Uint8Array` chunks being partially filled
- ▶ Chunks arriving at unpredictable intervals

By default, chunks will arrive in a `Uint8Array` format. Because the termination of a chunk does not respect the encoded content, there may be values such as multi-byte characters split between two separate sequential chunks. There are messy ways to manually account for this, but for many cases there are plug-and-play solutions from the Encoding API.

To convert the `Uint8Array` to readable text, a `TextDecoder` can be passed a buffer and return the converted value. Setting the `stream:true` configuration allows it to keep the previous buffer in memory so that content bridged between the two chunks can be correctly decoded:

```
let decoder = new TextDecoder();

async function* streamGenerator(stream) {
    const reader = stream.getReader();

    try {
```

```

    while (true) {
      const { value, done } = await reader.read();

      if (done) {
        break;
      }

      yield value;
    }
  } finally {
    reader.releaseLock();
  }
}

fetch('https://fetch.spec.whatwg.org/')
  .then((response) => response.body)
  .then(async function(body) {
    for await (chunk of streamGenerator(body)) {
      console.log(decoder.decode(chunk, { stream: true }));
    }
  });

// <!doctype html><html lang="en"> ...
// whether a <a data-link-type="dfn" href="#concept-header" ...
// result to <var>rangeValue</var>. ...
// ...

```

Because a `Response` object can be created using a `ReadableStream`, it is possible to read a stream, pipe it into a newly created secondary stream, and use that secondary stream for `Body` methods such as `text()`. This allows for inspection and manipulation of the stream contents as they become available. This dual-stream technique is shown here:

```

fetch('https://fetch.spec.whatwg.org/')
  .then((response) => response.body)
  .then((body) => {
    const reader = body.getReader();

    // create secondary stream
    return new ReadableStream({
      async start(controller) {
        try {
          while (true) {
            const { value, done } = await reader.read();

            if (done) {
              break;
            }

            // Push the body stream's chunk onto the secondary stream
            controller.enqueue(value);
          }
        } finally {
          controller.close();
          reader.releaseLock();
        }
      }
    });
  });

```

```

    })
  })
})
.then((secondaryStream) => new Response(secondaryStream))
.then(response => response.text())
.then(console.log);

// <!doctype html><html lang="en"><head><meta charset="utf-8"> ...

```

THE BEACON API

To maximize the amount of information transmitted about a page, many analytics tools need to send telemetry or analytics data to a server as late in a page’s lifecycle as possible. As a result, the optimal pattern is to send a network request on the browser’s `unload` event. This event signals that a page departure is occurring and that no more useful information will be generated on that page.

When an `unload` event is fired, analytics tools want to cease collecting information and attempt to ship off what they have to the server. This presents a problem, as the `unload` event means to the browser that there is little reason to dispatch any pending network requests (since the page is being discarded anyway). For example, any asynchronous requests created in an `unload` handler will be cancelled by the browser. Therefore, an asynchronous `XMLHttpRequest` or `fetch()` is unsuitable for this task. Analytics tools could use a synchronous `XMLHttpRequest` to force delivery of the request, but doing so causes user experience problems. Because the browser pauses waiting for the request to return, navigation to the next page is delayed while the browser waits for the `unload` handler inside the `unload` handler to complete.

To address this issue, a supplemental Beacon API was introduced by the W3C. The API adds a single `sendBeacon()` method to the `navigator` object. This simple method accepts a URL and a data payload and dispatches a POST request. The optional data payload can be an `ArrayBufferView`, a `Blob`, a `DOMString`, or a `FormData` instance. The method returns `true` if the request was successfully enqueued for eventual transmission, else `false`.

The method can be used as follows:

```

// Sends POST request
// URL: 'https://example.com/analytics-reporting-url'
// Request Payload: '{foo: "bar"}'

navigator.sendBeacon('https://example.com/analytics-reporting-url', '{foo: "bar"}');

```

This method may seem like mere syntactical sugar for a POST request, but there are several notable features of the method:

- `sendBeacon()` is not restricted to the end of a page’s lifecycle, it can be used at any time.
- Once `sendBeacon()` is called, the browser adds the requests to an internal request queue. The browser will eagerly attempt to send requests in the queue.
- The browser guarantees it will attempt to send the request even if the browser has already torn down the original page.

- Response codes, timeouts, and any other network failures are totally opaque and cannot be handled programmatically.
- The beacon request is sent with all relevant cookies at the time `sendBeacon()` was originally invoked.

WEB SOCKETS

The goal of Web Sockets is to provide full-duplex, bidirectional communication with the server over a single, long-lasting connection. When a Web Socket is created in JavaScript, an HTTP request is sent to the server to initiate a connection. When the server responds, the connection uses the HTTP Upgrade header to switch from HTTP to the Web Socket protocol. This means that Web Sockets cannot be implemented with a standard HTTP server and must use a specialized server supporting the protocol to work properly.

Because Web Sockets uses a custom protocol, the URL scheme is slightly different. Instead of using the `http://` or `https://` schemes, there are `ws://` for an unsecured connection and `wss://` for a secured connection. When specifying a Web Socket URL, you must include the scheme since other schemes may be supported in the future.

The advantage of using a custom protocol over HTTP is that very small amounts of data, unencumbered by the byte overhead of HTTP, can be sent between the client and the server. Using smaller data packets makes Web Sockets ideal for mobile applications where bandwidth and latency are a problem. The disadvantage of using a custom protocol is that it has taken longer to define protocol than the JavaScript API. Web sockets are supported in all major browsers.

The API

To create a new Web Socket, instantiate a `WebSocket` object and pass in the URL that will provide the connection:

```
let socket = new WebSocket("ws://www.example.com/server.php");
```

Note that you must pass in an absolute URL to the `WebSocket` constructor. The same-origin policy does not apply to Web Sockets, so you can open a connection to any site. It is completely up to the server whether or not it will communicate with a page from a particular origin. (It can determine from where the request originated using information in the handshake.)

The browser attempts to create the connection as soon as the `WebSocket` object is instantiated. Similar to XHR, `WebSocket` has a `readyState` property that indicates the current state. The values, however, are different from those for XHR and are as follows:

- `WebSocket.OPENING` (0)—The connection is being established.
- `WebSocket.OPEN` (1)—The connection has been established.
- `WebSocket.CLOSING` (2)—The connection is beginning to close.
- `WebSocket.CLOSE` (3)—The connection is closed.

There is no `readystatechange` event for `WebSocket`; however, there are other events that correspond to the various states. The `readyState` always starts at 0.

You can close a Web Socket connection at any time using the `close()` method:

```
socket.close();
```

Upon calling `close()`, the `readyState` immediately changes to 2 (closing) and will transition to 3 when complete.

Sending/Receiving Data

Once a Web Socket is open, you can both send data over and receive data from the connection. To send data to the server, use the `send()` method and pass in a string, `ArrayBuffer`, or `Blob`, as shown here:

```
let socket = new WebSocket("ws://www.example.com/server.php");

let stringData = "Hello world!";
let arrayBufferData = Uint8Array.from(['f', 'o', 'o']);
let blobData = new Blob(['f', 'o', 'o']);

socket.send(stringData);
socket.send(arrayBufferData.buffer);
socket.send(blobData);
```

When the server sends a message to the client, a message event is fired on the `WebSocket` object. The message event works similar to other messaging protocols, with the payload available through the `event.data` property:

```
socket.onmessage = function(event) {
  let data = event.data;
  // do something with data
};
```

Similar to data that is sent to the server via `send()`, data returned in `event.data` can be procured as an `ArrayBuffer` or a `Blob`. This is governed by the `binaryType` of the `WebSocket` object, which can either be "blob" or "arraybuffer".

Other Events

The `WebSocket` object has three more events that fire during the lifetime of the connection:

- `open`—Fires when the connection has been successfully made.
- `error`—Fires when an error occurs. The connection is unable to persist.
- `close`—Fires when the connection is closed.

The `WebSocket` object doesn't support DOM Level 2 event listeners, so you need to use DOM Level 0 style event handlers for each:

```
let socket = new WebSocket("ws://www.example.com/server.php");
socket.onopen = function() {
  alert("Connection established.");
};
```

```

};
socket.onerror = function() {
    alert("Connection error.");
};
socket.onclose = function() {
    alert("Connection closed.");
};

```

Of these three events, only the `close` event has additional information on the event object. There are three additional properties on the event object: `wasClean`, a Boolean indicating if the connection was closed cleanly; `code`, a numeric status code sent from the server; and `reason`, a string containing a message sent from the server. You may want to use this information either to display to the user or to log for analytics:

```

socket.onclose = function(event) {
    console.log(`as clean? ${event.wasClean} Code=${event.code} Reason=${event.reason}`);
};

```

SECURITY

A lot has been published about Ajax security; in fact, there are entire books dedicated to the topic. Security considerations for large-scale Ajax applications are vast, but there are some basic things to understand about Ajax security in general.

First, any URL that can be accessed via Ajax can also be accessed by a browser or a server. For example, consider the following URL:

```
/getuserinfo.php?id=23
```

If a request is made to this URL, it will presumably return some data about a user whose ID is 23. There is nothing to stop someone from changing the URL to a user ID of 24 or 56 or any other value. The `getuserinfo.php` file must know whether the requestor actually has access to the data that is being requested; otherwise, you have left the server wide open to relay data about anyone.

When an unauthorized system is able to access a resource, it is considered a cross-site request forgery (CSRF) attack. The unauthorized system is making itself appear to be legitimate to the server handling the request. Ajax applications, large and small, have been affected by CSRF attacks ranging from benign proof-of-vulnerability attacks to malicious data-stealing or data-destroying attacks.

The prevailing theory of how to secure URLs accessed via Ajax is to validate that the sender has access to the resource. This can be done in the following ways:

- Requiring SSL to access resources that can be requested via Ajax
- Requiring a computed token to be sent along with every request

Please recognize that the following are ineffective against CSRF attacks:

- Requiring a POST instead of a GET—This is easily changed.
- Using the referrer as a determination of origin—Referrers are easily spoofed.
- Validating based on cookie information—Also easily spoofed.

SUMMARY

Ajax is a method for retrieving data from the server without refreshing the current page. Ajax has the following characteristics:

- The central object responsible for the growth of Ajax is the `XMLHttpRequest` (XHR) object.
- This object was created by Microsoft and first introduced in Internet Explorer 5 as a way to retrieve XML data from the server in JavaScript.
- Since that time, Firefox, Safari, Chrome, and Opera have all duplicated the implementation, and the W3C has written a specification defining the XHR behavior, making XHR a Web standard.
- Though there are some differences in implementations, the basic usage of the XHR object is relatively normalized across all browsers and can therefore safely be used in web applications.

One of the major constraints on XHR is the same-origin policy that limits communication to the same domain, using the same port, and with the same protocol. Any attempts to access resources outside of these restrictions cause a security error, unless an approved cross-domain solution is used. The solution is called Cross-Origin Resource Sharing (CORS) and is supported natively through the XHR object. Image pings and JSONP are other techniques for cross-domain communication, though they are less robust than CORS.

The Fetch API was introduced as an end-to-end replacement of the incumbent XHR object. The API offers a superior promise-based structure, a more intuitive interface, and first-class support for the Stream API.

Web Sockets are a full-duplex, bidirectional communication channel with the server. Unlike other solutions, Web Sockets do not use HTTP but rather use a custom protocol designed to deliver small pieces of data quickly. This requires a different web server but gives a speed advantage.

25

Client-Side Storage

WHAT'S IN THIS CHAPTER?

- Cookies
- Browser storage APIs
- IndexedDB

WROX.COM DOWNLOADS FOR THIS CHAPTER

Please note that all the code examples for this chapter are available as a part of this chapter's code download on the book's website at www.wrox.com/go/projavascript4e on the Download Code tab.

Along with the emergence of web applications came a call for the ability to store user information directly on the client. The idea is logical: information pertaining to a specific user should live on that user's machine. Whether that is login information, preferences, or other data, web application providers found themselves searching for ways to store data on the client. The first solution to this problem came in the form of cookies, a creation of the old Netscape Communications Corporation and described in a specification titled *Persistent Client State: HTTP Cookies* (still available at http://curl.haxx.se/rfc/cookie_spec.html). Today, cookies are just one option available for storing data on the client.

COOKIES

HTTP cookies, commonly just called *cookies*, were originally intended to store session information on the client. The specification called for the server to send a `Set-Cookie` HTTP header containing session information as part of any response to an HTTP request. For instance, the headers of a server response may look like this:

```
HTTP/1.1 200 OK
Content-type: text/html
Set-Cookie: name=value
Other-header: other-header-value
```

This HTTP response sets a cookie with the name of "name" and a value of "value". Both the name and the value are URL-encoded when sent. Browsers store such session information and send it back to the server via the `Cookie` HTTP header for every request after that point, such as the following:

```
GET /index.js1 HTTP/1.1
Cookie: name=value
Other-header: other-header-value
```

This extra information being sent back to the server can be used to uniquely identify the client from which the request was sent.

Restrictions

Cookies are, by nature, tied to a specific domain. When a cookie is set, it is sent along with requests to the same domain from which it was created. This restriction ensures that information stored in cookies is available only to approved recipients and cannot be accessed by other domains.

Because cookies are stored on the client computer, restrictions have been put in place to ensure that cookies can't be used maliciously and that they won't take up too much disk space.

In general, if you use the following approximate limits, you will run into no problems across all browser traffic:

- 300 cookies total
- 4096 bytes per cookie
- 20 cookies per domain
- 81920 bytes per domain

The total number of cookies per domain is limited, although it varies from browser to browser. For example:

- Latest editions of Internet Explorer and Edge limit cookies to 50 per domain.
- Latest editions of Firefox limit cookies to 150 per domain.
- Latest editions of Opera limit cookies to 180 per domain.
- Safari and Chrome have no hard limit on the number of cookies per domain.

When cookies are set above the per-domain limit, the browser starts to eliminate previously set cookies. Internet Explorer and Opera begin by removing the least recently used (LRU) cookie to allow space for the newly set cookie. Firefox seemingly randomly decides which cookies to eliminate, so it's very important to mind the cookie limit to avoid unintended consequences.

There are also limitations as to the size of cookies in browsers. Most browsers have a byte-count limit of around 4096 bytes, give or take a byte. For best cross-browser compatibility, it's best to keep the total cookie size to 4095 bytes or less. The size limit applies to all cookies for a domain, not per cookie.

If you attempt to create a cookie that exceeds the maximum cookie size, the cookie is silently dropped. Note that one character typically takes one byte, unless you're using multibyte characters—such as some UTF-8 Unicode characters, which can be up to 4 bytes per character.

Cookie Parts

Cookies are made up of the following pieces of information stored by the browser:

- **Name**—Unique name to identify the cookie. Cookie names are case-insensitive, so `myCookie` and `MyCookie` are considered to be the same. In practice, however, it's always best to treat the cookie names as case-sensitive because some server software may treat them as such. The cookie name must be URL-encoded.
- **Value**—String value stored in the cookie. This value must also be URL-encoded.
- **Domain**—Domain for which the cookie is valid. All requests sent from a resource at this domain will include the cookie information. This value can include a subdomain (such as `www.wrox.com`) or exclude it (such as `.wrox.com`, which is valid for all subdomains of `wrox.com`). If not explicitly set, the domain is assumed to be the one from which the cookie was set.
- **Path**—Path within the specified domain for which the cookie should be sent to the server. For example, you can specify that the cookie be accessible only from `http://www.wrox.com/books/` so pages at `http://www.wrox.com` won't send the cookie information, even though the request comes from the same domain.
- **Expiration**—Time stamp indicating when the cookie should be deleted (that is, when it should stop being sent to the server). By default, all cookies are deleted when the browser session ends; however, it is possible to set another time for the deletion. This value is set as a date in GMT format (`Wdy, DD-Mon-YYYY HH:MM:SS GMT`) and specifies an exact time when the cookie should be deleted. Because of this, a cookie can remain on a user's machine even after the browser is closed. Cookies can be deleted immediately by setting an expiration date that has already occurred.
- **Secure flag**—When specified, the cookie information is sent to the server only if an SSL connection is used. For instance, requests to `https://www.wrox.com` should send cookie information, whereas requests to `http://www.wrox.com` should not.

Each piece of information is specified as part of the `Set-Cookie` header using a semicolon-space combination to separate each section, as shown in the following example:

```
HTTP/1.1 200 OK
Content-type: text/html
Set-Cookie: name=value; expires=Mon, 22-Jan-07 07:10:24 GMT; domain=.wrox.com
Other-header: other-header-value
```

This header specifies a cookie called "name" that expires on Monday, January 22, 2007, at 7:10:24 GMT and is valid for `www.wrox.com` and any other subdomains of `wrox.com` such as `p2p.wrox.com`.

The `secure` flag is the only part of a cookie that is not a name-value pair; the word "secure" is simply included. Consider the following example:

```
HTTP/1.1 200 OK
Content-type: text/html
Set-Cookie: name=value; domain=.wrox.com; path=/; secure
Other-header: other-header-value
```

Here, a cookie is created that is valid for all subdomains of `wrox.com` and all pages on that domain (as specified by the `path` argument). This cookie can be transmitted only over an SSL connection because the `secure` flag is included.

It's important to note that the domain, path, expiration date, and `secure` flag are indications to the browser as to when the cookie should be sent with a request. These arguments are not actually sent as part of the cookie information to the server; only the name-value pairs are sent.

Cookies in JavaScript

Dealing with cookies in JavaScript is a little complicated because of a notoriously poor interface, the BOM's `document.cookie` property. This property is unique in that it behaves very differently depending on how it is used. When used to retrieve the property value, `document.cookie` returns a string of all cookies available to the page (based on the domain, path, expiration, and security settings of the cookies) as a series of name-value pairs separated by semicolons, as in the following example:

```
name1=value1;name2=value2;name3=value3
```

All of the names and values are URL-encoded and so must be decoded via `decodeURIComponent()`.

When used to set a value, the `document.cookie` property can be set to a new cookie string. That cookie string is interpreted and added to the existing set of cookies. Setting `document.cookie` does not overwrite any cookies unless the name of the cookie being set is already in use. The format to set a cookie is as follows, and is the same format used by the `Set-Cookie` header:

```
name=value; expires=expiration_time; path=domain_path; domain=domain_name; secure
```

Of these parameters, only the cookie's name and value are required. Here's a simple example:

```
document.cookie = "name=Nicholas";
```

This code creates a session cookie called "name" that has a value of "Nicholas". This cookie will be sent every time the client makes a request to the server; it will be deleted when the browser is closed. Although this will work, as there are no characters that need to be encoded in either the name or the value, it's a best practice to always use `encodeURIComponent()` when setting a cookie, as shown in the following example:

```
document.cookie = encodeURIComponent("name") + "=" +
    encodeURIComponent("Nicholas");
```

To specify additional information about the created cookie, just append it to the string in the same format as the `Set-Cookie` header, like this:

```
document.cookie = encodeURIComponent("name") + "=" +
    encodeURIComponent("Nicholas") + "; domain=.wrox.com; path=/";
```

Because the reading and writing of cookies in JavaScript isn't very straightforward, functions are often used to simplify cookie functionality. There are three basic cookie operations: reading, writing, and deleting. These are all represented in the `CookieUtil` object as follows:

```
class CookieUtil {
  static get(name) {
    let cookieName = `${encodeURIComponent(name)}=`,
        cookieStart = document.cookie.indexOf(cookieName),
        cookieValue = null;

    if (cookieStart > -1){
      let cookieEnd = document.cookie.indexOf(";", cookieStart);
      if (cookieEnd == -1){
        cookieEnd = document.cookie.length;
      }
      cookieValue = decodeURIComponent(document.cookie.substring(cookieStart
        + cookieName.length, cookieEnd));
    }

    return cookieValue;
  }

  static set(name, value, expires, path, domain, secure) {
    let cookieText =
      `${encodeURIComponent(name)}=${encodeURIComponent(value)}`;

    if (expires instanceof Date) {
      cookieText += `; expires=${expires.toGMTString()}`;
    }

    if (path) {
      cookieText += `; path=${path}`;
    }

    if (domain) {
      cookieText += `; domain=${domain}`;
    }

    if (secure) {
      cookieText += "; secure";
    }

    document.cookie = cookieText;
  }

  static unset(name, path, domain, secure) {
    CookieUtil.set(name, "", new Date(0), path, domain, secure);
  }
};
```

The `CookieUtil.get()` method retrieves the value of a cookie with the given name. To do so, it looks for the occurrence of the cookie name followed by an equal sign in `document.cookie`. If that pattern is found, then `indexOf()` is used to find the next semicolon after that location (which indicates the end of the cookie). If the semicolon isn't found, this means that the cookie is the last

one in the string, so the entire rest of the string should be considered the cookie value. This value is decoded using `decodeURIComponent()` and returned. In the case where the cookie isn't found, `null` is returned.

The `CookieUtil.set()` method sets a cookie on the page and accepts several arguments: the name of the cookie, the value of the cookie, an optional `Date` object indicating when the cookie should be deleted, an optional URL path for the cookie, an optional domain for the cookie, and an optional Boolean value indicating if the `secure` flag should be added. The arguments are in the order in which they are most frequently used, and only the first two are required. Inside the method, the name and value are URL-encoded using `encodeURIComponent()`, and then the other options are checked. If the `expires` argument is a `Date` object, then an `expires` option is added using the `Date` object's `toGMTString()` method to format the date correctly. The rest of the method simply builds up the cookie string and sets it to `document.cookie`.

There is no direct way to remove existing cookies. Instead, you need to set the cookie again—with the same path, domain, and secure options—and set its expiration date to some time in the past. The `CookieUtil.unset()` method handles this case. It accepts four arguments: the name of the cookie to remove, an optional path argument, an optional domain argument, and an optional secure argument.

These arguments are passed through to `CookieUtil.set()` with the value set to a blank string and the expiration date set to January 1, 1970 (the value of a `Date` object initialized to 0 milliseconds). Doing so ensures that the cookie is removed.

These methods can be used as follows:

```
// set cookies
CookieUtil.set("name", "Nicholas");
CookieUtil.set("book", "Professional JavaScript");

// read the values
alert(CookieUtil.get("name")); // "Nicholas"
alert(CookieUtil.get("book")); // "Professional JavaScript"

// remove the cookies
CookieUtil.unset("name");
CookieUtil.unset("book");

// set a cookie with path, domain, and expiration date
CookieUtil.set("name", "Nicholas", "/books/projs/", "www.wrox.com",
    new Date("January 1, 2010"));

// delete that same cookie
CookieUtil.unset("name", "/books/projs/", "www.wrox.com");

// set a secure cookie
CookieUtil.set("name", "Nicholas", null, null, null, true);
```

These methods make using cookies to store data on the client easier by handling the parsing and cookie string construction tasks.

Subcookies

To get around the per-domain cookie limit imposed by browsers, some developers use a concept called *subcookies*. Subcookies are smaller pieces of data stored within a single cookie. The idea is to use the cookie's value to store multiple name-value pairs within a single cookie. The most common format for subcookies is as follows:

```
name=name1=value1&name2=value2&name3=value3&name4=value4&name5=value5
```

Subcookies tend to be formatted in query string format. These values can then be stored and accessed using a single cookie, rather than using a different cookie for each name-value pair. The result is that more structured data can be stored by a website or web application without reaching the per-domain cookie limit.

To work with subcookies, you need a new set of methods. The parsing and serialization of subcookies are slightly different and a bit more complicated because of the expected subcookie usage. To get a subcookie, for example, you need to follow the same basic steps to get a cookie, but before decoding the value, you need to find the subcookie information as follows:

```
class SubCookieUtil {
  static get(name, subName) {
    let subCookies = SubCookieUtil.getAll(name);
    return subCookies ? subCookies[subName] : null;
  }

  static getAll(name) {
    let cookieName = encodeURIComponent(name) + "=",
        cookieStart = document.cookie.indexOf(cookieName),
        cookieValue = null,
        cookieEnd,
        subCookies,
        parts,
        result = {};

    if (cookieStart > -1) {
      cookieEnd = document.cookie.indexOf(";", cookieStart);
      if (cookieEnd == -1) {
        cookieEnd = document.cookie.length;
      }
      cookieValue = document.cookie.substring(cookieStart +
                                              cookieName.length, cookieEnd);

      if (cookieValue.length > 0) {
        subCookies = cookieValue.split("&");

        for (let i = 0, len = subCookies.length; i < len; i++) {
          parts = subCookies[i].split("=");
          result[decodeURIComponent(parts[0])] =
            decodeURIComponent(parts[1]);
        }
      }

      return result;
    }
  }
}
```

```
        return null;
    }

    // more code here
};
```

There are two methods for retrieving subcookies: `get()` and `getAll()`. Whereas `get()` retrieves a single subcookie value, `getAll()` retrieves all subcookies and returns them in an object whose properties are equal to the subcookie names and the values are equal to the subcookie values. The `get()` method accepts two arguments: the name of the cookie and the name of the subcookie. It simply calls `getAll()` to retrieve all of the subcookies and then returns just the one of interest (or `null` if the cookie doesn't exist).

The `SubCookieUtil.getAll()` method is very similar to `CookieUtil.get()` in the way it parses a cookie value. The difference is that the cookie value isn't immediately decoded. Instead, it is split on the ampersand character to get all subcookies into an array. Then, each subcookie is split on the equal sign so that the first item in the `parts` array is the subcookie name, and the second is the subcookie value. Both items are decoded using `decodeURIComponent()` and assigned on the `result` object, which is returned as the method value. If the cookie doesn't exist, then `null` is returned.

These methods can be used as follows:

```
// assume document.cookie=data=name=Nicholas&book=Professional%20JavaScript

// get all subcookies
let data = SubCookieUtil.getAll("data");
alert(data.name); // "Nicholas"
alert(data.book); // "Professional JavaScript"

// get subcookies individually
alert(SubCookieUtil.get("data", "name")); // "Nicholas"
alert(SubCookieUtil.get("data", "book")); // "Professional JavaScript"
```

To write subcookies, you can use two methods: `set()` and `setAll()`. The following code shows their constructs:

```
class SubCookieUtil {
    // previous code here

    static set(name, subName, value, expires, path, domain, secure) {
        let subcookies = SubCookieUtil.getAll(name) || {};
        subcookies[subName] = value;
        SubCookieUtil.setAll(name, subcookies, expires, path, domain, secure);
    }

    static setAll(name, subcookies, expires, path, domain, secure) {
        let cookieText = encodeURIComponent(name) + "=",
            subcookieParts = new Array(),
            subName;
        for (subName in subcookies){
            if (subName.length > 0 && subcookies.hasOwnProperty(subName)){
                subcookieParts.push(
                    `${encodeURIComponent(subName)}=${encodeURIComponent(subcookies[subName])}'`);
            }
        }
    }
}
```

```

    if (cookieParts.length > 0) {
        cookieText += subcookieParts.join("&");

        if (expires instanceof Date) {
            cookieText += `; expires=${expires.toGMTString()}`;
        }

        if (path) {
            cookieText += `; path=${path}`;
        }

        if (domain) {
            cookieText += `; domain=${domain}`;
        }

        if (secure) {
            cookieText += "; secure";
        }
        else {
            cookieText += `; expires=${(new Date(0)).toGMTString()}`;
        }
        document.cookie = cookieText;
    }

    // more code here
};

```

The `set()` method accepts seven arguments: the cookie name, the subcookie name, the subcookie value, an optional `Date` object for the cookie expiration day/time, an optional cookie path, an optional cookie domain, and an optional Boolean `secure` flag. All of the optional arguments refer to the cookie itself and not to the subcookie. In order to store multiple subcookies in the same cookie, the path, domain, and `secure` flag must be the same; the expiration date refers to the entire cookie and can be set whenever an individual subcookie is written. Inside the method, the first step is to retrieve all of the subcookies for the given cookie name. The logical OR operator is used to set subcookies to a new object if `getAll()` returns `null`. After that, the subcookie value is set on the `subcookies` object and then passed into `setAll()`.

The `setAll()` method accepts six arguments: the cookie name, an object containing all of the subcookies, and then the rest of the optional arguments used in `set()`. This method iterates over the properties of the second argument using a `for-in` loop. To ensure that the appropriate data is saved, use the `hasOwnProperty()` method to ensure that only the instance properties are serialized into subcookies. Since it's possible to have a property name equal to the empty string, the length of the property name is also checked before being added to the result. Each subcookie name-value pair is added to the `subcookieParts` array so that they can later be easily joined with an ampersand using the `join()` method. The rest of the method is the same as `CookieUtil.set()`.

These methods can be used as follows:

```

// assume document.cookie=data=name=Nicholas&book=Professional%20JavaScript

// set two subcookies
SubCookieUtil.set("data", "name", "Nicholas");
SubCookieUtil.set("data", "book", "Professional JavaScript");

```

```
// set all subcookies with expiration date
SubCookieUtil.setAll("data", { name: "Nicholas", book: "Professional JavaScript" },
    new Date("January 1, 2010"));

// change the value of name and change expiration date for cookie
SubCookieUtil.set("data", "name", "Michael", new Date("February 1, 2010"));
```

The last group of subcookie methods has to do with removing subcookies. Regular cookies are removed by setting the expiration date to some time in the past, but subcookies cannot be removed as easily. In order to remove a subcookie, you need to retrieve all subcookies contained within the cookie, eliminate just the one that is meant to be removed, and then set the value of the cookie back with the remaining subcookie values. Consider the following:

```
class SubCookieUtil {
    // previous code here

    static unset(name, subName, path, domain, secure) {
        let subcookies = SubCookieUtil.getAll(name);
        if (subcookies){
            delete subcookies[subName]; // fix?
            SubCookieUtil.setAll(name, subcookies, null, path, domain, secure);
        }
    }

    static unsetAll(name, path, domain, secure) {
        SubCookieUtil.setAll(name, null, new Date(0), path, domain, secure);
    }
}
```

The two methods defined here serve two different purposes. The `unset()` method is used to remove a single subcookie from a cookie while leaving the rest intact; whereas the `unsetAll()` method is the equivalent of `CookieUtil.unset()`, which removes the entire cookie. As with `set()` and `setAll()`, the path, domain, and `secure` flag must match the options with which a cookie was created. These methods can be used as follows:

```
// just remove the "name" subcookie
SubCookieUtil.unset("data", "name");

// remove the entire cookie
SubCookieUtil.unsetAll("data");
```

If you are concerned about reaching the per-domain cookie limit in your work, subcookies are an attractive alternative. You will have to more closely monitor the size of your cookies to stay within the individual cookie size limit.

Cookie Considerations

There is also a type of cookie called *HTTP-only*. HTTP-only cookies can be set either from the browser or from the server but can be read only from the server because JavaScript cannot get the value of HTTP-only cookies.

Because all cookies are sent as request headers from the browser, storing a large amount of information in cookies can affect the overall performance of browser requests to a particular domain. The larger the cookie information, the longer it will take to complete the request to the server. Even

though the browser places size limits on cookies, it's a good idea to store as little information as possible in cookies, to avoid performance implications.

The restrictions on and nature of cookies make them less than ideal for storing large amounts of information, which is why other approaches have emerged.

NOTE *Avoid storing important or sensitive data in cookies. Cookie data is not stored in a secure environment, so any data contained within may be accessible by others. You should avoid storing data such as credit card numbers or personal addresses in cookies.*

WEB STORAGE

Web Storage was first described in the Web Applications 1.0 specification of the Web Hypertext Application Technical Working Group (WHAT-WG). The initial work from this specification eventually became part of HTML5 before being split into its own specification. Its intent is to overcome some of the limitations imposed by cookies when data is needed strictly on the client side, with no need to continuously send data back to the server.

The most modern edition of the Web Storage specification is its second edition. The two primary goals of the Web Storage specification are:

- To provide a way to store session data outside of cookies.
- To provide a mechanism for storing large amounts of data that persists across sessions.

The second edition of the Web Storage specification includes definitions for two objects: `localStorage`, the permanent storage mechanism, and `sessionStorage`, the session-scoped storage mechanism. Both of these browser storage APIs afford you two different ways of storing data in the browser that can survive a page reload. Both `localStorage` and `sessionStorage` are available as a property of window in all major vendor browser versions released since 2009.

NOTE `globalStorage` *was formerly part of the first edition of the Web Storage specification and has since been deprecated.*

The Storage Type

The `Storage` type is designed to hold name-value pairs up to a maximum size (determined by the browser). An instance of `Storage` acts like any other object and has the following additional methods:

- `clear()`—Removes all values; not implemented in Firefox.
- `getItem(name)`—Retrieves the value for the given name.

- `key(index)`—Retrieves the name of the value in the given numeric position.
- `removeItem(name)`—Removes the name-value pair identified by `name`.
- `setItem(name, value)`—Sets the value for the given name.

The `getItem()`, `removeItem()`, and `setItem()` methods can be called directly or indirectly by manipulating the `Storage` object. Since each item is stored on the object as a property, you can simply read values by accessing the property with dot or bracket notation, set the value by doing the same, or remove it by using the `delete` operator. Even so, it's generally recommended to use the methods instead of property access to ensure you don't end up overwriting one of the already available object members with a key.

You can determine how many name-value pairs are in a `Storage` object by using the `length` property. It's not possible to determine the size of all data in the object, although Internet Explorer 8 provides a `remainingSpace` property that retrieves the amount of space, in bytes, that is still available for storage.

NOTE *The `Storage` type is capable of storing only strings. Nonstring data is automatically converted into a string before being stored. Keep in mind that this conversion is not undone upon retrieval.*

The `sessionStorage` Object

The `sessionStorage` object stores data only for a session, meaning that the data is stored until the browser is closed. This is the equivalent of a session cookie that disappears when the browser is closed. Data stored on `sessionStorage` persists across page refreshes and may also be available if the browser crashes and is restarted, depending on the browser vendor. (Firefox and WebKit support this, but Internet Explorer does not.)

Because the `sessionStorage` object is tied to a server session, it isn't available when a file is run locally. Data stored on `sessionStorage` is accessible only from the page that initially placed the data onto the object, making it of limited use for multipage applications.

Because the `sessionStorage` object is an instance of `Storage`, you can assign data onto it either by using `setItem()` or by assigning a new property directly. Here's an example of each of these methods:

```
// store data using method
sessionStorage.setItem("name", "Nicholas");

// store data using property
sessionStorage.book = "Professional JavaScript";
```

All modern browsers implement storage writing as a blocking synchronous action, so data added to storage is committed right away. The API implementation might not write the value to disk right away (and prefers to initially use a different physical storage), but this difference is invisible at the JavaScript level, and any writes using some form of Web Storage can immediately be read.

Older Internet Explorer implementations write data asynchronously so there may be a lag between the time when data is assigned and the time that the data is written to disk. For small amounts of data, the difference is negligible. For large amounts of data, you'll notice that JavaScript in Internet Explorer resumes execution faster than in other browsers because it offloads the actual disk write process. You can force disk writing to occur in Internet Explorer 8 by using the `begin()` method before assigning any new data, and the `commit()` method after all assignments have been made. Consider the following example:

```
// IE8 only
sessionStorage.begin();
sessionStorage.name = "Nicholas";
sessionStorage.book = "Professional JavaScript";
sessionStorage.commit();
```

This code ensures that the values for "name" and "book" are written as soon as `commit()` is called. The call to `begin()` ensures that no disk writes will occur while the code is executed. For small amounts of data, this process isn't necessary; however, you may wish to consider this transactional approach for larger amounts of data such as documents.

When data exists on `sessionStorage`, it can be retrieved either by using `getItem()` or by accessing the property name directly. Here's an example of each of these methods:

```
// get data using method
let name = sessionStorage.getItem("name");

// get data using property
let book = sessionStorage.book;
```

You can iterate over the values in `sessionStorage` using a combination of the `length` property and `key()` method, as shown here:

```
for (let i = 0, len = sessionStorage.length; i < len; i++){
  let key = sessionStorage.key(i);
  let value = sessionStorage.getItem(key);
  alert(`${key}=${value}`);
}
```

The name-value pairs in `sessionStorage` can be accessed sequentially by first retrieving the name of the data in the given position via `key()` and then using that name to retrieve the value via `getItem()`.

It's also possible to iterate over the values in `sessionStorage` using a `for-in` loop:

```
for (let key in sessionStorage){
  let value = sessionStorage.getItem(key);
  alert(`${key}=${value}`);
}
```

Each time through the loop, `key` is filled with another name in `sessionStorage`; none of the built-in methods or the `length` property will be returned.

To remove data from `sessionStorage`, you can use either the `delete` operator on the object property or the `removeItem()` method. Here's an example of each of these methods:

```
// use delete to remove a value
delete sessionStorage.name;
```



```
// use method to remove a value
sessionStorage.removeItem("book");
```

The `sessionStorage` object should be used primarily for small pieces of data that are valid only for a session. If you need to persist data across sessions, then either `globalStorage` or `localStorage` is more appropriate.

The localStorage Object

The `localStorage` object superseded `globalStorage` in the revised HTML5 specification as a way to store persistent client-side data. In order to access the same `localStorage` object, pages must be served from the same domain (subdomains aren't valid), using the same protocol, and on the same port.

Because `localStorage` is an instance of `Storage`, it can be used in exactly the same manner as `sessionStorage`. Here are some examples:

```
// store data using method
localStorage.setItem("name", "Nicholas");

// store data using property
localStorage.book = "Professional JavaScript";

// get data using method
let name = localStorage.getItem("name");

// get data using property
let book = localStorage.book;
```

The difference between the two storage methods is that data stored in `localStorage` is persisted until it is specifically removed via JavaScript or the user clears the browser's cache. `localStorage` data will remain through page reloads, closing windows and tabs, and restarting the browser.

The storage Event

Whenever a change is made to a `Storage` object, the `storage` event is fired on the document. This occurs for every value set using either properties or `setItem()`, every value removal using either `delete` or `removeItem()`, and every call to `clear()`. The event object has the following four properties:

- `domain`—The domain for which the storage changed.
- `key`—The key that was set or removed.
- `newValue`—The value that the key was set to, or null if the key was removed.
- `oldValue`—The value prior to the key being changed.

You can listen for the `storage` event using the following code:

```
window.addEventListener("storage",
    (event) => alert('Storage changed for ${event.domain}'));
```

The `storage` event is fired for all changes to `sessionStorage` and `localStorage` but doesn't distinguish between them.

Limits and Restrictions

As with other client-side data storage solutions, Web Storage also has limitations. These limitations are browser-specific. Generally speaking, the size limit for client-side data is set on a per-origin (protocol, domain, and port) basis, so each origin has a fixed amount of space in which to store its data. Analyzing the origin of the page that is storing the data enforces this restriction.

Storage limits for `localStorage` and `sessionStorage` are inconsistent across browsers, but most will limit the per-origin storage to 5MB. A table containing up-to-date storage limits for each medium can be found at <https://www.html5rocks.com/en/tutorials/offline/quota-research/>.

For more information about Web Storage limits, please see the Web Storage Support Test at <http://dev-test.nemikor.com/web-storage/support-test/>.

INDEXEDDB

The Indexed Database API, *IndexedDB* for short, is a structured data store in the browser. IndexedDB came about as an alternative to the now-deprecated Web SQL Database API. The idea behind IndexedDB was to create an API that easily allowed the storing and retrieval of JavaScript objects while still allowing querying and searching.

IndexedDB is designed to be almost completely asynchronous. As a result, most operations are performed as requests that will execute later and produce either a successful result or an error. Nearly every IndexedDB operation requires you to attach `onerror` and `onsuccess` event handlers to determine the outcome.

As of 2017, the latest releases of most major vendor browsers (Chrome, Firefox, Opera, Safari) fully support IndexedDB. Internet Explorer 10/11 and Edge browsers partially support IndexedDB.

Databases

IndexedDB is a database similar to databases you've probably used before, such as MySQL or Web SQL Database. The big difference is that IndexedDB uses object stores instead of tables to keep track of data. An IndexedDB database is simply a collection of object stores grouped under a common name—a NoSQL-style implementation.

The first step to using a database is to open it using `indexedDB.open()` and passing in the name of the database to open. If a database with the given name already exists, then a request is made to open it; if the database doesn't exist, then a request is made to create and open it. The call to `indexedDB.open()` returns an instance of `IDBRequest` onto which you can attach `onerror` and `onsuccess` event handlers. Here's an example:

```
let db,
    request,
    version = 1;

request = indexedDB.open("admin", version);
request.onerror = (event) =>
  alert(`Failed to open: ${event.target.errorCode}`);
```

```
request.onsuccess = (event) => {
  db = event.target.result;
};
```

Formerly, IndexedDB used the `setVersion()` method to specify which version should be accessed. This method is now deprecated; as shown here, the version is now specified when opening the database. The version numbers will be converted to an `unsigned long long` number, so do not use decimal points; use whole integers instead.

In both event handlers, `event.target` points to `request`, so these may be used interchangeably. If the `onsuccess` event handler is called, then the database instance object (`IDBDatabase`) is available in `event.target.result` and stored in the `database` variable. From this point on, all requests to work with the database are made through the `database` object itself. If an error occurs, an error code stored in `event.target.errorCode` indicates the nature of the problem.

NOTE *Formerly, `IDBDatabaseException` was used to indicate the error that IndexedDB experienced. This has been replaced with standard `DOMExceptions`.*

Object Stores

Once you have established a connection to the database, the next step is to interact with object stores. If the database version doesn't match the one you expect then you likely will need to create an object store. Before creating an object store, however, it's important to think about the type of data you want to store.

Suppose that you'd like to store user records containing username, password, and so on. The object to hold a single record may look like this:

```
let user = {
  username: "007",
  firstName: "James",
  lastName: "Bond",
  password: "foo"
};
```

Looking at this object, you can easily see that an appropriate key for this object store is the `username` property. A username must be globally unique, and it's probably the way you'll be accessing data most of the time. This is important because you must specify a key when creating an object store.

The version of the database determines the database schema, which consists of the object stores in the database and the structures of those object stores. If the database doesn't yet exist, the `open()` operation creates it; then, an `upgradeneeded` event is fired. You can set a handler for this event and create the database schema in the handler. If the database exists but you are specifying an upgraded version number, an `upgradeneeded` event is fired immediately, allowing you to provide an updated schema in the event handler.

Here's how you would create an object store for these users:

```
request.onupgradeneeded = (event) => {
  const db = event.target.result;
```

```

// Delete the current objectStore if it exists. This is useful for testing,
// but this will wipe existing data each time this event handler executes.
if (db.objectStoreNames.contains("users")) {
  db.deleteObjectStore("users");
}

db.createObjectStore("users", { keyPath: "username" });
};

```

The `keyPath` property of the second argument indicates the property name of the stored objects that should be used as a key.

Transactions

Past the creation step of an object store, all further operations are done through *transactions*. A transaction is created using the `transaction()` method on the database object. Any time you want to read or change data, a transaction is used to group all changes together. In its simplest form, you create a new transaction as follows:

```
let transaction = db.transaction();
```

With no arguments specified, you have read-only access to all object stores in the database. A more targeted strategy is to specify one or more object store names that you want to access:

```
let transaction = db.transaction("users");
```

This ensures that only information about the `users` object store is loaded and available during the transaction. If you want access to more than one object store, the first argument can also be an array of strings:

```
let transaction = db.transaction(["users", "anotherStore"]);
```

As mentioned previously, each of these transactions accesses data in a read-only manner. To change that, you must pass in a second argument indicating the access mode. This argument should be one of three strings: `"readonly"`, `"readwrite"`, or `"versionchange"`. You can specify the second argument to `transaction()`:

```
let transaction = db.transaction("users", "readwrite");
```

This transaction is capable of both reading and writing into the `users` object store.

Once you have a reference to the transaction, you can access a particular object store using the `objectStore()` method and passing in the store name you want to work with. You can then use `add()` and `put()` as before, as well as `get()` to retrieve values, `delete()` to remove an object, and `clear()` to remove all objects. Both the `get()` and `delete()` methods accept an object key as their argument, and all five of these methods create a new request object. For example:

```

const transaction = db.transaction("users"),
      store = transaction.objectStore("users"),
      request = store.get("007");
request.onerror = (event) => alert("Did not get the object!");
request.onsuccess = (event) => alert(event.target.result.firstName);

```

Because any number of requests can be completed as part of a single transaction, the transaction object itself also has event handlers: `onerror` and `oncomplete`. These are used to provide transaction-level state information:

```
transaction.onerror = (event) => {
  // entire transaction was cancelled
};
transaction.oncomplete = (event) => {
  // entire transaction completed successfully
};
```

Keep in mind that the event object for `oncomplete` doesn't give you access to any data returned by `get()` requests, so you still need an `onsuccess` event handler for those types of requests.

Insertion

Because you now have a reference to the object store, it's possible to populate the object store with data using either `add()` or `put()`. Both of these methods accept a single argument, the object to store, and save the object into the object store. The difference between these two occurs only when an object with the same key already exists in the object store. In that case, `add()` will cause an error while `put()` will simply overwrite the object. More simply, think of `add()` as being used for inserting new values while `put()` is used for updating values. So to initialize an object store for the first time, you may want to do something like this:

```
// where users is an array of new users
for (let user of users) {
  store.add(user);
}
```

Each call to `add()` or `put()` creates a new update request for the object store. If you want verification that the request completed successfully, you can store the request object in a variable and assign `onerror` and `onsuccess` event handlers:

```
// where users is an array of new users
let request,
    requests = [];
for (let user of users) {
  request = store.add(user);
  request.onerror = () => {
    // handle error
  };
  request.onsuccess = () => {
    // handle success
  };
  requests.push(request);
}
```

Once the object store is created and filled with data, it's time to start querying.

Querying with Cursors

Transactions can be used directly to retrieve a single item with a known key. When you want to retrieve multiple items, you need to create a *cursor* within the transaction. A cursor is a pointer into a result set. Unlike traditional database queries, a cursor doesn't gather all of the result set up front. Instead, a cursor points to the first result and doesn't try to find the next until instructed to do so.

Cursors are created using the `openCursor()` method on an object store. As with other operations with IndexedDB, the return value of `openCursor()` is a request, so you must assign `onsuccess` and `onerror` event handlers. For example:

```
const transaction = db.transaction("users"),
      store = transaction.objectStore("users"),
      request = store.openCursor();
request.onsuccess = (event) => {
  // handle success
};
request.onfailure = (event) => {
  // handle failure
};
```

When the `onsuccess` event handler is called, the next item in the object store is accessible via `event.target.result`, which holds an instance of `IDBCursor` when there is a next item or `null` when there are no further items. The `IDBCursor` instance has several properties:

- `direction`—A numeric value indicating the direction the cursor should travel in and whether or not it should traverse all duplicate values. There are four possible string values: "next", "nextunique", "prev", and "prevunique".
- `key`—The key for the object.
- `value`—The actual object.
- `primaryKey`—The key being used by the cursor. Could be the object key or an index key (discussed later).

You can retrieve information about a single result using the following:

```
request.onsuccess = (event) => {
  const cursor = event.target.result;
  if (cursor) { // always check
    console.log(`Key: ${cursor.key}, Value: ${JSON.stringify(cursor.value)}`);
  }
};
```

Keep in mind that `cursor.value` in this example is an object, which is why it is JSON encoded before being displayed.

A cursor can be used to update an individual record. The `update()` method updates the current cursor value with the specified object. As with other such operations, the call to `update()` creates a new request so you need to assign `onsuccess` and `onerror` if you want to know the result:

```
request.onsuccess = (event) => {
  const cursor = event.target.result;
  let value,
      updateRequest;
```

```

if (cursor) { // always check
  if (cursor.key == "foo") {
    value = cursor.value; // get current value
    value.password = "magic!"; // update the password
    updateRequest = cursor.update(value); // request the update be saved
    updateRequest.onsuccess = () => {
      // handle success;
    };
    updateRequest.onfailure = () => {
      // handle failure
    };
  }
}
};

```

You can also delete the item at that position by calling `delete()`. As with `update()`, this also creates a request:

```

request.onsuccess = (event) => {
  const cursor = event.target.result;
  let value,
      deleteRequest;
  if (cursor) { // always check
    if (cursor.key == "foo") {
      deleteRequest = cursor.delete(); // request the value be deleted
      deleteRequest.onsuccess = () => {
        // handle success;
      };
      deleteRequest.onfailure = () => {
        // handle failure
      };
    }
  }
};

```

Both `update()` and `delete()` will throw errors if the transaction doesn't have permission to modify the object store.

Each cursor makes only one request by default. To make another request, you must call one of the following methods:

- `continue(key)`—Moves to the next item in the result set. The argument `key` is optional. When not specified, the cursor just moves to the next item; when provided, the cursor will move to the specified key.
- `advance(count)`—Moves the cursor ahead by `count` number of items.

Each of these methods causes the cursor to reuse the same request so the same `onsuccess` and `onfailure` event handlers are reused until no longer needed. For example, the following iterates over all items in an object store:

```

request.onsuccess = (event) => {
  const cursor = event.target.result;
  if (cursor) { // always check
    console.log(`Key: ${cursor.key}, Value: ${JSON.stringify(cursor.value)}`);
  }
};

```

```

        cursor.continue(); // go to the next one
    } else {
        console.log("Done!");
    }
};

```

The call to `continue()` triggers another request and `onsuccess` is called again. When there are no more items to iterate over, `onsuccess` is called one last time with `event.target.result` equal to `null`.

Key Ranges

Working with cursors may seem suboptimal given that you're limited in the ways data can be retrieved. *Key ranges* are used to make working with cursors a little more manageable. A key range is represented by an instance of `IDBKeyRange`. There are four different ways to specify key ranges. The first is to use the `only()` method and pass in the key you want to retrieve:

```
const onlyRange = IDBKeyRange.only("007");
```

This range ensures that only the value with a key of "007" will be retrieved. A cursor created using this range is similar to directly accessing an object store and calling `get("007")`.

The second type of range defines a lower bound for the result set. The lower bound indicates the item at which the cursor should start. For example, the following key range ensures the cursor starts at the key "007" and continues until the end:

```
// start at item "007", go to the end
const lowerRange = IDBKeyRange.lowerBound("007");
```

If you want to start at the item immediately following the value at "007", then you can pass in a second argument of `true`:

```
// start at item after "007", go to the end
const lowerRange = IDBKeyRange.lowerBound("007", true);
```

The third type of range is an upper bound, indicating the key you don't want to go past by using the `upperBound()` method. The following key ensures that the cursor starts at the beginning and stops when it gets to the value with key "ace":

```
// start at beginning, go to "ace"
const upperRange = IDBKeyRange.upperBound("ace");
```

If you don't want to include the given key, then pass in `true` as the second argument:

```
// start at beginning, go to the item just before "ace"
const upperRange = IDBKeyRange.upperBound("ace", true);
```

To specify both a lower and an upper bound, use the `bound()` method. This method accepts four arguments, the lower bound key, the upper bound key, an optional Boolean indicating to skip the lower bound, and an optional Boolean indicating to skip the upper bound. Here are some examples:

```
// start at "007", go to "ace"
const boundRange = IDBKeyRange.bound("007", "ace");
// start at item after "007", go to "ace"
const boundRange = IDBKeyRange.bound("007", "ace", true);
// start at item after "007", go to item before "ace"

```



```
const boundRange = IDBKeyRange.bound("007", "ace", true, true);
// start at "007", go to item before "ace"
const boundRange = IDBKeyRange.bound("007", "ace", false, true);
```

Once you have defined a range, pass it into the `openCursor()` method and you'll create a cursor that stays within the constraints:

```
const store = db.transaction("users").objectStore("users"),
      range = IDBKeyRange.bound("007", "ace");
const request = store.openCursor(range);
request.onsuccess = function(event) {
  const cursor = event.target.result;
  if (cursor) { // always check
    console.log(`Key: ${cursor.key}, Value: ${JSON.stringify(cursor.value)}`);
    cursor.continue(); // go to the next one
  } else {
    console.log("Done!");
  }
};
```

This example outputs only the values between keys "007" and "ace", which are fewer than the previous section's example.

Setting Cursor Direction

There are actually two arguments to `openCursor()`. The first is an instance of `IDBKeyRange` and the second is a string indicating the direction. Typically, cursors start at the first item in the object store and progress toward the last with each call to `continue()` or `advance()`. These cursors have the default direction value of "next". If there are duplicates in the object store, you may want to have a cursor that skips over the duplicates. You can do so by passing "nextunique" into `openCursor()` as the second argument:

```
const transaction = db.transaction("users"),
      store = transaction.objectStore("users"),
      request = store.openCursor(null, "nextunique");
```

Note that the first argument to `openCursor()` is null, which indicates that the default key range of all values should be used. This cursor will iterate through the items in the object store starting from the first item and moving toward the last while skipping any duplicates.

You can also create a cursor that moves backward through the object store, starting at the last item and moving toward the first by passing in either "prev" or "prevunique" (the latter, of course, to avoid duplicates). For example:

```
const transaction = db.transaction("users"),
      store = transaction.objectStore("users"),
      request = store.openCursor(null, "prevunique");
```

When you open a cursor using "prev" or "prevunique", each call to `continue()` or `advance()` moves the cursor backward through the object store instead of forward.

Indexes

For some data sets, you may want to specify more than one key for an object store. For example, if you're tracking users by both a user ID and a username, you may want to access records using either piece of data. To do so, you would likely consider the user ID as the primary key and create an index on the username.

To create a new index, first retrieve a reference to the object store and then call `createIndex()`, as in this example:

```
const transaction = db.transaction("users"),
  store = transaction.objectStore("users"),
  index = store.createIndex("username", "username", { unique: true });
```

The first argument to `createIndex()` is the name of the index, the second is the name of the property to index, and third is an options object containing the key `unique`. This option should always be specified so as to indicate whether or not the key is unique across all records. Because `username` may not be duplicated, this index is unique.

The returned value from `createIndex()` is an instance of `IDBIndex`. You can also retrieve the same instance via the `index()` method on an object store. For example, to use an already existing index named "username", the code would be:

```
const transaction = db.transaction("users"),
  store = transaction.objectStore("users"),
  index = store.index("username");
```

An index acts a lot like an object store. You can create a new cursor on the index using the `openCursor()` method, which works exactly the same as `openCursor()` on an object store except that the `result.key` property is filled in with the index key instead of the primary key. Here's an example:

```
const transaction = db.transaction("users"),
  store = transaction.objectStore("users"),
  index = store.index("username"),
  request = index.openCursor();
request.onsuccess = (event) => {
  // handle success
};
```

An index can also create a special cursor that returns just the primary key for each record using the `openKeyCursor()` method, which accepts the same arguments as `openCursor()`. The big difference is that `event.result.key` is the index key and `event.result.value` is the primary key instead of the entire record.

```
const transaction = db.transaction("users"),
  store = transaction.objectStore("users"),
  index = store.index("username"),
  request = index.openKeyCursor();
request.onsuccess = (event) => {
  // handle success
  // event.result.key is the index key, event.result.value is the primary key
};
```

You can also retrieve a single value from an index by using `get()` and passing in the index key, which creates a new request:

```
const transaction = db.transaction("users"),
  store = transaction.objectStore("users"),
  index = store.index("username"),
  request = index.get("007");
request.onsuccess = (event) => {
  // handle success
};
request.onfailure = (event) => {
  // handle failure
};
```

To retrieve just the primary key for a given index key, use the `getKey()` method. This also creates a new request but `result.value` is equal to the primary key value rather than the entire record:

```
const transaction = db.transaction("users"),
  store = transaction.objectStore("users"),
  index = store.index("username"),
  request = index.getKey("007");
request.onsuccess = (event) => {
  // handle success
  // event.result.key is the index key, event.result.value is the primary key
};
```

In the `onsuccess` event handler in this example, `event.result.value` would be the user ID.

At any point in time, you can retrieve information about the index by using properties on the `IDBIndex` object:

- ▶ `name`—The name of the index.
- ▶ `keyPath`—The property path that was passed into `createIndex()`.
- ▶ `objectStore`—The object store that this index works on.
- ▶ `unique`—A Boolean indicating if the index key is unique.

The object store itself also tracks the indexes by name in the `indexNames` property. This makes it easy to figure out which indexes already exist on an object using the following code:

```
const transaction = db.transaction("users"),
  store = transaction.objectStore("users"),
  indexNames = store.indexNames
for (let indexName in indexNames) {
  const index = store.index(indexName);
  console.log(`Index name: ${index.name}
              KeyPath: ${index.keyPath}
              Unique: ${index.unique}`);
}
```

This code iterates over each index and outputs its information to the console.

An index can be deleted by calling the `deleteIndex()` method on an object store and passing in the name of the index:

```
const transaction = db.transaction("users"),
      store = transaction.objectStore("users"),
      store.deleteIndex("username");
```

Because deleting an index doesn't touch the data in the object store, the operation happens without any callbacks.

Concurrency Issues

While IndexedDB is an asynchronous API inside of a web page, there are still concurrency issues. If the same web page is open in two different browser tabs at the same time, it's possible that one may attempt to upgrade the database before the other is ready. The problematic operation is in setting the database to a new version, and so version changes can be completed only when there is just one tab in the browser using the database.

When you first open a database, it's important to assign an `onversionchange` event handler. This callback is executed when another tab from the same origin opens the DB to a new version. The best response to this event is to immediately close the database so that the version upgrade can be completed. For example:

```
let request, database;

request = indexedDB.open("admin", 1);
request.onsuccess = (event) => {
  database = event.target.result;
  database.onversionchange = () => database.close();
};
```

You should assign `onversionchange` after every successful opening of a database. Remember, `onversionchange` will have been called in the other tab(s) as well.

By always assigning these event handlers, you will ensure your web application will be able to better handle concurrency issues related to IndexedDB.

Limits and Restrictions

Many of the restrictions on IndexedDB are exactly the same as those for Web Storage. First, IndexedDB databases are tied to the origin (protocol, domain, and port) of the page, so the information cannot be shared across domains. This means there is a completely separate data store for `www.wrox.com` as for `p2p.wrox.com`.

Second, there is a limit to the amount of data that can be stored per origin. The current limit in Firefox is 50MB per origin while Chrome has a limit of 5MB. Firefox for mobile has a limit of 5MB and will ask the user for permission to store more than that if the quota is exceeded.

Firefox imposes an extra limitation that local files cannot access IndexedDB databases at all. Chrome doesn't have this restriction. When running the examples from this book locally, be sure to use Chrome.

SUMMARY

Web Storage defines two objects to save data: `sessionStorage` and `localStorage`. The former is used strictly to save data within a browser session because the data is removed once the browser is closed. The latter is used to persist data across sessions.

IndexedDB is a structured data storage mechanism similar to an SQL database. Instead of storing data in tables, data is stored in object stores. Object stores are created by defining a key and then adding data. Cursors are used to query object stores for particular pieces of data, and indexes may be created for faster lookups on particular properties.

With all of these options available, it's possible to store a significant amount of data on the client machine using JavaScript. You should use care not to store sensitive information because the data cache isn't encrypted.

26

Modules

WHAT'S IN THIS CHAPTER?

- ▶ Understanding the module pattern
- ▶ Improvising module systems
- ▶ Working with pre-ES6 module loaders
- ▶ Working with ES6 modules

WROX.COM DOWNLOADS FOR THIS CHAPTER

Please note that all the code examples for this chapter are available as a part of this chapter's code download on the book's website at www.wrox.com/go/projavascript4e on the Download Code tab.

Writing modern JavaScript essentially guarantees that you will be working with large codebases and using third-party resources. A consequence of these is that you will end up using code broken into different parts and connecting them together in some way.

Prior to the ECMAScript 6 module specification, there was a dire need for module-like behavior even though browsers did not natively support it. ECMAScript did not support modules in any way, so libraries and codebases that wanted to use the module pattern were required to cleverly use JavaScript constructs and lexical features to “fake” module-like behavior.

Because JavaScript is an asynchronously loaded interpreted language, the module implementations that emerged and gained widespread use took on a handful of different forms. These different forms took their shape in order to accomplish different results, but ultimately, they were all implementations of the canonical module pattern.

UNDERSTANDING THE MODULE PATTERN

Splitting code into independent pieces and connecting those pieces together can be robustly implemented with the module pattern. The central ideas for this pattern are simple: break logic into pieces that are totally encapsulated from the rest of the code, allow each piece to explicitly define what parts of itself are exposed to external pieces, and allow each piece to explicitly define what external pieces it needs to execute. There are various implementations and features that complicate these concepts, but these fundamental ideas are the foundation for all module systems in JavaScript.

Module Identifiers

Common to all module systems is the concept of module identifiers. Module systems are essentially key-value entities, where each module has an identifier that can be used to reference it. This token will sometimes be a string in cases where the module system is emulated, or it might be an actual path to a module file in cases where the module system is natively implemented.

Some module systems will allow you to explicitly declare the identity of a module, and some module systems will implicitly use the filename as the module identity token. In either case, a well-formed module system will have no module identity collisions, and any module in the system should be able to reference a different module in the system with no ambiguity.

Exactly how a module identifier is resolved to an actual module will be subject to the identifier implementation in any given module system. Native browser module identifiers must provide a path to an actual JavaScript file. In addition to file paths, NodeJS will perform a search for module matches inside the `node_modules` directory, and can also match an identifier to a directory containing `index.js`.

Module Dependencies

The real meat of module systems comes into play when considering how to manage dependencies. A module specifying a dependency is entering into a contract with the surrounding environment. The local module declares to the module system a list of external modules—“dependencies”—that it knows exist and are required for the local module to function properly. The module system inspects the dependencies and in turn guarantees that these modules will be loaded and initialized by the time the local module executes.

Each module also is associated with some unique token that can be used to retrieve the module. Frequently, this is a path to the JavaScript file, but in some module systems this can also be a namespace path string declared within the module itself.

Module Loading

The concept of “loading” a module is borne out of the requirements of a dependency contract. When an external module is specified as a dependency, the local module expects that when it is executed, the dependencies will be ready and initialized.

In the context of browsers, loading a module has several components. Loading a module involves executing the code inside it, but this cannot begin until all the dependencies are loaded and executed first. A module dependency, if it is code that has not yet been sent to the browser, must be requested and delivered over the network. Once the code payload is received by the browser, the browser must determine if the newly loaded external module has its own dependencies, and it will recursively evaluate those dependencies and load them in turn until all dependent modules are loaded. Only once the entire dependency graph is loaded can the entry module begin to execute.

Entry Points

A network of modules that depend upon each other must specify a single module as the “entry point,” where the path of execution will begin. This should make good sense, as the JavaScript execution environment is serially executed and single threaded—so the code must start somewhere. This entry point module will likely have module dependencies, and some of those dependencies will in turn have dependencies. The net effect of this is that all the modules of a modular JavaScript application will form a dependency graph.

Dependencies between modules in an application can be represented as a directed graph. Suppose the dependency graph shown in Figure 26-1 represents an imaginary application:

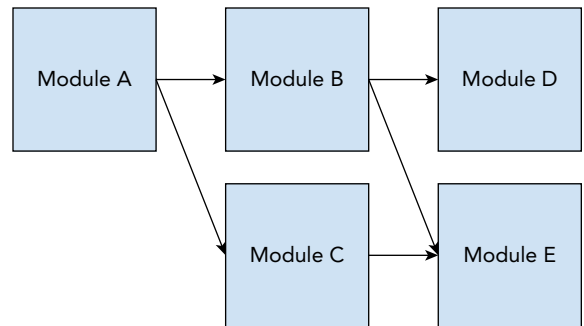

FIGURE 26-1:

Arrows represent the flow of module dependencies: Module A depends on Module B and Module C, Module B depends on Module D and Module E, and so on. Because a module cannot be loaded until its dependencies are loaded, it follows that Module A, the entry point in this imaginary application, must be executed only after the rest of the application loads.

In JavaScript, the concept of “loading” can take a number of different forms. Because modules are implemented as a file containing JavaScript code that will immediately execute, it is possible to request the individual scripts in an order that will satisfy the dependency graph. For the preceding application, the following script order would satisfy the dependency graph:

```

<script src="moduleE.js"></script>
<script src="moduleD.js"></script>
<script src="moduleC.js"></script>
<script src="moduleB.js"></script>
<script src="moduleA.js"></script>
  
```

Module loading is “blocking,” meaning further execution cannot continue until an operation finishes. Each module progressively loads after its script payload is delivered to the browser, with all its dependencies already loaded and initialized. This strategy has a number of performance and complexity implications, however: loading five JavaScript files sequentially to do the work of one application is not ideal, and managing the correct load order is not an easy task to do by hand.

Asynchronous Dependencies

Because JavaScript is an asynchronous language, it can also be useful to load modules on demand by allowing JavaScript code to instruct the module system to load a new module, and provide the module to a callback once it is ready. At the code level, pseudocode for this might appear as follows:

```
// moduleA definition
load('moduleB').then(function(moduleB) {
  moduleB.doStuff();
});
```

Module A's code is using the `moduleB` token to request that the module system load Module B, and invoke the callback with Module B provided as a parameter. Module B might have already been loaded, or it might have to be freshly requested and initialized, but this code does not care—those responsibilities are delegated to the module loader.

If you were to rework the previous application to use only programmatic module loading, you would only need to use a single `<script>` tag for Module A to load, and Module A would request module files as needed—no generating an ordered list of dependencies required. This has a number of benefits, one of which is performance, as only one file synchronously loading is required on pageload.

It would also be possible to keep these scripts separated, apply a `defer` or `async` attribute to the `<script>` tags, and include logic that can discern when an asynchronously script is loaded and initialized. This behavior would emulate what is implemented in the ES6 module specification, which is covered later in the chapter.

Programmatic Dependencies

Some module systems will require you to specify all dependencies at the beginning of a module, but some module systems will allow you to dynamically add dependencies inside the program structure. This is distinct from regular dependencies listed at the beginning of a module, all of which are required to load before a module can begin to execute.

The following is an example of programmatic dependency loading.

```
if (loadCondition) {
  require('./moduleA');
}
```

Inside this module, it is determined only at runtime if `moduleA` is loaded. The loading of `moduleA` might be blocking, or it might yield execution and only continue once the module is loaded. Either way, execution inside this module cannot continue until `moduleA` is loaded because the assumption is that `moduleA`'s presence is critical for subsequent module behavior.

Programmatic dependencies allow for more complex dependency utilization, but at a cost—it makes static analysis of a module more difficult.

Static Analysis

The JavaScript that you build into modules and deliver to the browser is often subject to static analysis, where tools will inspect the structure of your code and reason about how it will behave without performing program execution. A module system that is friendly to static analysis will allow module

bundling systems to have an easier time when figuring out how to combine your code into fewer files. It will also offer you the ability to perform intelligent autocomplete inside a smart editor.

More complicated module behavior, such as programmatic dependencies, will make static analysis more difficult. Different module systems and module loaders will offer varying levels of complexity. With respect to a module's dependencies, additional complexity will make it more difficult for tooling to predict exactly which dependencies a module will need when it executes.

Circular Dependencies

It is nearly impossible to architect a JavaScript application that is free of dependency cycles, and therefore all module systems including CommonJS, AMD, and ES6—support cyclical dependencies. In an application with dependency cycles, the order in which modules are loaded may not be what you expect. However, if you have properly structured your modules in a way that has no side-effects, the load order should not be a detriment to your overall application.

In the following module (which uses module-agnostic pseudocode), any of the modules could be used as the entry point module even though there are cycles in the dependency graph:

```
require('./moduleD');
require('./moduleB');

console.log('moduleA');
require('./moduleA');
require('./moduleC');

console.log('moduleB');
require('./moduleB');
require('./moduleD');

console.log('moduleC');

require('./moduleA');
require('./moduleC');

console.log('moduleD');
```

Changing the module that is used as the main module will change the dependency load order. If `moduleA` were to be loaded first, it would print the following, which is indicative of the absolute order of when a module load completes:

```
moduleB
moduleC
moduleD
moduleA
```

The load order can be visualized with the dependency graph in Figure 26-2, where the loader will perform a depth-first load of the dependencies:

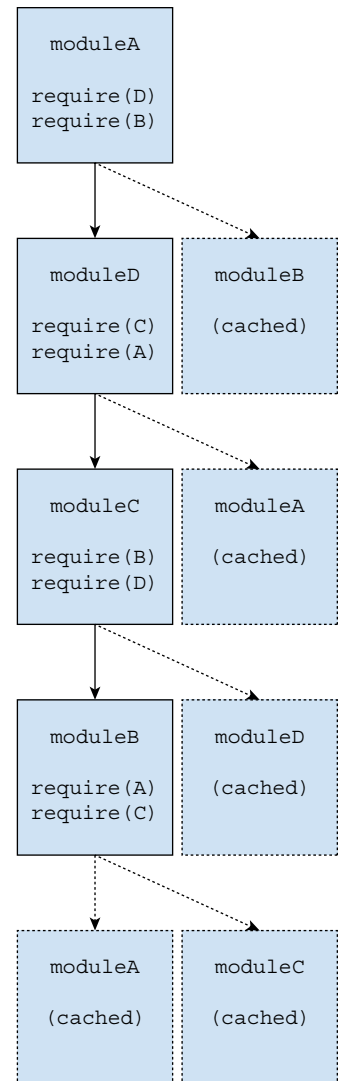

FIGURE 26-2:

If, instead, `moduleC` were to be loaded first, it would print the following, which is indicative of the absolute order of module loads:

```
moduleD
moduleA
moduleB
moduleC
```

The load order can be visualized with the dependency graph in Figure 26-3, where the loader will perform a depth-first load of the dependencies:

IMPROVISING MODULE SYSTEMS

In order to offer the encapsulation required by the module pattern, pre-ES6 modules sometimes used function scope and immediately invoked function expressions (IIFEs) to wrap the module definition in an anonymous closure. The module definition is executed immediately, as shown here:

```
(function() {
  // private Foo module code
  console.log('bar');
})();

// 'bar'
```

When the return value of this module was assigned to a variable, this effectively created a namespace for the module:

```
var Foo = (function() {
  console.log('bar');
})();

'bar'
```

In order to expose a public API, the module IIFE would return an object whose properties would be the public members inside the module namespace:

```
var Foo = (function() {
  return {
    bar: 'baz',
    baz: function() {
      console.log(this.bar);
    }
  };
})();

console.log(Foo.bar); // 'baz'
Foo.baz();           // 'baz'
```

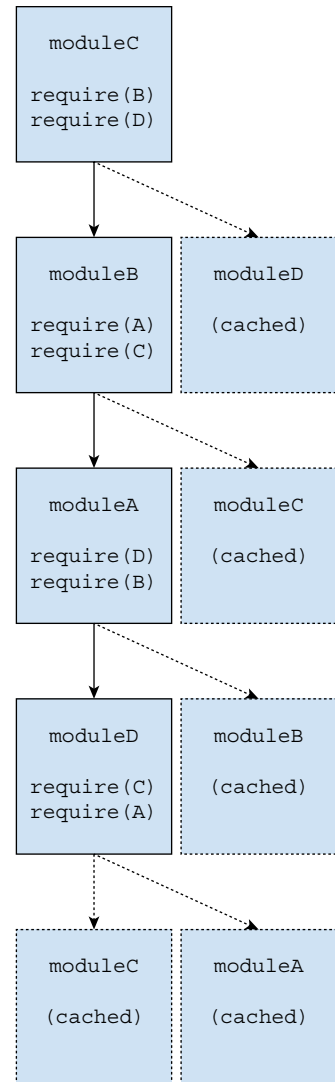

FIGURE 26-3:

A similar pattern to the previous one, termed the “Revealing module pattern,” only returns an object whose properties are references to private data and members:

```
var Foo = (function() {
  var bar = 'baz';
  var baz = function() {
    console.log(bar);
  };

  return {
    bar: bar,
    baz: baz
  };
})();

console.log(Foo.bar); // 'baz'
Foo.baz();           // 'baz'
```

It’s also possible to define modules within modules, which can be useful for namespace nesting purposes:

```
var Foo = (function() {
  return {
    bar: 'baz'
  };
})();

Foo.baz = (function() {
  return {
    qux: function() {
      console.log('baz');
    }
  };
})();

console.log(Foo.bar); // 'baz'
Foo.baz.qux();      // 'baz'
```

For the module to use external values properly, they can be passed in as parameters to the IIFE:

```
var globalBar = 'baz';

var Foo = (function(bar) {
  return {
    bar: bar,
    baz: function() {
      console.log(bar);
    }
  };
})(globalBar);

console.log(Foo.bar); // 'baz'
Foo.baz();           // 'baz'
```

Because the module implementations here are simply creating an instance of JavaScript object, it's entirely possible to augment the module after its definition:

```
// Original Foo
var Foo = (function(bar) {
  var bar = 'baz';

  return {
    bar: bar
  };
})();

// Augment Foo
var Foo = (function(FooModule) {
  FooModule.baz = function() {
    console.log(FooModule.bar);
  }

  return FooModule;
})(Foo);

console.log(Foo.bar); // 'baz'
Foo.baz();           // 'baz'
```

It can also be useful to configure the module augmentation to perform the augmentation whether the module is present or not:

```
// Augment Foo to add alert method
var Foo = (function(FooModule) {
  FooModule.baz = function() {
    console.log(FooModule.bar);
  }

  return FooModule;
})(Foo || {});

// Augment Foo to add data
var Foo = (function(FooModule) {
  FooModule.bar = 'baz';

  return FooModule;
})(Foo || {});

console.log(Foo.bar); // 'baz'
Foo.baz();           // 'baz'
```

As you might suspect, designing your own module system is an interesting exercise, but is not recommended for actual use, as the result is brittle. The preceding examples do not have a good way of programmatically loading dependencies other than using the maligned `eval`. Dependencies must be managed and ordered manually. Asynchronous loading and circular dependencies are extremely difficult to add. Lastly, performing static analysis on such a system would be quite difficult.

WORKING WITH PRE-ES6 MODULE LOADERS

Prior to the introduction of native ES6 module support, JavaScript codebases using modules essentially wanted to use a language feature that was not available by default. Therefore, codebases would be written in a module syntax that conformed to a certain specification, and separate module tooling would serve to bridge the gap between the module syntax and the JavaScript runtime. The module syntax and bridging took a number of different forms, usually either a supplementary library in the browser or preprocessing at build time.

CommonJS

The CommonJS specification outlines a convention for module definition that uses synchronous declarative dependencies. This specification is primarily intended for module organization on the server, but it can also be used to define dependencies for modules that will be used in the browser. CommonJS module syntax will not work natively in the browser.

NOTE *Often, NodeJS and CommonJS will be described as using the same style of module systems, and this is not entirely true. NodeJS uses a slightly modified version of CommonJS, which is appropriate in a server environment because it does not need to deal with the issue of network latency. For consistency, this section will use the NodeJS-flavored module definition syntax.*

A CommonJS module definition will specify its dependencies using `require()`, and it will define its public API using an `exports` object. A simple module definition might appear as follows:

```
var moduleB = require('./moduleB');

module.exports = {
  stuff: moduleB.doStuff();
};
```

`moduleA` specifies its dependency on `moduleB` by using a relative path to the module definition. What counts as a “module definition,” and how a string references that module, is entirely up to the module system’s implementation. In NodeJS for example, a module identifier might point to a single file, or it might point to a directory with an `index.js` file inside.

Requiring a module will load it, and assignment of the module to a variable is extremely common, but assignment to a variable is not required. Invoking `require()` means the module will load all the same.

```
console.log('moduleA');
require('./moduleA'); // "moduleA"
```

Modules are always singletons, irrespective of how many times a module is referenced inside `require()`. In the following example, `moduleA` will only ever be printed once because `moduleA` is only ever loaded a single time—even though it is required multiple times.

```
console.log('moduleA');
var a1 = require('./moduleA');
var a2 = require('./moduleA');

console.log(a1 === a2); // true
```

Modules are cached after the first time they are loaded; subsequent attempts to load a module will retrieve the cached module. Module load order is determined by the dependency graph.

```
console.log('moduleA');
require('./moduleA');
require('./moduleB'); // "moduleA"
require('./moduleA');
```

In CommonJS, module loading is a synchronous operation performed by the module system, so `require()` can be programmatically invoked inline in a module, as well as conditionally.

```
console.log('moduleA');
if (loadCondition) {
  require('./moduleA');
}
```

Here, `moduleA` will load only if `loadCondition` evaluates to `true`. The load is synchronous, so any code that precedes the `if()` block will execute before `moduleA` loads, and any code that follows the `if()` block will execute after `moduleA` loads. All the same load order rules apply, so if `moduleA` had been loaded previously elsewhere in the module graph, this conditional `require()` would only serve to allow you to use the `moduleA` namespace.

In these examples, the module system is implemented inside NodeJS, so `./moduleB` is a relative path to a module target in the same directory as this module. NodeJS will use the module identifier string in the `require()` call to resolve the module reference dependency. NodeJS can use absolute or relative paths to modules, or it can also use module identifiers for dependencies installed in the `node_modules` directory. These details aren't germane to the subject matter of this book, but it's important to know that the module's string reference might be differently implemented inside different CommonJS implementations. However, common to all CommonJS-style implementations is that modules will not specify their identifier; it is derived from their location in the module file hierarchy.

The path to the module definition might reference a directory, or it might be a single JavaScript file—either way, this local module is unconcerned with the module implementation, and Module B is loaded into a local variable. Module A in turn defines its public interface, the `foo` property, on the `module.exports` object.

If another module wanted to use this interface, it could import the module as follows:

```
var moduleA = require('./moduleA');

console.log(moduleA.stuff);
```

Note here that this module does not export anything. Even though it has no public interface, if the module were required in an application, it would still execute the module body on load.

The exports object is extremely flexible, and can take on multiple forms. If you are looking to export only a single entity, you are able to perform a direct assignment to `module.exports`:

```
module.exports = 'foo';
```

This way, the entire module interface is a string, which can be used as follows:

```
var moduleA = require('./moduleB');

console.log(moduleB); // 'foo'
```

It is also very common to bundle multiple values into exports, which can either be done with an object literal assignment or a one-off property assignment:

```
// Equivalent:

module.exports = {
  a: 'A',
  b: 'B'
};

module.exports.a = 'A';
module.exports.b = 'B';
```

One of the primary uses of modules is to house class definitions (shown here using ES6-style class definition, but ES5-style class definition is also compatible):

```
class A {}

module.exports = A;
var A = require('./moduleA');

var a = new A();
```

It is also possible to assign an instance of a class as the exported value:

```
class A {}

module.exports = new A();
```

Furthermore, CommonJS supports programmatic dependencies:

```
if (condition) {
  var A = require('./moduleA');
}
```

CommonJS relies on several globals such as `require` and `module.exports` to work. For CommonJS modules to be usable in the browser, there needs to be some sort of bridge between its non-native module syntax. There also needs to be some sort of barrier between the module-level code and the browser runtime, as CommonJS code executed without encapsulation will declare global variables in the browser—behavior that is undesirable in the module pattern.

A common solution is to bundle the module files together ahead of time, convert the globals to native JavaScript constructs, encapsulate the module code inside function closures, and serve a single file. Comprehension of the dependency graph is required to bundle the modules in the correct order.

Asynchronous Module Definition

Whereas CommonJS is targeted at a server execution model—where there is no penalty for loading everything into memory at once—the Asynchronous Module Definition (AMD) system of module definition is specifically targeted at a browser execution model, where there *are* penalties from increased network latency. The general strategy of AMD is for modules to declare their dependencies, and the module system running in the browser will fetch the dependencies on demand and execute the module that depends on them once they have all loaded.

The core of the AMD module implementation is a function wrapper around the module definition. This prevents the declaration of global variables and allows for the loader library to control when to load the module. The function wrapper also allows for superior portability of module code because all the module code inside the function wrapper uses native JavaScript constructs. This function wrapper is an argument to the `define` global, which is defined by the AMD loader library implementation.

An AMD module can specify its dependencies with string identifiers, and the AMD loader will call the module factory function once all the dependent modules have loaded. Unlike CommonJS, AMD allows you to optionally specify the string identifier for your module.

```
// Definition for a module with id 'moduleA'. moduleA depends on moduleB,
// which will be loaded asynchronously.
define('moduleA', ['moduleB'], function(moduleB) {
  return {
    stuff: moduleB.doStuff();
  };
});
```

AMD also supports the `require` and `exports` objects, which allow for construction of CommonJS-style modules inside an AMD module factory function. These are required in the same way as modules, but the AMD loader will recognize them as native AMD constructs rather than module definitions:

```
define('moduleA', ['require', 'exports'], function(require, exports) {
  var moduleB = require('moduleB');

  exports.stuff = moduleB.doStuff();
});
```

Programmatic dependencies are supported using this style:

```
define('moduleA', ['require'], function(require) {
  if (condition) {
    var moduleB = require('moduleB');
  }
});
```

Universal Module Definition

In an attempt to unify the CommonJS and AMD ecosystems, the Universal Module Definition (UMD) convention was introduced to create module code that could be used by both systems. Essentially, the pattern defines modules in a way that detects which module system is being used upon startup, configures it as appropriate, and wraps the whole thing in an immediately invoked function expression. It is an imperfect combination, but for the purposes of combining the two ecosystems it is suitable in a surprisingly large number of scenarios.

An example module with a single dependency (based on the UMD repository on GitHub) is as follows:

```
(function (root, factory) {
  if (typeof define === 'function' && define.amd) {
    // AMD. Register as an anonymous module.
    define(['moduleB'], factory);
  } else if (typeof module === 'object' && module.exports) {
    // Node. Does not work with strict CommonJS, but
    // only CommonJS-like environments that support module.exports,
    // like Node.
    module.exports = factory(require(' moduleB '));
  } else {
    // Browser globals (root is window)
    root.returnExports = factory(root, moduleB);
  }
})(this, function (moduleB) {
  //use moduleB in some fashion.

  // Just return a value to define the module export.
  // This example returns an object, but the module
  // can return a function as the exported value.
  return {};
});
```

There are variations on this pattern that enable support for strict CommonJS and browser globals. You should never be expected to be authoring this exact wrapper by hand—it should be automatically generated by a build tool. Your goal is to be concerned with the content of the modules, not the boilerplate that connects each of them.

Module Loader Deprecation

Ultimately, the patterns shown in this section will become increasingly obsolete as support broadens for the ECMAScript 6 module specification. That being so, it still is quite useful to know what the ES6 module specification grew out of in order to learn why design decisions were chosen. The intense conflict between CommonJS and AMD cultivated the ECMAScript 6 module specification that we now enjoy.

WORKING WITH ES6 MODULES

One of ECMAScript 6's most significant introductions was a specification for modules. The specification in many ways is simpler than its predecessor module loaders, and native browser support means that loader libraries and other preprocessing is not necessary. In many ways, ES6 module system unifies the best features of AMD and CommonJS into a single specification.

Module Tagging and Definition

ECMAScript 6 modules exist as a monolithic chunk of JavaScript. A script tag with `type="module"` will signal to the browser that the associated code should be executed as a module, as opposed to execution as a traditional script. Modules can be defined inline or in an external file:

```
<script type="module">
  // module code
</script>

<script type="module" src="path/to/myModule.js"></script>
```

Even though they are handled in a different way than a conventionally loaded JavaScript file, JavaScript module files do not have a special content type.

Unlike their traditional script counterparts, all modules will execute in the same order that a `<script defer>` would execute. Downloading a module file begins immediately after the `<script type="module">` tag is parsed, but execution is delayed until the document is completely parsed. This applies to both inline modules and modules defined in external files. The order in which `<script type="module">` code appears on the page is the order in which it will execute. As is the case with `<script defer>`, changing the location of the module tags—either in `<head>` or `<body>`—will only control when the files load, not when the modules are loaded.

The following is the order of execution for an inline module:

```
<!-- Executes 2nd -->
<script type="module"></script>

<!-- Executes 3rd -->
<script type="module"></script>

<!-- Executes 1st -->
<script></script>
```

Alternately, this can be reworked with an external JS module definition:

```
<!-- Executes 2nd -->
<script type="module" src="module.js"></script>

<!-- Executes 3rd -->
<script type="module" src="module.js"></script>

<!-- Executes 1st -->
<script><script>
```

It is also possible to add an `async` attribute to module tags. The effect of this is twofold: the order of module execution no longer is bound to the order of script tags on the page, and the module will not

wait for the document to be finished parsing before beginning execution. The entry module must still wait for its dependencies to load.

ES6 modules associated with a `<script type="module">` tag are considered to be the entry module for a module graph. There are no restrictions as to how many entry modules there can be on a page, and there is no limit to overlap of modules. No matter how many times a module is loaded in a page, irrespective of how that load occurs, it will only ever load a single time, as demonstrated here:

```
<!-- moduleA will only load a single time on this page -->

<script type="module">
  import './moduleA.js'
</script>
<script type="module">
  import './moduleA.js'
</script>
<script type="module" src="./moduleA.js"></script>
<script type="module" src="./moduleA.js"></script>
```

Modules defined inline cannot be loaded into other modules using `import`. Only modules loaded from an external file can be loaded using `import`. Therefore, inline modules are only useful as an entry point module.

Module Loading

ECMAScript 6 modules are unique in their ability to be loaded both natively by the browser as well as in conjunction with third-party loaders and build tools. Some browsers still do not natively support ES6 modules, so third-party tooling may be required. In many cases, third-party tooling may, in fact, be more desirable.

A browser that offers full ECMAScript 6 module support will be able to load the entire dependency graph from a top-level module, and it will do so asynchronously. The browser will interpret the entry module, identify its dependencies, and send out requests for its dependent modules. When these files are returned over the network, the browser will parse their contents, identify their dependencies, and send out more requests for those second-order dependencies if they are not already loaded. This recursive asynchronous process will continue until the entire application's dependency graph is resolved. Once the dependencies are resolved, the application can begin to formally load.

This process is very similar to the AMD style of module loading. Module files are loaded on demand, and successive rounds of module file requests are delayed by the network latency of each dependency module file. That is, if entry `moduleA` depends on `moduleB`, and `moduleB` depends on `moduleC`, the browser will not know to send a request for C until the request for B has first completed. This style of loading is efficient and requires no outside tooling, but loading a large application with a deep dependency graph may take too long.

Module Behavior

ECMAScript 6 modules borrow many of the best features from CommonJS and AMD predecessors. To name a few:

- Module code is only executed when it is loaded.
- A module will only ever be loaded a single time.

- Modules are singletons.
- Modules can define a public interface with which other modules can observe and interact.
- Modules can request that other modules be loaded.
- Circular dependencies are supported.

The ES6 module system also introduces new behavior:

- ES6 modules by default execute in strict mode.
- ES6 modules do not share a global namespace.
- The value of `this` at the top-level of a module is `undefined` (as opposed to `window` in the case of normal scripts).
- `var` declarations will not be added to the `window` object.
- ES6 modules are loaded and executed asynchronously.

The behavior described here characterizing an ECMAScript 6 module is conditionally enforced by the browser's runtime when it knows to consider a certain file to be a module. A JavaScript file is designated as a module either when it is associated with a `<script type="module">` or when it is loaded via an `import` statement.

Module Exports

The public exports system for ES6 modules is very similar to CommonJS. The `exports` keyword is used to control what parts of a module are visible to external modules. There are two types of exports in ES6 modules: named exports and default exports. Different types of exports means they are imported differently—this is covered in the following section.

The `export` keyword is used to declare a value as a named export. Exports must occur in the top-level of the module; they cannot be nested inside blocks:

```
// Allowed
export ...

// Disallowed
if (condition) {
  export ...
}
```

Exporting a value has no direct effect on JavaScript execution inside a module, so there is no restriction on the locality of the `export` statement relative to what is being exported, or what order the `export` keyword must appear in the module. An `export` may even precede the declaration of the value it is exporting:

```
// Allowed
const foo = 'foo';
export { foo };

// Allowed
export const foo = 'foo';
```

```
// Allowed, but avoid
export { foo };
const foo = 'foo';
```

A *named export* behaves as if the module is a container for exported values. Inline named exports, as the name suggests, can be performed in the same line as variable declaration. In the following example, a variable declaration is paired with an inline export. An external module could import this module, and the value `foo` would be available inside it as a property of that module:

```
export const foo = 'foo';
```

Declaration does not need to occur in the same line as the export; you can perform the declaration and export the identifier elsewhere in the module inside an *export clause*:

```
const foo = 'foo';
export { foo };
```

It is also possible to provide an alias when exporting. An alias must occur inside the export clause bracket syntax; therefore, declaring a value, exporting it, and providing an alias cannot all be done in the same line. In the following example, an external module would access this value by importing this module and using the `myFoo` export:

```
const foo = 'foo';
export { foo as myFoo };
```

Because ES6 named exports allow you to treat the module as a container, you can declare multiple named exports inside a single module. Values can be declared inside the export statement, or they can be declared prior to specifying it as an export:

```
export const foo = 'foo';
export const bar = 'bar';
export const baz = 'baz';
```

Because exporting multiple values is common behavior, grouping export declarations is supported, as is aliasing some or all of those exports:

```
const foo = 'foo';
const bar = 'bar';
const baz = 'baz';
export { foo, bar as myBar, baz };
```

A *default export* behaves as if the module is the same entity as the exported value. The `default` keyword modifier is used to declare a value as a default export, and there can only ever be a single default export. Attempting to specify duplicate default exports will result in a `SyntaxError`.

In the following example, an external module could import this module, and the module itself would be the value of `foo`:

```
const foo = 'foo';
export default foo;
```

Alternately, the ES6 module system will recognize the `default` keyword when provided as an alias, and will apply the default export to the value even though it uses the named export syntax:

```
const foo = 'foo';

// Behaves identically to "export default foo;"
export { foo as default };
```

Because there are no incompatibilities between named exports and default exports, ES6 allows you to use both in the same module:

```
const foo = 'foo';
const bar = 'bar';

export { bar };
export default foo;
```

The two export statements can be combined into the same line:

```
const foo = 'foo';
const bar = 'bar';

export { foo as default, bar };
```

The ES6 specification restricts what can and cannot be done inside various forms of an export statement. Some forms allow declaration and assignment, some forms allow only expressions, and some forms only allow simple identifiers. Note that some forms utilize semicolons, and some do not.

```
// Named inline exports
export const baz = 'baz';
export const foo = 'foo', bar = 'bar';
export function foo() {}
export function* foo() {}
export class Foo {}

// Named clause exports
export { foo };
export { foo, bar };
export { foo as myFoo, bar };

// Default exports
export default 'foo';
export default 123;
export default /[a-z]*/;
export default { foo: 'foo' };
export { foo, bar as default };
export default foo
export default function() {}
export default function foo() {}
export default function*() {}
export default class {}

// Various disallowed forms that will cause errors:

// Variable declarations cannot occur inside inline default exports
export default const foo = 'bar';

// Only identifiers can appear in export clauses
export { 123 as foo }

// Aliasing only can occur in export clauses
export const foo = 'foo' as myFoo;
```

NOTE *Rules for what can and cannot appear in the same line as the `export` keyword can be difficult to remember. Generally, it is a good practice to perform declarations and assignments separately, and later on export the identifier. This allows you to easily follow correct `export` syntax, as well as keep your `export` statements grouped together.*

Module Imports

Modules can use exports from other modules using the `import` keyword. Like `export`, `import` must appear in the top level of a module:

```
// Allowed
import ...

// Disallowed
if (condition) {
  import ...
}
```

`import` statements are hoisted to the top of the module. Therefore, like the `export` keyword, the order in which `import` statements appear relative to the use of the imported values is unimportant. It is recommended, however, that imports be kept at the top of the module.

```
// Allowed
import { foo } from './fooModule.js';
console.log(foo); // 'foo'

// Allowed, but avoid
console.log(foo); // 'foo'
import { foo } from './fooModule.js';
```

A module identifier can be either the relative path to that module file from the current module or the absolute path to that module file from the base path. It must be a plain string; the identifier cannot be dynamically computed, for example, concatenating strings.

If the modules are being natively loaded in the browser via the path in their module identifier, a `.js` extension is required for the correct file to be referenced. However, if the ES6 modules are being bundled or interpreted by a build tool or third-party module loader, you may not need to include the file extension of the module in its identifier.

```
// Resolves to /components/bar.js
import ... from './bar.js';

// Resolves to /bar.js
import ... from '../bar.js';

// Resolves to /bar.js
import ... from '/bar.js';
```

Modules do not need to be imported via their exported members. If you do not need specific exported bindings from a module, but you still need to load and execute the module for its side effects, you can load it with only its path:

```
import './foo.js';
```

Imports are treated as read-only views to the module, effectively the same as `const`-declared variables. When performing a bulk import using `*`, the aliased collection of named exports behaves as if it were treated with `Object.freeze()`. Direct manipulation of exported values is impossible, although modifying properties of an exported object is still possible. Adding or removing exported properties of the exported collection is also disallowed. Mutation of exported values must occur using exported methods that have access to internal variables and properties.

```
import foo, * as Foo './foo.js';

foo = 'foo'; // Error

Foo.foo = 'foo'; // Error

foo.bar = 'bar'; // Allowed
```

The distinction between named exports and default exports is mirrored in the way they are imported. Named exports can be retrieved in bulk without specifying their exact identifier using `*` and providing an identifier for the collection of exports:

```
const foo = 'foo', bar = 'bar', baz = 'baz';
export { foo, bar, baz }
import * as Foo from './foo.js';

console.log(Foo.foo); // foo
console.log(Foo.bar); // bar
console.log(Foo.baz); // baz
```

To perform explicit imports, the identifiers can be placed inside an *import clause*. Using an import clause also allows you to specify aliases for the imports:

```
import { foo, bar, baz as myBaz } from './foo.js';

console.log(foo); // foo
console.log(bar); // bar
console.log(myBaz); // baz
```

Default exports behave as if the module target is the exported value. They can be imported using the `default` keyword and providing an alias; alternately, they can be imported without the use of curly braces, and the identifier you specify is effectively the alias for the default export:

```
// Equivalent
import { default as foo } from './foo.js';
import foo from './foo.js';
```

If a module exports both named exports and default exports, it's possible to retrieve them in the same import statement. This retrieval can be performed by enumerating specific exports, or using `*`:

```
import foo, { bar, baz } from './foo.js';

import { default as foo, bar, baz } from './foo.js';

import foo, * as Foo from './foo.js';
```

NOTE *There is a proposal currently in stage 3 for dynamically importing modules:* <https://tc39.github.io/proposal-dynamic-import/>.

Module Passthrough Exports

Imported values can be piped directly through to an export. You are also able to convert default to named exports, and vice versa. If you wanted to incorporate all the named exports from one module into another, this can be accomplished with a `*` export:

```
export * from './foo.js';
```

All named exports in `foo.js` will be available when importing `bar.js`. This syntax will ignore the default value of `foo.js` if it has one. This syntax also requires care around export name collisions. If `foo.js` exports `baz`, and `bar.js` also exports `baz`, the ultimate export value will be the one specified in `bar.js`. This "overwrite" will occur silently:

foo.js

```
export const baz = 'origin:foo';
```

bar.js

```
export * from './foo.js';
export const baz = 'origin:bar';
import { baz } from './bar.js';
```

main.js

```
console.log(baz); // origin:bar
```

It's also possible to enumerate which values from the external module are being passed through to the local exports. This syntax supports aliasing:

```
export { foo, bar as myBar } from './foo.js';
```

Similarly, the default export of an imported module can be reused and exported as the default export of the current module:

```
export { default } from './foo.js';
```

This does not perform any copy of the export; it merely propagates the imported reference to the original module. The defined value of that import still lives in the original module, and the same restrictions involving mutation of imports apply to imports that are re-exported.

When performing a re-export, it is also possible to alter the named/default designation from the imported module. A named import can be specified as the default export as follows:

```
export { foo as default } from './foo.js';
```

Worker Modules

ECMAScript 6 modules are fully compatible with Worker instances. When instantiating, Workers can be passed a path to a module file in the same way you would pass a normal script file. The Worker constructor accepts a second argument allowing you to inform it that you are passing a module file.

Worker instantiation for both types of workers would behave as follows:

```
// Second argument defaults to { type: 'classic' }
const scriptWorker = new Worker('scriptWorker.js');

const moduleWorker = new Worker('moduleWorker.js', { type: 'module' });
```

Inside a module-based Worker, the `self.importScripts()` method is typically used to load external scripts inside a script-based Worker will throw an error. This is because a module's `import` behavior subsumes that of `importScripts()`.

Backwards Compatibility

Because adoption of ECMAScript module compatibility will be gradual, it is valuable for early module adopters to have the ability to develop for both browsers that support modules and browsers that do not. For users who want to natively use ECMAScript 6 modules in the browser when possible, solutions will involve serving two versions of your code—a module-based version and a script-based version. If this is undesirable to you, utilizing third-party module systems such as SystemJS or transpiling down ES6 modules at build time are better options.

The first strategy involves inspecting the browser's user-agent on the server, matching it against a known list of browsers that support modules, and using that to decide which JS files to serve. This method is brittle and complicated, and is not recommended. A better and more elegant solution to this is to make use of the `script type` attribute and the `script nomodule` attribute.

When a browser does not recognize the `type` attribute value of a `<script>` element, it will decline to execute its contents. For legacy browsers that do not support modules, this means that `<script type="module">` will never execute. Therefore, it is possible to place a fallback `<script>` tag right next to the `<script type="module">` tag:

```
// Legacy browser will not execute this
<script type="module" src="module.js"></script>

// Legacy browser will execute this
<script src="script.js"></script>
```

This, of course, leaves the problem of browsers that *do* support modules. In this case, the preceding code will execute twice—obviously an undesirable outcome. To prevent this, browsers that support ECMAScript 6 modules natively will also recognize the `nomodule` attribute. This attribute informs browsers that support ES6 modules to not execute the script. Legacy browsers will not recognize the attribute and ignore it.

Therefore, the following configuration will yield a setup in which both modern and legacy browsers will execute exactly one of these scripts:

```
// Modern browser will execute this
// Legacy browser will not execute this
<script type="module" src="module.js"></script>

// Modern browser will not execute this
// Legacy browser will execute this
<script nomodule src="script.js"></script>
```

SUMMARY

The module pattern remains a timeless tool for managing complexity. It allows developers to create segments of isolated logic, declare dependencies between these segments, and connect them together. What's more, the pattern is one that has proven to scale elegantly to arbitrary complexity and across platforms.

For years, the ecosystem grew around a contentious dichotomy between CommonJS, a module system targeted at server environments, and AMD, a module system targeted at latency-constrained client environments. Both systems enjoyed explosive growth, but the code written for each was in many ways at odds, and often incurred an unholy amount of boilerplate. What's more, neither system was natively implemented by browsers, and in the wake of this incompatibility rose a deluge of tooling that allowed for the module pattern to be used in browsers.

Included in the ECMAScript 6 specification is a wholly new concept for browser modules that takes the best of both worlds and combines them into a simpler declarative syntax. Browsers increasingly offer support for native module utilization, but also provide robust tooling to bridge the gap between marginal and full support for ES6 modules.

27

Workers

WHAT'S IN THIS CHAPTER?

- Introduction to workers
- Running background tasks with dedicated workers
- Using with shared workers
- Managing requests with service workers

The statement “JavaScript is single-threaded” is practically a mantra for the frontend development community. This assertion, although it makes some simplifying assumptions, effectively describes how the JavaScript environment generally behaves inside a browser. Therefore, it is useful as a pedagogical tool for helping web developers understand JavaScript.

This single-threaded paradigm is inherently restrictive as it prevents programming patterns that are otherwise feasible in languages capable of delegating work to separate threads or processes. JavaScript is bound to this single-threaded paradigm to preserve compatibility with the various browser APIs that it must interact with. Constructs such as the Document Object Model would encounter problems if subjected to concurrent mutations via multiple JavaScript threads. Therefore, traditional concurrency constructs such as POSIX threads or Java’s `Thread` class are non-starters for augmenting JavaScript.

Therein lies the core value proposition of workers: Allow the primary execution thread to delegate work to a separate entity without changing the existing single-threaded model. Although the various worker types covered in this chapter all have different forms and functions, they are unified in their separation from the primary JavaScript environment.

INTRODUCTION TO WORKERS

A single JavaScript environment is essentially a virtualized environment running inside the host operating system. Each open page in a browser is allocated its own environment. This provides each page its own memory, event loop, DOM, and so on. Each page is more or less sandboxed and cannot interfere with other pages. It is trivial for a browser to manage many environments at once—all of which are executing *in parallel*.

Using *workers*, browsers are able to allocate a second child environment that is totally separated from the original page environment. This child environment is prevented from interacting with single-thread-dependent constructs such as the DOM, but is otherwise free to execute code in parallel with the parent environment.

Comparing Workers and Threads

Introductory resources will commonly draw a comparison between workers and execution threads. In many ways, this is an apt comparison, as workers and threads do indeed share many characteristics:

- **Workers are implemented as actual threads.** For example, the Blink browser engine implements workers with a `WorkerThread` that corresponds to an underlying platform thread.
- **Workers execute in parallel.** Even though the page and the worker both implement the single-threaded JavaScript environment, instructions in each environment can be executed in parallel.
- **Workers can share *some* memory.** Workers are able to use a `SharedArrayBuffer` to share memory between multiple environments. Whereas threads will use locks to implement concurrency control, JavaScript uses the `Atomics` interface to implement concurrency control.

Workers and threads have a great deal of overlap, yet there are some important differences between them:

- **Workers do not share *all* memory.** In a traditional thread model, multiple threads have the capability to read and write to a shared memory space. With the exception of the `SharedArrayBuffer`, moving data in and out of workers requires it to be copied or transferred.
- **Worker threads are not necessarily part of the same process.** Typically, a single process is able to spawn multiple threads inside of it. Depending on the browser engine's implementation, a worker thread may or may not be part of the same process as the page. For example, Chrome's Blink engine uses a separate process for shared worker and service worker threads.
- **Worker threads are more expensive to create.** Worker threads include their own separate event loop, global objects, event handlers, and other features that are part and parcel of a JavaScript environment. The computational expense of creating these should not be overlooked.

In both form and function, workers are not a drop-in replacement for threads. The HTML Web Worker specification says the following:

Workers are relatively heavy-weight, and are not intended to be used in large numbers. For example, it would be inappropriate to launch one worker for each pixel of a four megapixel image. Generally, workers are expected to be long-lived, have a high start-up performance cost, and a high per-instance memory cost.

Types of Workers

There are three primary types of workers defined in the Web Worker specification: the *dedicated web worker*, the *shared web worker*, and the *service worker*. These are all widely available in modern web browsers.

NOTE *The Web Worker specification can be found at <https://html.spec.whatwg.org/multipage/workers.html>.*

Dedicated Web Worker

The dedicated web worker, usually just referred to as a dedicated worker, web worker, or just worker, is the bread-and-butter utility that allows scripts to spawn a separate JavaScript thread and delegate tasks to it. A dedicated worker, as the name suggests, can only be accessed by the page that spawned it.

Shared Web Worker

A shared web worker behaves much like a dedicated worker. The primary difference is that a shared worker can be accessed across multiple contexts, including different pages. Any scripts executing on the same origin as the script that originally spawned the shared worker can send and receive messages to a shared worker.

Service Worker

A service worker is wholly different from that of a dedicated or shared worker. Its primary purpose is to act as a network request arbiter capable of intercepting, redirecting, and modifying requests dispatched by the page.

NOTE *There is a handful of other worker specifications, such as the Chrome-Worker or Web Audio API. These are not widely supported, or they target niche applications and therefore are not included in the book.*

The WorkerGlobalScope

On a web page, the `window` object exposes a broad suite of global variables to scripts running inside it. Inside a worker, the concept of a "window" does not make sense, and therefore its global object

is an instance of `WorkerGlobalScope`. Instead of `window`, this global object is accessible via the `self` keyword.

WorkerGlobalScope Properties and Methods

The properties available on `self` are a strict subset of those available on `window`. Some properties return a worker-flavored version of the object:

- **navigator**—Returns the `WorkerNavigator` associated with this worker.
- **self**—Returns the `WorkerGlobalScope` object.
- **location**—Returns the `WorkerLocation` associated with this worker.
- **performance**—Returns a `Performance` object (with a reduced set of properties and methods).
- **console**—Returns the `Console` object associated with this worker. No restriction on API.
- **caches**—Returns the `CacheStorage` object associated with this worker. No restriction on API.
- **indexedDB**—Returns an `IDBFactory` object.
- **isSecureContext**—Returns a `Boolean` indicating if the context of the worker is secure.
- **origin**—Returns the origin of the `WorkerGlobalScope` object.

Similarly, some methods available on `self` are a subset of those available on `window`. The methods on `self` operate identically to their counterparts on `window`:

- `atob()`
- `btoa()`
- `clearInterval()`
- `clearTimeout()`
- `createImageBitmap()`
- `fetch()`
- `setInterval()`
- `setTimeout()`

The `WorkerGlobalScope` also introduces a new global method `importScripts()`, which is only available inside a worker. This method is described later in the chapter.

Subclasses of WorkerGlobalScope

The `WorkerGlobalScope` is not actually implemented anywhere. Each type of worker uses its own flavor of global object, which inherits from `WorkerGlobalScope`.

- A dedicated worker uses a `DedicatedWorkerGlobalScope`.

- A shared worker uses a `SharedWorkerGlobalScope`.
- A service worker uses a `ServiceWorkerGlobalScope`.

The differences between these global objects are discussed in their respective sections in this chapter.

DEDICATED WORKERS

A *dedicated worker* is the simplest type of web worker. Dedicated workers are created by a web page to execute scripts outside the page's thread of execution. These workers are capable of exchanging information with the parent page, sending network requests, performing file I/O, executing intense computation, processing data in bulk, or any other number of computational tasks that are unsuited for the page execution thread (where they would introduce latency issues).

NOTE *When dealing with workers, where a script is executing and where it was loaded from are important concepts. Unless otherwise specified, assume throughout this chapter that `main.js` is a top-level script loaded from and executing on the root path of the `https://example.com` domain.*

Dedicated Worker Basics

Dedicated workers can be aptly described as *background scripts*. The characteristics of a JavaScript worker—including lifecycle management, code path, and input/output—are governed by a singular script provided when the worker is initialized. This script may in turn request additional scripts, but a worker always begins with a single script source.

Creating a Dedicated Worker

The most common way to create a dedicated worker is through a loaded JavaScript file. The file path is provided to the `Worker` constructor, which in turn asynchronously loads the script in the background and instantiates the worker. The constructor requires a path to a file, although that path can take several different forms.

The following simple example creates an empty dedicated worker:

EMPTYWORKER.JS

```
// empty JS worker file
```

MAIN.JS

```
console.log(location.href); // "https://example.com/"
const worker = new Worker(location.href + 'emptyWorker.js');
console.log(worker); // Worker {}
```

This demonstration is trivial, but it involves several foundational concepts:

- The `emptyWorker.js` file is loaded from an absolute path. Depending on the structure of your application, using an absolute URL will often be redundant.
- This file is loaded in the background, and the worker initialization occurs on a thread totally separate from that of `main.js`.
- The worker itself exists in a separate JavaScript environment, so the `main.js` must use a `Worker` object as a proxy to communicate with that worker. In the above example, this object is assigned to the `worker` variable.
- Although the worker itself may not yet exist, this `Worker` object is available immediately inside the original environment.

The previous example could be altered to use a relative path; however, this requires that `main.js` is executing on the same path that `emptyWorker.js` can be loaded from:

```
const worker = new Worker('./emptyWorker.js');
console.log(worker); // Worker {}
```

Worker Security Restrictions

Worker script files can only be loaded from the same origin as the parent page. Attempts to load a worker script file from a remote origin will throw an error when attempting to construct the worker, as shown here:

```
// Attempt to build worker from script at https://example.com/worker.js
const sameOriginWorker = new Worker('./worker.js');

// Attempt to build worker from script at https://untrusted.com/worker.js
const remoteOriginWorker = new Worker('https://untrusted.com/worker.js');

// Error: Uncaught DOMException: Failed to construct 'Worker':
// Script at https://untrusted.com/main.js cannot be accessed
// from origin https://example.com
```

NOTE *The worker origin restriction does not prevent you from executing code from remote origins. This can be accomplished inside the worker via the use of `importScripts()`, which is covered later in the chapter.*

Workers created from a loaded script are not subject to the document's content security policy because workers execute in a separate context from the parent document. However, if the worker is loaded from a script with a globally unique identifier—as is the case when a worker is loaded from a blob—it *will* be subject to the content security policy of the parent document.

NOTE *Creating workers from blobs is covered in the “Creating a Worker from Inline JavaScript” section.*

Using the Worker Object

The `Worker` object returned from the `Worker()` constructor is used as the single point of communication with the newly created dedicated worker. It can be used to transmit information between the worker and the parent context, as well as catch events emitted from the dedicated worker.

NOTE *Carefully track references to the `Worker` objects associated with each worker you create. Until a worker is terminated, it cannot be garbage collected, and there is no programmatic tool that you can use to regain a reference to the worker object.*

The `Worker` object supports the following event handler properties:

- **`onerror`**—Can be assigned an event handler that will be called whenever an `ErrorEvent` of type `error` bubbles from the worker.
 - This event occurs when an error is thrown inside the worker.
 - This event can also be handled using `worker.addEventListener('error', handler)`.
- **`onmessage`**—Can be assigned an event handler that will be called whenever a `MessageEvent` of type `message` bubbles from the worker.
 - This event occurs when the worker script sends a message event back to the parent context.
 - This event can also be handled using `worker.addEventListener('message', handler)`.
- **`onmessageerror`**—Can be assigned an event handler that will be called whenever a `MessageEvent` of type `messageerror` event bubbles from the worker.
 - This event occurs when a message is received that cannot be deserialized.
 - This event can also be handled using `worker.addEventListener('messageerror', handler)`.

The `Worker` object also supports the following methods:

- **`postMessage()`**—Used to send information to the worker via asynchronous message events.
- **`terminate()`**—Used to immediately terminate the worker. No opportunity for cleanup is afforded to the worker, and the script is abruptly ended.

The DedicatedWorkerGlobalScope

Inside the dedicated worker, the global scope is an instance of `DedicatedWorkerGlobalScope`. This inherits from `WorkerGlobalScope` and therefore includes all its properties and methods. A worker is able to access this global scope via `self`:

GLOBALSCOPEWORKER.JS

```
console.log('inside worker:', self);
```

MAIN.JS

```
const worker = new Worker('./globalScopeWorker.js');

console.log('created worker:', worker);

// created worker: Worker {}
// inside worker: DedicatedWorkerGlobalScope {}
```

As shown here, the `console` object in both the top-level script and the worker will write to the browser console, which is useful for debugging. Because the web worker has a non-negligible startup latency, the worker's log message prints after the main thread's log message even though the `Worker` object exists.

NOTE *Note here that two separate JavaScript threads are sending messages to a singular `console` object, which subsequently serializes the messages and prints them in the browser console. The browser receives messages from two different JavaScript threads and is responsible for interleaving them as it sees fit. Because of this, using log messages from multiple threads to ascertain order of operation should be done with caution.*

`DedicatedWorkerGlobalScope` extends the `WorkerGlobalScope` with the following properties and methods:

- **name**—An optional string identifier that can be provided to the `Worker` constructor.
- **postMessage()**—The counterpart to `worker.postMessage()`. It is used to send messages back out of the worker to the parent context.
- **close()**—The counterpart to `worker.terminate()`. It is used to immediately terminate the worker. No opportunity for cleanup is afforded to the worker; the script is abruptly ended.
- **importScripts()**—Used to import an arbitrary number of scripts into the worker.

Dedicated Workers and Implicit MessagePorts

You will notice that the dedicated worker object and the `DedicatedWorkerGlobalScope` object share some pieces of interface handlers and methods with `MessagePort`: `onmessage`, `onmessageerror`, `close()`, and `postMessage()`. This is no accident: dedicated workers implicitly use a `MessagePort` to communicate between contexts.

The implementation is such that the object in the parent context and the `DedicatedWorkerGlobalScope` effectively absorb the `MessagePort` and expose its handlers and methods as part of their own interfaces. In other words, you are still sending messages via a `MessagePort`; you just aren't given access to the port itself.

There are some inconsistencies, such as the `start()` and `close()` conventions. Dedicated worker ports will automatically start the sending of queued messages so no `start()` is required. Furthermore, the `close()` method doesn't make sense in the context of a dedicated worker as closing the port would effectively orphan the worker. Therefore, a `close()` called from inside the worker (or `terminate()` from outside) will not just close the port but shut down the worker as well.

Understanding the Dedicated Worker Lifecycle

The `Worker()` constructor is the beginning of life for a dedicated worker. Once called, it initiates a request for the worker script and returns a `Worker` object to the parent context. Although the `Worker` object is immediately available for use in the parent context, the associated worker may not yet have been created due to the worker script's network latency or initialization latency.

Generally speaking, dedicated workers can be informally characterized as existing in one of three states: *initializing*, *active*, and *terminated*. The state of a dedicated worker is opaque to any other contexts. Although a `Worker` object may exist in the parent context, it cannot be ascertained if a dedicated worker is initializing, active, or terminated. In other words, a `Worker` object associated with an active dedicated worker is indistinguishable from a `Worker` object associated with a terminated dedicated worker.

While initializing, although the worker script has yet to begin execution, it is possible to enqueue messages for the worker. These messages will wait for the worker to become active and subsequently be added to its message queue. This behavior is demonstrated here:

INITIALIZINGWORKER.JS

```
self.addEventListener('message', ({data}) => console.log(data));
```

MAIN.JS

```
const worker = new Worker('./initializingWorker.js');

// Worker may still be initializing,
// yet postMessage data is handled correctly.
worker.postMessage('foo');
worker.postMessage('bar');
worker.postMessage('baz');

// foo
// bar
// baz
```

Once created, a dedicated worker will last the lifetime of the page unless explicitly terminated either via self-termination (`self.close()`) or external termination (`worker.terminate()`). Even when the worker script has run to completion, the worker environment will persist. As long as the worker is

still alive, the `Worker` object associated with it will not be garbage collected.

Self-termination and external termination ultimately perform the same worker termination routine. Consider the following example, where a worker self-terminates in between dispatching messages:

CLOSEWORKER.JS

```
self.postMessage('foo');
self.close();
self.postMessage('bar');
setTimeout(() => self.postMessage('baz'), 0);
```

MAIN.JS

```
const worker = new Worker('./worker.js');
worker.onmessage = ({data}) => console.log(data);

// foo
// bar
```

Although `close()` is invoked, clearly execution of the worker is not immediately terminated. `close()` only instructs the worker to discard all tasks in the event loop and prevent further tasks from being added. This is why "baz" never prints. It does *not* demand that synchronous execution halt, and therefore "bar" is still printed, as it is handled in the parent context's event loop.

Now, consider the following external termination example:

TERMINATEWORKER.JS

```
self.onmessage = ({data}) => console.log(data);
```

MAIN.JS

```
const worker = new Worker('./worker.js');

// Allow 1000ms for worker to initialize
setTimeout(() => {
  worker.postMessage('foo');
  worker.terminate();
  worker.postMessage('bar');
  setTimeout(() => worker.postMessage('baz'), 0);
}, 1000);

// foo
```

Here, the worker is first sent a `postMessage` with "foo," which it is able to handle prior to the external termination. Once `terminate()` is invoked, the worker's message queue is drained and locked—this is why only "foo" is printed.

NOTE Both `close()` and `terminate()` are idempotent operations; they may be called multiple times without harm. These methods merely serve to flag the worker for teardown, so invoking them multiple times will have no ill effects.

Over its lifecycle, a dedicated worker is associated with exactly one web page (referred to in the Web Worker specification as a *document*). Unless explicitly terminated, a dedicated worker will persist as long as the associated document exists. If the browser leaves the page (perhaps via navigation or closing a tab or window), the browser will flag workers associated with that document for termination, and their execution will immediately halt.

Configuring Worker Options

The `Worker()` constructor allows for an optional configuration object as the second argument. The configuration object supports the following properties:

- **name**—A string identifier that can be read from inside the worker via `self.name`.
- **type**—Specifies how the loaded script should be run, either `classic` or `module`. `classic` executes the script as a normal script; `module` executes the script as a module.
- **credentials**—When `type` is set to "module," specifies how worker module scripts should be retrieved with respect to transmitting credential data. Can be `omit`, `same-origin`, or `include`. These options operate identically to the `fetch()` `credentials` option. When `type` is set to `classic`, defaults to `omit`.

NOTE *Some modern browsers still do not fully support module workers or may require the use of a flag to enable their support.*

Creating a Worker from Inline JavaScript

Workers need to be created from a script file, but this does not mean that the script must be loaded from a remote resource. A dedicated worker can also be created from an inline script via a blob object URL. This allows for faster worker initialization due to the elimination of roundtrip network latency.

The following example creates a worker from an inline script:

```
// Create string of JavaScript code to execute
const workerScript = `
  self.onmessage = ({data}) => console.log(data);
`;

// Generate a blob instance from the script string
const workerScriptBlob = new Blob([workerScript]);

// Create an object URL for the blob instance
const workerScriptBlobUrl = URL.createObjectURL(workerScriptBlob);

// Create a dedicated worker from the blob
const worker = new Worker(workerScriptBlobUrl);

worker.postMessage('blob worker script');
// blob worker script
```

In this example, the script string is passed into a blob instance, which is then assigned an object URL, which in turn is passed to the `Worker()` constructor. The constructor happily creates the dedicated worker as normal.

Condensed, this same example could appear as follows:

```
const worker = new Worker(URL.createObjectURL(new Blob(['self.onmessage =
({data}) => console.log(data);`])));

worker.postMessage('blob worker script');
// blob worker script
```

Workers can also take advantage of function serialization with inline script initialization. Because a function's `toString()` method returns the actual function code, a function can be defined in a parent context but executed in a child context. Consider the following simple example of this:

```
function fibonacci(n) {
  return n < 1 ? 0
    : n <= 2 ? 1
    : fibonacci(n - 1) + fibonacci(n - 2);
}

const workerScript = `
  self.postMessage(
    (${fibonacci.toString()}) (9)
  );
`;

const worker = new Worker(URL.createObjectURL(new Blob([workerScript])));

worker.onmessage = ({data}) => console.log(data);

// 34
```

Here, this intentionally expensive implementation of a Fibonacci sequence is serialized and passed into a worker. It's invoked as an immediately invoked function expression (IIFE) and passed a parameter, and the result is messaged back up to the main thread. Even though the Fibonacci computation here is quite expensive, all the computation is delegated to the worker and therefore does not harm the performance of the parent context.

NOTE *Importantly, this function serialization method requires that the function passed in does not use any references obtained through a closure, including global variables like `window`, as these will break when executed inside the worker.*

Dynamic Script Execution Inside a Worker

Worker scripts do not need to be monolithic entities. You are able to programmatically load and execute an arbitrary number of scripts with the `importScripts()` method, which is available on the global worker object. This method will load scripts and *synchronously* execute them in order. Consider the following example, which loads and executes two scripts:

MAIN.JS

```
const worker = new Worker('./worker.js');

// importing scripts
// scriptA executes
// scriptB executes
// scripts imported
```

SCRIPTA.JS

```
console.log('scriptA executes');
```

SCRIPTB.JS

```
console.log('scriptB executes');
```

WORKER.JS

```
console.log('importing scripts');

importScripts('./scriptA.js');
importScripts('./scriptB.js');

console.log('scripts imported');
```

`importScripts()` accepts an arbitrary number of script arguments. The browser may download them in any order, but the scripts will be strictly executed in parameter order. Therefore, the following worker script would be equivalent:

```
console.log('importing scripts');

importScripts('./scriptA.js', './scriptB.js');

console.log('scripts imported');
```

Script loading is subject to normal CORS restrictions, but otherwise workers are free to request scripts from other origins. This import strategy is analogous to dynamic script loading via `<script>` tag generation. In that spirit, scope is shared with imported scripts. This behavior is demonstrated here:

MAIN.JS

```
const worker = new Worker('./worker.js', {name: 'foo'});

// importing scripts in foo with bar
// scriptA executes in foo with bar
// scriptB executes in foo with bar
// scripts imported
```

SCRIPTA.JS

```
console.log(`scriptA executes in ${self.name} with ${globalToken}`);
```

SCRIPTB.JS

```
console.log(`scriptB executes in ${self.name} with ${globalToken}`);
```

WORKER.JS

```
const globalToken = 'bar';

console.log(`importing scripts in ${self.name} with ${globalToken}`);

importScripts('./scriptA.js', './scriptB.js');

console.log('scripts imported');
```

Delegating Tasks to Subworkers

You may find the need for workers to spawn their own "subworkers." This can be useful in cases where you have multiple CPU cores at your disposal for parallelization of computation. Electing to use a subworker model should be done only after a careful design consideration: running multiple web workers may incur a considerable computational overhead and should only be done if the gains from parallelization outweigh the costs.

Subworker creation works nearly identically to normal worker creation with the exception of path resolution: a subworker script path will be resolved with respect to its parent worker rather than the main page. This is demonstrated as follows (note the addition of the script directory):

MAIN.JS

```
const worker = new Worker('./js/worker.js');

// worker
// subworker
```

JS/WORKER.JS

```
console.log('worker');

const worker = new Worker('./subworker.js');
```

JS/SUBWORKER.JS

```
console.log('subworker');
```

NOTE *Both top-level worker scripts and subworker scripts must be loaded from the same origin as the main page.*

Handling Worker Errors

If an error is thrown inside a worker script, the worker's sandboxing will serve to prevent it from interrupting the parent thread of execution. This is demonstrated here, where an enclosing `try/catch` block does not catch the thrown error:

MAIN.JS

```
try {
  const worker = new Worker('./worker.js');
  console.log('no error');
} catch(e) {
  console.log('caught error!');
}

// no error
```

WORKER.JS

```
throw Error('foo');
```

However, this event will still bubble up to the global worker context and can be accessed by setting an error event listener on the `Worker` object. This is demonstrated here:

MAIN.JS

```
const worker = new Worker('./worker.js');
worker.onerror = console.log;

// ErrorEvent {message: "Uncaught Error: foo"}
```

WORKER.JS

```
throw Error('foo');
```

Communicating with a Dedicated Worker

All communication to and from a worker occurs via asynchronous messages, but these messages can take on a handful of different forms.

Communicating with `postMessage()`

The easiest and most common form is using `postMessage()` to pass serialized messages back and forth. A simple factorial example of this is shown here:

FACTORIALWORKER.JS

```
function factorial(n) {
  let result = 1;
  while(n) { result *= n--; }
  return result;
}
```

```
self.onmessage = ({data}) => {
  self.postMessage(`${data}! = ${factorial(data)}`);
};
```

MAIN.JS

```
const factorialWorker = new Worker('./factorialWorker.js');

factorialWorker.onmessage = ({data}) => console.log(data);

factorialWorker.postMessage(5);
factorialWorker.postMessage(7);
factorialWorker.postMessage(10);

// 5! = 120
// 7! = 5040
// 10! = 3628800
```

For simple message passing, using `postMessage()` to communicate between window and worker is extremely similar to message passing between two windows. The primary difference is that there is no concept of a `targetOrigin` restriction, which is present for `Window.prototype.postMessage` but not `WorkerGlobalScope.prototype.postMessage` or `Worker.prototype.postMessage`. The reason for this convention is simple: the worker script origin is restricted to the main page origin so there is no use for a filtering mechanism.

Communicating with MessageChannel

For both the main thread and the worker thread, communication via `postMessage()` involves invoking a method on the global object and defining an ad-hoc transmission protocol therein. This can be replaced by the Channel Messaging API, which allows you to create an explicit communication channel between the two contexts.

A `MessageChannel` instance has two ports representing the two communication endpoints. To enable a parent page and a worker to communicate over a channel, one port can be passed into the worker, as shown here:

WORKER.JS

```
// Store messagePort globally inside listener
let messagePort = null;

function factorial(n) {
  let result = 1;
  while(n) { result *= n--; }
  return result;
}

// Set message handler on global object
self.onmessage = ({ports}) => {
  // Only set the port a single time
  if (!messagePort) {
    // Initial message sends the port,
    // assign to variable and unset listener

```

```

    messagePort = ports[0];
    self.onmessage = null;

    // Set message handler on global object
    messagePort.onmessage = ({data}) => {
      // Subsequent messages send data
      messagePort.postMessage(`${data}! = ${factorial(data)}`);
    };
  }
};

```

MAIN.JS

```

const channel = new MessageChannel();
const factorialWorker = new Worker('./worker.js');

// Send the MessagePort object to the worker.
// Worker is responsible for handling this correctly
factorialWorker.postMessage(null, [channel.port1]);

// Send the actual message on the channel
channel.port2.onmessage = ({data}) => console.log(data);

// Worker will respond on the channel
channel.port2.postMessage(5);

// // 5! = 120

```

In this example, the parent page shares a `MessagePort` with a worker via `postMessage`. The array notation is to pass a transferable object between contexts. This concept is covered later in the chapter. The worker maintains a reference to this port and uses it to transmit messages in lieu of transmitting them via the global object. Of course, this format still utilizes a kind of ad-hoc protocol: the worker is written to expect the first message to send the port and subsequent messages to send data.

Using a `MessageChannel` instance to communicate with the parent page is largely redundant, as the global `postMessage` affordance is essentially performing the same task as `channel.postMessage` (not including the additional features of the `MessageChannel` interface). A `MessageChannel` truly becomes useful in a situation in which two workers would like to directly communicate with one another. This can be accomplished by passing one port into each worker. Consider the following example where an array is passed into a worker, passed to another worker, and passed back up to the main page:

MAIN.JS

```

const channel = new MessageChannel();
const workerA = new Worker('./worker.js');
const workerB = new Worker('./worker.js');

workerA.postMessage('workerA', [channel.port1]);
workerB.postMessage('workerB', [channel.port2]);

workerA.onmessage = ({data}) => console.log(data);
workerB.onmessage = ({data}) => console.log(data);

```

```
workerA.postMessage(['page']);

// ['page', 'workerA', 'workerB']

workerB.postMessage(['page'])

// ['page', 'workerB', 'workerA']
```

WORKER.JS

```
let messagePort = null;
let contextIdentifier = null;

function addContextAndSend(data, destination) {
  // Add identifier to show when it reached this worker
  data.push(contextIdentifier);

  // Send data to next destination
  destination.postMessage(data);
}

self.onmessage = ({data, ports}) => {
  // If ports exist in the message,
  // set up the worker
  if (ports.length) {
    // Record the identifier
    contextIdentifier = data;

    // Capture the MessagePort
    messagePort = ports[0];

    // Add a handler to send the received data
    // back up to the parent
    messagePort.onmessage = ({data}) => {
      addContextAndSend(data, self);
    }
  } else {
    addContextAndSend(data, messagePort);
  }
};
```

In this example, each part of the array's journey will add a string to the array to mark when it arrived. The array is passed from the parent page into a worker, which adds its context identifier. It is then passed from one worker to the other, which adds a second context identifier. It is then passed back up to the main page, where the array is logged. Note in this example how, because the two workers share a common script, this array passing scheme works bidirectionally.

Communicating with BroadcastChannel

Scripts that run on the same origin are capable of sending and receiving conmessages on a shared `BroadcastChannel`. This channel type is simpler to set up and doesn't require the messiness of port passing required with `MessageChannel`. This can be accomplished as follows:

MAIN.JS

```
const channel = new BroadcastChannel('worker_channel');
```

```

const worker = new Worker('./worker.js');

channel.onmessage = ({data}) => {
  console.log(`heard ${data} on page`);
}

setTimeout(() => channel.postMessage('foo'), 1000);

// heard foo in worker
// heard bar on page

```

WORKER.JS

```

const channel = new BroadcastChannel('worker_channel');

channel.onmessage = ({data}) => {
  console.log(`heard ${data} in worker`);
  channel.postMessage('bar');
}

```

Note here that the page waits 1,000 milliseconds before sending the initial message on the `BroadcastChannel`. Because there is no concept of port ownership with this type of channel, messages broadcasted will not be handled if there is no other entity listening on the channel. In this case, without the `setTimeout`, the latency of the worker initialization is sufficiently long to prevent the worker's message handler from being set before the message is actually sent.

Worker Data Transfer

Workers will often need to be provided with a data payload in some form. Because workers operate in a separate context, there is overhead involved in getting a piece of data from one context to another. In languages that support traditional models of multithreading, you have concepts such as locks, mutexes, and volatile variables at your disposal. In JavaScript, there are three ways of moving information between contexts: the *structured clone algorithm*, *transferable objects*, and *shared array buffers*.

Structured Clone Algorithm

The *structured clone algorithm* can be used to share a piece of data between two separate execution contexts. This algorithm is implemented by the browser behind the scenes, but it cannot be invoked explicitly.

When an object is passed to `postMessage()`, the browser traverses the object and makes a copy in the destination context. The following types are fully supported by the structured clone algorithm:

- All primitive types except `Symbol`
- `Boolean` object
- `String` object
- `BDate`
- `RegExp`

- Blob
- File
- FileList
- ArrayBuffer
- ArrayBufferView
- ImageData
- Array
- Object
- Map
- Set

Some things to note about the behavior of the structured clone algorithm:

- Once copied, mutations to the object in the source context will not be propagated to the destination context object.
- The structured clone algorithm recognizes when an object contains a cycle and will not infinitely traverse the object.
- Attempting to clone an `Error` object, a `Function` object, or a DOM node will throw an error.
- The structured clone algorithm will not always create an exact copy.
- Object property descriptors, getters, and setters are not cloned and will revert to defaults where applicable.
- Prototype chains are not cloned.
- The `RegExp.prototype.lastIndex` property is not cloned.

NOTE *The structured clone algorithm can be computationally expensive when the object being copied is large. Avoid large or excessive copying when possible.*

Transferable Objects

It is possible to transfer ownership from one context to another using *transferable objects*. This is especially useful in cases where it is impractical to copy large amounts of data between contexts. Only a handful of types are transferable:

- ArrayBuffer
- MessagePort

- ImageBitmap
- OffscreenCanvas

The second optional argument to `postMessage()` is an array specifying which objects should be transferred to the destination context. When traversing the message payload object, the browser will check object references against the transfer object array and perform a transfer upon those objects instead of copying them. This means that transferred objects can be sent in a message payload, which itself is copied, such as an object or array.

The following example demonstrates a normal structured clone of an `ArrayBuffer` into a worker. No object transfer occurs in this example:

MAIN.JS

```
const worker = new Worker('./worker.js');

// Create 32 byte buffer
const arrayBuffer = new ArrayBuffer(32);

console.log(`page's buffer size: ${arrayBuffer.byteLength}`); // 32

worker.postMessage(arrayBuffer);

console.log(`page's buffer size: ${arrayBuffer.byteLength}`); // 32
```

WORKER.JS

```
self.onmessage = ({data}) => {
  console.log(`worker's buffer size: ${data.byteLength}`); // 32
};
```

When the `ArrayBuffer` is specified as a transferable object, the reference to the buffer memory is wiped out in the parent context and allocated to the worker context. This is demonstrated here, where the memory allocated inside the `ArrayBuffer` is removed from the parent context:

MAIN.JS

```
const worker = new Worker('./worker.js');

// Create 32 byte buffer
const arrayBuffer = new ArrayBuffer(32);

console.log(`page's buffer size: ${arrayBuffer.byteLength}`); // 32

worker.postMessage(arrayBuffer, [arrayBuffer]);

console.log(`page's buffer size: ${arrayBuffer.byteLength}`); // 0
```

WORKER.JS

```
self.onmessage = ({data}) => {
  console.log(`worker's buffer size: ${data.byteLength}`); // 32
};
```

It is perfectly fine to nest transferable objects inside other object types. The encompassing object will be copied and the nested object will be transferred:

MAIN.JS

```
const worker = new Worker('./worker.js');

// Create 32 byte buffer
const arrayBuffer = new ArrayBuffer(32);

console.log(`page's buffer size: ${arrayBuffer.byteLength}`); // 32

worker.postMessage({foo: {bar: arrayBuffer}}, [arrayBuffer]);

console.log(`page's buffer size: ${arrayBuffer.byteLength}`); // 0
```

WORKER.JS

```
self.onmessage = ({data}) => {
  console.log(`worker's buffer size: ${data.foo.bar.byteLength}`); // 32
};
```

SharedArrayBuffer

NOTE *The SharedArrayBuffer was disabled across all major browsers in January 2018 due to Spectre (<https://cve.mitre.org/cgi-bin/cvename.cgi?name=CVE-2017-5753>) and Meltdown (<https://cve.mitre.org/cgi-bin/cvename.cgi?name=CVE-2017-5754>) vulnerabilities. As of 2019, some browsers have begun to gradually re-enable the feature.*

Rather than being cloned or transferred, a SharedArrayBuffer is an ArrayBuffer that is shared between browser contexts. When passing a SharedArrayBuffer inside `postMessage()`, the browser will pass only a reference to the original buffer. As a result, two different JavaScript contexts will each maintain their own reference to the same block of memory. Each context is free to modify the buffer as it would with a normal ArrayBuffer. This behavior is demonstrated here:

MAIN.JS

```
const worker = new Worker('./worker.js');

// Create 1 byte buffer
const sharedArrayBuffer = new SharedArrayBuffer(1);

// Create view onto 1 byte buffer
const view = new Uint8Array(sharedArrayBuffer);

// Parent context assigns value of 1
view[0] = 1;
```

```

worker.onmessage = () => {
  console.log(`buffer value after worker modification: ${view[0]}`);
};

// Send reference to sharedArrayBuffer
worker.postMessage(sharedArrayBuffer);

// buffer value before worker modification: 1
// buffer value after worker modification: 2

```

WORKER.JS

```

self.onmessage = ({data}) => {
  const view = new Uint8Array(data);

  console.log(`buffer value before worker modification: ${view[0]}`);

  // Worker assigns new value to shared buffer
  view[0] += 1;

  // Send back empty postMessage to signal assignment is complete
  self.postMessage(null);
};

```

Of course, sharing the block of memory between two parallel threads introduces a risk of race conditions. In other words, the `SharedArrayBuffer` instance is effectively being treated as volatile memory. This problem is demonstrated in the following example:

MAIN.JS

```

// Create worker pool of size 4
const workers = [];
for (let i = 0; i < 4; ++i) {
  workers.push(new Worker('./worker.js'));
}

// Log the final value after the last worker completes
let responseCount = 0;
for (const worker of workers) {
  worker.onmessage = () => {
    if (++responseCount == workers.length) {
      console.log(`Final buffer value: ${view[0]}`);
    }
  };
}

// Initialize the SharedArrayBuffer
const sharedArrayBuffer = new SharedArrayBuffer(4);
const view = new Uint32Array(sharedArrayBuffer);
view[0] = 1;

```

```

// Send the SharedArrayBuffer to each worker
for (const worker of workers) {
  worker.postMessage(sharedArrayBuffer);
}

// (Expected result is 4000001. Actual output will be something like:)
// Final buffer value: 2145106

```

WORKER.JS

```

self.onmessage = ({data}) => {
  const view = new Uint32Array(data);

  // Perform 1000000 add operations
  for (let i = 0; i < 1E6; ++i) {
    view[0] += 1;
  }

  self.postMessage(null);
};

```

Here, each worker is executing 1,000,000 sequential operations, which read from the shared array index, perform an add, and write that value back into the array index. A race condition occurs when worker read/write operations are interleaved. For example:

1. Worker A reads a value of 1.
2. Worker B reads a value of 1.
3. Worker A adds 1 and writes 2 back into the array.
4. Worker B, still using the stale array value of 1, writes 2 back into the array.

To address this, the `Atomics` global object allows for a worker to effectively obtain a lock on the `SharedArrayBuffer` instance and perform the entire read/add/write sequence before allowing another worker to perform any operations. Incorporating `Atomics.add()` into this example yields a correct final value:

MAIN.JS

```

// Create worker pool of size 4
const workers = [];
for (let i = 0; i < 4; ++i) {
  workers.push(new Worker('./worker.js'));
}

// Log the final value after the last worker completes
let responseCount = 0;
for (const worker of workers) {
  worker.onmessage = () => {
    if (++responseCount == workers.length) {
      console.log(`Final buffer value: ${view[0]}`);
    }
  };
}

```

```
// Initialize the SharedArrayBuffer
const sharedArrayBuffer = new SharedArrayBuffer(4);
const view = new Uint32Array(sharedArrayBuffer);
view[0] = 1;

// Send the SharedArrayBuffer to each worker
for (const worker of workers) {
  worker.postMessage(sharedArrayBuffer);
}

// (Expected result is 4000001)
// Final buffer value: 4000001
```

WORKER.JS

```
self.onmessage = ({data}) => {
  const view = new Uint32Array(data);

  // Perform 1000000 add operations
  for (let i = 0; i < 1E6; ++i) {
    Atomics.add(view, 0, 1);
  }

  self.postMessage(null);
};
```

NOTE *The SharedArrayBuffer and Atomics API are fully covered in the chapter “JavaScript APIs.”*

Worker Pools

Because starting a worker is quite expensive, there may be situations where it is more efficient to keep a fixed number of workers alive and dispatch work to them as necessary. When a worker is performing computation, it is marked as busy and will only be ready to take on another task once it notifies the pool that it is available again. This is commonly referred to as a “thread pool” or “worker pool.”

Determining the ideal number of workers in a pool is not an exact science, but the `navigator.hardwareConcurrency` property will return the number of cores available on the system. Because you will likely not be able to ascertain the multithreading ability of each core, it may be best to treat this number as the upper bound for pool size.

One scenario you may encounter involves a fixed set of workers in a pool all performing the same task that is controlled by a small set of input parameters. By using a task-specific worker pool, you can allocate a fixed number of workers and feed them parameters on demand. The worker will take in these parameters, perform the long-running computation, and return the value to the pool. In turn, the pool will then send the worker additional work to perform. This example will build a relatively simplistic worker pool, but it will cover all the foundational requirements for this concept.

Begin by defining a `TaskWorker`, which extends the `Worker` class. This class has two jobs: keep track of whether or not it is busy performing work, and manage the information and events going in and out of the worker. Furthermore, tasks passed to this worker will be wrapped in a promise and will resolve/reject appropriately. The class can be defined as follows:

```
class TaskWorker extends Worker {
  constructor(notifyAvailable, ...workerArgs) {
    super(...workerArgs);

    // Initialize as unavailable
    this.available = false;
    this.resolve = null;
    this.reject = null;

    // Worker pool will pass a callback so that the
    // worker can signal it needs another task
    this.notifyAvailable = notifyAvailable;

    // Worker script will send a 'ready' postmessage
    // once fully initialized
    this.onmessage = () => this.setAvailable();
  }

  // Called by the worker pool to begin a new task
  dispatch({ resolve, reject, postMessageArgs }) {
    this.available = false;

    this.onmessage = ({ data }) => {
      resolve(data);
      this.setAvailable();
    };

    this.onerror = (e) => {
      reject(e);
      this.setAvailable();
    };

    this.postMessage(...postMessageArgs);
  }

  setAvailable() {
    this.available = true;
    this.resolve = null;
    this.reject = null;
    this.notifyAvailable();
  }
}
```

Next, the `WorkerPool` class definition must make use of this `TaskWorker` class. It must also maintain a queue of tasks that have yet to be assigned to a worker. Two events can signal that a new task should be dispatched: a new task is added to the queue, or a worker finishes a task and should be sent another. The class can be defined as follows:

```
class WorkerPool {
  constructor(poolSize, ...workerArgs) {
```

```

    this.taskQueue = [];
    this.workers = [];

    // Initialize the worker pool
    for (let i = 0; i < poolSize; ++i) {
        this.workers.push(
            new TaskWorker(() => this.dispatchIfAvailable(), ...workerArgs));
    }

    // Pushes a task onto the queue
    enqueue(...postMessageArgs) {
        return new Promise((resolve, reject) => {
            this.taskQueue.push({ resolve, reject, postMessageArgs });

            this.dispatchIfAvailable();
        });
    }

    // Sends a task to the next available worker if there is one
    dispatchIfAvailable() {
        if (!this.taskQueue.length) {
            return;
        }
        for (const worker of this.workers) {
            if (worker.available) {
                let a = this.taskQueue.shift();
                worker.dispatch(a);
                break;
            }
        }
    }

    // Kills all the workers
    close() {
        for (const worker of this.workers) {
            worker.terminate();
        }
    }
}

```

With these two classes defined, it is now trivial to dispatch tasks to the worker pool and have them be executed as workers become available. In this example, suppose you wanted to sum 10 million floating point numbers. To save on transfer costs, this will utilize a `SharedArrayBuffer`. The worker definition might appear as follows:

```

self.onmessage = ({data}) => {
    let sum = 0;
    let view = new Float32Array(data.arrayBuffer)

    // Perform sum
    for (let i = data.startIdx; i < data.endIdx; ++i) {
        // No need for Atomics since only performing reads
        sum += view[i];
    }
}

```

```

    // Send the result to the worker
    self.postMessage(sum);
  };

  // Send messagemessate to TaskWorker to signal worker is
  // ready to receive tasks.
  self.postMessage('ready');

```

With all this in place, the code that utilizes the worker pools might appear as follows:

```

Class TaskWorker {
  ...
}

Class WorkerPool {
  ...
}

const totalFloats = 1E8;
const numTasks = 20;
const floatsPerTask = totalFloats / numTasks;
const numWorkers = 4;

// Create pool
const pool = new WorkerPool(numWorkers, './worker.js');

// Fill array of floats
let arrayBuffer = new SharedArrayBuffer(4 * totalFloats);
let view = new Float32Array(arrayBuffer);
for (let i = 0; i < totalFloats; ++i) {
  view[i] = Math.random();
}

let partialSumPromises = [];
for (let i = 0; i < totalFloats; i += floatsPerTask) {
  partialSumPromises.push(
    pool.enqueue({
      startIdx: i,
      endIdx: i + floatsPerTask,
      arrayBuffer: arrayBuffer
    })
  );
}

// Wait for all promises to complete, then sum
Promise.all(partialSumPromises)
  .then((partialSums) => partialSums.reduce((x, y) => x + y))
  .then(console.log);

// (In this example, sum should be roughly 1E8/2)
// 49997075.47203197

```

NOTE *Blindly introducing parallelization is not a one-size-fits-all upgrade. Performance tuning for worker pools will vary by what the task computation involves and what the system hardware is.*

SHARED WORKERS

A *shared web worker* or *shared worker* behaves like a dedicated worker but is accessible across multiple trusted execution contexts. For example, two different tabs on the same origin will be able to access a single web worker. `SharedWorker` and `Worker` feature slightly different messaging interfaces, both externally and internally.

A shared worker is valuable in situations where the developer wishes to reduce computational overhead by allowing multiple execution contexts to share a worker. An example of this could be a single shared worker managing a websocket to send and receive messages for multiple same-origin pages. Shared workers are also useful when same-origin contexts wish to communicate via the shared worker.

Shared Worker Basics

Behaviorally speaking, shared workers can be considered an extension of dedicated workers. Worker creation, worker options, security restrictions, and `importScripts()` all behave in the same way. As is the case with a dedicated worker, the shared worker also runs inside a separate execution context and can only communicate asynchronously with other contexts.

Creating a Shared Worker

As with dedicated workers, the most common way of creating a shared worker is through a loaded JavaScript file. The file path is provided to the `SharedWorker` constructor, which in turn asynchronously loads the script in the background and instantiates the worker.

The following simple example creates an empty shared worker from an absolute path:

```
EMPTYSHAREDWORKER.JS
```

```
// empty JS worker file
```

```
MAIN.JS
```

```
console.log(location.href); // "https://example.com/"
const sharedWorker = new SharedWorker(
  location.href + 'emptySharedWorker.js');
console.log(sharedWorker); // SharedWorker {}
```

The previous example could be altered to use a relative path; however, this requires that `main.js` is executing on the same path that `emptySharedWorker.js` can be loaded from:

```
const worker = new Worker('./emptyWorker.js');
console.log(worker); // Worker {}
```

Shared workers can also be created from an inline script, but there is little point in doing so: each blob created from an inline script string is assigned its own unique in-browser URL, and therefore shared workers created from inline scripts will always be unique. The reasons for this are covered in the next section.

SharedWorker Identity and Single Occupancy

An important difference between a shared worker and a dedicated worker is that, whereas the `Worker()` constructor always creates a new worker instance, the `SharedWorker()` constructor will only create a new worker instance if one with the same identity does not yet exist. If a shared worker matching the identity *does* exist, a new connection will be formed with the existing shared worker.

Shared worker identity is derived from the resolved script URL, the worker name, and the document origin. For example, the following script would instantiate a single shared worker and add two subsequent connections:

```
// Instantiates single shared worker
// - Constructors called all on same origin
// - All scripts resolve to same URL
// - All workers have same name
new SharedWorker('./sharedWorker.js');
new SharedWorker('./sharedWorker.js');
new SharedWorker('./sharedWorker.js');
```

Similarly, because all three of the following script strings resolve to the same URL, only a single shared worker is created:

```
// Instantiates single shared worker
// - Constructors called all on same origin
// - All scripts resolve to same URL
// - All workers have same name
new SharedWorker('./sharedWorker.js');
new SharedWorker('sharedWorker.js');
new SharedWorker('https://www.example.com/sharedWorker.js');
```

Because the optional worker name is part of the shared worker identity, using different worker names will coerce the browser to create multiple shared workers—one with name `'foo'` and one with name `'bar'`—even though they have the same origin and script URL:

```
// Instantiates two shared workers
// - Constructors called all on same origin
// - All scripts resolve to same URL
// - One shared worker has name 'foo', one has name 'bar'
new SharedWorker('./sharedWorker.js', {name: 'foo'});
new SharedWorker('./sharedWorker.js', {name: 'foo'});
new SharedWorker('./sharedWorker.js', {name: 'bar'});
```

As the name implies, shared workers are shared across tabs, windows, iframes, or other workers running on the same origin. Therefore, the following script run on multiple tabs will only create a worker the first time it is executed, and each successive run will connect to that same worker:

```
// Instantiates single shared worker
// - Constructors called all on same origin
// - All scripts resolve to same URL
// - All workers have same name
new SharedWorker('./sharedWorker.js');
```

The script aspect of the shared worker identity is restricted to the URL only, so the following will create two shared workers even though the same script is loaded:

```
// Instantiates two shared workers
// - Constructors called all on same origin
// - '?' token differentiates URLs
// - All workers have same name
new SharedWorker('./sharedWorker.js');
new SharedWorker('./sharedWorker.js?');
```

If this script was run in two different tabs, there would still only be two shared workers created in total. Each constructor would check for a matching shared worker and merely connect to it if it exists.

Using the SharedWorker Object

The `SharedWorker` object returned from the `SharedWorker()` constructor is used as the single point of communication with the newly created dedicated worker. It can be used to transmit information between the worker and the parent context via a `MessagePort`, as well as catch `error` events emitted from the dedicated worker.

The `SharedWorker` object supports the following properties:

- **onerror**—Can be assigned an event handler that will be called whenever an `ErrorEvent` of type `error` bubbles from the worker.
 - This event occurs when an error is thrown inside the worker.
 - This event can also be handled using `sharedWorker.addEventListener('error', handler)`.
- **port**—The dedicated `MessagePort` for communication with the shared worker.

The SharedWorkerGlobalScope

Inside the shared worker, the global scope is an instance of `SharedWorkerGlobalScope`. This inherits from `WorkerGlobalScope` and therefore includes all its properties and methods. As with dedicated workers, a shared worker is able to access this global scope via `self`.

`SharedWorkerGlobalScope` extends the `WorkerGlobalScope` with the following properties and methods:

- **name**—An optional string identifier, which can be provided to the `SharedWorker` constructor.
- **importScripts()**—Used to import an arbitrary number of scripts into the worker.

- **close()**—The counterpart to `worker.terminate()`. It is used to immediately terminate the worker. No opportunity for cleanup is afforded to the worker; the script is abruptly ended.
- **onconnect**—Should be set as the handler for when a new connection is made to the shared worker. `connect` events include a `ports` array of `MessagePort` instances, which can be used to send messages back up to the parent context.
 - The `connect` event occurs when a connection is made to the shared worker either via `worker.port.onmessage` or `worker.port.start()`.
 - This event can also be handled using `sharedWorker.addEventListener('connect', handler)`.

NOTE *Depending on the browser implementation, logging to console inside the `SharedWorker` may not print in the default browser console view.*

Understanding the Shared Worker Lifecycle

A shared worker's lifecycle has the same stages and features of a dedicated worker. The difference is that, while a dedicated worker is inextricably bound to a single page, a shared worker will persist as long as a context remains connected to it.

Consider the following script, which creates a dedicated worker each time it is executed:

```
new Worker('./worker.js');
```

The following table details what happens when three tabs that spawn workers are opened and closed in sequence.

EVENT	RESULT	TOTAL WORKERS AFTER EVENT
Tab 1 executes <code>main.js</code>	Dedicated worker 1 spawned	1
Tab 2 executes <code>main.js</code>	Dedicated worker 2 spawned	2
Tab 3 executes <code>main.js</code>	Dedicated worker 3 spawned	3
Tab 1 closed	Dedicated worker 1 terminated	2
Tab 2 closed	Dedicated worker 2 terminated	1
Tab 3 closed	Dedicated worker 3 terminated	0

As shown in the table, parity exists between the number of times the script is executed, the number of open tabs, and the number of running workers. Next, consider the following trivial script, which creates or connects to a shared worker each time it is executed:

```
new SharedWorker('./sharedWorker.js');
```

The following table details what happens when three tabs are opened and closed in sequence.

EVENT	RESULT	TOTAL WORKERS AFTER EVENT
Tab 1 executes <code>main.js</code>	Shared worker 1 spawned	1
Tab 2 executes <code>main.js</code>	Connects to shared worker 1	1
Tab 3 executes <code>main.js</code>	Connects to shared worker 1	1
Tab 1 closed	Disconnects from shared worker 1	1
Tab 2 closed	Disconnects from shared worker 1	1
Tab 3 closed	Disconnects from shared worker 1. No connections remain, so worker 1 is terminated.	0

As shown in this table, subsequently invoking `new SharedWorker()` in tab 2 and 3 will connect to the existing worker. As connections are added and removed from the worker, the total number of connections is tracked. When the number of connections goes to zero, the worker is terminated.

Importantly, there is no way to programmatically terminate a shared worker. You will notice that the `terminate()` method is absent from the `SharedWorker` object. Furthermore, calling `close()` on a shared worker port (discussed later in the chapter) will not trigger the termination of the worker, even if there is only a single port connected to the worker.

A `SharedWorker` "connection" is uncorrelated with the connected state of an associated `MessagePort` or `MessageChannel`. As soon as a connection to a shared worker is established, the browser is responsible for managing that connection. The established connection will persist for the lifetime of the page, and only when the page is torn down and there are no further connections to a shared worker will the browser elect to terminate the worker.

Connecting to a Shared Worker

A `connect` event is fired inside a shared worker each time the `SharedWorker` constructor is called, whether or not a worker was created. This is demonstrated in the following example, where the constructor is called inside a loop:

SHAREDWORKER.JS

```
let i = 0;
self.onconnect = () => console.log(`connected ${++i} times`);
```

MAIN.JS

```

for (let i = 0; i < 5; ++i) {
  new SharedWorker('./sharedWorker.js');
}

// connected 1 times
// connected 2 times
// connected 3 times
// connected 4 times
// connected 5 times

```

Upon a connect event, the `SharedWorker` constructor implicitly creates a `MessageChannel` and passes ownership of a `MessagePort` unique to that instance of `SharedWorker`. This `MessagePort` is available inside the `connect` event object as the `ports` array. Because a connect event will only ever represent a single connection, you can safely assume that the `ports` array will have a length of exactly 1.

The following demonstrates accessing the event's `ports` array. Here, a `Set` is used to ensure that only unique object instances are tracked:

SHAREDWORKER.JS

```

const connectedPorts = new Set();

self.onconnect = ({ports}) => {
  connectedPorts.add(ports[0]);

  console.log(`${connectedPorts.size} unique connected ports`);
};

```

MAIN.JS

```

for (let i = 0; i < 5; ++i) {
  new SharedWorker('./sharedWorker.js');
}

// 1 unique connected ports
// 2 unique connected ports
// 3 unique connected ports
// 4 unique connected ports
// 5 unique connected ports

```

Importantly, shared workers behave asymmetrically in terms of setup and teardown. Each new `SharedWorker` connection triggers an event, but there is no corresponding event for when a `SharedWorker` instance disconnects (such as when a page is closed).

In the previous example, as pages connect and disconnect to the same shared worker, the `connectedPorts` collection will become polluted with dead ports with no way to identify them. One solution to this problem is to send an explicit teardown message right as the page is about to be destroyed at the `beforeunload` event, and to allow the shared worker to clean up.

SERVICE WORKERS

A *service worker* is a type of web worker that behaves like a proxy server inside the browser. Service workers allow you to intercept outgoing requests and cache the response. This allows a web page to work without network connectivity, as some or all of the page can potentially be served from the service worker cache. A service worker can also make use of the Notifications API, the Push API, the Background Sync API, and the Channel Messaging API.

Like shared workers, multiple pages on a single domain will all interact with a single service worker instance. However, to enable features such as the Push API, service workers can also survive the associated tab or browser being closed and wait for an incoming push event.

Ultimately, most developers will find that service workers are most useful for two primary tasks: acting as a caching layer for network requests, and enabling push notifications. In this sense, the service worker is a tool designed to enable web pages to behave like native applications.

NOTE *The service worker is an incredibly broad topic that could nearly fill an entire book of its own. To extend your understanding beyond this chapter, consider taking the Udacity course “Offline Web Applications” (<https://www.udacity.com/course/offline-web-applications--ud899>). Furthermore, Mozilla maintains a service worker cookbook site (<https://serviceworker.rs/>), which is an excellent reference for common service worker patterns.*

NOTE *The service worker lifecycle is heavily dependent on the number of open tabs on the same origin (referred to as “clients”), whether the page has undergone a navigation event, and whether the service worker script has changed (among many other factors). Some examples in the “Service Workers” section may not behave as expected if you do not have a good understanding of the service worker lifecycle. The section “Understanding the Service Worker Lifecycle” sheds light on what is happening under the hood.*

Furthermore, be wary of using the browser’s hard refresh feature (Ctrl+Shift+R) when dealing with service workers. A hard refresh will force the browser to ignore all network caches, and a service worker is considered by most major browsers to be a network cache.

Service Worker Basics

As a class of web worker, a service worker exhibits many of the same rhythms as a dedicated or shared worker. It exists in a totally separate execution context and can only be interacted with via asynchronous messaging. However, there are a number of fundamental differences between service and dedicated/shared.

The ServiceWorkerContainer

Service workers are different from dedicated and shared workers in that they have no global constructor. Instead, a service worker is managed through the `ServiceWorkerContainer`, available via `navigator.serviceWorker`. This object is the top-level interface, which allows you to direct the browser to create, update, destroy, or interact with a service worker.

```
console.log(navigator.serviceWorker);  
// ServiceWorkerContainer { ... }
```

Creating a Service Worker

Service workers are similar to shared workers in that a new one will be spawned if it does not yet exist; otherwise a connection is obtained to an existing one. Instead of creation through a global constructor, the `ServiceWorkerContainer` exposes a `register()` method, which is passed a script URL in the same fashion as the `Worker` or `SharedWorker` constructors:

EMPTYSERVICEWORKER.JS

```
// empty service worker script
```

MAIN.JS

```
navigator.serviceWorker.register('./emptyServiceWorker.js');
```

The `register()` method returns a promise, which resolves to a `ServiceWorkerRegistration` object or rejects if registration fails.

EMPTYSERVICEWORKER.JS

```
// empty service worker script
```

MAIN.JS

```
// Successfully registers a service worker, resolves  
navigator.serviceWorker.register('./emptyServiceWorker.js')  
  .then(console.log, console.error);
```

```
// ServiceWorkerRegistration { ... }
```

```
// Attempts to register service worker from nonexistent file, rejects  
navigator.serviceWorker.register('./doesNotExist.js')  
  .then(console.log, console.error);
```

```
// TypeError: Failed to register a ServiceWorker:  
// A bad HTTP response code (404) was received when fetching the script.
```

The nature of service workers allows you some flexibility with respect to choosing when to begin the registration. Once a service worker is activated after the initial `register()`, subsequent calls to `register()` on the same page and with the same URL are effectively a no-op. Furthermore, even though service workers are not globally supported by browsers, a service worker should be effectively invisible to the page because its proxy-like behavior means actions that would otherwise be handled will merely be dispatched to the network as normal.

Because of the aforementioned properties, an extremely common pattern for service worker registration is to gate it behind feature detection *and* the page's `load` event. This frequently appears as follows:

```
if ('serviceWorker' in navigator) {
  window.addEventListener('load', () => {
    navigator.serviceWorker.register('./serviceWorker.js');
  });
}
```

Without the `load` event gating, the service worker's registration will overlap with loading of page resources, which may slow the overall initial page render. Unless the service worker is responsible for managing cache behavior, which *must* occur as early as possible in the page setup process (such as when using `clients.claim()`, discussed later in the chapter), waiting for the `load` event is usually a sensible choice that still allows the page to enjoy all the benefits of using service workers.

Using the ServiceWorkerContainer Object

The `ServiceWorkerContainer` interface is the top-level wrapper for the browser's service worker ecosystem. It provides facilities for managing service worker state and lifecycle.

The `ServiceWorkerContainer` is always accessible in the client context:

```
console.log(navigator.serviceWorker);

// ServiceWorkerContainer { ... }
```

A `ServiceWorkerContainer` supports the following event handlers:

- **oncontrollerchange**—Can be assigned an event handler that will be called whenever a `controllerchange` event is emitted from the `ServiceWorkerContainer`.
 - This event occurs when a new activated `ServiceWorkerRegistration` is acquired.
 - This event can also be handled using `navigator.serviceWorker.addEventListener('controllerchange', handler)`.
- **onerror**—Can be assigned an event handler that will be called whenever an `ErrorEvent` of type `error` bubbles from any associated service worker.
 - This event occurs when an error is thrown inside any associated service worker.
 - This event can also be handled using `navigator.serviceWorker.addEventListener('error', handler)`.
- **onmessage**—Can be assigned an event handler that will be called whenever a `MessageEvent` of type `message` is sent from the service worker.
 - This event occurs when the service worker script sends a message event back to the parent context.
 - This event can also be handled using `navigator.serviceWorker.addEventListener('message', handler)`.

A `ServiceWorkerContainer` supports the following properties:

- **ready**—Returns a promise, which might resolve with an activated `ServiceWorkerRegistration` object. This promise will never reject.
- **controller**—Returns the activated `ServiceWorker` object associated with the current page, or null if there is no active service worker.

A `ServiceWorkerContainer` supports the following methods:

- **register()**—Creates or updates a `ServiceWorkerRegistration` using the provided `url` and `options` object.
- **getRegistration()**—Returns a promise, which will resolve with a `ServiceWorkerRegistration` object that matches the provided `scope`, or resolve with `undefined` if there is no matching service worker.
- **getRegistrations()**—Returns a promise, which will resolve with an array of all `ServiceWorkerRegistration` objects that are associated with the `ServiceWorkerContainer`, or an empty array if there are no associated service workers.
- **startMessage()**—Starts the transmission of message dispatches via `Client.postMessage()`.

Using the ServiceWorkerRegistration Object

The `ServiceWorkerRegistration` object represents a successful registration of a service worker. The object is available inside the resolved promise handler returned from `register()`. This object allows you to determine the lifecycle status of the associated service worker via several properties.

The registration object is provided inside a promise after `navigator.serviceWorker.register()` is called. Multiple calls on the same page with the same URL will return the same registration object.

```
navigator.serviceWorker.register('./serviceWorker.js')
  .then((registrationA) => {
    console.log(registrationA);

    navigator.serviceWorker.register('./serviceWorker2.js')
      .then((registrationB) => {
        console.log(registrationA === registrationB);
      });
  });
```

A `ServiceWorkerRegistration` supports the following event handler:

- **onupdatefound** can be assigned an event handler, which will be called whenever an event of type `updatefound` is fired from the service worker.
 - This event occurs when a new version of this service worker begins installation, signified by `ServiceWorkerRegistration.installing` acquiring a new service worker.
 - This event can also be handled using `serv.serviceWorkerRegistration.addEventListener('updatefound', handler)`.

A `ServiceWorkerRegistration` supports the following general properties:

- **scope**—Returns the full URL path of the service worker’s scope. This value is derived from the path from which the service worker’s script was retrieved and/or the scope provided inside `register()`.
- **navigationPreload**—Returns the `NavigationPreloadManager` instance associated with this registration object.
- **pushManager**—Returns the `PushManager` instance associated with this registration object.

A `ServiceWorkerRegistration` also supports the following properties, which can be used to inspect service workers at various stages of their lifecycles:

- **installing**—Returns the service worker with a state of `installing` if there is currently one, else `null`.
- **waiting**—Returns the service worker with a state of `waiting` if there is currently one, else `null`.
- **active**—Returns the service worker with a state of `activating` or `active` if there is currently one, else `null`.

Note that these properties are a one-time snapshot of the state of a service worker. These are suitable for most use cases, as an active service worker will not change state over the lifetime of a page unless coerced to do so with something like `ServiceWorkerGlobalScope.skipWaiting()`.

A `ServiceWorkerRegistration` supports the following methods:

- **getNotifications()**—Returns a promise, which resolves with an array of `Notification` objects.
- **showNotifications()**—Displays a notification configurable with a `title` and `options` arguments.
- **update()**—Re-requests the service worker script directly from the server and initiates fresh installation if the new script differs.
- **unregister()**—Will attempt to un-register a service worker registration. This allows service worker execution to complete before performing the unregistration.

Using the ServiceWorker Object

The `ServiceWorker` object can be obtained in one of two ways: via the `controller` property on the `ServiceWorkerController` object, and the `active` property on the `ServiceWorkerRegistration` object. This object inherits from the `Worker` prototype, and therefore offers all its properties and methods, but notably absent is the `terminate()` method.

A `ServiceWorker` supports the following event handler:

- **onstatechange** can be assigned an event handler that will be called whenever a state-change event is emitted from the `ServiceWorker`.

- This event occurs when `ServiceWorker.state` changes.
- This event can also be handled using `serviceWorker.addEventListener('statechange', handler)`.

A `ServiceWorker` supports the following properties:

- **scriptURL**—The resolved URL used to register the service worker. For example, if the service worker was created with the relative path `./serviceWorker.js`, then if it were registered on `https://www.example.com` the `scriptURL` property would return `https://www.example.com/serviceWorker.js`.
- **state**—Returns a string identifying the state of the service worker. The possible states are as follows:
 - `installing`
 - `installed`
 - `activating`
 - `activated`
 - `redundant`

Service Worker Security Restrictions

As a class of web worker, service workers are subject to the normal restrictions with respect to origin matching of the loaded script. (See the section “Worker Security Restrictions” earlier in the chapter for details on this.) Additionally, because service workers are granted nearly unlimited power to modify and redirect network requests and loaded static resources, the service worker API is only available in secure `https` contexts; in `http` contexts, `navigator.serviceWorker` will be `undefined`. To allow for ease of development, browsers make an exemption to the secure context rule for pages loaded locally, either via `localhost` or `127.0.0.1`.

NOTE *A handy tool for assessing if the current context is secure is `window.isSecureContext`.*

The `ServiceWorkerGlobalScope`

Inside the service worker, the global scope is an instance of `ServiceWorkerGlobalScope`. This inherits from `WorkerGlobalScope` and therefore includes all its properties and methods. A service worker is able to access this global scope via `self`.

`ServiceWorkerGlobalScope` extends the `WorkerGlobalScope` with the following properties and methods:

- **caches**—Returns the service worker’s `CacheStorage` object.
- **clients**—Returns the service worker’s `Clients` interface. Used to access underlying `Client` objects.

- **registration**—Returns the service worker’s `ServiceWorkerRegistration` object.
- **skipWaiting()**—Forces the service worker into an active state. This is used in conjunction with `Clients.claim()`.
- **fetch()**—Performs a normal fetch from inside the service worker. This is used when the service worker determines that an actual outgoing network request should be made (instead of returning a cached value).

Whereas dedicated or shared workers have only a `message` event as an input, service workers are able to consume a large number of events, which are triggered by actions on the page, notification actions, or push events.

NOTE *Depending on the browser implementation, logging to console inside the `SharedWorker` may not print in the default browser console view.*

A service worker’s global scope can listen for the following events, broken down here by category:

Service worker state

- **install** is fired when the service worker enters the *installing* state (visible in the client via `ServiceWorkerRegistration.installing`). You can also set a handler for this event on `self.oninstall`.
 - This is the first event received by a service worker and is fired as soon as worker execution begins.
 - Called only once per service worker.
- **activate** is fired when the service worker enters the *activating* or *activated* state (visible in the client via `ServiceWorkerRegistration.active`). You can also set a handler for this event on `self.onactivate`.
 - This event is fired when the service worker is ready to handle functional events and control clients.
 - This event does *not* mean that the service worker is controlling a client, only that it is prepared to do so.

Fetch API

- **fetch** is fired when the service worker intercepts a `fetch()` called in the main page. The service worker’s `fetch` event handler has access to the `FetchEvent` and can adjust the outcome as it sees fit. You can also set a handler for this event on `self.onfetch`.

Message API

- **message** is fired when the service worker receives data via `postMessage()`. You can also set a handler for this event on `self.onmessage`.

- Notification API.
- `notificationclick` is fired when the system reports to the browser that a notification spawned by `ServiceWorkerRegistration.showNotification()` was clicked. You can also set a handler for this event on `self.onnotificationclick`.
- `notificationclose` is fired when the system reports to the browser that a notification spawned by `ServiceWorkerRegistration.showNotification()` was closed or dismissed. You can also set a handler for this event on `self.onnotificationclose`.

Push API

- `push` is fired when the service worker receives a push message. You can also set a handler for this event on `self.onpush`.
- `pushsubscriptionchange` is fired when there is a change in push subscription state that occurred outside the control of the application (not explicitly in JavaScript). You can also set a handler for this event on `self.onpushsubscriptionchange`.

NOTE *Some browsers also support a `sync` event, which is part of the Background Sync API. This API is not standardized and only currently supported on Chrome and Opera. Therefore, it is not included in this book.*

Service Worker Scope Limitations

Service workers will only intercept requests from clients that are inside the service worker's *scope*. The scope is defined relative to the path from which the service worker's script was served. If not specified inside `register()`, the scope becomes the path to the service worker script.

(All the service worker registrations in these examples use absolute URLs for the script to avoid path confusion.) This first example demonstrates a default root scope for a worker script served from the root path:

```
navigator.serviceWorker.register('/serviceWorker.js')
  .then((serviceWorkerRegistration) => {
    console.log(serviceWorkerRegistration.scope);
    // https://example.com/
  });

// All of the following would be intercepted:
// fetch('/foo.js');
// fetch('/foo/fooScript.js');
// fetch('/baz/bazScript.js');
```

The following example demonstrates a same-directory scope for a worker script served from the root path:

```
navigator.serviceWorker.register('/serviceWorker.js', {scope: './'})
  .then((serviceWorkerRegistration) => {
    console.log(serviceWorkerRegistration.scope);
```

```

    // https://example.com/
  });

  // All of the following would be intercepted:
  // fetch('/foo.js');
  // fetch('/foo/fooScript.js');
  // fetch('/baz/bazScript.js');

```

The following example demonstrates a restricted scope for a worker script served from the root path:

```

navigator.serviceWorker.register('/serviceWorker.js', {scope: './foo'})
  .then((serviceWorkerRegistration) => {
    console.log(serviceWorkerRegistration.scope);
    // https://example.com/foo/
  });

  // All of the following would be intercepted:
  // fetch('/foo/fooScript.js');

  // All of the following would not be intercepted:
  // fetch('/foo.js');
  // fetch('/baz/bazScript.js');

```

The following example demonstrates a same-directory scope for a worker script served from a nested path:

```

navigator.serviceWorker.register('/foo/serviceWorker.js')
  .then((serviceWorkerRegistration) => {
    console.log(serviceWorkerRegistration.scope);
    // https://example.com/foo/
  });

  // All of the following would be intercepted:
  // fetch('/foo/fooScript.js');

  // All of the following would not be intercepted:
  // fetch('/foo.js');
  // fetch('/baz/bazScript.js');

```

The service worker scope effectively follows a directory permissions model in that it is only possible to reduce the scope of the service worker relative to where the file was served from. Attempting to expand the scope as follows throws an error:

```

navigator.serviceWorker.register('/foo/serviceWorker.js', {scope: '/'});

// Error: The path of the provided scope 'https://example.com/'
// is not under the max scope allowed 'https://example.com/foo/'

```

Typically, service worker scope will be defined as an absolute path with a trailing slash, as follows:

```

navigator.serviceWorker.register('/serviceWorker.js', {scope: '/foo/'})

```

This style of scope path definition accomplishes two tasks: it decouples the relative path of the script file from the relative scope path, and it prevents the path itself from being included in the scope. For example, in the preceding code snippet, it is probably undesirable for the `/foo` path to be included in the service worker scope; appending a trailing `/` will explicitly exclude the `/foo` path. Of course, this requires that the absolute scope path does not expand outside the service worker path.

If you wish to expand the scope of the service worker, there are two primary ways of doing so:

- Serve the service worker script from a path that encompasses the desired scope.
- Add a `Service-Worker-Allowed` header to the service worker script response with its value set to the desired scope. This scope value should match the scope value inside `register()`.

The Service Worker Cache

Before service workers, web pages lacked a robust mechanism for caching network requests. Browsers have always made use of an HTTP cache, but this has no programmatic interface available inside JavaScript, and its behavior is governed outside the JavaScript runtime. It was possible to develop an ad-hoc caching mechanism, which cached the response string or blob, but such strategies were messy and inefficient.

JavaScript cache implementations have been tried before. The MDN docs describe it marvelously:

The previous attempt—AppCache—seemed to be a good idea because it allowed you to specify assets to cache really easily. However, it made many assumptions about what you were trying to do and then broke horribly when your app didn't follow those assumptions exactly.

One of the major features of service workers is a true network request caching mechanism that can be programmatically managed. Unlike the HTTP cache or a CPU cache, the service worker cache is fairly primitive:

- **The service worker cache does not cache any requests automatically.** All cache entries must be explicitly added.
- **The service worker cache has no concept of time-based expiration.** A cache entry will remain cached unless explicitly removed.
- **Service worker cache entries must be manually updated and deleted.**
- **Caches must be manually versioned.** Each time a service worker updates, the new service worker is responsible for providing a fresh cache key to store new cache entries.
- **The only browser-enforced eviction policy is based on storage available for the service worker cache to use.** The service worker is responsible for managing the amount of space its cache uses. When the size of the cache exceeds browser limits, the browser will utilize a *least recently used* (LRU) eviction policy to make room for new cache entries.

At its core, the service worker cache mechanism is a two-tier dictionary in which each entry in the top-level dictionary maps to a second nested dictionary. The top-level dictionary is the `CacheStorage` object, which is available on the global scope of a service worker via the `caches` property. Each value in this top-level dictionary is a `Cache` object, which is a dictionary of `Request` objects mapping to `Response` objects.

As with `LocalStorage`, `Cache` objects inside `CacheStorage` persist indefinitely and will survive past the end of a browser session. Furthermore, `Cache` entries are only accessible on a per-origin basis.

NOTE *Although the `CacheStorage` and `Cache` objects are defined inside the Service Worker specification, they can be used by the main page or other types of web workers.*

The `CacheStorage` Object

The `CacheStorage` object is a key-value store of string keys mapping to `Cache` objects. The `CacheStorage` object features an API that resembles an asynchronous `Map`. The `CacheStorage` interface is available on the global object via its `caches` property.

```
console.log(caches); // CacheStorage {}
```

Individual caches inside `CacheStorage` are retrieved by passing their string key to `caches.open()`. Non-string keys are converted to a string. If the cache does not yet exist, it will be created.

The `Cache` object is returned in a promise:

```
caches.open('v1').then(console.log);

// Cache {}
```

Similar to a `Map`, `CacheStorage` features `has()`, `delete()`, and `keys()` methods. These methods all behave as promise-based analogues of their `Map` counterparts:

CACHESTORAGEEXAMPLE01.JS

```
// open a new v1 cache,
// check for the v1 cache,
// check for the nonexistent v2 cache

caches.open('v1')
  .then(() => caches.has('v1'))
  .then(console.log) // true
  .then(() => caches.has('v2'))
  .then(console.log); // false
```

CACHESTORAGEEXAMPLE02.JS

```
// open a new v1 cache,
// check for the v1 cache,
// delete the v1 cache,
// check again for the deleted v1 cache

caches.open('v1')
  .then(() => caches.has('v1'))
  .then(console.log) // true
  .then(() => caches.delete('v1'))
  .then(() => caches.has('v1'))
  .then(console.log); // false
```

CACHESTORAGEEXAMPLE03.JS

```
// open a v1, v3, and v2 cache
// check keys of current caches
// NOTE: cache keys are printed in creation order

caches.open('v1')
  .then(() => caches.open('v3'))
  .then(() => caches.open('v2'))
  .then(() => caches.keys())
  .then(console.log); // ["v1", "v3", "v2"]
```

The `CacheStorage` interface also features a `match()` method that can be used to check a `Request` object against *all* `Cache` objects in `CacheStorage`. The `Cache` objects are checked in `CacheStorage.keys()` order, and the first match is the response returned:

CACHESTORAGEEXAMPLE04.JS

```
// Create one request key and two response values
const request = new Request('');
const response1 = new Response('v1');
const response2 = new Response('v2');

// Use same key in both caches. v1 is found first since it has
// caches.keys() order priority
caches.open('v1')
  .then((v1cache) => v1cache.put(request, response1))
  .then(() => caches.open('v2'))
  .then((v2cache) => v2cache.put(request, response2))
  .then(() => caches.match(request))
  .then((response) => response.text())
  .then(console.log); // v1
```

`CacheStorage.match()` can be configured using an options object. This object is detailed in the following section, “The Cache Object.”

The Cache Object

A `CacheStorage` maps strings to `Cache` objects. `Cache` objects behave similarly to `CacheStorage` in that they, too, resemble an asynchronous `Map`. `Cache` keys can either be a URL string or a `Request` object; these keys will map to `Response` object values.

The service worker cache is intended to only cache GET http requests. This should make sense: this HTTP method implies that the response will not change over time. On the other hand, request methods such as POST, PUT, and DELETE are, by default, disallowed by the `Cache`. They imply a dynamic exchange with the server and therefore are unsuitable for caching by the client.

To populate a `Cache`, you have three methods at your disposal:

- **put(request, response)**—Used when you already have both the key (a `Request` object or URL string) and value (`Response` object) pair and wish to add the cache entry. This method returns a promise, which resolves when the cache entry is successfully added.

- **add(request)**—Used when you have only a `Request` object or URL. `add()` will dispatch a `fetch()` to the network and cache the response. This method returns a promise, which resolves when the cache entry is successfully added.
- **addAll(requests)**—Used when you wish to perform an all-or-nothing bulk addition to the cache—for example, the initial population of the cache when the service worker initializes. The method accepts an array of URLs or `Request` objects. `addAll()` performs an `add()` operation for each entry in the `requests` array. This method returns a promise, which resolves only when every cache entry is successfully added.

Similar to a `Map`, `Cache` features `delete()` and `keys()` methods. These methods all behave as promise-based analogues of their `Map` counterparts:

```
const request1 = new Request('https://www.foo.com');
const response1 = new Response('fooResponse');

caches.open('v1')
  .then((cache) => {
    cache.put(request1, response1)
      .then(() => cache.keys())
      .then(console.log) // [Request]
      .then(() => cache.delete(request1))
      .then(() => cache.keys())
      .then(console.log); // []
  });
```

To check a `Cache`, you have two methods at your disposal:

- **matchAll(request, options)**—Returns a promise, which resolves to an array of matching cache `Response` objects.
- This method is useful in scenarios where you wish to perform a bulk action upon similarly organized cache entries, such as deleting all the cached values inside the `/images` directory.
- The request matching schema can be configured via an options object, described later in this section.
- **match(request, options)**—Returns a promise, which resolves to a matching cache `Response` object, or `undefined` if there are no cache hits.
- This is essentially equivalent to `matchAll(request, options)[0]`.
- The request matching schema can be configured via an options object, described later in this section.

Cache hits are determined by matching URL strings and/or `Request` URLs. URL strings and `Request` objects are interchangeable, as the match is determined by extracting the `Request` object's URL. This interchangeability is demonstrated here:

```
const request1 = 'https://www.foo.com';
const request2 = new Request('https://www.bar.com');
```

```

const response1 = new Response('fooResponse');
const response2 = new Response('barResponse');

caches.open('v1').then((cache) => {
  cache.put(request1, response1)
  .then(() => cache.put(request2, response2))
  .then(() => cache.match(new Request('https://www.foo.com')))
  .then((response) => response.text())
  .then(console.log) // fooResponse
  .then(() => cache.match('https://www.bar.com'))
  .then((response) => response.text())
  .then(console.log); // barResponse
});

```

The Cache object makes use of the Request and Response objects' `clone()` method to create duplicates and store them as the key-value pair. This is demonstrated here, where the retrieved instances do not match the original key-value pair:

```

const request1 = new Request('https://www.foo.com');
const response1 = new Response('fooResponse');

caches.open('v1')
  .then((cache) => {
    cache.put(request1, response1)
    .then(() => cache.keys())
    .then((keys) => console.log(keys[0] === request1)) // false
    .then(() => cache.match(request1))
    .then((response) => console.log(response === response1)); // false
  });

```

`Cache.match()`, `Cache.matchAll()`, and `CacheStorage.matchAll()` all support an optional options object, which allows you to configure how the URL matching behaves by setting the following properties:

- **cacheName**—Only supported by `CacheStorage.matchAll()`. When set to a string, it will only match cache values inside the Cache keyed by the provided string.
- **ignoreSearch**—When set to `true`, directs the URL matcher to ignore query strings, both in the request query and the cache key. For example, `https://example.com?foo=bar` and `https://example.com` would match.
- **ignoreMethod**—When set to `true`, directs the URL matcher to ignore the http method of the request query. Consider the following example where a POST request can be matched to a GET:

```

const request1 = new Request('https://www.foo.com');
const response1 = new Response('fooResponse');

const postRequest1 = new Request('https://www.foo.com',
  { method: 'POST' });

caches.open('v1')
  .then((cache) => {
    cache.put(request1, response1)
    .then(() => cache.match(postRequest1))

```

```

    .then(console.log) // undefined
    .then(() => cache.match(postRequest1, { ignoreMethod: true }))
    .then(console.log); // Response {}
  });

```

- **ignoreVary**—The Cache matcher respects the Vary HTTP header, which specifies which request headers may cause the server response to differ. When `ignoreVary` is set to `true`, this directs the URL matcher to ignore the Vary header when matching.

```

const request1 = new Request('https://www.foo.com');
const response1 = new Response('fooResponse',
  { headers: { 'Vary': 'Accept' } });

const acceptRequest1 = new Request('https://www.foo.com',
  { headers: { 'Accept': 'text/json' } });

caches.open('v1')
  .then((cache) => {
    cache.put(request1, response1)
    .then(() => cache.match(acceptRequest1))
    .then(console.log) // undefined
    .then(() => cache.match(acceptRequest1, { ignoreVary: true }))
    .then(console.log); // Response {}
  });

```

Maximum Cache Storage

Browsers need to restrict the amount of storage any given cache is allowed to use; otherwise, unlimited storage would surely be subject to abuse. This storage limit does not follow any formal specification; it is entirely subject to the individual browser vendor's preference.

Using the `StorageEstimate` API, it is possible to determine approximately how much space is available (in bytes) and how much is currently used. This method is only available in a secure browser context:

```

navigator.storage.estimate()
  .then(console.log);

// Your browser's output will differ:
// { quota: 2147483648, usage: 590845 }

```

Per the service worker specification:

These are not exact numbers; between compression, deduplication, and obfuscation for security reasons, they will not be precise.

Service Worker Clients

A service worker tracks an association with a window, worker, or service worker with a `Client` object. Service workers can access these `Client` objects via the `Clients` interface, available on the global object via the `self.clients` property.

A `Client` object features the following properties and methods:

- **id**—Returns the universally unique identifier for this client, such as `7e4248ec-b25e-4b33-b15f-4af8bb0a3ac4`. This can be used to retrieve a reference to the client via `Clients.get()`.
- **type**—Returns the type of the client as a string. Its value will be one of `window`, `worker`, or `sharedworker`.
- **url**—Returns the client's URL.
- **postMessage()**—Allows you to send targeted messaging to a single client.

The `Clients` interface allows you to access `Client` objects via `get()` and `matchAll()`, both of which use a promise to return results. `matchAll()` can also be passed an `options` object that supports the following properties:

- **includeUncontrolled**—When set to `true`, returns clients that are not yet controlled by this service worker. Defaults to `false`.
- **type**—When set to `window`, `worker`, or `sharedworker`, filters returned clients to only that type. Defaults to `all`, which returns all types of clients.

The `Clients` interface also provides two methods:

- **openWindow(url)**—Allows you to open a new window at the specified URL, effectively adding a new `Client` to this service worker. The new `Client` object is returned in a resolved promise. This method is useful when a notification is clicked; the service worker can detect the click event and open a window in response to that click.
- **claim()**—Will forcibly set this service worker to control all clients in its scope. This is useful when you do not wish to wait for a page reload for the service worker to begin managing the page.

Service Workers and Consistency

Service workers should be understood through the lens of their overall intended purpose: to enable web pages to emulate native application behavior. Behaving like a native application demands that service workers support *versioning*.

At a high level, service worker versioning ensures that there is *consistency* between how two web pages on the same origin operate at any given time. This consistency guarantee takes two primary forms:

- **Code consistency**—Web pages are not created from a single binary like a native application, but instead from many HTML, CSS, JavaScript, image, JSON, and really any type of file assets that a page might load. Web pages will commonly undergo incremental upgrades—versions—to add or modify behavior. If a web page loads 100 files in total, and the assets loaded are a mix of versions 1 and 2, the resulting behavior is completely unpredictable and likely incorrect. Service workers provide an enforcement mechanism to ensure that all concurrently running pages on the same origin are always built from assets from the same version.

- **Data consistency**—Web pages are not hermetic applications. They can read and write data on the local device via various browser APIs such as `LocalStorage` or `IndexedDB`. They can also send and receive data to remote APIs. The format that data is read or written in may change between versions. If one page writes data in a version 1 format, but a second page attempts to read data in a version 2 format, the resulting behavior is completely unpredictable and likely incorrect. The service worker’s asset consistency mechanism also ensures that web page I/O behaves identically for all concurrently running pages on the same origin.

To preserve consistency, the service worker lifecycle goes to great lengths to avoid reaching a state that might compromise this consistency. For example:

- **Service workers fail early.** When attempting to install a service worker, any unexpected problem will prevent the service worker from being installed. This includes failing to load the service worker script, a syntax or runtime error in the service worker script, failing to load a worker dependency via `importScripts()`, or failing to load even a single cache asset.
- **Service workers aggressively update.** When the browser loads the service worker script again (either manually via `register()` or on a page reload), browsers will begin installation of a new service worker version if there is even a single byte of difference between the service worker script *or* any dependencies loaded via `importScripts()`.
- **Inactive service workers passively activate.** When `register()` is invoked for the first time on a page, the service worker is installed but will not be activated and begin to control the page until after a navigation event. This should make sense: the current page has presumably already loaded assets, so the service worker should not be activated and begin loading inconsistent assets.
- **Active service workers are sticky.** As long as there is at least one client associated with the active service worker, the browser will continue to use it for all pages of that origin. The browser can begin installation of a new service worker instance intended to replace the active one, but the browser will not switch to the new worker until there are 0 clients controlling the active one (or until the service worker is forcibly updated). This service worker eviction strategy prevents two clients from running two different service worker versions at once.

Understanding the Service Worker Lifecycle

The service worker specification defines six discrete states that a service worker might exist in: *parsed*, *installing*, *installed*, *activating*, *activated*, and *redundant*. A full lifecycle for a service worker will always visit these states in this order, although it may not visit every state. A service worker that encounters an error during installation or activation will skip to the *redundant* state.

Each state change will fire a `statechange` event on the `ServiceWorker` object. A handler can be set to listen for this event as follows:

```
navigator.serviceWorker.register('./serviceWorker.js')
  .then((registration) => {
    registration.installing.onstatechange = ({ target: { state } }) => {
      console.log('state changed to', state);
    };
  });
```

The Parsed State

A call to `navigator.serviceWorker.register()` will initiate the process of creating a service worker instance. The *parsed* state is assigned to that freshly created service worker. This state has no events or `ServiceWorker.state` value associated with it.

NOTE *Note that, although `parsed` is a formally defined state in the Service Worker specification, `ServiceWorker.prototype.state` will never return `parsed`. The earliest state that property can return is `installing`.*

The browser fetches the script file and performs some initial tasks to begin the lifecycle:

1. Ensure the service worker script is served on the same domain.
2. Ensure the service worker registration occurs inside a secure context.
3. Ensure the service worker script can be successfully parsed by the browser's JavaScript interpreter without throwing any errors.
4. Capture a snapshot of the service worker script. The next time the browser downloads the service worker script, it will diff it against this snapshot and use that to decide if it should update the service worker or not.

If all these succeed, the promise returned from `register()` will resolve with a `ServiceWorkerRegistration` object, and a newly created service worker instance proceeds to the *installing* state.

The Installing State

The *installing* state is where all service worker "setup" tasks should be performed. This includes work that must occur prior to the service worker controlling the page.

On the client, this phase can be identified by checking to see if the `ServiceWorkerRegistration.installing` property is set to a `ServiceWorker` instance:

```
navigator.serviceWorker.register('./serviceWorker.js')
  .then((registration) => {
    if (registration.installing) {
      console.log('Service worker is in the installing state');
    }
  });
```

The associated `ServiceWorkerRegistration` object will also fire the `updatefound` event any time a service worker reaches this state:

```
navigator.serviceWorker.register('./serviceWorker.js')
  .then((registration) => {
    registration.onupdatefound = () =>
      console.log('Service worker is in the installing state');
  });
```

In the service worker, this phase can be identified by setting a handler for the `install` event:

```
self.oninstall = (installEvent) => {
  console.log('Service worker is in the installing state');
};
```

The *installing* state is frequently used to populate the service worker's cache. The service worker can be directed to remain in the *installing* state until a collection of assets is successfully cached. If any of the assets fail to cache, the service worker will fail to install and will be sent to the *redundant* state.

The service worker can be held in the installing state by means of an `ExtendableEvent`. The `InstallEvent` inherits from `ExtendableEvent` and therefore exposes an API, which allows you to delay a state transition until a promise resolves. This is accomplished with the `ExtendableEvent.waitUntil()` method. This method expects to be passed a promise that will delay transitioning to the next state until that promise resolves. For example, the following example would delay transitioning to the *installed* state by five seconds:

```
self.oninstall = (installEvent) => {
  installEvent.waitUntil(
    new Promise((resolve, reject) => setTimeout(resolve, 5000))
  );
};
```

A more pragmatic use of this method would be to cache a group of assets via `Cache.addAll()`:

```
const CACHE_KEY = 'v1';

self.oninstall = (installEvent) => {
  installEvent.waitUntil(
    caches.open(CACHE_KEY)
      .then((cache) => cache.addAll([
        'foo.js',
        'bar.html',
        'baz.css',
      ]))
  );
};
```

If there is no error thrown or promise rejected, the service worker proceeds to the *installed* state.

The Installed State

The *installed* state, also referred to as the *waiting* state, indicates that the service worker has no additional setup tasks to perform and that it is prepared to assume control of clients once it is allowed to do so. If there is no active service worker, a freshly installed service worker will skip this state and proceed directly to the *activating* state since there is no reason to wait.

On the client, this phase can be identified by checking to see if the `ServiceWorkerRegistration.waiting` property is set to a `ServiceWorker` instance:

```
navigator.serviceWorker.register('./serviceWorker.js')
  .then((registration) => {
    if (registration.waiting) {
      console.log('Service worker is in the installing/waiting state');
    }
  });
```

If there is already an active service worker, the *installed* state can be the appropriate time to trigger logic, which will promote this new service worker to the *activating* state. This might take the form of forcibly promoting this service worker via `self.skipWaiting()`. It also might take the form of prompting the user to reload the application, thereby allowing the browser to organically promote the service worker.

The Activating State

The *activating* state indicates that the service worker has been selected by the browser to become the service worker that should control the page. If there is no incumbent active service worker in the browser, this new service worker will automatically reach the *activating* state. If, however, there is an incumbent active service worker, this new replacement service worker can reach the *activating* state in the following ways:

- **The number of clients controlled by the incumbent service worker goes to 0.** This often takes the form of all controlled browser tabs being closed. On the next navigation event, the new service worker will reach the *activating* state.
- **The *installed* service worker calls `self.skipWaiting()`.** This takes effect immediately and does not need to wait for a navigation event.

While in the *activating* state, no functional events such as `fetch` or `push` are dispatched until the service worker reaches the *activated* state.

On the client, this phase can be partially identified by checking to see if the `ServiceWorkerRegistration.active` property is set to a `ServiceWorker` instance:

```
navigator.serviceWorker.register('./serviceWorker.js')
  .then((registration) => {
    if (registration.active) {
      console.log('Service worker is in the activating/activated state');
    }
  });
```

Note that the `ServiceWorkerRegistration.active` property indicates that the service worker is in either the *activating* or *activated* state.

In the service worker, this phase can be identified by setting a handler for the `activate` event:

```
self.oninstall = (activateEvent) => {
  console.log('Service worker is in the activating state');
};
```

The `activate` event indicates that it is safe to clean up after the old service worker, and this event is frequently used to purge old cache data and migrate databases. For example, the following example purges all older cache versions:

```
const CACHE_KEY = 'v3';

self.oninstall = (activateEvent) => {
  caches.keys()
    .then((keys) => keys.filter((key) => key !== CACHE_KEY))
    .then((oldKeys) => oldKeys.forEach((oldKey) => caches.delete(oldKey)));
};
```

An activate event also inherits from `ExtendableEvent` and therefore also supports the `waitUntil()` convention for delaying a transition to the *activated* state—or transitioning to the *redundant* state upon a rejected promise.

NOTE *The active event in a service worker does not mean that this service worker is controlling clients.*

The Activated State

The *activated* state indicates that the service worker is in control of one or many clients. In this state, the service worker will capture `fetch()` events inside its scope as well as notification and push events.

On the client, this phase can be partially identified by checking to see if the `ServiceWorkerRegistration.active` property is set to a `ServiceWorker` instance:

```
navigator.serviceWorker.register('./serviceWorker.js')
  .then((registration) => {
    if (registration.active) {
      console.log('Service worker is in the activating/activated state!');
    }
  });
```

Note that the `ServiceWorkerRegistration.active` property indicates that the service worker is in either the *activating* or *activated* state.

A superior indication that a service worker is in the activated state is to check the `controller` property of the `ServiceWorkerRegistration`. This will return the activated `ServiceWorker` instance, which is controlling the page:

```
navigator.serviceWorker.register('./serviceWorker.js')
  .then((registration) => {
    if (registration.controller) {
      console.log('Service worker is in the activated state!');
    }
  });
```

When a new service worker takes control of a client, the `ServiceWorkerContainer` in that client will fire a `controllerchange` event:

```
navigator.serviceWorker.oncontrollerchange = () => {
  console.log('A new service worker is controlling this client!');
};
```

It's also possible to use the `ServiceWorkerContainer.ready` promise to detect an active service worker. This ready promise resolves once the current page has an active worker:

```
navigator.serviceWorker.ready.then(() => {
  console.log('A new service worker is controlling this client!');
});
```

The Redundant State

The *redundant* state is the graveyard for service workers. No events will be passed to it, and the browser is free to destroy it and free up its resources.

Updating a Service Worker

Because the concept of versioning is baked into service workers, they are expected to periodically change. Therefore, service workers feature a robust and intricate updating process for safely replacing an outdated active service worker.

This update process begins with an update check, where the browser re-requests the service worker script. A check for an update can be triggered by the following events:

- `navigator.serviceWorker.register()` is called with a different URL string than the currently active service worker.
- The browser navigates to a page inside the service worker's scope.
- A functional event such as `fetch` or `push` occurs *and* an update check has not occurred for at least 24 hours.

The freshly fetched service worker script is diffed against the incumbent service worker's script. If they are not identical, the browser initializes a new service worker with the new script. The updated service worker will proceed through its lifecycle until it reaches the *installed* state. Once it reaches the *installed* state, the updated service worker will wait until the browser decides it can safely obtain control of the page (or until the user forces it to take control of the page).

Importantly, refreshing a page will *not* allow the updated service worker to activate and replace the incumbent service worker. Consider a scenario where there is a single page open with an incumbent service worker controlling it and an updated service worker waiting in the *installed* state. Clients overlap during a page refresh—meaning the new page is loaded before the old page dies—and therefore the incumbent service worker never relinquishes control because it still controls a nonzero number of clients. Because of this, closing all controlled pages is the only way to allow the incumbent service worker to be replaced.

Inversion of Control and Service Worker Persistence

Whereas dedicated and shared workers are designed to be stateful, service workers are designed to be stateless. More specifically, service workers follow the Inversion of Control (IOC) pattern and are built to be event driven.

The primary implication of this is that service workers should have no reliance whatsoever on the global state of the worker. Nearly all code inside the service worker should be defined inside event handlers—the notable exception being global constants such as the service worker version. The number of times a service worker script will execute is wildly variable and highly dependent on browser state, and therefore the service worker script's behavior should be idempotent.

It's important to understand that the lifetime of a service worker is uncorrelated with the lifetime of the clients it is connected to. Most browsers implement service workers as a separate process, and

this process is independently managed by the browser. If a browser detects a service worker is idle, it can terminate the worker and restart it again when needed. This means that, while you can rely on a service worker to handle events once activated, you cannot rely on a service worker's persistent global state.

Managing Service Worker File Caching with `updateViaCache`

Normally, all JavaScript assets loaded by the browser are subject to the browser's HTTP cache as defined by their `Cache-Control` header. Because service worker scripts are not given preferential treatment, the browser will not receive updated service worker script updates until the cached file expires.

To propagate service worker updates as quickly as possible, a common solution is to serve service worker scripts with a `Cache-Control: max-age=0` header. With this, the browser will always fetch the most up-to-date script file.

This instant-expiry solution works well, but solely relying on HTTP headers to dictate service worker behavior means that only the *server* decides how the client should update. To allow the client agency over its updating behavior, the `updateViaCache` property exists to allow for control over how the client should treat service worker scripts. This property can be defined when registering the service worker, and it accepts three string values:

- `imports`: the default value. The top-level service worker script file will never be cached, but files imported inside the service worker via `importScripts()` will still be subject to the HTTP cache and `Cache-Control` header.
- `all`: No service worker scripts are given special treatment. All files are subject to the HTTP cache and `Cache-Control` header.
- `none`: Both the top-level service worker script and files imported inside the service worker via `importScripts()` will never be cached.

The `updateViaCache` property is used as follows:

```
navigator.serviceWorker.register('/serviceWorker.js', {  
  updateViaCache: 'none'  
});
```

Browsers are still in the process of moving to support this option, so it is strongly recommended that you use both `updateViaCache` and the `Cache-Control` header to dictate caching behavior on the client.

Forced Service Worker Operation

In some cases, it makes sense to coerce a service worker into the activated state as quickly as possible—even at the expense of potential asset versioning conflicts. This commonly takes the form of caching assets at the install event, forcing the service worker to activate, and then forcing the activated service worker to control the associated clients.

A basic version of this might appear as follows:

```
const CACHE_KEY = 'v1';

self.oninstall = (installEvent) => {
  // Populate the cache, then force the service worker
  // into the activated state. This triggers the 'activate' event.
  installEvent.waitUntil(
    caches.open(CACHE_KEY)
      .then((cache) => cache.addAll([
        'foo.css',
        'bar.js',
      ]))
      .then(() => self.skipWaiting())
  );
};

// Force the service worker to take control of the clients. This fires a
// controllerchange event on each client.
self.onactivate = (activateEvent) => clients.claim();
```

Browsers will check for a new service worker script on each navigation event, but sometimes this is too infrequent. The `ServiceWorkerRegistration` object features an `update()` method that can be used to instruct the browser to re-request the service worker script, compare it to the existing one, and begin installation of an updated service worker if necessary. This might be accomplished as follows:

```
navigator.serviceWorker.register('./serviceWorker.js')
  .then((registration) => {
    // Check for an updated version every ~17 minutes
    setInterval(() => registration.update(), 1E6);
  });
```

Service Worker Messaging

As with dedicated workers and shared workers, service workers are able to exchange asynchronous messages with clients using `postMessage()`. One of the simplest ways of accomplishing this is to send a message to the active worker and use the event object to send a reply. Messages sent to the service worker can be handled on the global scope, whereas messages sent back to the client can be handled on the `ServiceWorkerContext` object:

SERVICEWORKER.JS

```
self.onmessage = ({data, source}) => {
  console.log('service worker heard:', data);

  source.postMessage('bar');
};
```

MAIN.JS

```
navigator.serviceWorker.onmessage = ({data}) => {
  console.log('client heard:', data);
};
```

```

navigator.serviceWorker.register('./serviceWorker.js')
  .then((registration) => {
    if (registration.active) {
      registration.active.postMessage('foo');
    }
  });

// service worker heard: foo
// client heard: bar

```

This can just as easily use the `serviceWorker.controller` property:

SERVICWORKER.JS

```

self.onmessage = ({data, source}) => {
  console.log('service worker heard:', data);

  source.postMessage('bar');
};

```

MAIN.JS

```

navigator.serviceWorker.onmessage = ({data}) => {
  console.log('client heard:', data);
};

navigator.serviceWorker.register('./serviceWorker.js')
  .then(() => {
    if (navigator.serviceWorker.controller) {
      navigator.serviceWorker.controller.postMessage('foo');
    }
  });

// service worker heard: foo
// client heard: bar

```

The preceding examples will work every time the page reloads, as the service worker will reply to the new message sent from the client script after each reload. It will also work every time this page is opened in a new tab.

If, instead, the service worker should initiate the message handshake, a reference to the client can be obtained as follows:

SERVICWORKER.JS

```

self.onmessage = ({data}) => {
  console.log('service worker heard:', data);
};

self.onactivate = () => {
  self.clients.matchAll({includeUncontrolled: true})
    .then((clientMatches) => clientMatches[0].postMessage('foo'));
};

```

MAIN.JS

```

navigator.serviceWorker.onmessage = ({data, source}) => {
  console.log('client heard:', data);

  source.postMessage('bar');
};

navigator.serviceWorker.register('./serviceWorker.js')

// client heard: foo
// service worker heard: bar

```

The preceding example will only work once, as the active event is only fired a single time per service worker.

Because clients and service workers can send messages back and forth, it is also possible to set up a `MessageChannel` or `BroadcastChannel` to exchange messages.

Intercepting a fetch Event

One of the most important features of service workers is their ability to intercept network requests. A network request inside the scope of a service worker will register as a `fetch` event. This interception ability is not limited to the `fetch()` method; it also can intercept requests for JavaScript, CSS, images, and HTML—including the primary HTML document itself. These requests can come from JavaScript, or they can be requests created by tags such as `<script>`, `<link>`, or `` tags. Intuitively, this should make sense: for a service worker to emulate an offline web app, it must be able to account for all the requested assets needed for the page to function properly.

A `FetchEvent` inherits from `ExtendableEvent`. The valuable method that allows service workers to decide how to handle a `fetch` event is `event.respondWith()`. This method expects a promise, which should resolve with a `Response` object. Of course, your service worker gets to decide where this `Response` object actually comes from. It could be from the network, from the cache, or created on the fly. The following sections cover a handful of network/cache strategies to employ inside a service worker.

Return from Network

This strategy is a simple passthrough for a `fetch` event. A good use case for this might be any requests that definitely need to reach the server, such as a POST request. This strategy can be implemented as follows:

```

self.onfetch = (fetchEvent) => {
  fetchEvent.respondWith(fetch(fetchEvent.request));
};

```

NOTE *The preceding code is only to demonstrate how to use `event.respondWith()`. If `event.respondWith()` isn't called, the browser will send the request out to the network.*

Return from Cache

This strategy is a simple cache check. A good use case for this might be any requests that are guaranteed to be in the cache—such as assets cached during the installation phase.

```
self.onfetch = (fetchEvent) => {
  fetchEvent.respondWith(caches.match(fetchEvent.request));
};
```

Return from Network with Cache Fallback

This strategy gives preference to up-to-date responses from the network but will still return values in the cache if they exist. A good use case for this is when your application needs to show the most up-to-date information as often as possible, but would still like to show something if the application is offline.

```
self.onfetch = (fetchEvent) => {
  fetchEvent.respondWith(
    fetch(fetchEvent.request)
      .catch(() => caches.match(fetchEvent.request))
  );
};
```

Return from Cache with Network Fallback

This strategy gives preference to responses it can show more quickly but will still fetch from the network if a value is uncached. This is the superior fetch handling strategy for most progressive web applications.

```
self.onfetch = (fetchEvent) => {
  fetchEvent.respondWith(
    caches.match(fetchEvent.request)
      .then((response) => response || fetch(fetchEvent.request))
  );
};
```

Generic Fallback

Applications need to account for scenarios where both the cache and network fail to produce a resource. Service workers can handle this by caching fallback resources upon install and returning them when both cache and network fail.

```
self.onfetch = (fetchEvent) => {
  fetchEvent.respondWith(
```

```

    // Begin with 'Return from cache with network fallback' strategy
    caches.match(fetchEvent.request)
      .then((response) => response || fetch(fetchEvent.request))
      .catch(() => caches.match('/fallback.html'))
  );
};

```

The `catch()` clause can be extended to support many different types of fallbacks such as placeholder images, dummy data, and so on.

NOTE *The Google Developers site has a smashing article on network/caching strategies:* <https://developers.google.com/web/fundamentals/instant-and-offline/offline-cookbook>.

Push Notifications

For a web application to properly emulate a native application, it must be able to support push notifications. This means that a web page must be able to receive a push event from a server and display a notification on the device—even when the application is not running. With conventional web pages, this, of course is impossible, but the addition of service workers means that this behavior is now supported.

For push notifications to work in a progressive web application, four behavioral aspects must be supported:

- The service worker must be able to display notifications.
- The service worker must be able to handle interactions with those notifications.
- The service worker must be able to subscribe to server-sent push notifications.
- The service worker must be able to handle push messages, even when the application is not in the foreground or open.

Displaying Notifications

Service workers have access to the Notification API via their registration object. There is good reason for this: notifications associated with a service worker will also trigger interaction events inside that service worker.

Showing notifications requires explicit permission from the user. Once this is granted, notifications can be shown via `ServiceWorkerRegistration.showNotification()`. This can be accomplished as follows:

```

navigator.serviceWorker.register('./serviceWorker.js')
  .then((registration) => {
    Notification.requestPermission()
      .then((status) => {

```

```

    if (status === 'granted') {
      registration.showNotification('foo');
    }
  });
});

```

Similarly, a notification can be triggered from inside a service worker using the global `registration` property:

```
self.onactivate = () => self.registration.showNotification('bar');
```

In these examples, once notification permissions are granted, a `foo` notification is shown in the browser. This notification will be visually indistinguishable from one generated using `new Notification()`. Furthermore, it doesn't require the service worker to do any work for it to appear. The service worker comes into play when notification events are required.

Handling Notification Events

A notification created via a `ServiceWorkerRegistration` object will send `notificationclick` and `notificationclose` events to the service worker. Suppose the previous example's service worker script was defined as follows:

```

self.onnotificationclick = ({notification}) => {
  console.log('notification click', notification);
};

self.onnotificationclose = ({notification}) => {
  console.log('notification close', notification);
};

```

In this example, both types of interactions with a notification will register inside the service worker. The `notificationevent` exposes a `notification` property, containing the `Notification` object that generated the event. These event handlers can decide what to do after an interaction.

Frequently, clicking a notification means the user wishes to be taken to a specific view. Inside the service worker handler, this can be accomplished via `clients.openWindow()`, shown here:

```

self.onnotificationclick = ({notification}) => {
  clients.openWindow('https://foo.com');
};

```

Subscribing to Push Events

For push messages to be sent to a service worker, the subscription must happen via the service worker's `PushManager`. This will allow the service worker to handle push messages in a push event handler.

The subscription can be done using `ServiceWorkerRegistration.pushManager`, as shown here:

```

navigator.serviceWorker.register('./serviceWorker.js')
  .then((registration) => {
    registration.pushManager.subscribe({
      applicationServerKey: key, // derived from server's public key
      userVisibleOnly: true
    });
  });

```

Alternately, the service worker can subscribe itself using the global `registration` property:

```
self.onactivate = () => {
  self.registration.pushManager.subscribe({
    applicationServerKey: key, // derived from server's public key
    userVisibleOnly: true
  });
};
```

Handling Push Events

Once subscribed, the service worker will receive push events each time the server pushes a message. They can be handled as follows:

```
self.onpush = (pushEvent) => {
  console.log('Service worker was pushed data:', pushEvent.data.text());
};
```

To implement a true push notification, this handler only needs to create a notification via the registration object. However, a well-behaved push notification needs to keep the service worker that produced it alive long enough for its interaction event to be handled.

To accomplish this, the push event inherits from `ExtendableEvent`. The promise returned from `showNotification()` can be passed to `waitUntil()`, which will keep the service worker alive until the notification's promise resolves.

A simple push notification implementation might appear as follows:

MAIN.JS

```
navigator.serviceWorker.register('./serviceWorker.js')
.then((registration) => {
  // Request permission to show notifications
  Notification.requestPermission()
  .then((status) => {
    if (status === 'granted') {
      // Only subscribe to push messages if
      // notification permission is granted
      registration.pushManager.subscribe({
        applicationServerKey: key, // derived from server's public key
        userVisibleOnly: true
      });
    }
  });
});
```

SERVICWORKER.JS

```
// When a push event is received, display the data as text
// inside a notification.
self.onpush = (pushEvent) => {
  // Keep the service worker alive until notification promise resolves
  pushEvent.waitUntil(
    self.registration.showNotification(pushEvent.data.text())
  );
};
```

```
// When a notification is clicked, open relevant application page
self.onnotificationclick = ({notification}) => {
  clients.openWindow('https://example.com/clicked-notification');
};
```

SUMMARY

Workers allow you to run asynchronous JavaScript that will not block the user interface. This is very useful for complex calculations and data processing that would otherwise take up a lot of time and interfere with the user's ability to use the page. Workers are always given their own execution environment, and can only be communicated with via asynchronous messaging.

Workers can be dedicated, meaning they are associated with a single page, or shared, meaning that any page on the same origin can establish a connection with a single worker.

Service workers are designed to allow web pages to behave like native apps. Service workers are also a type of worker, but they behave more like a network proxy than a separate browser thread. They can behave as a highly customizable network cache, and they also can enable push notifications for progressive web applications.

28

Best Practices

WHAT'S IN THIS CHAPTER?

- Writing maintainable code
- Ensuring code performance
- Deploying code to production

WROX.COM DOWNLOADS FOR THIS CHAPTER

Please note that all the code examples for this chapter are available as a part of this chapter's code download on the book's website at www.wrox.com/go/projavascript4e on the Download Code tab.

The discipline of web development has grown at an extraordinary rate since 2000. What used to be a virtual Wild West, where just about anything was acceptable, has evolved into a complete discipline with research and established best practices. As simple websites grew into more complex web applications, and web hobbyists became paid professionals, the world of web development was filled with information about the latest techniques and development approaches. JavaScript, in particular, was the beneficiary of a lot of research and conjecture. Best practices for JavaScript fall into several categories and are handled at different points in the development process.

MAINTAINABILITY

In early websites, JavaScript was used primarily for small effects or form validation. Today's web applications are filled with thousands of lines of JavaScript executing all types of complicated processes. This evolution requires that developers take maintainability into account. As with software engineers in more traditional disciplines, JavaScript developers are hired to create value for their company, and they do that not just by delivering products on time but also by developing intellectual property that continues to add value long after.

Writing maintainable code is important because most developers spend a large amount of their time maintaining other people's code. It's a truly rare occurrence to be able to develop new code from scratch; it's often the case that you must build on work that someone else has done. Making sure that your code is maintainable ensures that other developers can perform their jobs as well as possible.

NOTE *Note that the concept of maintainable code is not unique to JavaScript. Some of these concepts apply broadly to any programming language, although there are some JavaScript-specific concepts as well.*

What Is Maintainable Code?

Maintainable code has several characteristics. In general, code is said to be maintainable when it is all of the following:

- **Understandable**—Someone else can pick up the code and figure out its purpose and general approach without a walk-through by the original developer.
- **Intuitive**—Things in the code just seem to make sense, no matter how complex the operation.
- **Adaptable**—The code is written in such a way that variation in data doesn't require a complete rewrite.
- **Extendable**—Care has been given in the code architecture to allow extension of the core functionality in the future.
- **Debuggable**—When something goes wrong, the code gives you enough information to identify the issue as directly as possible.

Being able to write maintainable JavaScript code is an important skill for professionals. This is the difference between hobbyists who hack together a site over the weekend and professional developers who really know their craft.

Code Conventions

One of the simplest ways to start writing maintainable code is to come up with code conventions for the JavaScript that you write. Code conventions have been developed for most programming languages, and a quick Internet search is likely to turn up thousands of documents. Professional organizations have long instituted code conventions for developers in an attempt to make code more maintainable for everyone. The best-run open-source projects have strict code convention requirements that allow everyone in the community to easily understand how code is organized.

Code conventions are important for JavaScript because of the language's adaptability. Unlike most object-oriented languages, JavaScript doesn't force developers into defining everything as objects. The language can support any number of programming styles, from traditional object-oriented approaches to declarative approaches to functional approaches. A quick review of several open-source JavaScript libraries can easily yield multiple approaches to creating objects, defining methods, and managing the environment.

The following sections discuss the basics of how to develop code conventions. These topics are important to address, although the way in which they are addressed may differ, depending on your individual needs.

Readability

For code to be maintainable, it must first be readable. Readability has to do with the way the code is formatted as a text file. A large part of readability has to do with the indentation of the code. When everyone is using the same indentation scheme, code across an entire project becomes much easier to read. Indentation is usually done by using a number of spaces instead of by using the tab character, which is typically displayed differently by different text editors. A good general indentation size is four spaces, although you may decide to use less or more.

Another part of readability is comments. In most programming languages, it's an accepted practice to comment each method. Because of JavaScript's ability to create functions at any point in the code, this is often overlooked. Because of this, it is perhaps even more important to document each function in JavaScript. Generally speaking, the places that should be commented in your code are as follows:

- **Functions and methods**—Each function or method should include a comment that describes its purpose and possibly the algorithm being used to accomplish the task. It's also important to state assumptions that are being made, what the arguments represent, and whether or not the function returns a value (since this is not discernible from a function definition).
- **Large sections of code**—Multiple lines of code that are all used to accomplish a single task should be preceded with a comment describing the task.
- **Complex algorithms**—If you're using a unique approach to solve a problem, explain how you are doing it as a comment. This will not only help others who are looking at your code but also help you the next time you look at it.
- **Hacks**—Because of browser differences, JavaScript code typically contains some hacks. Don't assume that someone else who is looking at the code will understand the browser issue that such a hack is working around. If you need to do something differently because one of the browsers can't use the normal way, put that in a comment. It reduces the likelihood that someone will come along, see your hack, and “fix” it, inadvertently introducing the bug that you had already worked around.

Indentation and comments create more readable code that is easier to maintain in the future.

Variable and Function Naming

The proper naming of variables and functions in code is vital to making it understandable and maintainable. Because many JavaScript developers began as hobbyists, there's a tendency to use nonsensical names such as `foo` and `bar` for variables and names such as `doSomething` for functions. A professional JavaScript developer must overcome these old habits to create maintainable code. General rules for naming are as follows:

- Variable names should be nouns, such as `car` or `person`.
- Function names should begin with a verb, such as `getName()`. Functions that return Boolean values typically begin with `is`, as in `isEnabled()`.

- Use logical names for both variables and functions, without worrying about the length. Length can be mitigated through postprocessing and compression (discussed later in this chapter).
- Variables, functions, and methods should begin with a lowercase letter and camelCase, such as `getName()` and `isPerson`. Classes like `Person` and `RequestFactory` should be capitalized. Constant values should be all uppercase and underscores, such as `REQUEST_TIMEOUT`.
- Be descriptive and sensible with names, but not too verbose. `getName()` intuitively will return a name value. `PersonFactory` will be producing some sort of `Person` object or entity.

It's imperative to avoid useless variable names that don't indicate the type of data they contain. With proper naming, code reads like a narrative of what is happening, making it easier to understand.

Variable Type Transparency

Because variables are loosely typed in JavaScript, it is easy to lose track of the type of data that a variable should contain. Proper naming mitigates this to some point, but it may not be enough in all cases. There are three ways to indicate the data type of a variable.

The first way is through initialization. When a variable is defined, it should be initialized to a value that indicates how it will be used in the future. For example, a variable that will hold a Boolean should be initialized to either `true` or `false`, and a variable to hold numbers should be initialized to a number, as in the following example:

```
// variable type indicated by initialization
let found = false;      // Boolean
let count = -1;        // number
let name = "";         // string
let person = null;     // object
```

Initialization to a particular data type is a good indication of a variable's type. The downside of initialization is that it cannot be used with function arguments in the function declaration.

The second way to indicate a variable's type is to use Hungarian notation. Hungarian notation prepends one or more characters to the beginning of a variable to indicate the data type. This notation is popular among scripted languages and was, for quite some time, the preferred format for JavaScript as well. The most traditional Hungarian notation format for JavaScript prepends a single character for the basic data types: "o" for objects, "s" for strings, "i" for integers, "f" for floats, and "b" for Booleans. Here's an example:

```
// Hungarian notation used to indicate data type
let bFound;      // Boolean
let iCount;      // integer
let sName;       // string
let oPerson;     // object
```

Hungarian notation for JavaScript is advantageous in that it can be used equally well for function arguments. The downside of Hungarian notation is that it makes code somewhat less readable, interrupting the intuitive, sentence-like nature of code that is accomplished without it. For this reason, Hungarian notation has started to fall out of favor among some developers.

The last way to indicate variable type is to use type comments. Type comments are placed right after the variable name but before any initialization. The idea is to place a comment indicating the data type right by the variable, as in this example:

```
// type comments used to indicate type
let found /*:Boolean*/ = false;
let count /*:int*/ = 10;
let name /*:String*/ = "Nicholas";
let person /*:Object*/ = null;
```

Type comments maintain the overall readability of code while injecting type information at the same time. The downside of type comments is that you cannot comment out large blocks of code using multiline comments because the type comments are also multiline comments that will interfere, as this example demonstrates:

```
// The following won't work correctly
/*
let found /*:Boolean*/ = false;
let count /*:int*/ = 10;
let name /*:String*/ = "Nicholas";
let person /*:Object*/ = null;
*/
```

Here, the intent was to comment out all of the variables using a multiline comment. The type comments interfere with this because the first instance of `/*` (second line) is matched with the first instance of `*/` (third line), which will cause a syntax error. If you want to comment out lines of code using type comments, it's best to use single-line comments on each line (many editors will do this for you).

These are the three most common ways to indicate the data type of variables. Each has advantages and disadvantages for you to evaluate before deciding on one. The important thing is to decide which works best for your project and use it consistently.

Loose Coupling

Whenever parts of an application depend too closely on one another, the code becomes too tightly coupled and hard to maintain. The typical problem arises when objects refer directly to one another in such a way that a change to one always requires a change to the other. Tightly coupled software is difficult to maintain and invariably has to be rewritten frequently.

Because of the technologies involved, there are several ways in which web applications can become too tightly coupled. It's important to be aware of this and to try to maintain loosely coupled code whenever possible.

Decouple HTML/JavaScript

One of the most common types of coupling is HTML/JavaScript coupling. On the web, HTML and JavaScript each represent a different layer of the solution: HTML is the data, and JavaScript is the behavior. Because they are intended to interact, there are a number of different ways to tie these two technologies together. Unfortunately, there are some ways that too tightly couple HTML and JavaScript.

JavaScript that appears inline in HTML, either using a `<script>` element with inline code or using HTML attributes to assign event handlers, is too tightly coupled. Consider the following code examples:

```
<!-- tightly coupled HTML/JavaScript using <script> -->
<script>
  document.write("Hello world!");
</script>

<!-- tightly coupled HTML/JavaScript using event handler attribute -->
<input type="button" value="Click Me" onclick="doSomething()" />
```

Although these are both technically correct, in practice they tightly couple the HTML representing the data with the JavaScript that defines the behavior. Ideally, HTML and JavaScript should be completely separate, with the JavaScript being included via external files and attaching behavior using the DOM.

When HTML and JavaScript are too tightly coupled, interpreting a JavaScript error means first determining whether the error occurred in the HTML portion of the solution or in a JavaScript file. It also introduces new types of errors related to the availability of code. In this example, the button may be clicked before the `doSomething()` function is available, causing a JavaScript error. Maintainability is affected because any change to the button's behavior requires touching both the HTML and the JavaScript, when it should require only the latter.

HTML and JavaScript can also be too tightly coupled when the reverse is true: HTML is contained within JavaScript. This usually occurs when using `innerHTML` to insert a chunk of HTML text into the page, as in this example:

```
// tight coupling of HTML to JavaScript
function insertMessage(msg) {
  let container = document.getElementById("container");
  container.innerHTML = `<div class="msg">
    <p> class="post">${msg}</p>
    <p><em>Latest message above.</em></p>
  </div>`;
}
```

Generally speaking, you should avoid creating large amounts of HTML in JavaScript. This, once again, has to do with keeping the layers separate and being able to easily identify the source of errors. When using this example code, a problem with page layout may be related to dynamically created HTML that is improperly formatted. However, locating the error may be difficult because you would typically first view the source of the page to look for the offending HTML but wouldn't find it there because it's dynamically generated. Changes to the data or layout would also require changes to the JavaScript, which indicates that the two layers are too tightly coupled.

HTML rendering should be kept separate from JavaScript as much as possible. When JavaScript is used to insert data, it should do so without inserting markup whenever possible. Markup can typically be included and hidden when the entire page is rendered such that JavaScript can be used to display the markup later, instead of generating it. Another approach is to make an Ajax request to retrieve additional HTML to be displayed; this approach allows the same rendering layer (PHP, JSP, Ruby, and so on) to output the markup, instead of embedding it in JavaScript.

Decoupling HTML and JavaScript can save time during debugging by making it easier to identify the source of errors, and it also eases maintainability: changes to behavior occur only in JavaScript files, whereas changes to markup occur only in rendering files.

Decouple CSS/JavaScript

Another layer of the web tier is CSS, which is primarily responsible for the display of a page. JavaScript and CSS are closely related: they are both layers on top of HTML and as such are often used together. As with HTML and JavaScript, however, it's possible for CSS and JavaScript to be too tightly coupled. The most common example of tight coupling is using JavaScript to change individual styles, as shown here:

```
// tight coupling of CSS to JavaScript
element.style.color = "red";
element.style.backgroundColor = "blue";
```

Because CSS is responsible for the display of a page, any trouble with the display should be addressable by looking just at CSS files. However, when JavaScript is used to change individual styles, such as color, it adds a second location that must be checked and possibly changed. The result is that JavaScript is somewhat responsible for the display of the page and a tight coupling with CSS. If the styles need to change in the future, both the CSS and the JavaScript files may require changes. This creates a maintenance nightmare for developers. A cleaner separation between the layers is needed.

Modern web applications use JavaScript to change styles frequently, so although it's not possible to completely decouple CSS and JavaScript, the coupling can be made looser. This is done by dynamically changing classes instead of individual styles, as in the following example:

```
// loose coupling of CSS to JavaScript
element.className = "edit";
```

By changing only the CSS class of an element, you allow most of the style information to remain strictly in the CSS. JavaScript can be used to change the class, but it's not directly affecting the style of the element. As long as the correct class is applied, then any display issues can be tracked directly to CSS and not to JavaScript.

Once again, the importance of keeping a good separation of layers is paramount. The only source for display issues should be CSS, and the only source for behavior issues should be JavaScript. Keeping a loose coupling between these layers makes your entire application more maintainable.

Decouple Application Logic/Event Handlers

Every web application is typically filled with lots of event handlers listening for numerous different events. Few of them, however, take care to separate application logic from event handlers. Consider the following example:

```
function handleKeyPress(event) {
  if (event.keyCode == 13) {
    let target = event.target;
    let value = 5 * parseInt(target.value);
    if (value > 10) {
      document.getElementById("error-msg").style.display = "block";
    }
  }
}
```

This event handler contains application logic in addition to handling the event. The problem with this approach is twofold. First, there is no way to cause the application logic to occur other than through the event, which makes it difficult to debug. What if the anticipated result didn't occur? Does that mean that the event handler wasn't called or that the application logic failed? Second, if a subsequent event causes the same application logic to occur, you'll need to duplicate the functionality or else extract it into a separate function. Either way, it requires more changes to be made than are really necessary.

A better approach is to separate the application logic from event handlers, so that each handles just what it's supposed to. An event handler should interrogate the `event` object for relevant information and then pass that information to some method that handles the application logic. For example, the previous code can be rewritten like this:

```
function validateValue(value) {
  value = 5 * parseInt(value);
  if (value > 10) {
    document.getElementById("error-msg").style.display = "block";
  }
}

function handleKeyPress(event) {
  if (event.keyCode == 13) {
    let target = event.target;
    validateValue(target.value);
  }
}
```

This updated code properly separates the application logic from the event handler. The `handleKeyPress()` function checks to be sure that the Enter key was pressed (`event.keyCode` is 13) and then gets the target of the event and passes the `value` property into the `validateValue()` function, which contains the application logic. Note that there is nothing in `validateValue()` that depends on any event handler logic whatsoever; it just receives a value and can do everything else based on that value.

Separating application logic from event handlers has several benefits. First, it allows you to easily change the events that trigger certain processes with a minimal amount of effort. If a mouse click initially caused the processing to occur, but now a key press should do the same, it's quite easy to make that change. Second, you can test code without attaching events, making it easier to create unit tests or to automate application flow.

Here are a few rules to keep in mind for loose coupling of application and business logic:

- Don't pass the `event` object into other methods; pass only the data from the `event` object that you need.
- Every action that is possible in the application should be possible without executing an event handler.
- Event handlers should process the event and then hand off processing to application logic.

Keeping this approach in mind is a huge maintainability win in any code base, opening up numerous possibilities for testing and further development.

Programming Practices

Writing maintainable JavaScript isn't just about how the code is formatted; it's also about what the code does. Web applications created in an enterprise environment are often worked on by numerous people at the same time. The goal in these situations is to ensure that the browser environment in which everyone is working has constant and unchanging rules. To achieve this, developers should adhere to certain programming practices.

Respect Object Ownership

The dynamic nature of JavaScript means that almost anything can be modified at any point in time. It's been said that nothing in JavaScript is sacred, as you're unable to mark something as final or constant. This changed somewhat with ECMAScript 5's introduction of tamper-proof objects, but by default, all objects can be modified. In other languages, objects and classes are immutable when you don't have the actual source code. JavaScript allows you to modify any object at any time, making it possible to override default behaviors in unanticipated ways. Because the language doesn't impose limits, it's important and necessary for developers to do so.

Perhaps the most important programming practice in an enterprise environment is to respect object ownership, which means that you don't modify objects that don't belong to you. Put simply: if you're not responsible for the creation or maintenance of an object, its constructor, or its methods, you shouldn't be making changes to it. More specifically:

- Don't add properties to instances or prototypes.
- Don't add methods to instances or prototypes.
- Don't redefine existing methods.

The problem is that developers assume that the browser environment works in a certain way. Changes to objects that are used by multiple people mean that errors will occur. If someone expects a function called `stopEvent()` to cancel the default behavior for an event, and you change it so it does that and also attaches other event handlers, it is certain that problems will follow. Other developers are assuming that the function just does what it did originally, so their usage will be incorrect and possibly harmful because they don't know the side effects.

These rules apply not only to custom types and objects but also to native types and objects such as `Object`, `String`, `document`, `window`, and so on. The potential issues here are even more perilous because browser vendors may change these objects in unannounced and unanticipated ways.

An example of this occurred in the popular Prototype JavaScript library, which implemented the `getElementsByClassName()` method on the `document` object, returning an instance of `Array` that had also been augmented to include a method called `each()`. John Resig outlined on his blog the sequence of events that caused the issue. In his post (<http://ejohn.org/blog/getelementsby-classname-pre-prototype-16/>), he noted that the problem occurred when browsers began to natively implement `getElementsByClassName()`, which returns not an `Array` but rather a `NodeList` that doesn't have an `each()` method. Developers using the Prototype library had gotten used to writing code such as this:

```
document.getElementsByClassName("selected").each(Element.hide);
```

Although this code worked fine in browsers that didn't implement `getElementsByClassName()` natively, it caused an error in the ones that did, as a result of the return value differences. You cannot anticipate how browser vendors will change native objects in the future, so modifying them in any way can lead to issues down the road when your implementation clashes with theirs.

The best approach, therefore, is to never modify objects you don't own. You own an object only when you created it yourself, such as a custom type or object literal. You don't own `Array`, `document`, and so on, because they were there before your code executed. You can still create new functionality for objects by doing the following:

- Create a new object with the functionality you need, and let it interact with the object of interest.
- Create a custom type that inherits from the type you want to modify. You can then modify the custom type with the additional functionality.

Many JavaScript libraries now subscribe to this theory of development, allowing them to grow and adapt even as browsers continually change.

Avoid Globals

Closely related to respecting object ownership is avoiding global variables and functions whenever possible. Once again, this has to do with creating a consistent and maintainable environment in which scripts will be executed. At most, a single global variable should be created on which other objects and functions exist. Consider the following:

```
// two globals - AVOID!!!
var name = "Nicholas";
function sayName() {
  console.log(name);
}
```

This code contains two globals: the variable `name` and the function `sayName()`. These can easily be created on an object that contains both, as in this example:

```
// one global - preferred
var MyApplication = {
  name: "Nicholas",
  sayName: function() {
    console.log(this.name);
  }
};
```

This rewritten version of the code introduces a single global object, `MyApplication`, onto which both `name` and `sayName()` are attached. Doing so clears up a couple of issues that existed in the previous code. First, the variable `name` overwrites the `window.name` property, which possibly interferes with other functionality. Second, it helps to clear up confusion over where the functionality lives. Calling `MyApplication.sayName()` is a logical hint that any issues with the code can be identified by looking at the code in which `MyApplication` is defined.

An extension of the single global approach is the concept of *namespacing*. Namespacing involves creating an object to hold functionality. The Google Closure library utilizes namespaces to organize its contents. Here are some examples:

- `goog.string`—Methods for manipulating strings.
- `goog.html.utils`—Methods for working with HTML.
- `goog.i18n`—Methods for helping with internationalization (i18n).

The single global object `goog` serves as a container onto which other objects are defined. Whenever objects are used simply to group together functionality in this manner, they are called *namespaces*. The entire Google Closure library is built on this concept, allowing it to coexist on the same page with any other JavaScript library.

The important part of namespacing is to decide on a global object name that everyone agrees to use and that is unique enough that others aren't likely to use it as well. In most cases, this can be the name of the company for which you're developing the code, such as `goog` or `Wrox`. You can then start creating namespaces to group your functionality, as in this example:

```
// create global object
var Wrox = {};

// create namespace for Professional JavaScript
Wrox.ProJS = {};

// attach other objects used in the book
Wrox.ProJS.EventUtil = { ... };
Wrox.ProJS.CookieUtil = { ... };
```

In this example, `Wrox` is the global on which namespaces are created. If all code for this book is placed under the `Wrox.ProJS` namespace, it leaves other authors to add their code onto the `Wrox` object as well. As long as everyone follows this pattern, there's no reason to be worried that someone else will also write an object called `EventUtil` or `CookieUtil` because it will exist on a different namespace. Consider this example:

```
// create namespace for Professional Ajax
Wrox.ProAjax = {};

// attach other objects
Wrox.ProAjax.EventUtil = { ... };
Wrox.ProAjax.CookieUtil = { ... };

// you can still access the ProJS one
Wrox.ProJS.EventUtil.addHandler( ... );

// and the ProAjax one separately
Wrox.ProAjax.EventUtil.addHandler( ... );
```

Although namespacing requires a little more code, it is worth the trade-off for maintainability purposes. Namespacing helps ensure that your code can work on a page with other code in a nonharmful way.

Avoid Null Comparisons

Because JavaScript doesn't do any automatic type checking, it becomes the developer's responsibility. As a result, very little type checking actually gets done in JavaScript code. The most common

type check is to see if a value is `null`. Unfortunately, checking a value against `null` is overused and frequently leads to errors due to insufficient type checking. Consider the following:

```
function sortArray(values) {  
  if (values != null) {      // AVOID!!  
    values.sort(comparator);  
  }  
}
```

The purpose of this function is to sort an array with a given comparator. The `values` argument must be an array for the function to execute correctly, but the `if` statement simply checks to see that `values` isn't `null`. There are several values that can make it past the `if` statement, including any string or any number, which would then cause the function to throw an error.

Realistically, `null` comparisons are rarely good enough to be used. Values should be checked for what they are expected to be, not for what they aren't expected to be. For example, in the previous code, the `values` argument is expected to be an array, so you should be checking to see if it is an array, rather than checking to see if it's not `null`. The function can be rewritten more appropriately as follows:

```
function sortArray(values) {  
  if (values instanceof Array) { // preferred  
    values.sort(comparator);  
  }  
}
```

This version of the function protects against all invalid values and doesn't need to use `null` at all.

If you see a `null` comparison in code, try replacing it using one of the following techniques:

- If the value should be a reference type, use the `instanceof` operator to check its constructor.
- If the value should be a primitive type, use the `typeof` operator to check its type.
- If you're expecting an object with a specific method name, use the `typeof` operator to ensure that a method with the given name exists on the object.

The fewer `null` comparisons in code, the easier it is to determine the purpose of the code and to eliminate unnecessary errors.

Use Constants

The goal of relying on constants is to isolate data from application logic in such a way that it can be changed without risking the introduction of errors. Strings that are displayed in the user interface should always be extracted in such a way as to allow for internationalization. URLs should also be extracted because they have a tendency to change as an application grows. Basically, each of these has a possibility of changing for one reason or another, and a change would mean going into the function and changing code there. Any time you're changing application logic code, you open up the possibility of creating errors. You can insulate application logic from data changes by extracting data into constants that are defined separately.

The key is to separate data from the logic that uses it. The types of values to look for are as follows:

- **Repeated values**—Any values that are used in more than one place should be extracted into a constant. This limits the chance of errors when one value is changed but others are not. This includes CSS class names.
- **User interface strings**—Any strings that are to be displayed to the user should be extracted for easier internationalization.
- **URLs**—Resource locations tend to change frequently in web applications, so having a common place to store all URLs is recommended.
- **Any value that may change**—Any time you're using a literal value in code, ask yourself if this value might change in the future. If the answer is yes, then the value should be extracted into a constant.

Using constants is an important technique for enterprise JavaScript development because it makes code more maintainable and keeps it safe from data changes.

PERFORMANCE

The amount of JavaScript that developers now write per web page has grown dramatically since the language was first introduced. With that increase came concerns over the runtime execution of JavaScript code. JavaScript was originally an interpreted language, so the speed of execution was significantly slower than it was for compiled languages. Chrome was the first browser to introduce an optimizing engine that compiles JavaScript into native code. Since then, all other major browsers have followed suit and have implemented JavaScript compilation.

Even with the move to compiled JavaScript, it's still possible to write slow code. However, there are some basic patterns that, when followed, ensure the fastest possible execution of code.

Be Scope-Aware

The “Variables, Scope, and Memory” chapter discussed the concept of scopes in JavaScript and how the scope chain works. As the number of scopes in the scope chain increases, so does the amount of time it takes to access variables outside of the current scope. It is always slower to access a global variable than it is to access a local variable, because the scope chain must be traversed. Anything you can do to decrease the amount of time spent traversing the scope chain will increase overall script performance.

Avoid Global Lookups

Perhaps the most important thing you can do to improve the performance of your scripts is to be wary of global lookups. Global variables and functions are always more expensive to use than local ones because they involve a scope chain lookup. Consider the following function:

```
function updateUI() {
  let imgs = document.getElementsByTagName("img");
  for (let i = 0, len = imgs.length; i < len; i++) {
    imgs[i].title = `${document.title} image ${i}`;
  }
}
```

```

    let msg = document.getElementById("msg");
    msg.innerHTML = "Update complete.";
  }

```

This function may look perfectly fine, but it has three references to the global `document` object. If there are multiple images on the page, the `document` reference in the `for` loop could get executed dozens or hundreds of times, each time requiring a scope chain lookup. By creating a local variable that points to the `document` object, you can increase the performance of this function by limiting the number of global lookups to just one:

```

function updateUI() {
  let doc = document;
  let imgs = doc.getElementsByTagName("img");
  for (let i = 0, len = imgs.length; i < len; i++) {
    imgs[i].title = `${doc.title} image ${i}`;
  }

  let msg = doc.getElementById("msg");
  msg.innerHTML = "Update complete.";
}

```

Here, the `document` object is first stored in the local `doc` variable. The `doc` variable is then used in place of `document` throughout the rest of the code. There's only one global lookup in this function, compared to the previous version, ensuring that it will run faster.

A good rule of thumb is to store any global object that is used more than once in a function as a local variable.

Avoid the `with` Statement

The `with` statement should be avoided where performance is important. Similar to functions, the `with` statement creates its own scope and therefore increases the length of the scope chain for code executed within it. Code executed within a `with` statement is guaranteed to run slower than code executing outside because of the extra steps in the scope chain lookup.

It is rare that the `with` statement is required because it is mostly used to eliminate extra characters. In most cases, a local variable can be used to accomplish the same thing without introducing a new scope. Here is an example:

```

function updateBody() {
  with(document.body) {
    console.log(tagName);
    innerHTML = "Hello world!";
  }
}

```

The `with` statement in this code enables you to use `document.body` more easily. The same effect can be achieved by using a local variable, as follows:

```

function updateBody() {
  let body = document.body;
  console.log(body.tagName);
  body.innerHTML = "Hello world!";
}

```

Although this code is slightly longer, it reads better than the `with` statement, ensuring that you know the object to which `tagName` and `innerHTML` belong. This code also saves global lookups by storing `document.body` in a local variable.

Choose the Right Approach

As with other languages, part of the performance equation has to do with the algorithm or approach used to solve the problem. Skilled developers know from experience which approaches are likely to achieve better performance results. Many of the techniques and approaches that are typically used in other programming languages can also be used in JavaScript.

Avoid Unnecessary Property Lookup

In computer science, the complexity of algorithms is represented using O notation. The simplest, and fastest, algorithm is a constant value or $O(1)$. After that, the algorithms just get more complex and take longer to execute. The following table lists the common types of algorithms found in JavaScript.

NOTATION	NAME	DESCRIPTION
$O(1)$	Constant	Amount of time to execute remains constant no matter the number of values. Represents simple values and values stored in variables.
$O(\log n)$	Logarithmic	Amount of time to execute is related to the number of values, but each value need not be retrieved for the algorithm to complete. Example: binary search.
$O(n)$	Linear	Amount of time to execute is directly related to the number of values. Example: iterating over all items in an array.
$O(n^2)$	Quadratic	Amount of time to execute is related to the number of values such that each value must be retrieved at least n times. Example: insertion sort.

Constant values, or $O(1)$, refer to both literals and values that are stored in variables. The notation $O(1)$ indicates that the amount of time necessary to retrieve a constant value remains the same regardless of the number of values. Retrieving a constant value is an extremely efficient process and so is quite fast. Consider the following:

```
let value = 5;
let sum = 10 + value;
console.log(sum);
```

This code performs four constant value lookups: the number 5, the variable `value`, the number 10, and the variable `sum`. The overall complexity of this code is then considered to be $O(1)$.

Accessing array items is also an $O(1)$ operation in JavaScript, performing just as well as a simple variable lookup. So the following code is just as efficient as the previous example:

```
let values = [5, 10];
let sum = values[0] + values[1];
console.log(sum);
```

Using variables and arrays is more efficient than accessing properties on objects, which is an $O(n)$ operation. Every property lookup on an object takes longer than accessing a variable or array, because a search must be done for a property of that name up the prototype chain. Put simply, the more property lookups there are, the slower the execution time. Consider the following:

```
let values = { first: 5, second: 10 };
let sum = values.first + values.second;
console.log(sum);
```

This code uses two property lookups to calculate the value of `sum`. Doing one or two property lookups may not result in significant performance issues, but doing hundreds or thousands will definitely slow down execution.

Be wary of multiple property lookups to retrieve a single value. For example, consider the following:

```
let query = window.location.href.substring(window.location.href.indexOf("?"));
```

In this code, there are six property lookups: three for `window.location.href.substring()` and three for `window.location.href.indexOf()`. You can easily identify property lookups by counting the number of dots in the code. This code is especially inefficient because the `window.location.href` value is being used twice, so the same lookup is done twice.

Whenever an object property is being used more than once, store it in a local variable. You'll still take the initial $O(n)$ hit to access the value the first time, but every subsequent access will be $O(1)$, which more than makes up for it. For example, the previous code can be rewritten as follows:

```
let url = window.location.href;
let query = url.substring(url.indexOf("?"));
```

This version of the code has only four property lookups, a savings of 33 percent over the original. Making this kind of optimization in a large script is likely to lead to larger gains.

Generally speaking, any time you can decrease the complexity of an algorithm, you should replace as many property lookups as possible by using local variables to store the values. Furthermore, if you have an option to access something as a numeric array position or a named property (such as with `NodeList` objects), use the numeric position.

Optimize Loops

Loops are one of the most common constructs in programming and, as such, are found frequently in JavaScript. Optimizing these loops is an important part of the performance optimization process because they run the same code repeatedly, automatically increasing execution time. There's been a great deal of research done into loop optimization for other languages, and these techniques also apply to JavaScript. The basic optimization steps for a loop are as follows:

1. **Simplify the terminal condition**—Because the terminal condition is evaluated each time through the loop, it should be as fast as possible. This means avoiding property lookups or other $O(n)$ operations.
2. **Simplify the loop body**—The body of the loop is executed the most, so make sure it's as optimized as possible. Make sure there's no intensive computation being performed that could easily be moved to outside the loop.
3. **Use posttest loops**—The most commonly used loops are `for` and `while`, both of which are pretest loops. Posttest loops, such as `do-while`, avoid the initial evaluation of the terminal condition and tend to run faster.

NOTE *In older browsers, it was more efficient to start loop iterators at their maximum value and decrement them down to 0. This was faster due to the reduced number of instructions that the JavaScript engine would use to check the loop branch condition. In modern browsers, there will be no perceptible performance difference, so you should use an iterator format that is most sensible for the purposes of your code.*

These changes are best illustrated with an example. The following is a basic for loop:

```
for (let i = 0; i < values.length; i++) {
  process(values[i]);
}
```

This code increments the variable `i` from 0 up to the total number of items in the `values` array. Assuming that the order in which the values are processed is irrelevant, the loop can be changed to decrement `i` instead, as follows:

```
for (let i = values.length - 1; i >= 0; i--) {
  process(values[i]);
}
```

Here, the variable `i` is decremented each time through the loop. In the process, the terminal condition is simplified by removing the $O(n)$ call to `values.length` and replacing it with the $O(1)$ call of 0. Because the loop body has only a single statement, it can't be optimized further. However, the loop itself can be changed into a posttest loop like this:

```
let i = values.length-1;
if (i > -1) {
  do {
    process(values[i]);
  }while(--i >= 0);
}
```

The primary optimization here is combining the terminal condition and the decrement operator into a single statement. At this point, any further optimization would have to be done to the `process()` function itself because the loop is fully optimized.

Keep in mind that using a posttest loop works only when you're certain that there will always be at least one value to process. An empty array causes an unnecessary trip through the loop that a pre-test loop would otherwise avoid.

Unrolling Loops

When the number of times through a loop is finite, it is often faster to eliminate the loop altogether and replace it with multiple function calls. Consider the loop from the previous example. If the length of the array will always be the same, it may be more optimal to simply call `process()` on each item, as in the following code:

```
// eliminated the loop
process(values[0]);
process(values[1]);
process(values[2]);
```

This example assumes that there are only three items in the `values` array and simply calls `process()` directly on each item. Unrolling loops in this way eliminates the overhead of setting up a loop and processing a terminal condition, making the code run faster.

If the number of iterations through the loop can't be determined ahead of time, you may want to consider using a technique called *Duff's device*. The technique is named after its creator, Tom Duff, who first proposed using it in the C programming language. Jeff Greenberg is credited with implementing Duff's device in JavaScript. The basic idea of Duff's device is to unroll a loop into a series of statements by calculating the number of iterations as a multiple of 8. Consider the following code example:

```
// credit: Jeff Greenberg for JS implementation of Duff's Device
// assumes values.length > 0
let iterations = Math.ceil(values.length / 8);
let startAt = values.length % 8;
let i = 0;

do {
  switch(startAt) {
    case 0: process(values[i++]);
    case 7: process(values[i++]);
    case 6: process(values[i++]);
    case 5: process(values[i++]);
    case 4: process(values[i++]);
    case 3: process(values[i++]);
    case 2: process(values[i++]);
    case 1: process(values[i++]);
  }
  startAt = 0;
} while (--iterations > 0);
```

This implementation of Duff's device starts by calculating how many iterations through the loop need to take place by dividing the total number of items in the `values` array by 8. The ceiling function is then used to ensure that the result is a whole number. The `startAt` variable holds the number of items that wouldn't be processed if the iterations were based solely on dividing by 8. When the loop executes for the first time, the `startAt` variable is checked to see how many extra calls should be made. For instance, if there are 10 values in the array, `startAt` would be equal to 2, so `process()` would be called only twice the first time through the loop. At the bottom of the loop, `startAt` is reset to 0 so that each subsequent time through the loop results in eight calls to `process()`. This unrolling speeds up processing of large data sets.

The book *Speed Up Your Site* by Andrew B. King (New Riders, 2003) proposed an even faster Duff's device technique that separated the `do-while` loop into two separate loops. Here's an example:

```
// credit: Speed Up Your Site (New Riders, 2003)
let iterations = Math.floor(values.length / 8);
let leftover = values.length % 8;
let i = 0;

if (leftover > 0) {
  do {
    process(values[i++]);
  } while (--leftover > 0);
}
```

```

do {
  process(values[i++]);
  process(values[i++]);
  process(values[i++]);
  process(values[i++]);
  process(values[i++]);
  process(values[i++]);
  process(values[i++]);
  process(values[i++]);
} while (--iterations > 0);

```

In this implementation, the leftover count that wouldn't have been handled in the loop when simply dividing by 8 is handled in an initial loop. Once those extra items are processed, execution continues in the main loop that calls `process()` eight times. This approach is almost 40 percent faster than the original Duff's device implementation.

Unrolling loops can yield big savings for large data sets but may not be worth the extra effort for small data sets. The trade-off is that it takes more code to accomplish the same task, which is typically not worth it when large data sets aren't being processed.

Avoid Double Interpretation

Double interpretation penalties exist when JavaScript code tries to interpret JavaScript code. This situation arises when using the `eval()` function or the `Function` constructor or when using `setTimeout()` with a string argument. Here are some examples:

```

// evaluate some code - AVOID!!
eval("console.log('Hello world!')");

// create a new function - AVOID!!
let sayHi = new Function("console.log('Hello world!')");

// set a timeout - AVOID!!
setTimeout("console.log('Hello world!')", 500);

```

In each of these instances, a string containing JavaScript code has to be interpreted. This can't be done during the initial parsing phase because the code is contained in a string, which means a new parser has to be started while the JavaScript code is running to parse the new code. Instantiating a new parser has considerable overhead, so the code runs slower than if it were included natively.

There are workarounds for all of these instances. It's rare that `eval()` is absolutely necessary, so try to avoid it whenever possible. In this case, the code could just be included inline. For the `Function` constructor, the code can be rewritten as a regular function quite easily, and the `setTimeout()` call can pass in a function as the first argument. Here are some examples:

```

// fixed
console.log('Hello world!');

// create a new function - fixed
let sayHi = function() {
  console.log('Hello world!');
};

// set a timeout - fixed
setTimeout(function() {

```



```
    console.log('Hello world!');  
  }, 500);
```

To increase the performance of your code, avoid using strings that need to be interpreted as JavaScript whenever possible.

Other Performance Considerations

There are a few other things to consider when evaluating the performance of your script. The following aren't major issues, but they can make a difference when used frequently:

- **Native methods are fast**—Whenever possible, use a native method instead of one written in JavaScript. Native methods are written in compiled languages such as C or C++ and thus run much faster than those in JavaScript. The most often forgotten methods in JavaScript are the complex mathematical operations available on the `Math` object; these methods always run faster than any JavaScript equivalent for calculating sine, cosine, and so on.
- **Switch statements are fast**—If you have a complex series of `if-else` statements, converting it to a single `switch` statement can result in faster code. You can further improve the performance of `switch` statements by organizing the cases in the order of most likely to least likely.
- **Bitwise operators are fast**—When performing mathematical operations, bitwise operations are always faster than any Boolean or numeric arithmetic. Selectively replacing arithmetic operations with bitwise operations can greatly improve the performance of complex calculations. Operations such as modulus, logical AND, and logical OR are good candidates to be replaced with bitwise operations.

Minimize Statement Count

The number of statements in JavaScript code affects the speed with which the operations are performed. A single statement can complete multiple operations faster than multiple statements each performing a single operation. The task, then, is to seek out statements that can be combined in order to decrease the execution time of the overall script. To do so, you can look for several patterns.

Multiple Variable Declarations

One area in which developers tend to create too many statements is in the declaration of multiple variables. It's quite common to see code declaring multiple variables using multiple `let` statements, such as the following:

```
// four statements - wasteful  
let count = 5;  
let color = "blue";  
let values = [1,2,3];  
let now = new Date();
```

In strongly typed languages, variables of different data types must be declared in separate statements. In JavaScript, however, all variables can be declared using a single `let` statement. The preceding code can be rewritten as follows:

```
// one statement  
let count = 5,  
    color = "blue",
```

```
values = [1,2,3],  
now = new Date();
```

Here, the variable declarations use a single `let` statement and are separated by commas. This is an optimization that is easy to make in most cases and performs much faster than declaring each variable separately.

Insert Iterative Values

Any time you are using an iterative value (that is, a value that is being incremented or decremented at various locations), combine statements whenever possible. Consider the following code snippet:

```
let name = values[i];  
i++;
```

Each of the two preceding statements has a single purpose: the first retrieves a value from `values` and stores it in `name`; the second increments the variable `i`. These can be combined into a single statement by inserting the iterative value into the first statement, as shown here:

```
let name = values[i++];
```

This single statement accomplishes the same thing as the previous two statements. Because the increment operator is postfix, the value of `i` isn't incremented until after the rest of the statement executes. Whenever you have a similar situation, try to insert the iterative value into the last statement that uses it.

Use Array and Object Literals

Throughout this book, you've seen two ways of creating arrays and objects: using a constructor or using a literal. Using constructors always leads to more statements than are necessary to insert items or define properties, whereas literals complete all operations in a single statement. Consider the following example:

```
// four statements to create and initialize array - wasteful  
let values = new Array();  
values[0] = 123;  
values[1] = 456;  
values[2] = 789;  
  
// four statements to create and initialize object - wasteful  
let person = new Object();  
person.name = "Nicholas";  
person.age = 29;  
person.sayName = function() {  
    console.log(this.name);  
};
```

In this code, an array and an object are created and initialized. Each requires four statements: one to call the constructor and three to assign data. These can easily be converted to use literals as follows:

```
// one statement to create and initialize array  
let values = [123, 456, 789];  
  
// one statement to create and initialize object  
let person = {  
    name: "Nicholas",  
    age: 29,
```

```
sayName() {  
    console.log(this.name);  
}  
};
```

This rewritten code contains only two statements: one to create and initialize the array, and one to create and initialize the object. What previously took eight statements now takes only two, reducing the statement count by 75 percent. The value of these optimizations is even greater in codebases that contain thousands of lines of JavaScript.

Whenever possible, replace your array and object declarations with their literal representation to eliminate unnecessary statements.

NOTE *Reducing statement count in your codebase is a good goal, but not an absolute law. It is possible to condense too much logic into a single statement for it to be easily comprehensible.*

Optimize DOM Interactions

Of all the parts of JavaScript, the DOM is without a doubt the slowest part. DOM manipulations and interactions take a large amount of time because they often require rerendering all or part of the page. Furthermore, seemingly trivial operations can take longer to execute because the DOM manages so much information. Understanding how to optimize interactions with the DOM can greatly increase the speed with which scripts complete.

Minimize Live Updates

Whenever you access part of the DOM that is part of the displayed page, you are performing a *live update*. Live updates are so called because they involve immediate (live) updates of the page's display to the user. Every change, whether it be inserting a single character or removing an entire section, incurs a performance penalty as the browser recalculates thousands of measurements to perform the update. The more live updates you perform, the longer it will take for the code to completely execute. The fewer live updates necessary to complete an operation, the faster the code will be. Consider the following example:

```
let list = document.getElementById("myList"),  
    item;  
  
for (let i = 0; i < 10; i++) {  
    item = document.createElement("li");  
    list.appendChild(item);  
    item.appendChild(document.createTextNode('Item ${i}'));  
}
```

This code adds ten items to a list. For each item that is added, there are two live updates: one to add the `` element and another to add the text node to it. Because ten items are being added, that's a total of twenty live updates to complete this operation.

To fix this performance bottleneck, you need to reduce the number of live updates. There are generally two approaches to this. The first is to remove the list from the page, perform the updates, and then reinsert the list into the same position. This approach is not ideal because it can cause unnecessary flickering as the page updates each time. The second approach is to use a document fragment to build up the DOM structure and then add it to the `list` element. This approach avoids live updates and page flickering. Consider the following:

```
let list = document.getElementById("myList"),
    fragment = document.createDocumentFragment(),
    item;

for (let i = 0; i < 10; i++) {
  item = document.createElement("li");
  fragment.appendChild(item);
  item.appendChild(document.createTextNode("Item " + i));
}

list.appendChild(fragment);
```

There is only one live update in this example, and it occurs after all items have been created. The document fragment is used as a temporary placeholder for the newly created items. All items are then added to the list, using `appendChild()`. Remember, when a document fragment is passed in to `appendChild()`, all of the children of the fragment are appended to the parent, but the fragment itself is never added.

Whenever updates to the DOM are necessary, consider using a document fragment to build up the DOM structure before adding it to the live document.

Use innerHTML

There are two ways to create new DOM nodes on the page: using DOM methods such as `createElement()` and `appendChild()`, and using `innerHTML`. For small DOM changes, the two techniques perform roughly the same. For large DOM changes, however, using `innerHTML` is much faster than creating the same DOM structure using standard DOM methods.

When `innerHTML` is set to a value, an HTML parser is created behind the scenes, and the DOM structure is created using the native DOM calls rather than JavaScript-based DOM calls. The native methods execute much faster because they are compiled rather than interpreted. The previous example can be rewritten to use `innerHTML` like this:

```
let list = document.getElementById("myList"),
    html = "";

for (let i = 0; i < 10; i++) {
  html += '<li>Item ${i}</li>';
}

list.innerHTML = html;
```

This code constructs an HTML string and then assigns it to `list.innerHTML`, which creates the appropriate DOM structure. Although there is always a small performance hit for string concatenation, this technique still performs faster than performing multiple DOM manipulations.

The key to using `innerHTML`, as with other DOM operations, is to minimize the number of times it is called. For instance, the following code uses `innerHTML` too much for this operation:

```
let list = document.getElementById("myList");

for (let i = 0; i < 10; i++) {
  list.innerHTML += '<li>Item ${i}</li>'; // AVOID!!!
}
```

The problem with this code is that `innerHTML` is called each time through the loop, which is incredibly inefficient. A call to `innerHTML` is, in fact, a live update and should be treated as such. It's far faster to build up a string and call `innerHTML` once than it is to call `innerHTML` multiple times.

NOTE `innerHTML` may offer superior performance, but it exposes an enormous XSS attack surface. Any time it is used to interpolate data that you do not explicitly control, an attacker can inject executable code. Use with caution.

Use Event Delegation

Most web applications make extensive use of event handlers for user interaction. There is a direct relationship between the number of event handlers on a page and the speed with which the page responds to user interaction. To mitigate these penalties, you should use event delegation whenever possible.

Event delegation takes advantage of events that bubble. Any event that bubbles can be handled not just at the event target but also at any of the target's ancestors. Using this knowledge, you can attach event handlers at a high level that are responsible for handling events for multiple targets. Whenever possible, attach an event handler at the document level that can handle events for the entire page.

Beware of HTMLCollections

The pitfalls of `HTMLCollection` objects have been discussed throughout this book because they are a big performance sink for web applications. Keep in mind that any time you access an `HTMLCollection`, whether it be a property or a method, you are performing a query on the document, and that querying is quite expensive. Minimizing the number of times you access an `HTMLCollection` can greatly improve the performance of a script.

Perhaps the most important area in which to optimize `HTMLCollection` access is loops. Moving the length calculation into the initialization portion of a `for` loop was discussed previously. Now consider this example:

```
let images = document.getElementsByTagName("img");

for (let i = 0, len = images.length; i < len; i++) {
  // process
}
```

The key here is that the `length` is stored in the `len` variable instead of constantly accessing the `length` property of the `HTMLCollection`. When using an `HTMLCollection` in a loop, you should

make your next step a retrieval of a reference to the item you'll be using, as shown here, in order to avoid calling the `HTMLCollection` multiple times in the loop body:

```
let images = document.getElementsByTagName("img"),
    image;

for (let i = 0, len=images.length; i < len; i++) {
    image = images[i];
    // process
}
```

This code adds the `image` variable, which stores the current image. Once this is complete, there should be no further reason to access the `images` `HTMLCollection` inside the loop.

When writing JavaScript, it's important to realize when `HTMLCollection` objects are being returned so you can minimize accessing them. An `HTMLCollection` object is returned when any of the following occurs:

- A call to `getElementsByTagName()` is made.
- The `childNodes` property of an element is retrieved.
- The `attributes` property of an element is retrieved.
- A special collection is accessed, such as `document.forms`, `document.images`, and so forth.

Understanding when you're using `HTMLCollection` objects and making sure you're using them appropriately can greatly speed up code execution.

DEPLOYMENT

Perhaps the most important part of any JavaScript solution is the final deployment to the website or web application in production. You've done a lot of work before this point, architecting and optimizing a solution for general consumption. It's time to move out of the development environment and into the web, where real users can interact with it. Before you do so, however, there are a number of issues that need to be addressed.

Build Process

One of the most important things you can do to ready JavaScript code for deployment is to develop some type of build process around it. The typical pattern for developing software is write-compile-test, in that you write the code, compile it, and then run it to ensure that it works. Because JavaScript is not a compiled language, the pattern often becomes write-test, where the code you write is the same code you test in the browser. The problem with this approach is that it's not optimal; the code you write should not be passed, untouched, to the browser, for the following reasons:

- **Intellectual property issues**—If you put the fully commented source code online, it's easier for others to figure out what you're doing, reuse it, and potentially figure out security holes.
- **File size**—You write code in a way that makes it easy to read, which is good for maintainability but bad for performance. The browser doesn't benefit from the extra white space, indentation, or verbose function and variable names.

- ▶ **Code organization**—The way you organize code for maintainability isn't necessarily the best way to deliver it to the browser.

For these reasons, it's best to define a build process for your JavaScript files.

File Structure

A build process starts by defining a logical structure for storing your files in source control. It's best to avoid having a single file that contains all of your JavaScript. Instead, follow the pattern that is typically taken in object-oriented languages: separate each object or custom type into its own file. Doing so ensures that each file contains just the minimum amount of code, making it easier to make changes without introducing errors. Additionally, in environments that use concurrent source control systems such as Git, CVS, or Subversion, this reduces the risk of conflicts during merge operations.

Keep in mind that separating your code into multiple files is for maintainability and not for deployment. For deployment, you'll want to combine the source files into one or more rollup files. It's recommended that web applications use the smallest number of JavaScript files possible, because HTTP requests are some of the main performance bottlenecks on the web. Keep in mind that including a JavaScript file via a vanilla `<script>` tag is a blocking operation that stops all other downloads while the code is downloaded and executed. Therefore, try to logically group JavaScript code into deployment files.

Task Runners

If you're putting together an application that's anything more than a few files, you will likely find yourself reaching for a task runner to automate tasks for you. The task runner can perform jobs such as linting, bundling, transpilation, starting a local server, deployment, or any other scripted program.

Much of the time, jobs that your task runner will perform are available through command-line interfaces, and therefore your task runner will merely be a tool that aids in grouping and ordering complex command line invocations. In this sense, a task runner in many ways is very similar to a `.bashrc` file. In other cases, the tools you wish to use in automated tasks will have designated plugins compatible

If you're using NodeJS and npm to package your JavaScript assets, two popular task runners are Grunt (www.gruntjs.com) and Gulp (www.gulpjs.com). Both of these tools are robust task runners whose jobs and instructions are defined inside configuration files written in plain JavaScript. The benefit of using these task runners is that each enjoys an ecosystem of plugins, which allow the tools to directly interface with npm packages. Details of these plugins can be found in the appendixes.

Tree Shaking

An increasingly common and extremely effective strategy for reducing payload size is tree shaking. As mentioned in the *Modules* chapter, using a static module declaration style means that build tools can determine which parts of the codebase depend on other parts. More importantly, tree shaking is also capable of determining which parts of the codebase are not needed at all.

Build tools that implement tree shaking acknowledge that module imports are frequently selective and that entire segments of module files can be ignored in the final bundled file. Suppose this is your example application:

```
import { foo } from './utils.js';

console.log(foo);
export const foo = 'foo';
export const bar = 'bar'; // unused
```

Here, the `bar` export is never used, and static analysis by a build tool can easily determine this is the case. When performing tree shaking, the build tool will completely strip out the `bar` export from the bundled file. Static analysis also means that the build tool can determine dependencies that are unused and decline to include those as well. By performing tree shaking, the file size savings of the eventual bundle can be enormous.

Module Bundlers

Just because your codebase is written in modules doesn't mean that it should necessarily be served as modules. Often, JavaScript codebases composed of a large collection of modules will be bundled together at build time and served as one or a few different JavaScript files.

The module bundler's job is to identify the landscape of JavaScript dependencies involved in an application, combine them into a monolithic application, make informed decisions about how the modules should be serially organized and concatenated, and generate the output files that will be provided to the browser.

There is an abundance of build tooling that allows you to accomplish such a feat. Webpack, Rollup, and Browserify are just a few of the many options you have to convert a module-based codebase into a universally compatible page script.

Validation

Even though IDEs that understand and support JavaScript are starting to appear, most developers still check their syntax by running code in a browser. There are a couple of problems with this approach. First, this validation can't be easily automated or ported from system to system. Second, aside from syntax errors, problems are encountered only when code is executed, leaving it possible for errors to occur. Several tools are available to help identify potential issues with JavaScript code, the most popular being *Douglas Crockford's JSLint* (www.jshint.com) and ESLint (www.eslint.org).

Linters look for syntax errors and common coding errors in JavaScript code. Some of the potential issues they surface are as follows:

- Use of `eval()`
- Use of undeclared variables
- Omission of semicolons
- Improper line breaks
- Incorrect comma usage

- Omission of braces around statements
- Omission of `break` in switch cases
- Variables being declared twice
- Use of `with`
- Incorrect use of equals (instead of double- or triple-equals)
- Unreachable code

Adding code validation to your development cycle helps to avoid errors down the road. It's recommended that developers add some type of code validation to the build process as a way of identifying potential issues before they become errors.

NOTE *A list of JavaScript code validators can be found in Appendix D.*

Compression

When talking about JavaScript file compression, you're really talking about two things: *code size* and *wire weight*. Code size refers to the number of bytes that need to be parsed by the browser, and wire weight refers to the number of bytes that are actually transmitted from the server to the browser. In the early days of web development, these two numbers were almost always identical because source files were transmitted, unchanged, from server to client. In today's web, however, the two are rarely equal and realistically should never be.

Code Minification

Because JavaScript isn't compiled into byte code and is transmitted as source code, the source code files usually contain additional information and formatting that have no effect on the browser's JavaScript interpreter. A JavaScript minifier will perform transformations on your source code to make the file size as small as possible while retaining identical program flow.

Comments, extra white space, and long variable or function names improve readability for developers but are unnecessary extra bytes when sent to the browser. A minifier can decrease the file size by performing the following duties:

- Remove extra white space (including line breaks)
- Remove all comments
- Shorten variable names, function names, and other identifiers

All JavaScript files should be minified with a minification tool before being deployed to a production environment. Adding a step in your build process to compress JavaScript files is an easy way to ensure that this always happens.

NOTE *In the context of web development, the term “minification” is often used interchangeably with “compression.” Doing so can be considered a minor faux pas, as the semantics of each have little overlap.*

Minification is a process where the minified file size is smaller than the original, but the minified file is still syntactically correct code. Generally, minification is only useful for interpreted languages like JavaScript because languages that are formally compiled into a binary will be minified by the compiler as a matter of course.

Compression is distinct from minification in that a compressed file is also smaller than the original but is not syntactically correct code. A compressed file must be uncompressed in order to regain the form of readable code. Compression will result in a smaller file size than minification, as compression algorithms do not have to preserve the syntactical structure of the file and therefore can take additional liberties.

JavaScript Compilation

Similar in spirit to minification, code compilation generally refers to the process of taking source code and converting it into a form that is behaviorally identical but uses fewer bytes of JavaScript. This is distinct from minification in that the post-compilation code structure may be different, but it will still exhibit the same behavior as your original source code. Compilers are able to do this by ingesting the entirety of your JavaScript code and performing robust analysis on program flow.

Compilation might perform some of the following operations:

- Remove unused code
- Transform parts of code to use more concise syntax
- Global inlining of function calls, constants, and variables

JavaScript Transpilation

The code in your project repository will almost never be the exact code that will execute in your browser. ES6, ES7, and ES8 all introduce wonderful abilities into the ECMAScript specification, but different browsers will fully implement each of their features at different paces.

Using transpilation will allow you to wield all the newest syntactical specification features without having to worry about backwards browser compatibility. You can transpile your modern code to an older ECMAScript version—typically ES3 or ES5, depending on your needs—so that your code can work everywhere. Transpilation tools are covered in the appendixes.

NOTE *The terms “transpilation” and “compilation” are often used interchangeably. Compilation is the process of converting source code written in one language into a different language. Transpilation is essentially the same process as compilation, but the end language will have a similar level of abstraction as the original language. Therefore, converting ES6/7/8 code into ES3/5 is technically both compilation and transpilation, although transpilation is a more exact term to describe the process.*

HTTP Compression

Wire weight refers to the actual number of bytes sent from the server to the browser. The number of bytes doesn't necessarily have to be the same as the code size, because of the compression capabilities of both the server and the browser. All of the five major web browsers—Internet Explorer/Edge, Firefox, Safari, Chrome, and Opera—support client-side decompression of resources that they receive. The server is therefore able to compress JavaScript files using server-dependent capabilities. As part of the server response, a header is included indicating that the file has been compressed using a given format. The browser then looks at the header to determine that the file is compressed, and then decompresses it using the appropriate format. The result is that the amount of bytes transferred over the network is significantly less than the original code size.

For example, using two modules available for the Apache web server (`mod_gzip` and `mod_deflate`) results in savings of around 70 percent of the original file size of JavaScript files. This is largely due to the fact that JavaScript files are plain text and can therefore be compressed very efficiently. Decreasing the wire weight of your files decreases the amount of time it takes to transmit to the browser. Keep in mind that there is a slight trade-off because the server must spend time compressing the files on each request, and the browser must take some time to decompress the files once they arrive. Generally speaking, however, the trade-off is well worth it.

NOTE *Most web servers, both open source and commercial, have some HTTP compression capabilities. Please consult the documentation for your server to determine how to configure compression properly.*

SUMMARY

As JavaScript development has matured, best practices have emerged. What once was considered a hobby is now a legitimate profession and, as such, has experienced the type of research into maintainability, performance, and deployment traditionally done for other programming languages.

Maintainability in JavaScript has to do partially with the following code conventions:

- Code conventions from other languages may be used to determine when to comment and how to indent, but JavaScript requires some special conventions to make up for the loosely typed nature of the language.
- Because JavaScript must coexist with HTML and CSS, it's also important to let each wholly define its purpose: JavaScript should define behavior, HTML should define content, and CSS should define appearance.
- Any mixing of these responsibilities can lead to difficult-to-debug errors and maintenance issues.

As the amount of JavaScript has increased in web applications, performance has become more important. Therefore, you should keep these things in mind:

- The amount of time it takes JavaScript to execute directly affects the overall performance of a web page, so its importance cannot be dismissed.

- A lot of the performance recommendations for C-based languages also apply to JavaScript relating to loop performance and using switch statements instead of `if`.
- Another important thing to remember is that DOM interactions are expensive, so you should limit the number of DOM operations.

The last step in the process is deployment. Here are some key points discussed in this chapter:

- To aid in deployment, you should set up a build process that combines JavaScript files into a small number of files (ideally just one).
- Having a build process also gives you the opportunity to automatically run additional processes and filters on the source code. You can, for example, run a JavaScript verifier to ensure that there are no syntax errors or potential issues with the code.
- A compressor can get your files as small as possible before deployment.
- Coupling that with HTTP compression ensures that the JavaScript files are as small as possible and will have the least possible impact on overall page performance.

A

ES2018 and ES2019

Beginning with ECMAScript 2015, the TC-39 committee moved to begin releasing a new ECMA specification each year. Doing so allows them to collect all individual proposals that are at a sufficiently advanced stage and package them as a single bundle. This packaging is of limited importance, however, as browser vendors tend to adopt proposals in a piecemeal fashion. When a proposal has reached stage 4, its behavior will not change, it is likely to be included in the next ECMAScript release, and browsers will begin adopting the proposal's features at their discretion.

The ECMAScript 2018 proposal was finalized in January 2018 and features enhancements for asynchronous iteration, the rest and spread operators, regular expressions, and promises. TC-39 maintains a GitHub repository (<https://github.com/tc39/ecma262>) that you can use to track the status of various proposals:

TODO FIX ASYNC ITERATION

TODO ES2019 <http://exploringjs.com/es2018-es2019/toc.html>

NOTE *Because the features described in this chapter are so new, they will have limited browser support (if any at all). Consult <https://caniuse.com/> to determine if a browser version supports a certain feature.*

ASYNCHRONOUS ITERATION

Asynchronous execution and the iterator protocol are two extremely pervasive themes in new ECMAScript features over recent releases. Asynchronous execution involves releasing control of the execution thread to allow slow operations to finish before regaining control, and the iterator protocol involves defining a canonical ordering for arbitrary objects. Asynchronous iteration is merely the logical assimilation of these two concepts.

A synchronous iterator provides you with a { `value`, `done` } pair each time `next()` is invoked. Of course, this requires that the computation and resource fetching needed to determine the contents of this pair be completed by the time the `next()` invocation exits—otherwise, these values are indeterminate. When using a *synchronous* iterator to iterate over values that are

determined *asynchronously*, the main execution thread will be blocked while waiting for the asynchronous operation to complete.

With asynchronous iterators, this problem is totally solved. An asynchronous iterator provides you with a promise that resolves to a { value, done } pair each time next() is invoked. This way, the thread of execution can be released and perform work elsewhere while the current loop iteration is being resolved.

Creating and Using an Async Iterator

Async iterators are best understood through comparison with a traditional synchronous iterator. The following is a simple Emitter class, which contains a synchronous generator function that produces a synchronous iterator that will count from 0 to 4:

```
class Emitter {
  constructor(max) {
    this.max = max;
    this.syncIdx = 0;
  }

  *[Symbol.iterator]() {
    while(this.syncIdx < this.max) {
      yield this.syncIdx++;
    }
  }
}

const emitter = new Emitter(5);

function syncCount() {
  const syncCounter = emitter[Symbol.iterator]();

  for (const x of syncCounter) {
    console.log(x);
  }
}

syncCount();
// 0
// 1
// 2
// 3
// 4
```

The previous example only works because in each iteration, the next value is immediately able to be yielded. If instead you did not want to block the main thread of execution while determining the next value to yield, you can also define an asynchronous generator function that will yield Promise-wrapped values.

This can be accomplished using async-flavored versions of iterators and generators. ECMAScript 2018 defines `Symbol.asyncIterator`, which allows you to define and invoke Promise-yielding generator functions. The specification also introduces an asynchronous for loop iterator, the `for-await-of` loop, intended to consume this async iterator.

Using these, the previous example can be extended to support both synchronous and asynchronous iteration:

```

class Emitter {
  constructor(max) {
    this.max = max;
    this.syncIdx = 0;
    this.asyncIdx = 0;
  }

  *[Symbol.iterator]() {
    while(this.syncIdx < this.max) {
      yield this.syncIdx++;
    }
  }
  async *[Symbol.asyncIterator]() {
    *[Symbol.asyncIterator]() {
      while(this.asyncIdx < this.max) {
        yield new Promise((resolve) => resolve(this.asyncIdx++));
      }
    }
  }
}

const emitter = new Emitter(5);

function syncCount() {
  const syncCounter = emitter[Symbol.iterator]();

  for (const x of syncCounter) {
    console.log(x);
  }
}

async function asyncCount() {
  const asyncCounter = emitter[Symbol.asyncIterator]();

  for await(const x of asyncCounter) {
    console.log(x);
  }
}

syncCount();
// 0
// 1
// 2
// 3
// 4

asyncCount();
// 0
// 1
// 2
// 3
// 4

```

To further your understanding, swap out the above example so that the *synchronous* generator is passed to a for-await-of loop:

```
const emitter = new Emitter(5);

async function asyncIteratorSyncCount() {
  const syncCounter = emitter[Symbol.iterator]();

  for await (const x of syncCounter) {
    console.log(x);
  }
}

asyncIteratorSyncCount();
// 0
// 1
// AsyncIteratorExample01.js
2
// 3
// 4
```

Even though the sync counter iterates through primitive values, the for-await-of loop will handle the values as if they were returned wrapped in promises. This demonstrates the power of the for-await-of loop, which allows it to fluently handle both synchronous and asynchronous iterables. This is *not* true for a normal for loop, which cannot handle an asynchronous iterator:

```
function syncIteratorAsyncCount() {
  const asyncCounter = emitter[Symbol.asyncIterator]();

  for (const x of asyncCounter) {
    console.log(x);
  }
}

syncIteratorAsyncCount();
// TypeError: asyncCounter is not iterable
```

One of the most important concepts to understand about async iterators is that the `Symbol.asyncIterator` designation doesn't alter the behavior of the generator function or how the generator is consumed. Note that the generator function is defined as an async function, and designated as a generator using an asterisk. `Symbol.asyncIterator` merely suggests to an external construct such as a for-await-of loop that the associated iterator will return a sequence promise objects.

Understanding the Async Iterator Queue

Of course, the previous example is quite contrived, as the promises returned from the iterator are instantaneously resolved, and therefore it is little more than a thinly wrapped synchronous iterator. Suppose instead that the yielded promises resolved after an indeterminate period of time; what's more, suppose they return out of order. An asynchronous iterator should emulate a synchronous iterator in every way possible, including in-order execution of code associated with each iteration. To address this, asynchronous iterators maintain a queue of callbacks to ensure that the iterator handler

for an earlier value will always complete execution before proceeding to a later value, even if the later value resolves before the earlier value.

To prove this, the async iterator in the following example returns promises which resolve after a random period of time. The async iteration queue ensures that the promise resolution order does not interfere with the order of iteration. As a result, the integers will be printed in order (at random intervals):

```
class Emitter {
  constructor(max) {
    this.max = max;
    this.syncIdx = 0;
    this.asyncIdx = 0;
  }

  *[Symbol.iterator]() {
    while(this.syncIdx < this.max) {
      yield this.syncIdx++;
    }
  }

  async *[Symbol.asyncIterator]() {
    while(this.asyncIdx < this.max) {
      yield new Promise((resolve) => {
        setTimeout(() => {
          resolve(this.asyncIdx++);
        }, Math.floor(Math.random() * 1000));
      });
    }
  }
}

const emitter = new Emitter(5);

function syncCount() {
  const syncCounter = emitter[Symbol.iterator]();

  for (const x of syncCounter) {
    console.log(x);
  }
}

async function asyncCount() {
  const asyncCounter = emitter[Symbol.asyncIterator]();

  for await (const x of asyncCounter) {
    console.log(x);
  }
}

syncCount();
// 0
// 1
// 2
// 3
// 4
```

```
asyncCount();  
// 0  
// 1  
// 2  
// 3  
// 4  
AsyncIteratorExample02.js
```

Async Iterator reject() Handling

Because the composition of asynchronous iterators consists of promises, one must consider the possibility that one of the promises produced by the iterator will reject. Because the design of asynchronous iteration insists on in-order completion, it would not make sense to proceed past a rejected promise through the loop; therefore, a rejected promise will force the iterator to exit:

```
class Emitter {  
  constructor(max) {  
    this.max = max;  
    this.asyncIdx = 0;  
  }  
  
  async *[Symbol.asyncIterator]() {  
    while (this.asyncIdx < this.max) {  
      if (this.asyncIdx < 3) {  
        yield this.asyncIdx++;  
      } else {  
        throw 'Exited loop';  
      }  
    }  
  }  
}  
  
const emitter = new Emitter(5);  
  
async function asyncCount() {  
  const asyncCounter = emitter[Symbol.asyncIterator]();  
  
  for await (const x of asyncCounter) {  
    console.log(x);  
  }  
}  
  
asyncCount();  
// 0  
// 1  
// 2  
// Uncaught (in promise) Exited loop
```

Manual Async Iteration Using next()

The `for-await-of` loop offers two useful features: it makes use of the async iterator queue to ensure in-order execution, and it hides the promise structure of the async iterator. However, using such a loop conceals much of the underlying behavior.

Because the async iterator still follows the iterator protocol, you can just as easily progress through the async iterable using `next()`. As described earlier, `next()` contains a promise that will resolve to `{ value, done }`. This means that you must use the Promise API to retrieve methods, but it also means that you are not forced to use the async iterator queue.

```
const emitter = new Emitter(5);

const asyncCounter = emitter[Symbol.asyncIterator]();

console.log(asyncCounter.next());
// { value: Promise, done: false }
```

Top-Level Async Loops

As a rule, async behavior—including `for-await-of` loops—cannot exist outside of an async function. However, you may find it necessary on occasion to make use of async behavior in such a context. This can be accomplished by creating an async IIFE:

```
class Emitter {
  constructor(max) {
    this.max = max;
    this.asyncIdx = 0;
  }

  async *[Symbol.asyncIterator]() {
    while(this.asyncIdx < this.max) {
      yield new Promise((resolve) => resolve(this.asyncIdx++));
    }
  }
}

const emitter = new Emitter(5);

(async function() {
  const asyncCounter = emitter[Symbol.asyncIterator]();

  for await(const x of asyncCounter) {
    console.log(x);
  }
})();
// 0
// 1
// 2
// 3
// 4
```

Implementing Observables

Because asynchronous iterators will patiently wait for the next iteration without incurring computational cost, an entirely new avenue for implementing an observable interface opens up. At a high level, this will take the form of capturing events, wrapping them in promises, and then feeding these events through the iterator to allow for the listener to hook into the asynchronous iterator. When an event is fired, the next promise in the async iterator will resolve with that event.

NOTE *The topic of observables is outside the scope of this book because they are largely implemented as third-party libraries. For further reading, look into the wildly popular RxJS library (<http://reactivex.io/rxjs/>).*

A simplistic example of this would be to capture an observable stream of browser events. This requires a queue of promises, each of which corresponds to a single event. The queue will also preserve the order in which events are generated, which is a desirable feature for this sort of problem.

```
class Observable {
  constructor() {
    this.promiseQueue = [];

    // Holds the resolver for the next promise in the queue
    this.resolve = null;

    // Pushes the initial promise on the queue which will
    // resolve with the first observed event
    this.enqueue();
  }

  // Create a new promise, save its resolve method, and
  // store it on the queue
  enqueue() {
    this.promiseQueue.push(
      new Promise((resolve) => this.resolve = resolve));
  }

  // Remove the promise at the front of the queue and
  // return it
  dequeue() {
    return this.promiseQueue.shift();
  }
}
```

To make use of this promise queue, define an asynchronous generator method on this class. This generator should work for any event type:

```
class Observable {
  constructor() {
    this.promiseQueue = [];

    // Holds the resolver for the next promise in the queue
    this.resolve = null;

    // Pushes the initial promise on the queue which will
    // resolve with the first observed event
    this.enqueue();
  }

  // Create a new promise, save its resolve method, and
  // store it on the queue
  enqueue() {
```

```

    this.promiseQueue.push(
      new Promise((resolve) => this.resolve = resolve));
  }

  // Remove the promise at the front of the queue and
  // return it
  dequeue() {
    return this.promiseQueue.shift();
  }

  async *fromEvent (element, eventType) {
    // Whenever an event is generated, resolve the promise
    // at the front of the queue with the event object and
    // enqueue another promise.
    element.addEventListener(eventType, (event) => {
      this.resolve(event);
      this.enqueue();
    });

    // Each resolved promise at the front of the queue will
    // yield the event object to the async iterator
    while (1) {
      yield await this.dequeue();
    }
  }
}

```

With this fully defined class, it is now trivial to define an observable on DOM elements. Suppose the page has a `<button>` inside it; you could capture a stream of `click` events on this button and log each of them to the console as follows:

```

class Observable {
  constructor() {
    this.promiseQueue = [];

    // Holds the resolver for the next promise in the queue
    this.resolve = null;

    // Pushes the initial promise on the queue which will
    // resolve with the first observed event
    this.enqueue();
  }

  // Create a new promise, save its resolve method, and
  // store it on the queue
  enqueue() {
    this.promiseQueue.push(
      new Promise((resolve) => this.resolve = resolve));
  }

  // Remove the promise at the front of the queue and
  // return it
  dequeue() {
    return this.promiseQueue.shift();
  }
}

```

```
async *fromEvent (element, eventType) {
  // Whenever an event is generated, resolve the promise
  // at the front of the queue with the event object and
  // enqueue another promise.
  element.addEventListener(eventType, (event) => {
    this.resolve(event);
    this.enqueue();
  });

  // Each resolved promise at the front of the queue will
  // yield the event object to the async iterator
  while (1) {
    yield await this.dequeue();
  }
}

(async function() {
  const observable = new Observable();

  const button = document.querySelector('button');
  const mouseClickedIterator = observable.fromEvent(button, 'click');

  for await (const clickEvent of mouseClickedIterator) {
    console.log(clickEvent);
  }
})();
```

REST AND SPREAD OPERATORS FOR OBJECT LITERALS

In the ECMAScript 2018 specification, all the elegance of rest and spread operators in arrays is now also available inside object literals. This allows you to merge objects or collect properties into new objects.

Rest Operator

The rest operator allows you to use a single rest operator when destructuring an object to collect all remaining unspecified enumerable properties into a single object. This can be done as follows:

```
const person = { name: 'Matt', age: 27, job: 'Engineer' };
const { name, ...remainingData } = person;

console.log(name); // Matt
console.log(remainingData); // { age: 27, job: 'Engineer' }
```

The rest operator can be used at most once per object literal and must be listed last. Because there can be only a single rest operator per object literal, it is possible to nest the rest operators. When nesting, because there is no ambiguity about which elements of the property subtree are allocated to any given rest operator, the resulting objects will never overlap with respect to their contents:

```
const person = { name: 'Matt', age: 27, job: { title: 'Engineer', level: 10 } };
const { name, job: { title, ...remainingJobData }, ...remainingPersonData } = person;
```

```

console.log(name);           // Matt
console.log(title);         // Engineer
console.log(remainingPersonData); // { age: 27 }
console.log(remainingJobData); // { level: 10 }

const { ...a, job } = person;
// SyntaxError: Rest element must be last element

```

The rest operator performs a shallow copy between objects, so object references will be copied instead of creating entire object clones:

```

const person = { name: 'Matt', age: 27, job: { title: 'Engineer', level: 10 } };

const { ...remainingData } = person;

console.log(person === remainingData); // false
console.log(person.job === remainingData.job); // true

```

The rest operator will copy all enumerable own properties, including symbols:

```

const s = Symbol();
const foo = { a: 1, [s]: 2, b: 3 };

const {a, ...remainingData} = foo;

console.log(remainingData);
// { b: 3, Symbol(): 2 }

```

Spread Operator

The spread operator allows you to join two objects together in a fashion similar to array concatenation. The spread operator applied to an inner object will perform a shallow copy of all enumerable own properties, including symbols, into the outer object:

```

const s = Symbol();
const foo = { a: 1 };
const bar = { [s]: 2 };

const foobar = {...foo, c: 3, ...bar};

console.log(foobar);
// { a: 1, c: 3 Symbol(): 2 }

```

The order in which the spread objects are listed matters for two reasons:

1. Objects track insertion order. The properties copied from spread objects will be performed in the order they are listed inside the object literal.
2. Objects will overwrite properties as duplicates are encountered. The last property encountered will be the one that assumes the value.

These ordering conventions are demonstrated here:

```

const foo = { a: 1 };
const bar = { b: 2 };

```

```
const foobar = {c: 3, ...bar, ...foo};

console.log(foobar);
// { c: 3, b: 2, a: 1 }

const baz = { c: 4 };

const foobarbaz = {...foo, ...bar, c: 3, ...baz };

console.log(foobarbaz);
// { a: 1, b: 2, c: 4 }
```

As with the rest operator, all copies performed are shallow:

```
const foo = { a: 1 };
const bar = { b: 2, c: { d: 3 } };

const foobar = {...foo, ...bar};

console.log(foobar.c === bar.c); // true
```

PROMISE FINALLY() DEFINITION

Formerly, there were only inelegant ways of defining behavior that would execute after a promise exits the “pending” state no matter the outcome. Usually, this would take the form of recycling the handler:

```
let resolveA, rejectB;

function finalHandler() {
  console.log('finished');
}

function resolveHandler(val) {
  console.log('resolved');
  finalHandler();
}

function rejectHandler(err) {
  console.log('rejected');
  finalHandler();
}

new Promise((resolve, reject) => {
  resolveA = resolve;
})
.then(resolveHandler, rejectHandler);

new Promise((resolve, reject) => {
  rejectB = reject;
})
.then(resolveHandler, rejectHandler);
```



```

resolveA();
rejectB();
// resolved
// finished
// rejected
// finished

```

With `Promise.prototype.finally()`, you are able to unify the shared handler. The `finally()` handler is not passed any arguments and does not know if it is handling a resolved or rejected promise. The preceding example can be refactored to the following:

```

let resolveA, rejectB;

function finalHandler() {
  console.log('finished');
}

function resolveHandler(val) {
  console.log('resolved');
}

function rejectHandler(err) {
  console.log('rejected');
}

new Promise((resolve, reject) => {
  resolveA = resolve;
})
.then(resolveHandler, rejectHandler)
.finally(finalHandler);

new Promise((resolve, reject) => {
  rejectB = reject;
})
.then(resolveHandler, rejectHandler)
.finally(finalHandler);

resolveA();
rejectB();
// resolved
// rejected
// finished
// finished

```

You'll note here that the order of logging has changed. Each `finally()` creates a new promise instance, and these new promises are added to the browser's microtask queue and only resolved after the preceding handler promises are resolved.

REGULAR EXPRESSION ENHANCEMENTS

ECMAScript 2018 features a handful of new bells and whistles for regular expressions.

dotAll Flag

One annoying quirk of regular expressions was that the single character match token (the period “.”) does not match line terminator characters, such as `\n` and `\r`, or non-BMP characters, such as emojis.

```
const text = `
foo
bar
`;

const re = /foo.bar/;

console.log(re.test(text)); // false
```

This proposal introduces the “s” flag (standing for singleline), which corrects for this behavior:

```
const text = `
foo
bar
`;

const re = /foo.bar/s;

console.log(re.test(text)); // true
```

Lookbehind Assertions

Regular expressions support both positive and negative lookahead assertions, which allow declaration of expectations following a matched segment:

```
const text = 'foobar';

// Positive lookahead
// Assert that a value follows, but do not capture
const rePositiveMatch = /foo(?=bar)/;
const rePositiveNoMatch = /foo(?=baz)/;

console.log(rePositiveMatch.exec(text));
// ["foo"]

console.log(rePositiveNoMatch.exec(text));
// null

// Negative lookahead
// Assert that a value does not follow, but do not capture
const reNegativeNoMatch = /foo(?!bar)/;
const reNegativeMatch = /foo(?!baz)/;

console.log(reNegativeNoMatch.exec(text));
// null

console.log(reNegativeMatch.exec(text));
// ["foo"]
```

The new proposal introduces the mirror image of these assertions, positive and negative lookbehinds. These work identically to lookahead assertions, with the exception that they work to inspect content preceding the matched segment:

```
const text = 'foobar';

// Positive lookbehind
// Assert that a value precedes, but do not capture
const rePositiveMatch = /^(?<=foo)bar/;
const rePositiveNoMatch = /^(?<=baz)bar/;

console.log(rePositiveMatch.exec(text));
// ["bar"]

console.log(rePositiveNoMatch.exec(text));
// null

// Negative behind
// Assert that a value does not precede, but do not capture
const reNegativeNoMatch = /^(?!foo)bar/;
const reNegativeMatch = /^(?!baz)bar/;

console.log(reNegativeNoMatch.exec(text));
// null

console.log(reNegativeMatch.exec(text));
// ["bar"]
```

Named Capture Groups

Typically, multiple capture groups were accessed by index, which was a terrific exercise in frustration because indices offer no context as to what they actually contain:

```
const text = '2018-03-14';

const re = /(\d+)-(\d+)-(\d+)/;

console.log(re.exec(text));
// ["2018-03-14", "2018", "03", "14"]
```

The proposal allows for associating a valid JavaScript identifier with a capture group that can then be retrieved from the groups property of the result:

```
const text = '2018-03-14';

const re = /(?<year>\d+)-(?<month>\d+)-(?<day>\d+)/;

console.log(re.exec(text).groups);
// { year: "2018", month: "03", day: "14" }
```

Unicode Property Escapes

The Unicode standard defines properties for each character. Character properties such as character name, categories, white space designation, and the script or language the character is defined inside are all available as character properties. Unicode property escapes allow you to use these properties inside regular expressions.

Some properties are binary, meaning they can be applied standalone. Examples of this are `Uppercase` and `White_Space`. Other properties behave as key/value pairs, where a property will correspond to a property value. An example of this is `Script_Extensions=Greek`.

A list of Unicode properties can be found at <http://unicode.org/Public/UNIDATA/PropertyAliases.txt>.

A list of Unicode property values can be found at <http://unicode.org/Public/UNIDATA/PropertyValueAliases.txt>.

Unicode property escapes in regular expressions can use `\p` to select a match, or `\P` to select a non-match:

```
const pi = String.fromCharCode(0x03C0);
const linereturn = `
`;

const reWhiteSpace = /\p{White_Space}/u;
const reGreek = /\p{Script_Extensions=Greek}/u;
const reNotWhiteSpace = /\P{White_Space}/u;
const reNotGreek = /\P{Script_Extensions=Greek}/u;

console.log(reWhiteSpace.test(pi));           // false
console.log(reWhiteSpace.test(linereturn));   // true
console.log(reNotWhiteSpace.test(pi));        // true
console.log(reNotWhiteSpace.test(linereturn)); // false

console.log(reGreek.test(pi));                // true
console.log(reGreek.test(linereturn));        // false
console.log(reNotGreek.test(pi));             // false
console.log(reNotGreek.test(linereturn));     // true
```

ARRAY FLATTENING METHODS

ECMAScript 2019 added two methods to the `Array` prototype, `flat()` and `flatMap()`, which make array flattening operations much easier. Without these methods, flattening arrays is a nasty business which involved either an iterative or recursive solution.

NOTE `flat()` and `flatMap()` are strictly limited to flattening nested arrays. Nested iterable objects such as `Map` and `Set` will not be flattened.

Array.prototype.flatten()

The following is an example of how a simple recursive implementation might look without using these new methods:

```
function flatten(sourceArray, flattenedArray = []) {
  for (const element of sourceArray) {
    if (Array.isArray(element)) {
      flatten(element, flattenedArray);
    } else {

```

```

        flattenedArray.push(element);
    }
}

return flattenedArray;
}

const arr = [[0], 1, 2, [3, [4, 5]], 6];

console.log(flatten(arr))
// [0, 1, 2, 3, 4, 5, 6]

```

In many ways, this example resembles a tree data structure; each element in an array behaves like a child node, and non-array elements are leaves. Therefore, in this example the input array is a tree of height 2 with 7 leaves. Flattening this array is in essence an in-order traversal of the leaves.

It is sometimes useful to be able to specify how many levels of array nesting should be flattened. Consider the following example which modifies the initial implementation and allows for the flattening depth to be specified:

```

function flatten(sourceArray, depth, flattenedArray = []) {
  for (const element of sourceArray) {
    if (Array.isArray(element) && depth > 0) {
      flatten(element, depth - 1, flattenedArray);
    } else {
      flattenedArray.push(element);
    }
  }

  return flattenedArray;
}

const arr = [[0], 1, 2, [3, [4, 5]], 6];

console.log(flatten(arr, 1));
// [0, 1, 2, 3, [4, 5], 6]

```

To address these use cases, the `Array.prototype.flat()` method was added. This method accepts a `depth` argument (defaulting to a depth of 1) and returns a shallow copy of the `Array` instance flattened to the specified depth. This is demonstrated here:

```

const arr = [[0], 1, 2, [3, [4, 5]], 6];

console.log(arr.flat(2));
// [0, 1, 2, 3, 4, 5, 6]

console.log(arr.flat());
// [0, 1, 2, 3, [4, 5], 6]

```

Because a shallow copy is performed, arrays with cycles will copy values from the source array when flattening:

```

const arr = [[0], 1, 2, [3, [4, 5]], 6];

arr.push(arr);

```

```
console.log(arr.flat());
// [0, 1, 2, 3, 4, 5, 6, [0], 1, 2, [3, [4, 5]], 6]
```

Array.prototype.flatMap()

The `Array.prototype.flatMap()` method allows you to perform a map operation before flattening the array. `arr.flatMap(f)` is functionally equivalent to `arr.map(f).flat()`, but `arr.flatMap()` is more efficient since the browser only must perform a single traversal.

The function signature of `flatMap()` is identical to `map()`. A simple example is as follows:

```
const arr = [[1], [3], [5]];

console.log(arr.map((x) => [x, x + 1]));
// [[1, 2], [3, 4], [5, 6]]

console.log(arr.flatMap((x) => [x, x + 1]));
// [1, 2, 3, 4, 5, 6]
```

`flatMap()` is especially useful in situations where a non-array object's method returns an array, such as `split()`. Consider the following example, where a collection of input strings is split into words and joined into a single word array:

```
const arr = ['Lorem ipsum dolor sit amet,', 'consectetur adipiscing elit.'];

console.log(arr.flatMap((x) => x.split(/[W+]/)));
// ["Lorem", "ipsum", "dolor", "sit", "amet", "", "consectetur", "adipiscing",
"elit", ""]
```

A handy trick (albeit one which may incur a performance hit) is to use an empty array to filter out results after a map. The following example extends the above example to strip out the empty strings:

```
const arr = ['Lorem ipsum dolor sit amet,', 'consectetur adipiscing elit.'];

console.log(arr.flatMap((x) => x.split(/[W+]/)).flatMap((x) => x || []));
// ["Lorem", "ipsum", "dolor", "sit", "amet", "consectetur", "adipiscing", "elit"]
```

Here, each empty string in the results is first mapped to an empty array. When flattening, these empty arrays are effectively skipped in the array which is eventually returned.

NOTE *This strategy is not recommended, as each value to be filtered requires construction of a new Array instance that is immediately discarded.*

OBJECT.FROMENTRIES()

ECMAScript 2019 added a static method `fromEntries()` to the `Object` class which builds an object from a collection of key-value array pairs. This method performs the opposite operation of `Object.entries()`. This method is demonstrated here:

```
const obj = {
  foo: 'bar',
```

```

    baz: 'qux'
  };

const objEntries = Object.entries(obj);

console.log(objEntries);
// [{"foo", "bar"}, {"baz", "qux"}]

console.log(Object.fromEntries(objEntries));
// { foo: "bar", baz: "qux" }

```

The static method expects an iterable object containing any number of iterable objects of size 2. This is especially useful in cases where you wish to convert a `Map` instance to an `Object` instance, as the `Map` iterator's output exactly matches the signature that `fromEntries()` ingests:

```

const map = new Map().set('foo', 'bar');

console.log(Object.fromEntries(map));
// { foo: "bar" }

```

STRING TRIMMING METHODS

ECMAScript 2019 added two methods to the `String` prototype, `trimStart()` and `trimEnd()`, which allow for targeted whitespace removal. These methods are intended to replace `trimLeft()` and `trimRight()` which have ambiguous meaning in the context of right-to-left languages such as Arabic and Hebrew.

These two methods are effectively the opposite of `padStart()` and `padEnd()` with a single space character. The following example adds whitespace to a string and then removes it on either side:

```

let s = '  foo  ';

console.log(s.trimStart()); // "foo  "
console.log(s.trimEnd());  // "  foo"

```

SYMBOL.PROTOTYPE.DESCRPTION

ECMAScript 2019 added the ability to inspect the optional `Symbol` description via the `description` property. Formerly, this was only available when the symbol was casted to a string:

```

const s = Symbol('foo');

console.log(s.toString());
// Symbol(foo)

```

With the ES2019 addition, each `Symbol` object has a read-only `description` property which exposes the description. If there is no description, this default to `undefined`.

```

const s = Symbol('foo');

console.log(s.description);
// foo

```

OPTIONAL CATCH BINDING

Prior to ES2019, the structure of a try/catch block was fairly rigid. Even if you did not wish to use the error object caught, the parser still required you to assign the error object a variable name inside the catch clause:

```
try {
  throw 'foo';
} catch (e) {
  // An error happened, but you don't care about the error object
}
```

In ES2019, you are now able to omit the error object assignment and simply ignore the error entirely:

```
try {
  throw 'foo';
} catch {
  // An error happened, but you don't care about the error object
}
```

MISCELLANEOUS ENHANCEMENTS

ES2019 also introduces a handful of tweaks to existing tooling:

- `Array.prototype.sort()` is *stable*, meaning that equivalent objects will not be reordered in the output.
- Lone UTF-16 surrogate characters cannot be encoded in UTF-8, which causes problems with `JSON.stringify()`. Rather than return unpaired surrogate code points as single UTF-16 code units, they are now represented with JSON escape sequences.
- Previously, both U+2028 LINE SEPARATOR and U+2029 PARAGRAPH SEPARATOR were valid in JSON strings but invalid in ECMAScript strings. ES2019 introduces compatibility between ECMAScript strings and JSON strings.
- Formerly, browser vendors had lots of room to specify what was returned from `Function.prototype.toString()`. ES2019 requires that this method return the function's source code whenever possible, otherwise `{ [native code] }`.

B

Strict Mode

ECMAScript 5 was the first to introduce the concept of *strict mode*. Strict mode allows you to opt-in to stricter checking for JavaScript error conditions either globally or locally within a single function. The advantage of strict mode is that you'll be informed of errors earlier, so some of the ECMAScript quirks that cause programming errors will be caught immediately.

The rules of strict mode are important to understand, as future versions of ECMAScript will mandate the increasingly pervasive use of strict mode. Strict mode is supported in all major browsers.

OPTING-IN

To opt-in to strict mode, use the strict mode *pragma*, which is simply a string that isn't assigned to any variable:

```
"use strict";
```

Using this syntax, which is valid even in ECMAScript 3, allows seamless fallback for JavaScript engines that don't support strict mode. The engines that support strict mode will enable it, while engines that don't will simply ignore the pragma as an unassigned string literal.

When the pragma is applied globally, outside of a function, strict mode is enabled for the entire script. That means adding the pragma to a single script that is concatenated with other scripts into a single file puts all JavaScript in the file into strict mode.

You can also turn on strict mode within a function only, such as:

```
function doSomething() {  
    "use strict";  
    // other processing  
}
```

If you don't have complete control over all of the scripts on a page, then it's advisable to enable strict mode only within specific functions for which it has been tested.

VARIABLES

How and when variables get created is different in strict mode. The first change disallows accidental creation of global variables. In nonstrict mode, the following creates a global variable:

```
// Variable is not declared
// Non-strict mode: creates a global
// Strict mode: Throws a ReferenceError
message = "Hello world!";
```

Even though `message` isn't preceded by the `let` keyword and isn't explicitly defined as a property of the global object, it is still automatically created as a global. In strict mode, assigning a value to an undeclared variable throws a `ReferenceError` when the code is executed.

A related change is the inability to call `delete` on a variable. Nonstrict mode allows this and may silently fail (returning `false`). In strict mode, an attempt to delete a variable causes an error:

```
// Deleting a variable
// Non-strict mode: Fails silently
// Strict mode: Throws a ReferenceError
let color = "red";
delete color;
```

Strict mode also imposes restrictions on variable names. Specifically, it disallows variables named `implements`, `interface`, `let`, `package`, `private`, `protected`, `public`, `static`, and `yield`. These are now reserved words that are intended for use in future ECMAScript editions. Any attempt to use these as variable names while in strict mode will result in a syntax error.

OBJECTS

In strict mode, object manipulation is more likely to throw errors than in nonstrict mode. Strict mode tends to throw errors in situations where nonstrict mode silently fails, increasing the likelihood of catching an error early on in development.

To begin, there are several cases where attempting to manipulate an object property will throw an error:

- Assigning a value to a read-only property throws a `TypeError`.
- Using `delete` on a nonconfigurable property throws a `TypeError`.
- Attempting to add a property to a nonextensible object throws a `TypeError`.

Another restriction on objects has to do with declaring them via object literals. When using an object literal, property names must be unique. For instance:

```
// Two properties with the same name
// Non-strict mode: No error, second property wins
// Strict mode: Throws a syntax error
let person = {
  name: "Nicholas",
  name: "Greg"
};
```

The object literal for `person` has two properties called `name` in this code. The second property is the one that ends up on `person` in nonstrict mode. In strict mode, this is a syntax error.

NOTE *The restriction on duplicate property names was removed in ECMAScript 6. Duplicate object literal property keys do not throw an error in strict mode.*

FUNCTIONS

First, strict mode requires that named function arguments be unique. Consider the following:

```
// Duplicate named arguments
// Non-strict mode: No error, only second argument works
// Strict mode: Throws a SyntaxError
function sum (num, num){
    // do something
}
```

In nonstrict mode, this function declaration doesn't throw an error. You'll be able to access the second `num` argument only by name while the first is accessible only through `arguments`.

The `arguments` object also has a slight behavior change in strict mode. In nonstrict mode, changes to a named argument are also reflected in the `arguments` object, whereas strict mode ensures that each are completely separate. For example:

```
// Change to named argument value
// Non-strict mode: Change is reflected in arguments
// Strict mode: Change is not reflected in arguments
function showValue(value){
    value = "Foo";
    alert(value);           // "Foo"
    alert(arguments[0]);   // Non-strict mode: "Foo"
                          // Strict mode: "Hi"
}
showValue("Hi");
```

In this code, the function `showValue()` has a single named argument called `value`. The function is called with an argument of `"Hi"`, which is assigned to `value`. Inside the function, `value` is changed to `"Foo"`. In nonstrict mode, this also changes the value in `arguments[0]`, but in strict mode they are kept separate.

Another change is the elimination of `arguments.callee` and `arguments.caller`. In nonstrict mode, these refer to the function itself and the calling function, respectively. In strict mode, attempting to access either property throws a `TypeError`. For example:

```
// Attempt to access arguments.callee
// Non-strict mode: Works as expected
// Strict mode: Throws a TypeError
function factorial(num){
    if (num <= 1) {
```

```

    return 1;
  } else {
    return num * arguments.callee(num-1)
  }
}
let result = factorial(5);

```

Similarly, the `caller` and `arguments` properties of a function now throw a `TypeError` when an attempt is made to read or write them. So in this example, attempts to access `factorial.caller` and `factorial.callee` would also throw an error.

Also, as with variables, strict mode imposes restrictions on function names, disallowing functions named `implements`, `interface`, `let`, `package`, `private`, `protected`, `public`, `static`, and `yield`.

The last change to functions is disallowing function declarations unless they are at the top level of a script or function. That means functions declared, for instance, in an `if` statement are now a syntax error:

```

// Function declaration in an if statement
// Non-strict mode: Function hoisted outside of if statement
// Strict mode: Throws a syntax error
if (true){
  function doSomething(){
    // ...
  }
}

```

This syntax is tolerated on all browsers in nonstrict mode but will now throw a syntax error in strict mode.

Function Parameters

ES6 introduced the rest operator, destructured parameters, and default parameters—a robust collection of new abilities for functions to organize, structure, and define their parameters. A small change introduced in ECMAScript 7 dictates that functions that use any of these advanced parameter features cannot use strict mode inside its function body without throwing an error. Use of global strict mode is still allowed.

```

// ok
function foo(a, b, c) {
  "use strict";
}

// bad
function bar(a, b, c='d') {
  "use strict";
}

// bad
function baz({a, b, c}) {
  "use strict";
}

```

```
// bad
function gux(a, b, ...c) {
  "use strict";
}
```

The new features introduced in ES6 expect that the parameters will be parsed in the same mode as the function body. Because the "use strict" pragma is encountered inside the function body, the JavaScript parser would need to check for a pragma inside the function body before ingesting the function parameters, introducing a great deal of messiness. Therefore, the ES7 specification introduced this convention in order to allow the parser to definitively know what mode it is operating in before it begins to parse the function.

eval()

The much-maligned `eval()` function receives an upgrade in strict mode. The biggest change to `eval()` is that it will no longer create variables or functions in the containing context. For example:

```
// eval() used to create a variable
// Non-strict mode: Alert displays 10
// Strict mode: Throws an ReferenceError when alert(x) is called
function doSomething(){
  eval("let x = 10");
  alert(x);
}
```

When run in nonstrict mode, this code creates a local variable `x` in the function `doSomething()` and that value is then displayed using `alert()`. In strict mode, the call to `eval()` does not create the variable `x` inside of `doSomething()` and so the call to `alert()` throws a `ReferenceError` because `x` is undeclared.

Variables and functions can be declared inside of `eval()`, but they remain inside a special scope that is used while code is being evaluated and then destroyed once completed. So the following code works without any errors:

```
"use strict";
let result = eval("let x = 10, y = 11; x + y");
alert(result); // 21
```

The variables `x` and `y` are declared inside of `eval()` and are added together before returning their value. The `result` variable then contains 21, the result of adding `x` and `y`, even though `x` and `y` no longer exist by the time `alert()` is called.

eval AND ARGUMENTS

Strict mode now explicitly disallows using `eval` and `arguments` as identifiers and manipulating their values. For example:

```
// Redefining eval and arguments as variables
// Non-strict mode: Okay, no error.
// Strict-mode: Throws syntax error
let eval = 10;
let arguments = "Hello world!";
```

In nonstrict mode, you can overwrite `eval` and assign arguments to a value. In strict mode, this causes a syntax error. You can't use either as an identifier, which means all of the following use cases throw a syntax error:

- Declaration using `let`
- Assignment to another value
- Attempts to change the contained value, such as using `++`
- Used as function names
- Used as named function arguments
- Used as exception name in `try-catch` statement

COERCION OF THIS

One of the biggest security issues, and indeed one of the most confusing aspects of JavaScript, is how the value of `this` is coerced in certain situations. When using the `apply()` or `call()` methods of a function, a `null` or `undefined` value is coerced to the global object in nonstrict mode. In strict mode, the `this` value for a function is always used as specified, regardless of the value. For example:

```
// Access a property
// Non-strict mode: Accesses the global property
// Strict mode: Throws an error because this is null
let color = "red";
function displayColor() {
  alert(this.color);
}
displayColor.call(null);
```

This code passes `null` to `displayColor.call()`, which in nonstrict mode means the `this` value of the function is the global object. The result is an alert displaying "red". In strict mode, the `this` value of the function is `null`, so it throws an error when attempting to access a property of a `null` object.

Typically, functions will coerce their `this` value into an object type, a behavior colloquially referred to as “boxing.” Primitives will be coerced into their object wrapper equivalents.

```
function foo() {
  console.log(this);
}

foo.call(); // Window {}
foo.call(2); // Number {2}
```

When executed in strict mode, the `this` value will no longer undergo this boxing:

```
function foo() {
  "use strict";
  console.log(this);
}

foo.call(); // undefined
foo.call(2); // 2
```

CLASSES AND MODULES

Classes and modules are two mediums of code containers introduced in ECMAScript 6. There is no concept of an ECMAScript predecessor for either of these, and therefore there is no need to support syntactical compatibility with legacy ECMAScript versions. Therefore, TC-39 decided that all code defined inside ES6 classes and modules by default is in strict mode.

For classes, this includes both class declarations and class expressions; the constructor, instance methods, static methods, getters, and setters are all in strict mode. For modules, all code defined inside them will be in strict mode.

OTHER CHANGES

There are several other changes to strict mode of which you need to be aware. The first is the elimination of the `with` statement. The `with` statement changes how identifiers are resolved and has been removed from strict mode as a simplification. An attempt to use `with` in strict mode results in a syntax error.

```
// Use of the with statement
// Non-strict mode: Allowed
// Strict mode: Throws a syntax error
with(location) {
  alert(href);
}
```

Strict mode also eliminates the *octal literal* from JavaScript. Octal literals begin with a zero and have traditionally been the source of many errors. An octal literal is now considered invalid syntax in strict mode.

```
// Use of octal literal
// Non-strict mode: value is 8.
// Strict mode: throws a syntax error.
let value = 010;
```

ECMAScript 5 changed `parseInt()` for nonstrict mode, where octal literals are now considered decimal literals with a leading zero. For example:

```
// Use of octal literal in parseInt()
// Non-strict mode: value is 8
// Strict mode: value is 10
let value = parseInt("010");
```

C

JavaScript Libraries and Frameworks

JavaScript *libraries* help to bridge the gap between browser differences and provide easier access to complex browser features. Libraries come in two forms: *general* and *specialty*. General JavaScript libraries provide access to common browser functionality and can be used as the basis for a website or web application. Specialty libraries do only specific things and are intended to be used for only parts of a website or web application. This appendix provides an overview of these libraries and some of their functionality, along with websites that you can use as additional resources.

FRAMEWORKS

The “framework” designation covers a spectrum of different patterns, but in some form they all provide an opinionated organizational structure within which complex applications can take shape. Using a framework allows for applications to maintain consistent code conventions while elegantly scaling in size and complexity. They offer robust mechanisms for common tasks such as component definition and reuse, controlling data flow, routing, and many others.

Increasingly, JavaScript frameworks take the form of a *single page application* (SPA). Single page applications use the HTML5 browser history API to offer an entire application user interface, complete with URL routing, with only a single initial page load. The framework manages the application state as well as all the user interface components during the application’s execution. Most popular SPA frameworks have strong developer communities as well as an abundance of third-party extensions.

React

Created by Facebook, the React framework covers the “view” component in the Model-View-Controller model. Its limited purview means it can be used in conjunction with other frameworks or React extensions to attain full MVC coverage. React uses unidirectional data flow, is declarative and component-based, uses a virtual DOM to efficiently rerender the page, and

offers a JSX syntax, which allows you to write markup inside JavaScript. Facebook also maintains a complementary framework to React, named “Flux.”

License: MIT License

Website: <https://reactjs.org/>

Angular

First released in 2010 by Google, the Angular project is a full-featured web application framework for Model-View-Viewmodel architectures. In 2016, the project forked into two branches: Angular 1.x, which is a continuation of the original AngularJS project, and Angular 2, which is a wholly redesigned framework that is built around ES6 constructs and TypeScript. The latest releases of both versions are directive and component-based implementations, and both projects enjoy robust developer communities and third-party add-ons.

License: MIT License

Websites: <https://angularjs.org/> and <https://angular.io/>

Vue

Vue is a full-featured web application framework designed to be less opinionated than frameworks like Angular. Since its release in 2014, its developer community has grown mightily, and many developers reach for Vue because of its ability to offer performance and organizational gains while allowing for less rigorous adhesion to its tenets.

License: MIT License

Website: <https://vuejs.org/>

Ember

Ember is very similar to Angular in that it is also a Model-View-Viewmodel architecture and uses preferred conventions to fill out a web application. The 2.0 release in 2015 introduced many behavioral characteristics used by the React framework.

License: MIT License

Website: <https://emberjs.com/>

Meteor

Meteor is wholly unlike any other framework in this list because it is an isomorphic JavaScript framework, meaning that client and server share a codebase. It also uses a real-time data updating protocol, which continually pushes fresh data changes from DB to client. Meteor is an extremely opinionated framework; however, the benefit of this is that application features can be developed quickly using its robust out-of-the-box featureset.

License: MIT License

Website: <http://meteor.com/>

Backbone.js

A minimal Model-View-Controller (MVC) open-source library built on top of Underscore.js, *Backbone.js* is optimized for single-page applications, enabling you to easily update parts of the page as application state changes.

License: MIT License

Website: <http://backbonejs.org/>

GENERAL LIBRARIES

General JavaScript libraries provide functionality that spans across topics. All general libraries seek to equalize browser interface and implementation differences by wrapping common functionality with new APIs. Some of the APIs look similar to native functionality, whereas others look completely different. General libraries typically provide interaction with the DOM, support for Ajax, and utility methods that aid in common tasks.

jQuery

jQuery is an open-source library that provides a functional programming interface to JavaScript. It is a complete library whose core is built around using CSS selectors to work with DOM elements. Through call chaining, jQuery code looks more like a narrative description of what should happen rather than JavaScript code. This style of code has become popular among designers and prototypers.

License: MIT License or General Public License (GPL)

Website: <http://jquery.com/>

Google Closure Library

The Google Closure Library is an all-purpose JavaScript toolkit, similar in many ways to jQuery. It consists of an extremely broad set of modules covering both low-level operations and high-level components and widgets. The Closure Library is designed so that modules can be included as necessary, and the library is built to work alongside the Google Closure Compiler (covered in Appendix D, “JavaScript Tools”).

License: Apache 2.0

Website: <https://developers.google.com/closure/library/>

Underscore.js

While not strictly a general library, *Underscore.js* does provide some additional functionality for functional programming in JavaScript. The documentation talks about Underscore.js as a complement to jQuery, providing additional low-level functionality for working with objects, arrays, functions, and other JavaScript data types.

License: MIT License

Website: <http://documentcloud.github.com/underscore/>

Lodash

In the same category as Underscore.js, Lodash is also a utility library that provides you with a supplementary JavaScript toolkit. It introduces enhanced methods for native types, such as arrays, objects, functions, and primitives.

License: MIT License

Website: <https://lodash.com/>

Prototype

Prototype is an open-source library that provides simple APIs for common web tasks. Originally developed for use in Ruby on Rails, Prototype is class-driven, aiming to provide class definition and inheritance for JavaScript. To that end, Prototype provides a number of classes that encapsulate common and complex functionality into simple API calls. As a single file, Prototype can be dropped into any page with ease.

License: MIT License and Creative Commons Attribution-Share Alike 3.0 Unported

Website: www.prototypejs.org/

The Dojo Toolkit

In the *Dojo Toolkit*, an open-source library modeled on a package system, groups of functionality are organized into packages that can be loaded on demand. Dojo provides a wide range of options and configurations, covering almost anything you want to do with JavaScript.

License: “New” BSD License or Academic Free License version 2.1

Website: www.dojotoolkit.org/

MooTools

An open-source library designed to be compact and optimized, *MooTools* adds methods to native JavaScript objects to provide new functionality on familiar interfaces and to provide new objects. Its small size and simple API make MooTools a favorite among web developers.

License: MIT License

Website: www.mootools.net/

qooxdoo

qooxdoo is an open-source library that aims to help with the entire web-application development cycle. qooxdoo implements its own versions of classes and interfaces to create a programming model similar to traditional object-oriented (OO) languages. The library includes a full GUI toolkit and compilers for simplifying the front-end build process. qooxdoo began as an internal library for the 1&1 web-hosting company (www.1and1.com) and later was released under an open-source license.

License: GNU Lesser General Public License (LGPL) or Eclipse Public License (EPL)

Website: www.qooxdoo.org/

ANIMATION AND EFFECTS

Animation and other visual effects have become a big part of web development. Getting smooth animation out of web pages can be a difficult task, and several library developers have stepped up to provide easy-to-use and smooth animation and effects. Many of the general JavaScript libraries mentioned previously also feature animation.

D3

Easily the most popular animation library, D3 (for “Data Driven Documents”) is the most robust and powerful JavaScript data visualization tool in use today. It has an intensely deep featureset, covering canvas, SVG, CSS, and HTML5 visualizations. The library gives you the capability to control the final rendering with extreme precision.

License: BSD

Website: www.d3js.org/

three.js

three.js is one of the most popular WebGL libraries available. It offers a lightweight API that allows you to perform complex 3D renderings and animations.

License: MIT License

Website: <https://threejs.org>

moo.fx

The *moo.fx* open-source animation library is designed to work on top of either Prototype or MooTools. Its goal is to be as small as possible (the latest version is 3 KB) and to allow developers to create animations while writing as little code as necessary. moo.fx is included with MooTools by default; it can also be downloaded separately for use with Prototype.

License: MIT License

Website: <http://moofx.mad4milk.net/>

Lightbox

Lightbox, a JavaScript library for creating simple image overlays on any page, requires both Prototype and script.aculo.us to create its visual effects. The basic idea is to allow users to view an image or a series of images in an overlay without leaving the current page. The “lightbox” overlay is customizable in both appearance and transitions.

License: Creative Commons Attribution 2.5 License

Website: www.huddletogether.com/projects/lightbox2/

D

JavaScript Tools

Writing JavaScript is a lot like writing in any other programming language, with tools designed to make development easier. The number of tools available for JavaScript developers continues to grow, making it much easier to locate problems, optimize, and deploy JavaScript-based solutions. Some of the tools are designed to be used from JavaScript, whereas others can be run outside the browser. This appendix provides an overview of some of these tools, as well as additional resources for more information.

NOTE *You will notice that various tools are included in multiple sections throughout this appendix. Many JavaScript tools available today are meant to be all-in-one project management tools, and thus they relate to multiple domains.*

PACKAGE MANAGERS

JavaScript projects will usually need to leverage third-party libraries and assets to avoid code duplication and speed development. Third-party libraries, referred to as “packages,” are hosted on publicly available repositories. Packages can take the form of assets that will be delivered to the browser, JavaScript libraries that will be compiled as part of your project, or even tools for your project development pipeline. These packages are almost always actively developed and undergoing revisions, in addition to having different flavors of releases. JavaScript package managers allow you to manage what packages your projects depend on, how to access and install them, and which versions to install.

Package managers offer a command line interface for installing or removing project dependencies. The project’s configuration will usually be stored in a local project manifest file.

npm

npm, which stands for “Node Package Manager,” is the default package manager for the NodeJS runtime. Third-party packages—provided inside the npm registry—can be specified as project dependencies and installed locally via the command line. npm’s repository contains both server-side and client-side JavaScript packages.

npm is designed for use on a server, where the size of a dependency graph is less critical. When installing packages, npm uses a nested dependency tree to resolve all project dependencies; each project dependency will install its own version of whatever other packages it depends on. This means that if your project has three package dependencies—A, B, and C—and each of those depends on a different version of package D, npm will install three separate versions of package D, one for each dependency.

Website: <https://www.npmjs.com/>

Bower

Bower features many of the same rhythms as npm, including package installation and management CLI, but its focus is on managing packages that will be served to a client. One major difference between Bower and npm is that Bower uses a flat dependency structure. This means that project dependencies will share packages they depend on, and the user's job is to resolve these dependencies. For example, if your project has three package dependencies—A, B, and C—and each of those depends on a different version of package D, you will need to find a single version of package D that satisfies the requirements of all these packages because the flat dependency structure dictates that you install a single version of any given package.

Website: <https://bower.io/>

JSPM

JSPM is a package manager built around using SystemJS for dynamic module loading. The package manager itself is similar to npm but is registry agnostic; packages from the npm registry, Github, or even custom registries can all be installed together using its CLI. Instead of bundling and precompiling assets on the server, JSPM allows you to dynamically serve packages to the client as needed through SystemJS. Like Bower, it uses a flat dependency structure.

Website: <https://jspm.io/>

Yarn

Developed by Facebook, Yarn is a custom package manager that is, in many ways, a souped-up version of npm. It can access all the same npm packages through the Yarn registry, and it installs them in much the same way as npm. The primary differences between Yarn and npm is that the former offers features that afford you faster installs, package caching, lockfiles, and improved package security features.

Website: <https://yarnpkg.com/>

MODULE LOADERS

Module loaders allow you to request modules from the server on demand as opposed to loading every single JS module or a single bundled JS file all at once. The ECMAScript 6 module specification outlines an eventual target for browsers to natively support dynamic module loading. Presently, many browsers still do not support ES6 module loading, and therefore module loaders serve as a sort of polyfill that allows for packages to dynamically load modules from the client.

SystemJS

The SystemJS module loader is geared for either server or client use. It supports all module formats, including AMD, CommonJS, UMD, and ES6. It also supports in-browser transpilation (not recommended for large-scale projects because of performance implications).

Website: <https://github.com/systemjs/>

RequireJS

RequireJS is built atop the AMD module specification and offers exceptional legacy browser support. Although RequireJS is tried and true, the JavaScript community as a whole is largely leaving the AMD module format behind, so beginning a large project with RequireJS is not recommended.

Website: <http://requirejs.org/>

MODULE BUNDLERS

Module bundlers allow you to combine an arbitrary number of modules in various module formats into bundles that can be loaded on the client. The module bundler will keep track of your application's dependency graph and order the modules as necessary. Frequently, the application can be served as a single bundle, but multiple bundle configurations are also possible. Module bundlers also often support bundling raw or compiled CSS assets. Bundles may take the form of a self-executing bundle, or they may remain as concatenated module assets, which will not execute until necessary.

Webpack

Featuring a broad featureset and excellent extensibility, Webpack is overwhelmingly the most popular application bundler in use today. It can bundle different module types, supports a wide array of plugins, and is fully compatible with most templating and transpilation libraries.

Website: <https://webpack.js.org/>

JSPM

JSPM is a package manager built around SystemJS and the ES6 module loader. One of JSPM's recommended production workflows is to bundle all your modules into a single file, which will then be loaded by SystemJS. This is available to you through the JSPM CLI.

Website: <https://jspm.io/>

Browserify

Browserify is a slightly older but widely used and battle-tested module bundler that supports the NodeJS-flavored CommonJS `require()` dependency syntax.

Website: <http://browserify.org/>

Rollup

Rollup is similar in many ways to Browserify in its module bundling abilities, but it also introduces tree shaking out-of-the-box. Rollup is able to parse your application's dependency graph and prune off any modules that are not actually used.

Website: <https://rollupjs.org/>

COMPILATION/TRANSPILATION TOOLS AND STATIC TYPE SYSTEMS

Web application code written in the editor is almost never the exact code that will be served to the client. Developers often want to leverage newer ECMAScript specification features that have yet to gain universal browser adoption. Furthermore, developers also often want to augment or enhance their codebase with a static type system or features outside the ECMA specification. There are a range of tools to address different aspects of these needs.

Babel

Babel is one of the most popular tools used for compiling the latest ECMAScript specification features down to a browser-friendly ECMA version. It also features support for React's JSX, accepts a wide range of plugins, and is compatible with all major build tools.

Website: <https://babeljs.io/>

Google Closure Compiler

Google's Closure Compiler is a powerful JavaScript compiler that is capable of varying levels of compilation optimization as well as a robust static type checking system. Type annotations are done in JSDoc-style comments.

Website: <https://developers.google.com/closure/>

CoffeeScript

CoffeeScript is an augmented ECMAScript syntax that compiles into regular JavaScript; almost everything in CoffeeScript is an expression. Its syntax enhancements are inspired by Ruby, Python, and Haskell.

Website: <http://coffeescript.org/>

TypeScript

Microsoft's TypeScript is a typed superset of JavaScript that introduces robust static type checking and major syntax enhancements. Because it is a strict superset of JavaScript, regular JS programs are valid TypeScript syntax. TypeScript also can use type definition files to specify type information for existing JavaScript libraries.

Website: <http://typescriptlang.org/>

Flow

Facebook's Flow is a simple type annotation system for JavaScript. Its type syntax is very similar to TypeScript, but it does not add additional language features other than type declarations.

Website: <https://flow.org/>

HIGH-PERFORMANCE SCRIPT TOOLS

A common criticism of JavaScript is that it is incredibly slow and inappropriate for computing that requires agility. Whether or not this “slow” designation carries water doesn't change the fact that the language was never built to support nimble computation. To address this, there are a number of projects that attempt to augment code execution paradigms in the browser in order to allow the program to execute at near native speeds and make use of hardware optimizations.

WebAssembly

The WebAssembly project (or *wasm*) is working to implement a language that can run in many locations (portable) and exist as a binary language that can be compiled to from multiple low-level languages such as C++ and Rust. WebAssembly code runs in a totally separate virtual machine from that of JavaScript in a browser, and its ability to interact with various browser APIs is extremely limited. It is possible to interact with JavaScript and the DOM in an indirect and limited fashion, but the bigger goal of WebAssembly is to create an extremely fast language that can run in web browsers (and elsewhere) and offer near-native performance and hardware acceleration. The WebAssembly specification is still being fleshed out and specified, but it is one of the most promising areas in browser technology.

Website: <http://webassembly.org/>

asm.js

asm.js is based around the idea that compiled JavaScript can be run much faster than handwritten JavaScript. asm.js is a subset of JavaScript that low-level language code can be compiled to and executed in a normal browser or Node engine. Modern JavaScript engines infer types at runtime, and asm.js code makes these type inferences (and therefore associated operations) much less computationally expensive by coercing types using lexical hints. It also makes extensive use of TypedArrays, which offer huge performance gains over the traditional associative JS array. asm.js is not as fast as WebAssembly, but it still offers significant performance gains through compilation.

Website: <http://asmjs.org/>

Emscripten and LLVM

While it never executes in the browser, Emscripten is a critical toolkit for compiling low-level code to WebAssembly and asm.js. Emscripten uses the LLVM compiler to compile languages such as C, C++, and Rust into code that can either run directly in the browser (asm.js) or in a virtual machine (WebAssembly).

Emscripten Website: <http://kripken.github.io/emscripten-site/>

LLVM Website: <http://llvm.org/>

EDITORS

VIM, Emacs, and their ilk are excellent text editors, but as your build environment and application scale in complexity it becomes increasingly useful for editors to automate common tasks such as autocompletion, file formatting, code linting, and project directory comprehension. A broad range of editors and IDEs that offer these features is available to choose from, both free and paid.

Sublime Text

Sublime Text is a wildly popular closed-source text editor. It can be used for developing in all languages, but it offers an extremely extensive library of plugins maintained by the community. The performance of the editor is among the best in its class.

Website: <https://sublimetext.com/>

Price: Free trial; one-time \$80 license

Atom

GitHub's Atom is an open-source text editor with many of the same features as Sublime Text, including a thriving community and third-party package add-ons. The editor sometimes struggles with performance, but it is continually making strides in this area.

Website: <https://atom.io/>

Price: Free

Brackets

Adobe's Brackets is similar to Atom in that it is open source, but the editor is designed specifically for web developers and offers a number of very impressive and unique features geared toward frontend coding. Accompanying it is a healthy library of plugins.

Website: <http://brackets.io/>

Price: Free

Visual Studio Code

Microsoft's Visual Studio Code is an open-source code editor based on the Electron framework. Similar to other major editors, it is highly extensible via its package library.

Website: <https://jetbrains.com/webstorm/>

Price: Free

WebStorm

JetBrains's WebStorm is an unapologetically high-octane IDE geared to be the ultimate project development toolkit, featuring robust integration with the leading frontend frameworks. It also integrates with most build tools and version control systems.

Website: <https://jetbrains.com/webstorm/>

Price: Free trial; monthly/yearly licensing fees

BUILD TOOLS, AUTOMATION SYSTEMS, AND TASK RUNNERS

The process of transforming a local project directory into an application served in production is usually bundled into a number of tasks. Each of these tasks is often composed of a pipeline of many subtasks—for example, building and deploying an application will involve module bundling, compilation, minification, and pushing static assets, among many other tasks. Running a unit or integration test might involve initialization of test harnesses and spinning up headless browsers. To make management and utilization of these tasks easier, there are a number of tools that allow you to more efficiently compose and organize your application’s tasks.

Grunt

Grunt is a NodeJS task runner that uses configuration objects to declaratively define how tasks should execute. It features a healthy community and a large selection of plugins from which to build out your project’s tasks.

Website: <https://gruntjs.com/>

Gulp

Similar to Grunt, Gulp is also a NodeJS task runner, which instead uses a Unix-style pipeline approach to task definition, where individual tasks are defined as JavaScript functions. Gulp also features a vibrant community and package library.

Website: <https://gulpjs.com/>

Brunch

Brunch is another NodeJS build tool that is designed for simplicity and ease of use as opposed to maximum configurability. It is newer than Gulp or Grunt, but still features a healthy selection of plugins.

Website: <http://brunch.io/>

npm

Although not strictly a build tool, npm offers a scripts feature, which many developers have found works nicely as a task runner that works out-of-the-box with no extra frills. Scripts are defined directly inside the NodeJS `package.json`.

Website: <https://docs.npmjs.com/misc/scripts/>

LINTERS AND FORMATTERS

Part of the problem with JavaScript debugging is that there aren’t many IDEs that automatically indicate syntax errors as you type. Most developers write some code and then load it into a browser to look for errors. You can significantly reduce the instances of such errors by validating your JavaScript code before deployment. *Linters* check basic syntax and provide warnings about style.

Formatters are tools that implicitly understand the syntactical rules of a language and use a collection of indentation, whitespace, line wrap, and other strategies to give you the capability to automatically

neatly organize the content of a file. Formatters will never break or modify the code or semantic meaning of the code, as they are aware of the kinds of modifications that would serve to alter the execution.

ESLint

ESLint is an open-source JavaScript linting utility originally developed by none other than the author of early editions of this very book, Nicholas Zakas. It is designed to be completely “pluggable”: It comes out of the box with a commonsense set of default rules, but the rules are totally configurable, and there is a large library of modifiable and toggle-able rules that can be used to adjust the linter’s behavior.

Website: www.eslint.org/

Google Closure Compiler

Built into the Closure Compiler is a linting utility that can be activated using command-line flags. This linter operates on the abstract syntax tree of your code, so it does not perform checks for whitespace, indentation, or other code organization matters that do not affect code execution.

Website: <https://developers.google.com/closure/>

JSLint

JSLint is a JavaScript validator written by Douglas Crockford. It checks for syntax errors at a core level, going with the lowest common denominator for cross-browser issues. (It follows the strictest rules to ensure your code works everywhere.) You can enable Crockford’s warnings about coding style, including code format, use of undeclared global variables, and more. Even though JSLint is written in JavaScript, it can be run on the command line through the Java-based Rhino interpreter, as well as through WScript and other JavaScript interpreters. The website provides custom versions for each command-line interpreter

Website: www.jshint.com/

JSHint

JSHint is a fork of JSLint that provides more customization as to the rules that are applied. Like JSLint, it checks for syntax errors first and then looks for problematic coding patterns. Each JSLint check is also present in JSHint, but developers have better control over which rules to apply. Also similar to JSLint, JSHint can be run on the command line using Rhino.

Website: www.jshint.com/

Clang Format

ClangFormat is a set of formatting tools built atop the LibFormat library, based on the Clang project. It uses Clang formatting rules to automatically spatially reorganize your code (without actually changing its semantic structure). It works as a standalone tool that can be used from the command line, but it also features multiple editor integrations.

Website: <https://clang.llvm.org/docs/ClangFormat.html>

MINIFIERS

An important part of the JavaScript build process is crunching the output to remove excess characters. Doing so ensures that only the smallest number of bytes are transmitted to the browser for parsing and ultimately speeds up the user experience. There are several such *minifiers* available with varying compression ratios.

Uglify

Uglify, currently in its third release, is a toolkit that allows you to minify, beautify, and compress your JavaScript code. It can be run on the command line, and it offers an extremely wide range of compression options that you can tweak to customize your minification.

Website: <https://github.com/mishoo/UglifyJS2/>

Google Closure Compiler

Although not strictly a minifier, Closure offers a number of optimization levels that will, as part of their optimization routines, minify your code.

Website: <https://developers.google.com/closure/>

JSMIn

JSMIn is a C-based cruncher written by Douglas Crockford that does basic JavaScript compression. It primarily removes white space and comments to ensure that the resulting code can still be executed without issues. JSMIn is available as a Windows executable with source code available in C and many other languages.

Website: www.crockford.com/javascript/jsmin.html

Dojo ShrinkSafe

The same people responsible for the Dojo Toolkit have a tool called *ShrinkSafe*, which uses the Rhino JavaScript interpreter to first parse JavaScript code into a token stream and then use that to safely crunch the code. As with JSMIn, ShrinkSafe removes extra white space (but not line breaks) and comments but also goes one step further and replaces the names of local variables with two-character variable names instead. The result is smaller output than with JSMIn without any risk of introducing syntax errors.

Website: <http://shrinksafe.dojotoolkit.org/>

UNIT TESTING

Most JavaScript libraries use some form of unit testing on their own code, and some publish the unit-testing framework for others to use. *Test-driven development (TDD)* is a software-development process built around the use of unit testing.

Mocha

One of the most popular unit test frameworks available, Mocha offers excellent configurability and extensibility when developing your unit tests. Tests are quite flexible, and their serial execution means accurate reporting and easier debugging.

Website: <https://mochajs.org/>

Jasmine

Although it is on the older side of the spectrum of unit test frameworks, Jasmine is still extremely popular. It comes with everything you need out of the box—meaning no external dependencies—and its syntax is simple and easy to read.

Website: <https://jasmine.github.io/>

qUnit

qUnit is the unit-testing framework designed for use with jQuery. Indeed, jQuery itself uses qUnit for all of its testing. Despite this, qUnit has no dependency on jQuery and can be used to test any JavaScript code. qUnit is known for being a very simple unit-testing framework that lets people get up and running easily.

Website: <https://github.com/jquery/qunit>

JsUnit

The original JavaScript unit-testing library is not tied to any particular JavaScript library. *JsUnit* is a port of the popular JUnit testing framework for Java. Tests are run in the page and may be set up for automatic testing and submission of results to a server. The website contains examples and basic documentation.

Website: www.jsunit.net/

Dojo Object Harness

The *Dojo Object Harness (DOH)* began as the internal unit-testing tool for Dojo before being released for everyone to use. As with the other frameworks, unit tests are run inside the browser.

Website: www.dojotoolkit.org/

DOCUMENTATION GENERATORS

Most IDEs include documentation generators for the primary language. Because JavaScript has no official IDE, documentation has traditionally been done by hand or through repurposing documentation generators for other languages. However, there are a number of documentation generators specifically targeted at JavaScript.

ESDoc

ESDoc is capable of generating very advanced documentation pages for your code, including the ability to feature links to source code from the documentation page itself. It also features a library of plugins to extend its features. However, ESDoc requires your codebase to consist exclusively of ES6 modules.

Website: <https://esdoc.org/>

documentation.js

documentation.js processes JSDoc comments inside your code to auto-generate documentation in HTML, Markdown, or JSON. It is compatible with the latest versions of ECMAScript and all major build tools, and also can work with Flow annotations.

Website: <https://documentation.js.org/>

Docco

Per the website, Docco is a “quick and dirty” documentation generator. The motivation behind the tool is that it is a very simple way of generating HTML pages which describe your codebase. Docco is brittle in a few ways, but it offers the fewest barriers to generating documentation from your code.

Website: <http://ashkenas.com/docco/>

JsDoc Toolkit

The *JsDoc Toolkit* was one of the first JavaScript documentation generators. It requires you to enter Javadoc-like comments into the source code, which are then processed and output as HTML files. You can customize the format of the HTML using one of the prebuilt JsDoc templates or you can create your own. The JsDoc Toolkit is available as a Java package.

Website: <https://github.com/jsdoc3/jsdoc/>

YUI Doc

YUI Doc is YUI’s documentation generator. The generator is written in Python, so it requires a Python runtime environment to be installed. YUI Doc outputs HTML files with integrated property and method searches implemented using the YUI’s Autocomplete widget. As with JsDoc, YUI Doc requires Javadoc-like comments to be inserted into the source code. The default HTML can be changed through the modification of the default HTML template file and associated style sheet.

Website: www.yuilib.com/projects/yuidoc/

AjaxDoc

The goal of *AjaxDoc* is slightly different from that of the previous generators. Instead of creating HTML files for JavaScript documentation, it creates XML files in the same format as those created for .NET languages, such as C# and Visual Basic .NET. Doing so allows standard .NET

documentation generators to create documentation as HTML files. AjaxDoc requires a format of documentation comments that is similar to the documentation comments for all .NET languages. AjaxDoc was created for use with ASP.NET Ajax solutions, but it can be used in standalone projects as well.

Website: www.codeplex.com/ajaxdoc/

INDEX

Symbols

- + (add) operator, 83–84
- & (AND) operator (bitwise), 74
- && (AND) operator (logical), 78–79
- * (asterisk), 26
- ` (backticks), 46, 47
- { } (curly braces), 27–28, 111
- \$ (dollar sign), 26
- / (divide) operator, 81
- ** (exponentiation operator), 82
- == (equal) operator, 86–87, 833–835
- / (forward slash), 26
- > (greater-than) operator, 85–86
- >= (greater-than-or-equal-to) operator, 85–86
- === (identically equal to) operator, 87–88
- << (left shift), 76
- < (less-than) operator, 19, 85–86
- <= (less-than-or-equal-to) operator, 85–86
- (minus signs), 69
- & (modulus) operator, 82
- * (multiply) operator, 80–81
- ! (NOT) operator, 73–74, 77–78
- != (not-equal) operator, 86–87, 833–835
- !== (not identically equal to) operator, 88
- | (OR) operator (bitwise), 74–75
- || (OR) operator (logical), 79–80
- ++ (plus signs), 68
- >> (signed right shift), 76
- + (single plus sign), 70–72
- (subtract) operator, 84–85
- _ (underscore), 26
- >>> (unsigned right shift), 76–77
- ^ (XOR) operator, 75

A

- abort() method, 767, 874
- aborting requests, 894–895
- absolute property, 649
- abstract base classes, 316–317
- acceleration property, 650

- accelerationIncludingGravity property, 650
- acceptCharset property, 707
- acceptNode() method, 587
- accessibility issues, 634
- accessing element styles, 572–576
- accessors
 - properties of, 254–255
 - prototype, 308–309
 - static class, 309–310
- action property, 708
- activate property, 1009
- activated state, 1023
- activating state, 1022–1023
- activation object, 107
- active property, 1007
- activeVrDisplays property, 454
- add() method, 110, 212–213, 218, 219, 549, 726, 730, 935, 936, 1015
- add (+) operator, 83–84
- addAll() method, 1015
- addElement() method, 774
- addEventListener() method, 607–608, 611–615
- addHandler() method, 610–611
- adding
 - options, 730
 - web component content, 804–805
- additive operators, 82–85
- addRange() method, 739
- addSomeNumber() function, 356
- addTen() function, 104
- advance() method, 938, 940
- Advanced Encryption Standard (AES), 813
- AES-CBC, 813
- AES-CTR, 813
- AES-GCM, 814
- AES-KW, 814
- AjaxDoc, 1111–1112
- alert() method, 448
- algorithms
 - CryptoKey class and, 812–814
 - structured clone, 987–988
- almost standards mode, 22–23

- alpha property, 649, 693
- anchor() method, 157
- anchorNode property, 738
- anchorOffset property, 738
- AND argument, 1091–1092
- AND (&) operator (bitwise), 74
- AND (&&) operator (logical), 78–79
- Android, 478
- Angular framework, 1096
- animation, 1099. *See also* <canvas> element
- anonymous functions. *See* closures
- anotherFactorial() function, 372
- anotherSum() function, 352
- antialias property, 693
- APIs. *See specific APIs*
- appName property, 454
- append() method, 878, 896
- appendChild() method, 495–496, 497, 499, 513, 519–520, 595, 731, 1057
- application logic, decoupling, 1041–1042
- apply() method, 295, 368–369
- apply() trap, 342–343
- appName property, 454
- appVersion property, 455
- arguments
 - about, 353–355
 - passing, 103–105, 295
 - spread, 359–360
- arguments object, 364
- arithmetic methods, 745–747
- array flattening methods, 1082–1084
- array holes, 172–174
- array literal notation, 171
- Array property, 160
- Array type
 - about, 170
 - array holes, 172–174
 - conversion methods, 179–180
 - copy and fill methods, 176–178
 - creating arrays, 170–172
 - detecting arrays, 175
 - indexing into arrays, 174–175
 - iterative methods, 188–189
 - iterator methods, 176
 - manipulation methods, 184–186
 - queue methods, 181–182
 - reduction methods, 189–190
 - reordering methods, 182–184
 - search and location methods, 186–188
 - stack methods, 180–181
- ArrayBuffers, 191–192
- Array.from() method, 171–172, 221–222
- Array.isArray() method, 175
- Array.of() method, 221–222
- Array.prototype.flat() method, 1083
- Array.prototype.flatMap() method, 1084
- Array.prototype.flatten() method, 1082–1084
- arrays. *See also* typed arrays
 - creating, 170–172
 - detecting, 175
 - indexing into, 174–175
 - JSON, 863–864
 - using, 1055–1056
- arrow functions, 350–351, 355
- asm.js, 1105
- assert() function, 844
- assign() method, 452–453
- assignHandler() function, 381
- assignment operators, 88–89
- asterisk (*), 26
- astral plane, 145
- asymmetric keys, signing and verifying messages
 - with, 819–820
- async attribute, 13, 16, 17–18, 422–424
- async callbacks, 540–541
- async functions
 - about, 421
 - basics of, 422–427
 - halting, 427–430
 - resuming, 427–430
 - strategies for, 430–435
- async iterator
 - creating, 1068–1070
 - implementing observables, 1073–1076
 - queue, 1070–1072
 - reject() handling, 1072
 - top-level Async loops, 1073
 - using next(), 1072–1073
- async loops, 1073
- asynchronous programming
 - about, 392
 - dependencies, 948
 - legacy patterns, 393–395
 - modules, 956
 - nesting callbacks, 394–395
 - scripts, 17–18
 - synchronous *versus*, 392–393
 - tasks, 411
- atob() method, 972
- Atomics API
 - about, 744, 1106
 - basics of, 745–751
 - reads, 747–748
 - writes, 747–748

attachEvent() method, 608–610, 615
 Attr type, 520–521
 attributeFilter property, 534
 attributeOldValue property, 535
 attributes
 custom data, 551–552
 custom element, 806–807
 defined, 698
 getting, 510–511
 observing mutations of, 535–536
 property, 256–257
 setting, 511
 attributes property, 511–513, 534
 Audio type, 770
 automatic tab forward, 721–723
 automation systems, 1107
 autoplay property, 765
 availHeight property, 459
 availLeft property, 459
 availTop property, 460
 availWidth property, 460
 await keyword, 424–427

B

Babel, 1104
 back() method, 461
 Backbone.js framework, 1097
 back-forward cache, 645
 background scripts, 973
 backpressure, 778–779
 backticks (`), 46, 47
 backwards compatibility, 966
 Basic Multilingual Plane (BML), 145
 battery property, 455
 Battery Status API, 487–488
 Beacon API, 914–915
 beforeunload event, 643
 begin() method, 931
 behaviors, for typed arrays, 197–198
 best practices
 about, 1036
 deployment, 1059–1064
 maintainability, 1035–1047
 performance, 1047–1059
 beta property, 649
 big() method, 157
 bind() method, 352, 369
 bitwise methods, 745–747
 bitwise operators, 72–77
 Blob(s)

 about, 758–764
 loading files as, 894
 Object URLs and, 762–763
 partial reads and, 761–762
 block body, 351
 block comment, 26
 blocking characters, 719–720
 blue event, 624
 blur() method, 713–714
 <body> element, 16, 526
 Body.arrayBuffer() method, 907–908
 Body.blob() method, 908
 Body.formData() method, 907
 Body.json() method, 906–907
 Body.text() method, 906
 bold() method, 157
 BOM (Browser Object Model)
 about, 10–11, 437
 history object, 460–462
 location object, 450–454
 navigator object, 454–459
 objects in, 68, 116
 screen object, 459–460
 window object, 438–450
 Boolean() function, 78
 Boolean operators, 77–80
 Boolean type, 40, 141, 160
 bound() method, 939–940
 Bower, 1102
 Bowser (website), 480
 bracket notation, 168
 Brackets, 1106
 break statement, 94–95
 BroadcastChannel, 986–987
 Browser Object Model (BOM)
 about, 10–11, 437
 history object, 460–462
 location object, 450–454
 navigator object, 454–459
 objects in, 68, 116
 screen object, 459–460
 window object, 438–450
 Browserify, 1103
 browsers. *See also specific browsers*
 analysis, using capability detection for, 468–470
 analysis, using user-agent detection for, 478–480
 current-device, 480
 error reporting, 824
 Google Chrome, 480
 identifying, 481–482
 metadata, 482–488
 Mootools, 480

- support for Document Object Model (DOM)
 - in, 9–10
- support for ECMAScript in, 5–7
- XML DOM support in, 849–852
- XPath support in, 852–857
- XSLT support in, 857–859
- Brunch, 1107
- `btoa()` method, 972
- bubbles property, 612
- buffered property, 765
- bufferedBytes property, 765
- bufferingRate property, 765
- bufferingThrottled property, 765
- buffers, WebGL, 696–697
- build tools, 1107
- buildID property, 455
- `buildUrl()` function, 109
- bulk decoding, 755–756
- bulk encoding, 753–754
- buttons, 631–632
- Bynen, Mathias (blogger), 144

C

- cache, service workers, 1012–1017
- Cache object, 1014–1017
- cacheName property, 1016
- caches property, 972, 1008
- CacheStorage object, 1013–1014
- caching external files and, 21
- `call()` method, 295, 368–369
- callbacks, 530–532
- caller object, 366–367
- `callSomeFunction()` function, 362–363
- `callSum()` method, 368–369
- cancelable property, 612
- `cancelAnimationFrame`, 674
- `cancelBubble` property, 615
- canplay event, 767
- canplaythrough event, 767
- `canPlayType()` method, 769
- `canshowcurrentframe` event, 767
- `<canvas>` element
 - about, 671
 - basic use of, 676–677
 - 2D, 677–692
 - using `requestAnimationFrame`, 672–675
 - WebGL, 692–705
- capability detection
 - about, 466–467

- safety and, 467
 - using for browser analysis, 468–470
- case-sensitivity, 26
- casting, with `Promise.resolve()` method, 398–399
- `catch()` method, 407, 410–411, 412
- catch statement, 109
- CDATASection type, 518
- `changeColor()` function, 107–108
- character codes, 636–637
- character data, observing mutations of, 536–537
- character literals, 47–48
- character set properties, 551
- `characterData` property, 535
- `characterDataOldValue` property, 535
- characters, blocking, 719–720
- `charAt()` method, 144, 146
- `charCodeAt()` method, 145
- charging property, 487
- `chargingTime` property, 488
- charset attribute, 13
- checking validity, 725–726
- `checkValidity()` method, 725–726
- `childElementCount` property, 546
- `childList` property, 535
- `childNodes` property, 495
- children
 - Element type, 513–514
 - observing mutations, 537–539
- children property, 557
- chunks, 778–779
- circular dependencies, 949–950
- circular reference, 115
- `claim()` method, 1018
- Clang Format, 1108
- classes
 - about, 302
 - abstract base, 316–317
 - constructor keyword, 303–307
 - definition basics, 302–303
 - hidden, 118–119
 - inheritance, 312–320
 - instance members, 307–308
 - iterator and generator methods, 311–312
 - non-function prototype and class members, 310
 - prototype methods and accessors, 308–309
 - as special functions, 306–307
 - static methods and accessors, 309–310
 - strict mode, 1093
- `classList` property, 548–549
- class-related additions, 547–549
- `clear()` method, 201–202, 929, 932, 935

- clearData() method, 720–721, 774
- clearInterval() method, 447, 972
- clearRect() method, 677–679
- clearTimeout() method, 446–447, 972
- click event, 625
- client coordinates, 627
- client detection
 - about, 465
 - capability detection, 466–470
 - hardware detection, 480–489
 - software detection, 480–489
 - user-agent detection, 470–480
- client domensions, 581–582
- clients, service worker, 1017–1018
- clients property, 1008
- client-side storage
 - about, 919
 - cookies, 919–929
 - IndexedDB, 933–943
 - Web Storage, 929–933
- Clipboard, 720–721
- clone() method, 898–900, 905
- cloneContents() method, 595
- cloneNode() method, 497, 571
- cloneRange() method, 598
- cloning
 - DOM ranges, 598
 - Request objects, 898–900
 - Response objects, 905
- close() method, 444, 504–506, 776, 976, 977, 978, 1000
- closePath() method, 680
- closures
 - about, 370, 376–379
 - memory leaks, 381–382
 - this object, 379–381
- code
 - consistency in, 1018
 - conventions for, 1036–1039
 - maintainable, 1036
 - minification, 1062–1064
- code point, 146
- code size, 1062
- codec support detection, 769
- codePointAt() method, 146
- CoffeeScript, 1104
- collapse() method, 597, 739
- collapseToEnd() method, 739
- collapseToStart() method, 739
- collection reference types
 - Array type, 170–190
 - iteration, 220–222
 - Map type, 201–206
 - Object type, 164–170
 - Set type, 211–217
 - spread operators, 220–222
 - typed arrays, 190–200
 - WeakMap type, 206–211
 - WeakSet type, 217–220
- colorDepth property, 460, 482
- combination inheritance, 296–297
- comma operators, 89
- commands, for rich text, 735–738
- Comment type, 517–518
- comments, 26
- commit() method, 931
- commonAncestorContainer property, 591
- CommonJS, 953–956
- communicating
 - with dedicated workers, 983–987
 - errors in, 837–838
- compare() function, 377
- compareBoundaryPoints() method, 598
- compassCalibrated property, 649
- compatibility mode, 550–551
- compilation, 1063, 1104–1105
- compositing, 691–692, 799–801
- composition events, 640–641
- compositionend event, 640
- compositionstart event, 640
- compositionupdate event, 640
- compound-assignment operators, 89
- compression, 1062–1064
- computed styles, 575–576
- concat() method, 148, 149, 184–186, 198–200
- concurrency issues, 943
- conditional declarations, 32–33
- conditional operators, 88
- configuring worker options, 979
- confirm() method, 448–449
- connection property, 455
- connection state, 486–487
- consistency, service worker and, 1018–1019
- console property, 972
- console runtime, 841
- const declaration, 34–35, 36, 112–113, 118
- constants
 - using, 1046–1047
 - WebGL, 694
- construct() trap, 343–344
- constructor property
 - about, 67, 303–304

- classes as special functions, 306–307
- instantiation, 304–306
- constructor stealing, 294–296
- constructors
 - defined, 126
 - as functions, 272
 - problems with, 272–273
 - properties of, 137–139
 - validating parameters of, 346
- `contains()` method, 549, 557–558
- `containsNode()` method, 739
- `contenteditable`, 734–735
- context, 106–108
- contextmenu event, 641–642
- `continue()` method, 938, 940
- continue statement, 94–95
- controller property, 1006
- controlling
 - memory, 117–122
 - observer scope with `MutationObserverInit`, 534–540
 - state with executor, 397–398
- `controls` property, 765
- conversion methods, 179–180
- converting
 - numbers, 44–46
 - to strings, 48–49
- `cookieEnabled` property, 455
- cookies
 - about, 919–920
 - components of, 921–922
 - considerations for, 928–929
 - JavaScript, 922–924
 - restrictions, 920–921
 - subcookies, 925–928
- `CookieUtil.get()` method, 923
- `CookieUtil.set()` method, 924, 927
- `CookieUtil.unset()` method, 928
- coordinates, WebGL, 695–696
- copy and fill methods, 176–178
- copying
 - typed arrays, 198–200
 - values, 103
- `copyWithin()` method, 176–178
- `createAnother()` function, 299
- `createAttribute()` method, 521
- `createAttributeNS()` method, 567
- `createComparisonFunction()` method, 372, 377–378
- `createDocument()` method, 570, 850
- `createDocumentType()` method, 570
- `createElement()` method, 513, 1057–1058
- `createElementNS()` method, 567
- `createEventObject()` method, 668–669
- `createExpression()` method, 852
- `createImageBitmap()` method, 972
- `createIndex()` method, 941–943
- `createLinearGradient()` method, 687–688
- `createNSResolver()` method, 852
- `createPattern()` method, 689
- `createPerson()` function, 118, 269, 270
- `createRectLinearGradient()` method, 688
- `createTextRange()` method, 718
- creating
 - arrays, 170–172
 - Async iterator, 1068–1070
 - cryptographic digests, 810–812
 - `CryptoKey` class, 814–816
 - dedicated workers, 973–974
 - elements, 513
 - passthrough proxies, 324–325
 - Request objects, 897–898
 - Response objects, 901–903
 - rules, 578–579
 - service workers, 1004–1005
 - shader programs, 698–699
 - shadow DOM, 796–797
 - shared workers, 997–998
 - text nodes, 515–516
 - workers from inline JavaScript, 979–980
- credentialed requests, 883–884
- `credentials` property, 455, 979
- Crockford, Douglas, 297, 387, 861
- cross-browser event handlers, 610–611
- cross-browser event object, 617–618
- cross-context messaging, 751–753
- cross-document messaging (XDM), 751
- cross-domain techniques, 884–885
- `crossorigin` attribute, 13
- cross-origin requests, sending, 894
- Cross-Origin Resource Sharing (CORS), 703, 881–884
- cross-site request forgery (CSRF) attack, 917
- cross-site scripting, considerations for, 556
- cryptographically secure pseudorandom number generator (CSPRNG), 809
- `CryptoKey` class, 812–814, 814–816
- CSS rules, 577–578
- CSS/JavaScript, decoupling, 1041
- `cssRules` property, 577
- `cssText` property, 573, 577
- curly braces (`{}`), 27–28, 111
- current-device (website), 480
- `currentLoop` property, 765
- `currentSrc` property, 765
- `currentTarget` property, 612

currentTime property, 765
 cursors
 querying with, 937–939
 setting direction, 940
 custom data attributes, 551–552
 custom DOM events, 667–668
 custom element lifecycle hooks, 805–806
 custom media players, 768–769
 CustomElementRegistry.get() method, 807–808
 CustomElementRegistry.whenDefined() method, 807–808
 customError property, 725

D

D3, 1099
 data
 consistency in, 1019
 receiving, 916
 sending, 916
 data binding, 347
 data properties, 252–254
 data types
 about, 36
 Boolean, 40
 errors, 835–837
 Null, 39
 Number, 41–46
 Object, 67–68
 String, 46–53
 Symbol, 54–67
 typeof operator, 36–37
 Undefined, 37–38
 databases, IndexedDB, 933–934
 dataTransfer object, 772–773
 dataunavailable event, 767
 DataViews, 192–195
 Date property, 160
 Date type
 about, 126–128
 date-formatting methods, 129
 date/time component methods, 129–131
 inherited methods, 128
 date-formatting methods, 129
 Date.now() method, 128, 786–787
 Date.parse() method, 126–127
 date/time component methods, 129–131
 Date.UTC() method, 126, 127
 dblclick event, 625
 debugging
 about, 823, 840
 browser error reporting, 824
 common legacy Internet Explorer errors, 844–846
 console runtime, 841
 JavaScript Debugger, 842
 logging messages to console, 840–841
 logging messages to pages, 842–843
 programs, 700–701
 shaders, 700–701
 shimming console methods, 843
 throwing errors, 843–844
 declarations
 conditional, 32–33
 const, 34–35
 function expressions *versus* function, 361–362
 global, 32
 styles, 35–36
 decode() method, 756
 decodeURI() method, 158–159
 decodeURIComponent() method, 158–159, 451–452
 decoding
 stream, 756–758
 text, 755–758
 decoupling
 application logic, 1041–1042
 CSS/JavaScript, 1041
 event handlers, 1041–1042
 HTML/JavaScript, 1039–1041
 decrement operator, 68–70
 decrypting symmetric keys, 820
 dedicated workers
 about, 971, 973–976
 communicating with, 983–987
 configuring options, 979
 creating, 973–974
 creating from inline JavaScript, 979–980
 delegating tasks to subworkers, 982
 dynamic script execution inside, 980–982
 handling errors, 983
 implicit MessagePorts and, 976–977
 lifecycle, 977–979
 security restrictions, 974–975
 worker data transfer, 987–993
 worker pools, 993–997
 DedicatedWorkerGlobalScope, 976
 default export, 961
 default parameter values, 356–358
 default type results, 855–856
 defaultPlaybackRate property, 765
 defaultPrevented property, 612
 defer attribute, 14, 16, 17
 deferred scripts, 17
 define() method, 803

- defineProperty() trap, 336–337
- delegating
 - events, 659–661
 - tasks to subworkers, 982
- delete() method, 201–202, 207–209, 213, 895–897, 935, 938, 1013–1014, 1015
- delete operation, 118–119
- deleteContents() method, 594–595
- deleteFromDocument() method, 739
- deleteItem() method, 932
- deleteProperty() trap, 338–339
- deleteRule() method, 577, 579
- deleting rules, 579
- dependencies
 - asynchronous, 948
 - circular, 949–950
 - module, 946
 - programmatically, 948
- deployment
 - about, 1059
 - build process, 1059–1061
 - compression, 1062–1064
 - validation, 1061–1062
- deprecated syntax, 20–21
- depth property, 693
- dereferencing values, 117–118
- deriveBits() method, 817–818
- deriveKey() method, 817–818
- desktop consoles, 824
- destructuring, 152–153
- detach() method, 598–599
- detachEvent() method, 608–610
- detail property, 612
- detecting
 - arrays, 175
 - elements, 500–502
 - plug-ins, 456–459
- deviceMemory property, 455
- devicemotion event, 650
- deviceorientation event, 648–650
- devices
 - events, 647–650
 - keyboard events on, 639–640
 - memory, 489
- diff() function, 99
- disabled property, 576, 711
- disabling validation, 726
- dischargingTime property, 488
- disconnect() method, 532, 533, 541
- dispatchEvent() method, 666
- dispatching requests, 886
- displayInfo() function, 169
- displaying notifications, 775–776, 1030–1031
- <div> element, 528
- divide (/) operator, 81
- doAdd() function, 354
- Docco, 1111
- document children, 498–499
- document modes, 22–23
- Document Object Model (DOM)
 - about, 7–8, 9, 491, 563–564
 - changes in, 564–571
 - dynamic scripts, 521–523
 - dynamic styles, 523–525
 - Element Traversal API, 546–557
 - event flow, 603–604
 - event object, 611–615
 - event simulation, 663–668
 - events, 9
 - extensions, 543–560
 - hierarchy of nodes, 492–521
 - levels, 8–9, 637–638, 850, 852–854
 - manipulating tables, 525–527
 - methods, 573–574
 - MutationObserver API, 529–542
 - necessity of, 8
 - node metadata, 211
 - NodeList object, 528–529
 - objects in, 68, 116
 - optimizing interactions, 1056–1059
 - properties, 573–574
 - proprietary extensions, 557–560
 - ranges, 9, 590–599
 - Selectors API, 544–545
 - shadow, 795–802
 - styles, 9, 572–584
 - support for in web browsers, 9–10
 - traversals, 9, 584–590
 - views, 8
 - working with, 521–529
 - XML namespaces, 564–568
 - XML support in browsers, 849–852
- Document type
 - about, 498
 - changes to, 568–569
 - document children, 498–499
 - document information, 499–500
 - document writing, 504–506
 - DOM conformance detection, 503–504
 - locating elements, 500–502
 - special collections, 502–503
 - document writing, 504–506
- documentation generators, 1110–1112
- documentation.js, 1111

- document.createAttribute() method, 521
- document.createDocumentFragment() method, 519–520
- document.createElement() method, 513, 791–792
- document.createTextNode() method, 515–516
- document.createTreeWalker() method, 588
- document.execCommand() method, 737
- DocumentFragment, 792–793
- DocumentFragment type, 519–520
- document.getElementById() method, 466
- document.querySelector() method, 792–793
- documents changes, 567, 569–570
- DocumentType type, 518–519
- Dojo Object Harness, 1110
- Dojo ShrinkSafe, 1109
- The Dojo Toolkit library, 1098
- dollar sign (\$), 26
- DOM. *See* Document Object Model (DOM)
- DOM (Document Object Model)
 - about, 7–8, 9, 491, 563–564
 - changes in, 564–571
 - dynamic scripts, 521–523
 - dynamic styles, 523–525
 - Element Traversal API, 546–557
 - event flow, 603–604
 - event object, 611–615
 - event simulation, 663–668
 - events, 9
 - extensions, 543–560
 - hierarchy of nodes, 492–521
 - levels, 8–9, 637–638, 850, 852–854
 - manipulating tables, 525–527
 - methods, 573–574
 - MutationObserver API, 529–542
 - necessity of, 8
 - node metadata, 211
 - NodeList object, 528–529
 - objects in, 68, 116
 - optimizing interactions, 1056–1059
 - properties, 573–574
 - proprietary extensions, 557–560
 - ranges, 9, 590–599
 - Selectors API, 544–545
 - shadow, 795–802
 - styles, 9, 572–584
 - support for in web browsers, 9–10
 - traversals, 9, 584–590
 - views, 8
 - working with, 521–529
 - XML namespaces, 564–568
 - XML support in browsers, 849–852
- domain property, 932
- DOMContentLoaded event, 643–644
- DOMFocusIn event, 624
- DOMFocusOut event, 624
- DOMParser type, 850–851
- doNotTrack property, 455
- dot notation, 168
- dotAll, 1080
- double interpretation, avoiding, 1053–1054
- double-byte characters, 48
- Douglas Crockford's JSLint*, 1061
- do-while statement, 90–91
- downlink property, 486
- downlinkMax property, 486
- drag and drop
 - about, 770
 - additional members, 774–775
 - custom drop targets, 771–772
 - dataTransfer object, 772–773
 - draggability, 774
 - dropEffect property, 773–774
 - effectAllowed property, 773–774
 - events, 770–771
 - file reading, 763–764
- drawImage() method, 686
- drawing
 - images, 686–687
 - paths, 679–681
 - rectangles, 677–679
 - text, 681–683
 - in WebGL, 695, 701–703
- dropEffect property, 773–774
- duration property, 765
- durationchange event, 767
- dynamic properties, 102–103
- dynamic scripts, 18, 521–523, 980–982
- dynamic styles, 523–525

E

- each() method, 1043–1044
- ECMA-262, 3, 4–5
- ECMAScript
 - about, 3
 - conformance, 5
 - editions, 4–5
 - reference types (*See* reference types)
 - support for in web browsers, 5–7
- editions, ECMAScript, 4–5
- editors, 1106
- effectAllowed property, 773–774

- effectiveType property, 486–487
- effects, 1099
- Eich, Brendan (developer), 2
- element dimensions, 579–584
- Element Traversal API
 - about, 546–547
 - changes to HTMLDocument type, 550–551
 - character set properties, 551
 - classList property, 548–549
 - class-related additions, 547–549
 - custom data attributes, 551–552
 - focus management, 549–550
 - HTML5, 547
 - markup insertion, 552–556
 - scrollIntoView() method, 556–557
- Element type
 - about, 506–507
 - attributes property, 511–513
 - children, 513–514
 - creating elements, 513
 - getting attributes, 510–511
 - HTML elements, 507–509
 - setting attributes, 511
- elements
 - accessing styles, 572–576
 - changes to, 567–568
 - creating, 513
 - custom, 802–808
 - determining dimensions, 584
 - locating, 500–502
- elements property, 708
- Elliptic Curve Diffie-Hellman (ECDH), 813
- Elliptic Curve Digital Signature Algorithm (ECDSA), 813
- Elliptic-Curve Cryptography (ECC), 813
- Ember framework, 1096
- emptied event, 767
- empty event, 767
- Emscripten, 1105
- enableHighAccuracy property, 485
- encode() method, 754
- encodeInto() method, 754
- encodeURIComponent() method, 158–159
- encodeURIComponent() method, 158–159, 837
- encoding
 - stream, 754–755
 - text, 753–755
- Encoding API, 753–758
- encrypting symmetric keys, 820
- enctype property, 708
- endContainer property, 590
- ended event, 767
- ended property, 765
- endianness, 194
- endOffset property, 591
- endsWith() method, 151
- entries() method, 214
- entry points, for modules, 947
- enumeration order, 283–284
- equal (==) operator, 86–87, 833–835
- equality operators, 86–88
- error event, 767, 831–832
- error handling
 - about, 823, 825
 - browser error reporting, 824
 - common legacy Internet Explorer errors, 844–846
 - error event, 831–832
 - fatal errors, 838–839
 - identifying location of errors, 833–838
 - log errors, 839–840
 - nonfatal errors, 838–839
 - rejection, 408–410
 - strategies for, 832
 - try-catch statement, 825–829
- error() method, 840
- Error type, 160, 827
- errors
 - communication, 837–838
 - data types, 835–837
 - fatal, 838–839
 - handling, 983
 - nonfatal, 838–839
 - throwing, 829–831, 843–844
 - type coercion, 833–835
 - types of, 826–827
 - WebGL, 697
- ES6 modules, 958–966
- ES2018/ES2019
 - about, 1068–1069
 - array flattening methods, 1082–1084
 - asynchronous iteration, 1068–1076
 - creating Async iterator, 1068–1070
 - finally() handler, 1078–1079
 - miscellaneous enhancements, 1086
 - Object.fromEntries(), 1084–1085
 - optional catch binding, 1086
 - regular expression enhancements, 1079–1082
 - rest operator, 1076–1077
 - spread operator, 1077–1078
 - string trimming methods, 1085
 - Symbol.prototype.description, 1085
- ESDoc, 1111
- ESLint, 1061, 1108

- eval() function, 108, 159–160, 828, 865, 1053–1054, 1091
- EvalError property, 160
- EvalError type, 827
- evaluate() method, 852, 853, 854, 856–857
- event bubbling, 602
- event capturing, 603
- event delegation, 1058
- event handlers
 - about, 604
 - cross-browser, 610–611
 - decoupling, 1041–1042
 - DOM level 0, 606–607
 - DOM level 2, 607–608
 - HTML, 604–606
 - Internet Explorer, 608–610
 - removing, 661–662
- event object
 - about, 611
 - cross-browser, 617–618
 - DOM, 611–615
 - Internet Explorer, 615–617
- eventPhase property, 612
- event.preventDefault() method, 641–642
- events
 - about, 601, 619
 - composition, 640–641
 - custom DOM, 667–668
 - delegating, 659–661
 - device, 647–650
 - drag and drop, 770–771
 - event handlers, 604–611
 - event object, 611–618
 - flow of, 602–604, 603–604
 - focus, 624–625
 - form field, 714–715
 - gesture, 653–654
 - HTML5, 641–647
 - keyboard, 634–640, 664–667
 - media elements, 767–768
 - memory and, 659–662
 - mouse, 625–634, 663–664
 - mutation, 641
 - performance and, 659–662
 - progress, 880–881
 - references, 654–659
 - retargeting, 801–802
 - simulating, 662–669
 - simulating in Internet Explorer, 668–669
 - text, 634–640
 - touch, 651–653
 - types, 619–659

- UI, 619–624
- Web Sockets, 916–917
- wheel, 625–634
- EventUtil.getEvent() method, 618
- every() method, 188–189
- exchange() method, 748–749
- exchanges, 748–749
- exec() method, 135–136, 137–138, 153
- execution context. *See* context
- exponentiation operator (**), 82
- exporting keys, 816–817
- exportKey() method, 816
- expression context, 168
- expressions, function, 370–372
- extend() method, 739
- ExtendableEvent.waitUntil() method, 1021
- Extensible HyperText Markup Language (XHTML), 19–20
- extensions
 - Document Object Model (DOM), 543–560
 - promises, 418–421
- external files, inline code *versus*, 21–22
- extractContents() method, 595

F

- factorial() function, 364, 372
- factory pattern, 269
- failures, handling, 394
- fast user-space mutex, 749
- fatal errors, 838–839
- “Feature Detection: State of the Art Browser Scripting” (Michaux), 467
- Fetch API
 - about, 777, 885, 1009
 - basic utilization of, 886–892
 - common fetch patterns, 893–895
 - Headers object, 895–897
 - Request object, 897–900
 - requests, 906–914
 - Response object, 901–905
 - responses, 906–914
- fetch() method, 886, 887–888, 888–892, 893–894, 894–895, 898, 900, 972, 1009, 1028–1030
- File API
 - drag-and-drop file reading, 763–764
 - File type, 758–759
 - FileReader type, 759–761
 - FileReaderSync type, 761
 - partial reads, 761–762
- file structure, 1060

- File type, 758–759
- FileReader type, 759–761
- FileReaderSync type, 761
- files
 - loading as Blobs, 894
 - sending, 893–894
- fill() method, 176–178
- fillRect() method, 677–679
- fills, 677
- fillText() method, 681–683
- filter() method, 188–189
- filtering results, 866–867
- finally() method, 407, 410–411, 412, 826, 1078–1079
- find() method, 187–188
- findIndex() method, 187–188
- Firebig Lite, 824
- firstChild() method, 588
- firstElementChild property, 546
- first-in-first-out (FIFO) structure, 181
- fixed() method, 157
- flags property, 134
- floating-point values, 41–42
- Flow, 1105
- focus events, 624–625
- focus management, 549–550
- focus() method, 549–550, 713–714
- focusin event, 624
- focusNode property, 738
- focusOffset property, 738
- focusout event, 624
- font property, 681
- fontcolor() method, 157
- fontSize() method, 157
- foo() function, 786–787
- for loops, 34
- for statement, 91–92
- for-await-of loop, 58–59, 1073
- forEach() method, 188–189
- for-in statement, 92–93
- form property, 711
- formatters, 1107–1108
- FormData type, 878–879
- forms
 - about, 707
 - basics of, 707–715
 - fields in, 710–715
 - resetting, 709–710
 - rich text editing, 734–740
 - scripting select boxes, 726–731
 - scripting text boxes, 715–726
 - serialization, 732–733
 - submitting, 708–709
- for-of statement, 93
- forward() method, 461
- forward slash (/), 26
- fragment shaders, 697
- frameworks
 - about, 1095
 - Angular, 1096
 - Backbone.js, 1097
 - Ember, 1096
 - Meteor, 1096
 - React, 1095–1096
 - Vue, 1096
- Friedman, Daniel
 - The Impact of Applicative Programming on Multiprocessing*, 395
- from() method, 171
- fromCharCode() method, 145, 146
- fulfilled state, 396, 397
- function constructor pattern, 269–273
- function declaration hoisting, 361, 370–371
- function expressions
 - about, 370–372
 - function arguments *versus*, 361–362
 - immediately invoked function expression (IIFE), 382–384
- Function property, 160
- functions, *See also specific functions*
 - about, 98–100, 349–350
 - arguments, 353–355
 - arrow, 350–351, 355
 - async, 421–435
 - classes as special, 306–307
 - closures, 376–382
 - composition of, 416–417
 - constructors as, 272
 - declarations *versus* expressions, 361–362
 - declarations *versus* function expressions, 361–362
 - default parameter values, 356–358
 - immediately invoked expression (IIFE), 382–384
 - immediately invoked function expression (IIFE), 382–384
 - internals, 364–367
 - lambda, 370
 - language, 98–100
 - methods, 367–370
 - names for, 351–352
 - names of, 351–352
 - naming, 1037–1038
 - overloading, 355–356
 - parameters, 1090–1091
 - private variables, 384–389

- properties, 367–370
- properties and methods, 367–370
- recursion, 372–373
- recursive, 372–373
- replacer, 869
- rest parameters, 360–361
- reviver, 869
- spread arguments, 359–360
- strict mode, 1089–1092
- tag, 51–53
- tail call optimization, 373–376
- validating parameters of, 346
- as values, 362–363

Futex operations and locks, 749–751

future-proof, external files and, 21

G

- gamma property, 649
- garbage collection
 - about, 114
 - managing memory, 117–122
 - mark-and-sweep, 115
 - MutationObserver, 541–542
 - performance, 116–117
 - reference counting, 115–116
- Garrett, Jesse James, 871
- Gecko, 473–475
- `generateKey()` method, 816
- generating
 - arrays, 170–172
 - Async iterator, 1068–1070
 - cryptographic digests, 810–812
 - `CryptoKey` class, 814–816
 - dedicated workers, 973–974
 - elements, 513
 - passthrough proxies, 324–325
 - Request objects, 897–898
 - Response objects, 901–903
 - rules, 578–579
 - service workers, 1004–1005
 - shader programs, 698–699
 - shadow DOM, 796–797
 - shared workers, 997–998
 - text nodes, 515–516
 - workers from inline JavaScript, 979–980
- generator methods, 311–312
- generator object, 236–237
- generators
 - about, 236–238
 - early termination of, 247–249
 - interrupting execution with `yield`, 238–246
 - using as default, 246–247
 - using as the default iterator, 246–247
- Geolocation API, 483–485
- geolocation property, 455
- gesture events, 653–654
- `get()` method, 201–202, 207–209, 325–326, 326–328, 895–897, 926, 935, 942–943
- GET requests, 876–877
- `get()` trap, 333–334
- `getAll()` method, 926, 927
- `getAllResponseHeaders()` method, 876
- `getAttribute()` method, 510–511, 512, 520–521
- `getAttributeNode()` method, 521
- `getAttributeNS()` method, 567
- `getClipboardText()` function, 721
- `getColor()` function, 113–114
- `getComputedStyle()` method, 575
- `getContext()` method, 676
- `getCurrentPosition()` method, 483, 484
- `getData()` method, 720–721, 772–773
- `getElement()` function, 466
- `getElementById()` method, 708
- `getElementsByClassName()` method, 547–548, 1043–1044
- `getElementsById()` method, 500
- `getElementsByName()` method, 502
- `getElementsByTagName()` method, 500–501, 514
- `getElementsByTagNameNS()` method, 567
- `getEvent()` method, 617–618
- `getIdentityFunc()` method, 380–381
- `getImageData()` method, 689
- `getItem()` method, 929
- `getKey()` method, 942–943
- `getModifierState()` method, 638
- `getName()` method, 386
- `getNamedItemNS()` method, 568
- `getNameFunc()` method, 380
- `getNotifications()` method, 1007
- `getOwnPropertyDescriptor()` trap, 337–338
- `getParameter()` method, 858–859
- `getPropertyCSSValue()` method, 573, 574
- `getPropertyPriority()` method, 573
- `getPropertyValue()` method, 573, 574
- `getPrototypeOf()` trap, 339–340
- `getRangeAt()` method, 739
- `getReader()` method, 780, 910
- `getRegistration()` method, 1006
- `getResponseHeader()` method, 876
- `getSelectedOptions()` function, 729
- `getSelection()` method, 738, 740
- `getSubValue()` method, 293

getSuperValue() method, 293
 getTarget() method, 618
 getUserMedia() method, 455
 getVRDisplays() method, 455
 getWindowWidth() function, 466
 getWriter() method, 781
 GitHub repository, 1068
 gl.createShader() method, 699
 gl.createTexture() method, 703
 gl.drawArrays() method, 702–703
 gl.getProgramParameter() method, 700
 gl.getShaderParameter() method, 700
 gl.getUniformLocation() method, 700
 global declarations, 32
 global lookups, avoiding, 1047–1048
 Global object
 about, 157
 eval() method, 159–160
 properties, 160
 URI-encoding methods, 158–159
 window object, 160
 global property, 134
 global variables, avoiding, 1044–1045
 gl.pixelStorei() method, 703
 gl.useProgram() method, 699
 Gmail, 838
 go() method, 460–461
 Google Chrome
 about, 476
 error messages in, 830
 V8 engine, 113
 website, 480
 Google Closure Compiler, 1104, 1108, 1109
 Google Closure Library library, 1097
 gradients, 687–689
 graphics. *See* <canvas> element
 greater-than (>) operator, 85–86
 greater-than-or-equal-to (>=) operator, 85–86
 Grunt, 1060, 1107
 Gulp, 1060, 1107

H

handleKeyPress() function, 1042
 handleResponse() method, 885
 handlers, registering, 459
 handling
 errors, 983
 failures, 394
 notification events, 1031
 push events, 1032–1033
 request failures, 887–888
 status codes, 887–888

hardware detection, 480–489
 hardwareConcurrency property, 455
 has() method, 201–202, 207–209, 212, 218, 335–336, 895–897, 1013–1014
 hasAttributeNS() method, 567
 hasChildNodes() method, 495
 hasFeature() method, 503–504
 hasFlash() function, 459
 Hash-Based Message Authentication Code (HMAC), 814
 hashchange event, 647
 hasIEPlugin() function, 458
 hasOwnProperty() method, 67, 279–280, 281–283
 hasPlug() method, 459
 hasQuickTime() function, 459
 head property, 551
 <head> element, 16
 Headers object, 895–897
 headers property, 903
 height property, 460
 hidden classes, 118–119
 hidden properties, 345
 hiding notifications, 775–776
 High Resolution Time API, 786–787
 high-performance script tools, 1105
 history object
 about, 460
 navigation, 460–461
 state management, 461–462
 HMAC-Based Key Derivation Function (HKDF), 814
 hoisting var declaration, 30–31
 host environment, 3
 href property, 576
 HTML
 elements, 507–509
 event handlers, 604–606
 JavaScript in, 13–24
 methods, 157
 templates, 791–794
 HTML5, 547
 HTML5 Constraint Validation API, 723–726
 HTML5 events, 641–647
 HTMLCollections, 1058–1059
 HTMLDocument type, 550–551
 HTML/JavaScript, decoupling, 1039–1041
 HTTP compression, 1064
 HTTP headers, 875–876

I

id property, 1018
 identically equal to (===) operator, 87–88
 identifier lookup, 113–114

- identifiers, 26, 946
- identifying
 - browser, 481–482
 - operating system, 481–482
- if statement, 90
- iframes, 571
- ignoreCase property, 134
- ignoreMethod properties, 1016–1017
- ignoreSearch property, 1016
- ignoreVary property, 1017
- image pings, 884
- images
 - drawing, 686–687
 - working with data in, 689–691
- immediately invoked function expression (IIFE), 382–384
- The Impact of Applicative Programming on Multiprocessing* (Friedman and Wise), 395
- implementing
 - observables, 1073–1076
 - Thenable interface, 400
- importing keys, 816–817
- importKey() method, 816
- importNode() method, 794
- importScripts() method, 976, 980–982, 997, 999
- importStylesheet() method, 859
- in operator, prototypes and, 281–283
- includes() method, 151, 186–187
- includeUncontrolled property, 1018
- increment operator, 68–70
- index() method, 941–943
- IndexedDB
 - about, 933
 - concurrency issues, 943
 - databases, 933–934
 - indexes, 941–943
 - insertion, 936
 - key ranges, 939–940
 - limits, 943
 - object stores, 934–935
 - querying with cursors, 937–939
 - restrictions, 943
 - setting cursor direction, 940
 - transactions, 935–936
- indexedDB property, 972
- indexedDB.open() method, 933
- indexes, 941–943
- indexing, into arrays, 174–175
- indexOf() method, 150, 186–187, 459, 835, 923
- Infinity property, 160
- info() method, 840
- inheritance
 - about, 289
 - combination, 296–297
 - constructor stealing, 294–296
 - parasitic, 298–299
 - parasitic combination, 299–301
 - prototypal, 297–298
 - prototype chaining, 289–294
- inherited methods, 128
- inheritPrototype() function, 301
- init() method, 838–839
- initCustomEvent() method, 667–668
- initKeyEvent() method, 665
- inline code, external files *versus*, 21–22
- inner() function, 366–367
- innerHTML property, 552–554, 1057–1058
- innerText property, 558–559
- input filtering, 718–721
- input patterns, 724–725
- input property, 137, 138
- insertAdjacentHTML() method, 555
- insertAdjacentText() method, 555
- insertBefore() method, 496, 497, 513, 519–520, 731
- insertCell() method, 527
- inserting
 - DOM range content, 596–597
 - iterative values, 1055
- insertion, 936
- insertNode() method, 596–597
- insertRow() method, 527
- insertRule() method, 577, 578
- install property, 1009
- installed state, 1021–1022
- installing property, 1007
- installing state, 1020–1021
- instances
 - defined, 126
 - members, 307–308
 - methods, 135–137, 400–410
 - properties, 134
 - prototypes and relationships between, 291–292
- instantiation, 304–306
- integers, 72, 143
- integrity attribute, 14, 16
- interacting, with rich text, 735–738
- internal queues, 778–779
- internal slots, proxies and, 333
- InternalError type, 827
- internals, function, 364–367
- Internet Explorer
 - common legacy errors, 844–846
 - error messages in, 830
 - event handlers, 608–610
 - event object, 615–617

- event simulation, 668–669
- legacy plugin detection, 457–459
- using `innerHTML` in legacy, 553–554
- versions, 471–472, 472–473

interpolation, 50–51

interval property, 650

intervals

- problems with, 673
- window object, 446–448

Invalid Character error, 844–845

invariants, 328–329

inversion of control, 1024–1025

iOS, 478

`isCollapsed` property, 738

`isDefaultNamespace()` method, 566

`isEqualNode()` method, 570–571

`isExtensible()` trap, 341–342

`isInteger()` method, 143

`isNaN()` function, 43–44

`isPrototypeOf()` method, 67, 291

`isSameNode()` method, 570–571

`isSecureContext` property, 972

`italics()` method, 157

`item()` method, 494, 501, 549, 573, 574

Iterable protocol, 227–229

iteration

- about, 225–226
- iterator pattern, 226–235
- spread operators and, 220–222
- using generators as default iterators, 246–247

iterative methods, 188–189

iterative values, 1055

iterator methods, 176, 311–312

iterator pattern

- about, 226–227
- custom definition, 231–233
- early termination of iterators, 233–235
- Iterable protocol, 227–229
- protocol, 229–231

J

Jasmine, 1110

`javaEnabled` property, 455

JavaScript

- about, 1–2
- characters, 144–146
- compilation, 1063
- cookies, 922–924
- frameworks (*See* frameworks)
- history of, 2–3

- in HTML, 13–24
- implementations of, 3
- libraries (*See* libraries)
- transpilation, 1063
- versions, 11–12

JavaScript APIs

- about, 743–744, 791
- Atomics API, 744–751
- Blob, 758–764
- cross-context messaging, 751–753
- drag and drop, 770–775
- Encoding API, 753–758
- File API, 758–764
- HTML templates, 791–794
- media elements, 764–770
- Notifications API, 775–776
- Page Visibility API, 776–777
- SharedArrayBuffer, 744–751
- Streams API, 777–785
- Timing APIs, 785–791
- web components, 791–808
- Web Cryptography API, 808–821

JavaScript Debugger, 842

JavaScript Object Notation. *See* JSON

JavaScript tools

- about, 1101
- automation systems, 1107
- build tools, 1107
- compilation/transpilation tools and static type systems, 1104–1105
- documentation generators, 1110–1112
- editors, 1106
- formatters, 1107–1108
- high-performance script tools, 1105
- linters, 1107–1108
- minifiers, 1109
- module bundlers, 1103–1104
- module loaders, 1102–1103
- package managers, 1101–1102
- task runners, 1107
- unit testing, 1109–1110

`join()` method, 180

jQuery, 544, 1097

`.js` extension, 15

JsDoc Toolkit, 1111

JSHint, 1108

JSLint, 1108

JSMIn, 1109

JSON

- about, 861
- arrays, 863–864

- JSON object, 865–866
- objects, 862–863
- parsing, 864–870
- parsing options, 869–870
- sending data, 893
- serialization, 864–870, 866–869
- syntax, 862–864
- JSON object, 865–866
- JSONP, 884–885
- JSPM, 1102, 1103
- JsUnit, 1110

K

- key codes, 635–636
- Key Derivation Functions (KDF), 814
- key() method, 930, 931
- key property, 932
- key ranges, 939–940
- keyboard events, 634–640, 664–667
- keydown event, 634
- keyPath property, 942
- keypress event, 634
- keys
 - deriving from master keys, 817–818
 - exporting, 816–817
 - importing, 816–817
- keys() method, 214, 1013–1014, 1015
- keyup event, 634
- keywords, 28
- Konqueror, 476

L

- labeled statement, 93
- lambda functions, 370
- language
 - about, 25
 - data types, 36–68
 - functions, 98–100
 - keywords and reserved words, 28
 - operators, 68–89
 - statements, 90–98
 - syntax, 25–28
 - variables, 29–36
- language property, 14, 455
- languages property, 455
- lastChild() method, 588
- lastElementChild property, 546
- lastIndex property, 134

- lastIndexOf() method, 150, 186–187
- last-in-first-out (LIFO) structure, 180
- lastMatch property, 137, 138
- lastModifiedDate property, 759
- lastParen property, 137, 138
- left property, 460
- left shift (<<), 76
- leftContext property, 137, 138
- length property, 573, 708
- less-than (<) operator, 19, 85–86
- less-than-or-equal-to (<=) operator, 85–86
- let declaration, 31–34, 36, 111–112
- level property, 488
- libraries
 - about, 1095, 1097
 - The Dojo Toolkit, 1098
 - Google Closure Library, 1097
 - jQuery, 1097
 - Lodash, 1098
 - MooTools, 1098
 - Prototype, 1098
 - qooxdoo, 1098
 - Underscore.js, 1097
- lifecycles
 - custom element hooks, 805–806
 - dedicated workers, 977–979
 - notification of callbacks, 776
 - service worker, 1019–1024
 - shared workers, 1000–1001
- Lightbox, 1099
- limits
 - IndexedDB, 943
 - Web Sockets, 933
- <link> element, 523–525
- link(url) method, 157
- linters, 1107–1108
- Liskov, Barbara
 - Promises: Linguistic Support for Efficient Asynchronous Procedure Calls in Distributed Systems*, 395
- listeners, 601
- literals, template, 49–50
- LLVM, 1105
- load event, 620–622, 767, 880–881
- load() method, 748
- loadeddata event, 767
- loadedmetadata event, 767
- loading files as Blobs, 894
- loadstart event, 767
- localeCompare() method, 156
- localStorage object, 932

- location object
 - about, 450–451
 - manipulating, 452–454
 - query string arguments, 451–452
- location property, 972
- locks property, 455
- Lodash library, 1098
- log errors, 839–840
- log() method, 840, 842–843
- logError() function, 839
- logging
 - messages to console, 840–841
 - messages to pages, 842–843
- lookbehinds, 1080–1081
- lookupNamespaceURI() method, 566
- lookupPrefix() method, 566
- loop property, 765
- loops
 - optimizing, 1050–1051
 - unrolling, 1051–1053
- loose coupling, 1039–1042

M

- main() method, 697–698
- maintainability
 - about, 1035–1036
 - code conventions, 1036–1039
 - external files and, 21
 - loose coupling, 1039–1042
 - maintainable code, 1036
 - programming practices, 1043–1047
- malloc(), 191–192
- managing
 - memory, 117–122
 - observer scope with MutationObserverInit, 534–540
 - state with executor, 397–398
- manipulating
 - location object, 452–454
 - methods for, 184–186
 - nodes, 495–497
 - tables, 525–527
- map() method, 188–189
- Map type
 - about, 201
 - basic API, 201–203
 - choosing between objects and maps, 206
 - order and iteration, 203–205
- maps, choosing between objects and, 206
- mark-and-sweep, 115
- markup insertion, 552–556, 558–560
- master keys, deriving keys from, 817–818
- match() method, 153, 1015
- matchAll() method, 1015
- matches() method, 545
- Math object
 - about, 161
 - max() method, 162
 - min() method, 162
 - other methods, 164–165
 - properties, 162
 - random() method, 163–164
 - rounding methods, 163
- Math.ceil() method, 163
- Math.floor() method, 163
- Math.fround() method, 163
- max() method, 162
- maximizing parallelization, 431–434
- maximum cache storage, 1017
- maximum touch points, 489
- maximumAge property, 485
- maxTouchPoints property, 455
- measureText() method, 682
- media elements
 - about, 764
 - Audio type, 770
 - codec support detection, 769
 - custom media players, 768–769
 - events, 767–768
 - properties, 765–766
- media property, 576
- mediaCapabilities property, 455
- mediaDevices property, 455
- Member Not Found error, 845
- memory
 - events and, 659–662
 - issues with, 555–556
 - managing, 117–122, 434–435
 - MutationObserver, 541–542
- memory leaks, 119–120, 381–382
- merging
 - objects, 257–260
 - typed arrays, 198–200
- Message API, 1009–1010
- MessageChannel, 984–986
- MessagePorts, dedicated workers and implicit, 976–977
- metadata, browser, 482–488
- Meteor framework, 1096
- method property, 708
- methods. *See also specific methods*
 - arithmetic, 745–747
 - array flattening, 1082–1084
 - bitwise, 745–747

- conversion, 179–180
- copy and fill, 176–178
- date-formatting, 129
- date/time component, 129–131
- Document Object Model (DOM), 573–574
- form field, 713–714
- function, 367–370
- generator, 311–312
- HTML, 157
- inherited, 128
- instances, 135–137, 400–410
- iterative, 188–189
- iterator, 176, 311–312
- manipulation, 184–186
- naming in WebGL, 695
- privileged, 384
- prototype, 308–309
- queue, 181–182
- reduction, 189–190
- reordering, 182–184
- rounding, 163
- search and location, 186–188
- stack, 180–181
- static class, 309–310
- string case, 153
- string inclusion, 151
- string location, 150
- string pattern-matching, 153–156
- string trimming, 1085
- string-manipulation, 148–149
- URI-encoding, 158–159
- working with, 292–294
- Michaux, Peter
 - “Feature Detection: State of the Art Browser Scripting,” 467
- MIME type, 20–21
- mimeTypes property, 455
- min() method, 162
- minification, 1062–1064
- minifiers, 1109
- minimizing
 - live updates, 1056–1057
 - statement count, 1054–1056
- minus signs (--), 69
- mobile consoles, 824
- Mocha, 1110
- modes, document, 22–23
- modifier keys, 629–630
- module behavior, 959–960
- module bundlers, 1061, 1103–1104
- module dependencies, 946
- module exports, 960–963
- module identifiers, 946
- module imports, 963–965
- module loaders/loading, 946–947, 957, 959, 1102–1103
- module passthrough exports, 965
- module pattern, 387–388, 946–950
- module systems, 950–952
- module-augmentation pattern, 388–389
- modules
 - about, 945
 - asynchronous dependencies, 948
 - circular dependencies, 949–950
 - entry points, 947
 - ES6 modules, 958–966
 - module pattern, 946–950
 - module systems, 950–952
 - pre-ES6 module loaders, 953–957
 - programmatic dependencies, 948
 - static analysis, 948–949
 - strict mode, 1093
 - tagging, 958–959
 - worker, 965–966
- modulus (%) operator, 82
- moo.fx, 1099
- Mootools (website), 480
- MooTools library, 1098
- Mosaic browser, 470
- mouse events, 625–634, 663–664
- mousedown event, 625
- mouseenter event, 625
- mouseleave event, 625
- mousemove event, 625
- mouseout event, 625
- mouseover event, 626
- mouseup event, 626
- mousewheel event, 633
- moveEnd() method, 718
- moveStart() method, 718
- moving options, 731
- Mozilla Firefox, error messages in, 830
- Mozilla Project, 11–12, 471
- mozRequestAnimationFrame() method, 672
- multiline property, 134
- multiple property, 727
- multiple variable declarations, 1054–1055
- multiplexing MutationObserver, 532–533
- multiplicative operators, 80–82
- multiply (*) operator, 80–81
- mutation events, 641
- MutationObserver API
 - about, 529
 - async callbacks, 540–541
 - basic usage, 529–534
 - callbacks, 530–532

- controlling observer scope with
 - MutationObserverInit object, 534–540
- garbage collection, 541–542
- memory, 541–542
- multiplexing, 532–533
- MutationRecords, 530–532
- performance, 541–542
- record queue, 540–541
- references, 541
- reusing, 533–534

MutationRecords, 530–532, 542

muted property, 765

N

name property, 708, 711, 758, 942, 976, 979, 999

named capture groups, 1081

named export, 961

named slots, 801

namedItem() method, 501

NamedNodeMap, 568

names, for functions, 351–352

namespace support, 856–857

NaN (Not a Number), 43–44, 160

National Center for Supercomputing Applications (NCSA), 470

navigating

- history object, 460–461
- windows, 442–446

Navigation Timing API, 789–790

navigatorPreload property, 1007

navigator object

- about, 454–456
- detecting plug-ins, 456–459
- registering handlers, 459

navigator property, 972

navigator.connection property, 486

navigator.deviceMemory property, 489

navigator.geolocation property, 483

navigator.hardwareConcurrency property, 489

navigator.maxTouchPoints property, 489

navigator.onLine property, 486

navigator.oscpu property, 481

navigator.platform property, 481–482

navigator.vendor property, 481

nested destructuring, 266–267

nesting asynchronous callbacks, 394–395

Netscape, 2

Netscape Communications, 471

Netscape Communicator 4, 472–473

Netscape Navigator, 471–472

network requests, 871–918

NetworkInformation API, 486–487

networkState property, 765

new.target object, 367

newValue property, 932

next() method, 58, 61, 229–231, 237–238, 238–246, 247–249, 1072–1073

nextElementSibling property, 546

nextNode() method, 587–588

nextSibling() method, 588

NodeIterator type, 585–588

NodeList object, 528–529

nodeName property, 493

nodes

- about, 492
- Attr type, 520–521
- CDATASection type, 518
- changes to, 566, 570–571
- Comment type, 517–518
- Document type, 498–506
- DocumentFragment type, 519–520
- DocumentType type, 518–519
- Element type, 506–514
- hierarchy of, 492–521
- manipulating, 495–497
- relationships, 494–495
- Text type, 514–517
- types, 492–497

nodeValue property, 493

nonfatal errors, 838–839

non-function prototype/class members, 310

non-reentrant promise methods, 405–407

normalize() method, 147–148, 497, 516, 517

normalizing text nodes, 516

<noscript> element, 23–24

Not a Number (NaN), 43–44

not equal (!=) operator, 833–835

not indentially equal to (!==) operator, 88

NOT (!) operator (logical), 77–78

NOT (~) operator (bitwise), 73–74

not-equal (!=) operator, 86–87

notifications

- displaying, 1030–1031
- push, 1030–1033

Notifications API, 775–776

notify() method, 419–421

npm, 1101–1102, 1107

null comparisons, avoiding, 1045–1046

Null type, 39

number conversions, 44–46

Number() function, 44–45, 71, 80, 84

Number property, 160

Number type, 41–46, 141–143

numeric ranges, 724

navigator.getBattery() method, 487

O

- Object API, Reflect API *versus*, 330
- object definitions. *See* reference types
- object() function, 297, 299
- object literals
 - notation for, 168
 - using, 1055–1056
- object pools, 120–122
- Object property, 160
- Object type, 67–68
- Object URLs, Blobs and, 762–763
- Object.assign() method, 258–260, 318
- Object.defineProperties() method, 255
- Object.defineProperty() method, 286
- Object.entries() method, 284
- Object.fromEntries(), 1084–1085
- Object.getOwnPropertyDescriptor() method, 256–257
- Object.getOwnPropertyNames() method, 283
- objects. *See also specific objects*
 - about, 251–252
 - choosing between maps and, 206
 - creating, 268–289
 - destructuring, 264–268
 - enhanced syntax, 261–264
 - factory pattern, 269
 - function constructor pattern, 269–273
 - identity and equality, 260–261
 - iteration, 284–289
 - JSON, 862–863
 - merging, 257–260
 - ownership of, 1043–1044
 - prototype pattern, 273–284
 - strict mode, 1088–1089
 - transferable, 988–990
- objectSayColor() function, 370
- objectStore() method, 935
- objectStore property, 942
- Object.values() method, 284
- observables, 347, 1073–1076
- observe() method, 529–530, 535
- observing
 - attribute mutations, 535–536
 - character data mutations, 536–537
 - child mutations, 537–539
 - subtree mutations, 539–540
- O’Callahan, Robert, 673
- octal literal, 1093
- offset dimensions, 579–581
- offsetHeight property, 579
- offsetLeft property, 579
- offsetTop property, 579
- offsetWidth property, 579
- ok property, 903
- oldValue property, 932
- onchange property, 487
- onconnect property, 1000
- onerror property, 975, 999
- onLine property, 455
- only() method, 939–940
- onmessage property, 975
- onmessageerror property, 975
- open() method, 504–506, 846, 872–875, 875–876, 876–877, 877–878, 882
- openCursor() method, 937, 941–943
- opening windows, 442–446
- openKeyCursor() method, 941–943
- openWindow() method, 1018
- Opera, 476–478, 830
- operating systems, identifying, 481–482
- operators
 - about, 68
 - additive, 82–85
 - assignment, 88–89
 - bitwise, 72–77
 - Boolean, 77–80
 - comma, 89
 - conditional, 88
 - equality, 86–88
 - exponentiation, 82
 - multiplicative, 80–82
 - relational, 85–86
 - unary, 68–72
- optimizing
 - DOM interactions, 1056–1059
 - loops, 1050–1051
- opting-in, 1087
- optional catch binding, 1086
- options
 - adding, 730
 - moving, 731
 - removing, 730–731
 - reordering, 731
 - selecting, 728–729
- options property, 727
- OR (|) operator (bitwise), 74–75
- OR (||) operator (logical), 79–80
- order of execution, sibling, 407
- orientation property, 460, 482
- orientationchange event, 647–648
- origin property, 972
- oscpu property, 455, 481
- outer() function, 366–367
- outerHTML property, 554–555
- outerText property, 560
- overflow, of values, 200
- overloading, 355–356

overrideMimeType() method, 879–880
 ownerDocument property, 495
 ownerNode property, 576
 ownerRule property, 577
 ownKeys() trap, 339

P

package managers, 1101–1102
 padEnd() method, 152
 padStart() method, 152
 page coordinates, 628
 Page Visibility API, 776–777
 pagehide event, 645–646
 pageshow event, 645–646
 parallel composition, of promises, 414–416
 parallelization, maximizing, 431–434
 parameter context matching, 268
 parameters
 default scope of, 358
 default values for, 356–358
 functions, 1090–1091
 sending in a request body, 893
 traps, 326–328
 using, 858–859
 parasitic combination inheritance, 299–301
 parasitic inheritance, 298–299
 parentNode() method, 588
 parentRule property, 573, 577
 parentStyleSheet property, 576, 577
 parse() method, 865, 869–870
 parsed state, 1020
 parseFloat() function, 44, 46
 parseFromString() method, 850–851
 parseInt() function, 44–46, 1093
 parsing
 JSON, 864–870
 options for, 869–870
 partial reads, Blobs and, 761–762
 partial text selection, 717–718
 passing arguments, 295
 passthrough proxies, creating, 324–325
 Password-Based Key Derivation Function 2 (PBKDF2), 814
 paths, drawing, 679–681
 patternMismatch property, 725
 patterns, 139, 689
 pause event, 767
 pause() method, 768–769
 paused property, 766
 pending state, 396
 performance
 about, 1047
 choosing an approach, 1049–1054
 events and, 659–662
 garbage collection and, 116–117
 issues with, 555–556
 minimizing statement count, 1054–1056
 MutationObserver, 541–542
 optimizing DOM interactions, 1056–1059
 scope-awareness, 1047–1049
 throttling, 674–675
 performance property, 972
 Performance Timeline API, 788–791
 performance.now(), 787
 PERMISSION_DENIED error, 484
 permissions, Notifications API, 775
 permissions property, 455
 permutation cycle, 809
 Person() function, 272
 pipeThrough() method, 784–785
 piping streams, 784–785
 pixel ratio, 439–440
 pixelDepth property, 460, 482
 pixels, reading, 703–704
 platform property, 456, 481–482
 Platform.js (website), 480
 play event, 767
 play() method, 768–769, 770
 playbackRate property, 766
 played property, 766
 playing event, 767
 plug-ins, detecting, 456–459
 plugins property, 456
 plus signs (++), 68
 pop() method, 180–181, 198–200
 popping up windows, 442–444
 pop-up blockers, 445–446
 port property, 999
 position, for window object, 439–440
 POSITION_UNAVAILABLE error, 484
 POST requests, 877–878
 postfix decrement, 69
 postfix increment, 69
 postMessage() method, 752–753, 761, 975, 976, 983–984, 1018, 1026
 predicate search, 187–188
 pre-ES6 module loaders, 953–957
 prefix decrement, 69
 prefix increment, 68
 preflighted requests, 883
 premultipliedAlpha property, 694
 preserveDrawingBuffer property, 694
 preventDefault() method, 612, 614, 616, 618, 709, 719

- preventExtensions() trap, 342
- previousElementSibling property, 546
- previousNode() method, 587–588
- previousSibling() method, 588
- primitive types, 36
- primitive values
 - about, 101
 - argument passing, 103–105
 - copying values, 103
 - determining type, 105–106
 - dynamic properties, 102–103
- primitive wrapper types
 - about, 139–140
 - Boolean type, 141
 - Number type, 141–143
 - String type, 144–157
- private variables
 - about, 209–211, 384–385
 - module pattern, 387–388
 - module-augmentation pattern, 388–389
 - static, 385–386
- privateFunction() function, 384–385
- privileged method, 384
- processor
 - cores, 489
 - resetting, 859
- product property, 456
- productSub property, 456
- programmatic dependencies, 948
- programming, practices for, 1043–1047. *See also* asynchronous programming
- progress event, 767, 881
- progress events
 - about, 880
 - load event, 880–881
 - progress event, 881
- progress notifications, for promises, 419–421
- promise canceling, 418–419
- promise chaining, 410–417
- promise graphs, 413
- Promise.all() method, 413, 414–415, 416, 421
- Promise.prototype.catch() method, 403–404
- Promise.prototype.finally() method, 404–405
- Promise.prototype.then() method, 400–403
- Promise.race() method, 413, 415–416
- Promise.reject() method, 399, 403, 409, 426
- Promise.resolve() method, 398–399, 401, 402, 403, 422
- promises
 - about, 395
 - basics of, 395–400
 - casting with Promise.resolve() method, 398–399
 - controlling state with executor, 397–398
 - extensions, 418–421
 - instance methods, 400–410
 - non-reentrant promise methods, 405–407
 - parallel composition, 414–416
 - progress notifications for, 419–421
 - Promise.prototype.catch() method, 403–404
 - Promise.prototype.finally() method, 404–405
 - Promises/A+ specification, 395
 - rejecting, 396–397, 408–410
 - rejection with Promise.reject() method, 399
 - resolved values, 396–397, 408
 - serial composition, 416–417
 - sibling handler order of execution, 407
 - states, 396
 - synchronous/asynchronous execution duality, 399–400
 - utility of, 396–397
- Promises: Linguistic Support for Efficient Asynchronous Procedure Calls in Distributed Systems* (Liskov and Shrira), 395
- Promises/A+ specification, 395
- prompt() method, 449
- properties. *See also specific properties*
 - accessor, 254–255
 - avoiding unnecessary lookups, 1049–1050
 - of constructors, 137–139
 - data, 252–254
 - defining multiple, 255–256
 - Document Object Model (DOM), 573–574
 - dynamic, 102–103
 - form field, 711–713
 - function, 367–370
 - hidden, 345
 - instance, 134
 - media elements, 765–766
 - reading attributes, 256–257
 - tracking access to, 344
 - types of, 252–255
 - using symbols as, 56–57
 - validating, 345–346
- propertyIsEnumerable() method, 67
- proprietary extensions
 - about, 557
 - children property, 557
 - contains() method, 557–558
 - markup insertion, 558–560
 - scrolling, 560
- Prototype library, 1098
- prototypal inheritance, 297–298
- prototype chaining, 289–294
- prototype pattern, 273–284
- prototypes
 - default, 291

- dynamic nature of, 286–287
 - hierarchy of, 278–281
 - how they work, 274–278
 - instance relationships and, 291–292
 - methods and accessors, 308–309
 - native object, 287–288
 - in operator and, 281–283
 - problems with, 288–289
- proxies
- about, 323
 - considerations and shortcomings, 332–333
 - creating passthrough, 324–325
 - defining traps, 325–326
 - fundamentals of, 324–333
 - proxy patterns, 344–347
 - proxy traps, 333–344
 - proxying, 331
 - Reflect API, 326–328
 - reflect methods, 333–344
 - revocable, 329
 - trap invariants, 328–329
 - trap parameters, 326–328
 - utility of Reflect API, 329–331
- pseudorandom number generator (PRNG), 808–809
- publicMethod() function, 384–385
- Push API, 1010
- push events
- handling, 1032–1033
 - subscribing to, 1031–1032
- push() method, 180–181, 198–200
- pushManager property, 1007
- pushState() method, 461–462
- put() method, 935, 936, 1014

Q

- qoosdoo library, 1098
- query string arguments, 451–452
- queryCommandState() method, 738
- queryCommandValue() method, 738
- querying, with cursors, 937–939
- querySelector() method, 544
- querySelectorAll() method, 544–545
- queue
- Async iterator, 1070–1072
 - methods for, 181–182
- quirks mode, 22
- qUnit, 1110

R

- random() method, 163–164
- random number generation, 808–810
- range of values, 42–43
- rangeCount property, 738
- RangeError property, 160, 827
- rangeOverflow property, 725
- ranges
- about, 590
 - cleanup, 598–599
 - cloning DOM, 598
 - collapsing DOM, 597
 - comparing DOM, 597–598
 - complex selection in DOM, 592–593
 - in DOM, 590–591
 - inserting DOM range content, 596–597
 - interacting with DOM range content, 593–595
 - numeric, 724
 - simple selection in DOM, 591–592
- rangeUnderflow property, 725
- ratechange event, 767
- raw strings, 53
- React framework, 1095–1096
- read() method, 780, 910–911
- readability, of code, 1037
- readable streams, 778, 779–781
- ReadableStream, 909–914
- ReadableStreamDefaultController, 779
- ReadableStreamDefaultReader, 780–781
- readAsArrayBuffer() method, 759
- readAsBinaryString() method, 759
- readAsDataURL() method, 759
- readAsText() method, 759
- reading
- pixels, 703–704
 - property attributes, 256–257
 - response status information, 903–904
 - responses, 886
- readOnly property, 711
- reads, Atomic API, 747–748
- ready property, 1006
- readyState property, 550, 766
- readystatechange event, 644–645
- receiving data, 916
- record queue, 540–541
- rectangles, drawing, 677–679
- recursive function, 372–373
- redirected property, 903
- reduce() method, 189–190
- reduceRight() method, 189–190
- reduction methods, 189–190
- redundant state, 1019, 1024
- reference counting, 115–116
- reference types. *See also* collection reference types
- about, 125–126
 - Date type, 126–131
 - primitive wrapper types, 139–157

- RegExp type, 131–139
- singleton built-in objects, 157–166
- reference values
 - about, 101
 - argument passing, 103–105
 - copying values, 103
 - determining type, 105–106
 - dynamic properties, 102–103
- ReferenceError type, 160, 827
- references
 - events, 654–659
 - MutationObserver, 541
- Reflect API, 326–328, 329–331, 333–344
- RegExp property, 160
- RegExp type
 - about, 131–133
 - constructor properties, 137–139
 - instance methods, 135–137
 - instance properties, 134
 - pattern limitations, 139
- register() method, 1004, 1006–1007, 1020
- registering handlers, 459
- registerProtocolHandler() method, 456, 459
- registration property, 1009
- regular expressions, enhancements to, 1079–1082
- reject() function, 408
- reject() handling, 1072
- rejected state, 396, 397
- rejecting
 - error handling for, 408–410
 - promises, 408–410
 - reasons for, 396–397
- relational operators, 85–86
- reload() method, 454
- remote resources, 871–918
- remove() method, 549, 727
- removeAllRanges() method, 739
- removeAttribute() method, 510–511, 512, 520–521
- removeAttributeNS() method, 567
- removeChild() method, 496, 499, 661–662, 730–731
- removeEventListener() method, 607–608, 611–615
- removeItem() method, 930, 931, 932
- removeNamedItem() method, 512
- removeNamedItemNS() method, 568
- removeParameter() method, 858–859
- removeProperty() method, 573, 574
- removeRange() method, 739
- removeReference() method, 209, 219
- removing
 - event handlers, 661–662
 - options, 730–731
- reordering
 - methods for, 182–184
 - options for, 731
- repeat() method, 152
- replace() method, 154, 155, 453–454
- replaceChild() method, 496, 497, 499, 513, 661–662
- replacer function, 869
- replaceState() method, 462
- request failures, 887–888
- Request object, 897–900
- requestAnimationFrame, 672–675
- requestMediaKeySystemAccess() method, 456
- requestPermission() method, 775
- requests
 - aborting, 894–895
 - dispatching, 886
 - Fetch API, 906–914
- require() method, 953–954
- RequireJS, 1103
- reserved words, 28
- reset() method, 708, 710, 859
- resetting
 - forms, 709–710
 - processor, 859
- resize event, 623
- resizeBy() method, 441
- resizeTo() method, 441
- resolve() method, 406, 408
- resolved values, 396–397, 408
- Resource Timing API, 790–791
- Response object, 901–905
- Response.error() method, 902
- Response.redirect() method, 902
- responses, Fetch API, 906–914
- responseText property, 873
- responseXML property, 873
- rest operator, 1076–1077
- rest parameter, 360–361
- restore() method, 685, 686
- restrictions
 - cookies, 920–921
 - IndexedDB, 943
 - Web Sockets, 933
- resuming async functions, 427–430
- retrieving selected text, 717
- return() method, 233–235, 247–248
- return statement, 99, 826
- returning asynchronous values, 393–394
- returnValue property, 616
- reusing MutationObserver, 533–534
- reverse() method, 182–184, 836
- reverseSort() function, 836
- reviver function, 869

revocable() method, 329
 revocable proxies, 329
 rich text

- editing, 734–740
- in forms, 740
- selections of, 738–740

 rightContext property, 137, 138
 Rivest-Shamir-Adleman (RSA), 812
 Rollup, 1104
 rotate() method, 683, 684–685
 rotationRate property, 650
 rounding methods, 163
 RSA-OAEP, 813
 RSA-PSS, 813
 RSASSA-PKCS1-v1_5, 812
 rtt property, 487
 rules, 578–579

S

Safari, error messages in, 830
 safe integers, 143
 safety, capability detection and, 467
 SameValueZero operation, 203
 save() method, 685
 saveData property, 487
 sayAge() method, 297, 438
 sayColor() method, 161, 365–366, 369, 370
 sayName() method, 252, 272–273, 274, 278, 296, 1044
 scale() method, 683
 scope

- about, 106–108
- var declaration, 29–30

 scope chain, 107, 108–109
 scope property, 1007
 scope-awareness, 1047–1049
 screen coordinates, 628–629
 screen object, 459–460
 screen.colorDepth property, 482
 screen.orientation property, 482
 screen.pixelDepth property, 482
 <script> element

- about, 13–16, 521–523, 524
- asynchronous scripts, 17–18
- changes in XHTML, 19–20
- deferred scripts, 17
- deprecated syntax, 20–21
- dynamic script loading, 18
- tag placement, 16

 scripting

- forms (*See* forms)
- select boxes, 726–731
 - text boxes, 715–726
- scripts
 - asynchronous, 17–18
 - deferred, 17
 - dynamic loading, 18, 521–523
 - template, 794
- scriptURL property, 1008
- scroll dimensions, 582–583
- scroll event, 624
- scrollHeight property, 582
- scrolling, 560
- scrollIntoView() method, 556–557
- scrollLeft property, 582
- scrollTop property, 582
- scrollWidth property, 582
- search and location methods, 186–188
- search() method, 154
- Secure Hash Algorithms, 810
- security restrictions
 - about, 917
 - dedicated workers, 974–975
 - service workers, 1008
 - for windows, 445
- seekable property, 766
- seeked event, 767
- seeking property, 766, 767
- select boxes, scripting, 726–731
- select event, 716
- select() method, 716, 717, 718
- selectAllChildren() method, 739
- selectedIndex property, 727
- selectFrom() function, 164
- selecting
 - options, 728–729
 - text, 716–718
- selectNode() method, 591–592, 592–593
- selectNodeContents() method, 591–592, 592–593
- Selectors API, 544–545
- selectorText property, 577
- self property, 972
- send() method, 873, 875–876, 916
- sendBeacon() method, 456, 914
- sending
 - cross-origin requests, 894
 - data, 916
 - files, 893–894
 - JSON data, 893
 - parameters in a request body, 893
- serial composition, of promises, 416–417
- serial promise execution, 434
- serialization
 - of forms, 732–733
 - JSON, 864–870, 866–869
 - options for, 866–869

- serialize() function, 733
- serializeToString() method, 852
- service workers
 - about, 971
 - cache, 1012–1017
 - clients, 1017–1018
 - consistency and, 1018–1019
 - creating, 1004–1005
 - forced operation, 1025–1026
 - intercepting fetch events, 1028–1030
 - lifecycle, 1019–1024
 - managing file caching with updateViaCache, 1025
 - messaging, 1026–1028
 - persistence of, 1024–1025
 - push notifications, 1030–1033
 - scope limitations, 1010–1012
 - security restrictions, 1008
 - state, 1009
 - updating, 1024
- ServiceWorker object, 456, 1007–1008
- ServiceWorkerContainer, 1004–1006
- ServiceWorkerGlobalScope, 1008–1010
- ServiceWorkerRegistration object, 1006–1007
- sessionStorage object, 930–932
- set() method, 201–202, 207–209, 895–897, 927
- set operations, defining formal, 215–217
- set() trap, 334–335
- Set type
 - about, 211
 - basic API, 211–213
 - defining formal set operations, 215–217
 - order and iteration, 213–215
- setAll() method, 927
- setAttribute() method, 510–511, 512, 520–521
- setAttributeNode() method, 521
- setAttributeNodeNS() method, 568
- setAttributeNS() method, 568
- setClipboardText() method, 721
- setData() method, 720–721, 772–773
- setDragImage() method, 774–775
- setEnd() method, 592–593
- setEndAfter() method, 592
- setEndBefore() method, 592
- setInterval() method, 447, 672, 673, 972
- setItem() method, 930
- setName() method, 105, 386
- setNamedItemsNS() method, 568
- setParameter() method, 858–859
- setProperty() method, 573
- setPrototypeOf() method, 277–278, 340–341
- setRequestHeader() method, 875–876
- setSelectionRange() method, 717, 718
- setStart() method, 592–593
- setStartAfter() method, 592
- setStartBefore() method, 592
- setTimeout() method, 446–447, 672, 673, 674, 972
- setting cursor direction, 940
- setTransform() method, 683
- setUserData() method, 571
- setVersion() method, 934
- shaders, WebGL, 697–698
- shadow DOM, 795–802
- shadow root, 797
- shadowBlur property, 687
- shadowColor property, 687
- shadowOffsetX property, 687
- shadowOffsetY property, 687
- shadows, 687
- share() method, 456
- shared web worker, 971
- shared workers
 - about, 997–1000
 - connecting to, 1001–1002
 - creating, 997–998
 - lifecycle, 1000–1001
- SharedArrayBuffer, 744–745, 990–993
- SharedWorker(), 998–999
- SharedWorkerGlobalScope, 999–1000
- shift() method, 181–182, 198–200
- showMessage() method, 605–606
- showNotification() method, 1007, 1032–1033
- showValue() function, 1089
- Shrira, Liuba
 - Promises: Linguistic Support for Efficient Asynchronous Procedure Calls in Distributed Systems*, 395
- Siblime Text, 1106
- side effect, 69
- sign bit, 72
- signed right shift (>>), 76
- signing messages with asymmetric keys, 819–820
- simple type results, 854–855
- simulating events, 662–669
- single node results, 854
- single plus sign (+), 70–72
- single quotes ('), 46, 47
- single-line comment, 26
- singleton built-in objects
 - about, 157
 - Global object, 157–161
 - Math object, 161–165
- single-use streams, 908–909
- size, of window object, 440–441
- size property, 727, 758
- skipWaiting() method, 1009
- sleep() function, 430–431
- slice() method, 148–149, 184–186, 191, 761–762

- small() method, 157
- Smith, Kevin, 418
- software detection, 480–489
- some() method, 188–189
- sort() method, 182–184, 363, 467, 836
- source property, 134
- SPDY/HTTP2, 21–22
- Spectre, 787
- splice() method, 185–186, 198–200
- split() method, 155–156
- splitText() method, 517–518
- splitting text nodes, 517
- Spolsky, Joe (blogger), 144
- spoofing user-agents, 479
- spread arguments, 359–360
- spread operators, 220–222, 1077–1078
- src attribute, 14, 15, 766
- srcElement property, 616
- stack methods, 180–181
- stack traces, 434–435
- stalled event, 768
- standards mode, 22–23
- start() method, 779, 977
- start property, 766
- startContainer property, 590
- startMessage() method, 1006
- startOffset property, 590, 592
- startsWith() method, 151, 288
- state property, 1008
- statement context, 168
- statements
 - for, 91–92
 - with, 95–96, 109, 1048–1049, 1093
 - about, 27–28, 90
 - break, 94–95
 - catch, 109
 - continue, 94–95
 - do-while, 90–91
 - for-in, 92–93
 - for-of, 93
 - if, 90
 - labeled, 93
 - return, 99, 826
 - switch, 96–98
 - try/catch, 33, 825–829, 831, 840
 - while, 91
- states, promises, 396
- static allocation, 120–122
- static analysis, 948–949
- static class methods/accessors, 309–310
- static code analyzer, 833
- static private variables, 385–386
- static type systems, 1104–1105
- status codes, 887–888
- status property, 873, 903
- statusText property, 873, 903
- stencil property, 693
- stepDown() method, 724
- stepMismatch property, 725
- stepUp() method, 724
- sticky property, 134
- stopImmediatePropagation() method, 612
- stopping async functions, 427–430
- stopPropagation() method, 612, 614, 616, 618
- storage property, 456, 932
- Storage type, 929–930
- store() method, 748
- strategies
 - for async functions, 430–435
 - for error handling, 832
- stream decoding, 756–758
- stream encoding, 754–755
- Streams API
 - about, 777–779
 - pipng streams, 784–785
 - readable streams, 779–781
 - transform streams, 782–783
 - writable streams, 781–782
- strict equivalence, 186–187
- strict mode
 - about, 27, 1087
 - classes, 1093
 - coercion, 1092
 - functions, 1089–1092
 - modules, 1093
 - objects, 1088–1089
 - opting-in, 1087
 - variables, 1088
- strike() method, 157
- string case methods, 153
- String() function, 49, 83
- string inclusion methods, 151
- string indentation, 867–868
- string iterators, 152–153
- string location methods, 150
- string pattern-matching methods, 153–156
- String property, 160
- string trimming methods, 1085
- String type
 - about, 46–53, 144
 - destructuring, 152–153
 - HTML methods, 157
 - JavaScript character, 144–146
 - localeCompare() method, 156
 - normalize() method, 147–148
 - padEnd() method, 152
 - padStart() method, 152
 - repeat() method, 152

- string case methods, 153
- string inclusion methods, 151
- string iterators, 152–153
- string location methods, 150
- string pattern-matching methods, 153–156
- string-manipulation methods, 148–149
 - trim() method, 151
- String.fromCharCode() method, 637, 719
- stringify() method, 865, 866–867
- string-manipulation methods, 148–149
- strings
 - converting to, 48–49
 - raw, 53
- strokeRect() method, 677–679
- strokes, 677
- strokeText() method, 681–683
- structured clone algorithm, 987–988
- style property, 578
- style sheets, 576–579
- <style> element, 523–525
- styles
 - computed, 575–576
 - declarations, 35–36
 - Document Object Model (DOM), 572–584
 - dynamic, 523–525
- sub() method, 157
- subclasses, 972–973
- subcookies, 925–928
- SubCookieUtil.getAll() method, 926
- submit() method, 708, 709, 710, 740
- submitting forms, 708–709
- subscribing to push events, 1031–1032
- substr() method, 149
- substring() method, 139, 148–149, 717, 835
- SubtleCrypto object, 810–821
- SubtleCrypto.decrypt() method, 820
- SubtleCrypto.digest() method, 811
- SubtleCrypto.encrypt() method, 820
- SubtleCrypto.generateKey() method, 814–816
- SubtleCrypto.sign() method, 819–820
- SubtleCrypto.unwrapKey() method, 821
- SubtleCrypto.verify() method, 819–820
- SubtleCrypto.wrapKey() method, 821
- subtract (-) operator, 84–85
- subtree mutations, observing, 539–540
- subtree property, 534
- sum() function, 99, 352, 841
- sup() method, 157
- super() method, 314–316, 803
- supplementary plane, 145
- surrogate pair, 145
- surroundContents() method, 596–597, 739
- swapColors() function, 108
- switch statement, 96–98
- Symbol property, 54–55, 160
- Symbol type, 54–67
- Symbol.asyncIterator function, 58–59
- Symbol.for(), 55–56
- Symbol.hasInstance function, 59
- Symbol.isConcatSpreadable function, 60
- Symbol.iterator function, 60–61
- Symbol.match function, 61–62
- Symbol.prototype.description, 1085
- Symbol.replace function, 62–63
- symbols
 - using as properties, 56–57
 - well-known, 57–67
- Symbol.search function, 63–64
- Symbol.species function, 64
- Symbol.split function, 64–65
- Symbol.toPrimitive function, 65–66
- Symbol.toStringTag function, 66
- Symbol.unscopables function, 66–67
- synchronous programming, asynchronous programming *versus*, 392–393
- synchronous tasks, 411
- synchronous/asynchronous execution duality, 399–400
- syntax
 - about, 25
 - case-sensitivity, 26
 - comments, 26
 - deprecated, 20–21
 - identifiers, 26
 - statements, 27–28
 - strict mode, 27
- Syntax Error, 845–846
- SyntaxError object, 160, 827
- system dialogs, 448–450
- SystemJS, 1103
- The System Cannot Locate the Resource Specified error, 846

T

- tabForward() function, 722
- tabIndex property, 711
- <table> element, 525–527
- tables, manipulating, 525–527
- tag functions, 51–53
- tagging modules, 958–959
- tail call optimization, 373–376
- takeRecords() method, 541
- target property, 612, 708
- task runners, 1060, 1107
- template literals, 49–50, 51–53
- template scripts, 794

- <template> tags, 793–794
- templates, HTML, 791–794
- temporal dead zone, 32, 112, 358
- terminate() method, 975, 1001, 1007–1008
- test() function, 29–30, 133, 136, 137–138
- test-driven development (TDD), 1109
- text
 - decoding, 755–758
 - drawing, 681–683
 - encoding, 753–755
 - selecting, 716–718
- text boxes, scripting, 715–726
- text events, 634–640
- text() method, 886, 913
- text nodes
 - creating, 515–516
 - normalizing, 516
 - splitting, 517
- Text type
 - about, 514–515
 - creating text nodes, 515–516
 - normalizing text nodes, 516
 - splitting text nodes, 517
- textAlign property, 681
- textBaseline property, 681
- textInput event, 638–639
- textures, WebGL, 703
- then() method, 407, 410–411, 412, 423
- Thenable interface, 400
- this object
 - about, 365–366
 - closures and, 379–381
 - inside proxies, 332–333
- threads, compared with workers, 970–971
- three.js, 1099
- throttling performance, 674–675
- throw() method, 248–249
- throwing errors, 829–831, 843–844
- TIMEOUT error, 485
- timeout property, 485
- timeouts, 446–448, 879
- timeupdate event, 768
- Timing APIs
 - about, 785–786
 - High Resolution Time API, 786–787
 - Performance Timeline API, 788–791
- title property, 576
- toDataURL() method, 676
- toDate() method, 129
- toDateString() method, 129
- toExponential() method, 142
- toFixed() method, 142
- toggle() method, 549
- toGMTString() method, 129
- toISOString() method, 868–869
- toJSON() method, 868–869
- toLocaleDateString() method, 129
- toLocaleLowerCase() method, 153
- toLocaleString() method, 68, 128, 137, 141, 144, 179–180, 370
- toLocaleTimeString() method, 129
- toLocaleUpperCase() method, 153
- toLowerCase() method, 153
- ToObject() method, 265–266
- tooLong property, 725
- top property, 460
- toPrecision() method, 142–143
- toString() method, 44, 48–49, 51, 68, 71, 83, 84, 128, 137, 141, 144, 179–180, 363, 367–368, 370, 739, 811
- totalBytes property, 766
- toTimeString() method, 129
- touch devices, support for, 633
- touch events, 651–653
- toUpperCase() method, 153
- toUTCString() method, 129
- <tr> element, 527
- transaction() method, 935–936
- transactions, IndexedDB, 935–936
- transferable objects, 988–990
- transform() method, 683, 782–783
- transform streams, 778, 782–783
- transformations, 683–686
- transformToDocument() method, 857–858, 858–859
- transformToFragment() method, 857–858, 858–859
- translate() method, 683
- transparency, of variables, 1038–1039
- transpilation, 1063, 1104–1105
- traps
 - defining, 325–326
 - invariants, 328–329
 - parameters, 326–328
- traversals
 - about, 584–585
 - NodeIterator type, 585–588
 - TreeWalker, 588–590
- tree shaking, 1060–1061
- TreeWalker, 588–590
- trim() method, 151
- trimLeft() method, 151
- trimRight() method, 151
- trusted property, 612
- try/catch statement, 33, 825–829, 831, 840
- 2D, 677–692
- two's complement, 72

type. *See also specific types*
 coercion errors for, 833–835
 determining, 105–106
 type property, 14, 487, 576, 578, 612, 616, 712, 759, 903, 979, 1018
 typed arrays
 about, 190, 196–200
 ArrayBuffers, 191–192
 behaviors, 197–198
 changing, 198–200
 copying, 198–200
 DataViews, 192–195
 emergence of, 191
 history, 190–191
 merging, 198–200
 TypeError property, 160, 828
 typeMismatch property, 726
 typeof operator, 36–37, 106
 types method, 775
 TypeScript, 1104

U

ua-parser-js (website), 480
 Uglify, 1109
 UI events, 619–624
 unary minus operator, 70–72
 unary operators, 68–72
 unary plus operator, 45, 70–72
 undefined property, 160
 Undefined type, 37–38
 underflow, of values, 200
 underscore (`_`), 26
 Underscore.js library, 1097
 unicode property, 134, 1081–1082
 uniforms, 698
 unique property, 942
 unit testing, 1109–1110
 universal modules, 957
 Unkown Runtime Error, 845
 unload event, 622–623
 unregister() method, 1007
 unrolling loops, 1051–1053
 unset() method, 928
 unsetAll() method, 928
 unshift() method, 181–182, 198–200
 unsigned right shift (`>>>`), 76–77
 unwrapping keys, 821
 update() method, 937–938, 1007
 updateAnimations() method, 672
 updateViaCache, managing service workers file
 caching with, 1025

updating service workers, 1024
 upgrading
 custom elements, 807–808
 from GLSL 100 to GLSL 300, 701
 URI-encoding methods, 158–159
 URIError property, 160, 828
 url property, 903, 1018
 URLSearchParams, 452
 User Timing API, 788–789
 user-agent detection
 about, 470
 history of composition of, 470–478
 using for browser analysis, 478–480
 user-agent parsers, 480
 userAgent property, 456

V

valid property, 726
 validating
 parameters of constructors, 346
 parameters of functions, 346
 properties, 345–346
 validation, 725–726, 1061–1062
 value property, 712
 valueMissing property, 726
 valueOf() method, 44, 68, 71, 84, 86, 128, 141, 144, 179–180, 367–368
 values
 copying, 103
 floating-point, 41–42
 functions as, 362–363
 JSON, 862
 passing to shaders, 700
 range of, 42–43
 values() method, 214
 var declaration, 29–31, 109–111
 variable declaration
 about, 109
 block scope declaration using `let`, 111–112
 constant declaration using `const`, 112–113
 function scope declaration using `var`, 109–111
 identifier lookup, 113–114
 variables
 about, 29
 const declaration, 34–35
 declaration styles, 35–36
 let declaration, 31–34
 naming, 1037–1038
 private, 209–211
 strict mode, 1088
 types of transparency, 1038–1039

- var declaration, 29–31
- vendor property, 456, 481
- vendorSub property, 456
- verifying messages with asymmetric keys, 819–820
- versions, JavaScript, 11–12
- vertex shaders, 697
- vibrate() method, 456
- videoHeight property, 766
- videoWidth property, 766
- View property, 612
- viewports, WebGL, 695–696
- Visual Studio Code, 1106
- volume property, 766
- volumechange event, 768
- Vue framework, 1096

W

- wait queue, 751
- waiting property, 768, 1007
- waitUntil() method, 1032–1033
- warn() method, 840
- WeakMap type
 - about, 206
 - basic API, 207–208
 - non-iterable keys, 209
 - utility, 209–211
 - weak keys, 208–209
- WeakSet type
 - about, 217
 - basic API, 217–218
 - non-iterable keys, 219
 - utility, 219–220
 - weak keys, 219
- web browsers. *See also specific web browsers*
 - analysis, using capability detection for, 468–470
 - analysis, using user-agent detection for, 478–480
 - current-device, 480
 - error reporting, 824
 - Google Chrome, 480
 - identifying, 481–482
 - metadata, 482–488
 - Mootools, 480
 - support for Document Object Model (DOM) in, 9–10
 - support for ECMAScript in, 5–7
 - XML DOM support in, 849–852
 - XPath support in, 852–857
 - XSLT support in, 857–859
- web components
 - adding content, 804–805
 - custom elements, 802–808
 - shadow DOM, 795–802
- Web Cryptography API
 - about, 808
 - random number generation, 808–810
 - SubtleCrypto object, 810–821
- Web Sockets
 - events, 916–917
 - limits, 933
 - localStorage object, 932
 - restrictions, 933
 - sessionStorage object, 930–932
 - storage event, 932
- Web Storage, 929–930
- WebAssembly, 1105
- webdriver property, 456
- WebGL
 - about, 190–191, 692–693
 - basics of, 693–704
 - context, 693
 - WebGL1 *versus* WebGL2, 704–705
- WebKit, 475–476
- Webpack, 1103
- websites
 - animations, 1099
 - automation systems, 1107
 - Bowser, 480
 - build tools, 1107
 - compilation/transpilation tools and static type systems, 1104–1105
 - documentation generators, 1110–1112
 - Douglas Crockford's JSLint*, 1061
 - editors, 1106
 - effects, 1099
 - Element Traversal API, 546
 - ESLint, 1061
 - Firebig Lite, 824
 - formatters, 1107–1108
 - frameworks, 1095–1097
 - GitHub repository, 1068
 - Grunt, 1060
 - Gulp, 1060
 - high-performance script tools, 1105
 - jQuery, 544
 - libraries, 1097–1098
 - linters, 1107–1108
 - minifiers, 1109
 - module bundlers, 1103–1104
 - module loaders, 1101–1102, 1102–1103
 - package managers, 1101–1102
 - Platform.js, 480
 - Selectors API, 544
 - task runners, 1107
 - ua-parser-js, 480

- unit testing, 1109–1110
- user-agent parsers, 480
- Web Cryptography API, 808
- wrox.com downloads, 1
- WebStorm, 1106
- wheel events, 625–634
- while statement, 91
- width property, 460
- window object
 - about, 160, 438
 - global scope of, 438–439
 - intervals, 446–448
 - navigating windows, 442–446
 - opening windows, 442–446
 - pixel ratio, 439–440
 - position, 439–440
 - relationships, 439
 - size, 440–441
 - system dialogs, 448–450
 - timeouts, 446–448
 - viewport position, 441–442
- window.CollectGarbage() method, 117
- window.open() method, 443–444, 445–446
- window.opera.collect() method, 117
- windows. *See* window object
- window.URL.createObjectURL() method, 762–763
- wire weight, 1062
- Wise, David
 - The Impact of Applicative Programming on Multiprocessing*, 395
- with statement, 95–96, 109, 1048–1049, 1093
- worker data transfer, 987–993
- worker modules, 965–966
- Worker object, 975
- worker pools, 993–997
- WorkerGlobalScope, 971–973, 972–973
- workers
 - about, 969–970
 - compared with threads, 970–971
 - dedicated, 973–977
 - service, 1003–1033
 - shared, 997–1002

- types of, 971
- WorkerGlobalScope, 971–973
- wrapping keys, 821
- writable streams, 778, 781–782
- write() method, 504–506, 781–782
- WriteableStream, 781
- WriteableStreamDefaultWriter, 781
- writeIn() method, 504–506
- writes, in Atomics API, 747–748
- writing shaders, 697–698
- wrox.com downloads, 1

X

- XHR usage, 872–875
- XHTML (Extensible HyperText Markup Language), 19–20
- XML
 - about, 849
 - DOM support in browsers, 849–852
 - namespaces, 564–568
 - XPath support in browsers, 852–857
 - XSLT support in browsers, 857–859
- XMLHttpRequest object
 - about, 872
 - GET requests, 876–877
 - HTTP headers, 875–876
 - Level 3, 878–880
 - POST requests, 877–878
 - XHR usage, 872–875
- XMLSerializer type, 851–852
- XOR (^) operator, 75
- Xpath support in browsers, 852–857
- XSLT support in browsers, 857–859
- XSLTProcessor type, 857–858

Y

- Yarn, 1102
- yield, interrupting execution with, 238–246
- YUI Doc, 1111